

NATIONAL TOXICOLOGY PROGRAM
Technical Report Series
No. 385



TOXICOLOGY AND CARCINOGENESIS

STUDIES OF

METHYL BROMIDE

(CAS NO. 74-83-9)

IN B6C3F₁ MICE

(INHALATION STUDIES)

U.S. DEPARTMENT OF HEALTH AND HUMAN SERVICES
Public Health Service
National Institutes of Health

FOREWORD

The National Toxicology Program (NTP) is made up of four charter agencies of the U.S. Department of Health and Human Services (DHHS): the National Cancer Institute (NCI), National Institutes of Health; the National Institute of Environmental Health Sciences (NIEHS), National Institutes of Health; the National Center for Toxicological Research (NCTR), Food and Drug Administration; and the National Institute for Occupational Safety and Health (NIOSH), Centers for Disease Control. In July 1981, the Carcinogenesis Bioassay Testing Program, NCI, was transferred to the NIEHS. The NTP coordinates the relevant programs, staff, and resources from these Public Health Service agencies relating to basic and applied research and to biological assay development and validation.

The NTP develops, evaluates, and disseminates scientific information about potentially toxic and hazardous chemicals. This knowledge is used for protecting the health of the American people and for the primary prevention of disease.

The studies described in this Technical Report were performed under the direction of the NIEHS and were conducted in compliance with NTP laboratory health and safety requirements and must meet or exceed all applicable federal, state, and local health and safety regulations. Animal care and use were in accordance with the Public Health Service Policy on Humane Care and Use of Animals. The prechronic and chronic studies were conducted in compliance with Food and Drug Administration Good Laboratory Practice Regulations and all aspects of the chronic studies were subjected to retrospective quality assurance audits before being presented for public review.

These studies are designed and conducted to characterize and evaluate the toxicologic potential, including carcinogenic activity, of selected chemicals in laboratory animals (usually two species, rats and mice). Chemicals selected for NTP toxicology and carcinogenesis studies are chosen primarily on the bases of human exposure, level of production, and chemical structure. Selection per se is not an indicator of a chemical's carcinogenic potential.

These NTP Technical Reports are available for sale from the National Technical Information Service, U.S. Department of Commerce, 5285 Port Royal Road, Springfield, VA 22161 (703-487-4650). Single copies of this Technical Report are available without charge while supplies last from the NTP Central Data Management, NIEHS, P.O. Box 12233, MD A0-01, Research Triangle Park, NC 27709 (919-541-3991).

NTP TECHNICAL REPORT
ON THE
TOXICOLOGY AND CARCINOGENESIS
STUDIES OF METHYL BROMIDE
(CAS NO. 74-83-9)
IN B6C3F₁ MICE
(INHALATION STUDIES)

NATIONAL TOXICOLOGY PROGRAM
P.O. Box 12233
Research Triangle Park, NC 27709

March 1992

NTP TR 385

NIH Publication No. 92-2840

U.S. DEPARTMENT OF HEALTH AND HUMAN SERVICES
Public Health Service
National Institutes of Health

CONTRIBUTORS

National Toxicology Program

Evaluated and interpreted results and reported findings

C.J. Alden, Ph.D.
G.A. Boorman, D.V.M., Ph.D.
D.W. Bristol, Ph.D.
S.L. Eustis, D.V.M., Ph.D.
T.J. Goehl, Ph.D.
R.A. Griesemer, D.V.M., Ph.D.
J.K. Haseman, Ph.D.
M.M. McDonald, D.V.M., Ph.D.
G.N. Rao, D.V.M., Ph.D.
K.L. Witt, M.S., Oak Ridge Associated Universities
R.S.H. Yang, Ph.D.

Brookhaven National Laboratory

Conducted studies, evaluated pathology findings

R.T. Drew, Ph.D., Co-Principal Investigator
S.B. Haber, Ph.D., Co-Principal Investigator,
Study Director
R.B. Aronson, Ph.D.
E.P. Cronkite, M.D.
D.C. Graham, M.D., Ph.D.
Duke University (Subcontractor to BNL)
L.V. Hankes, Ph.D.
D.D. Joel, D.V.M., Ph.D.
G. Senum, Ph.D.

Integrated Laboratory Systems

Prepared quality assurance audits

J.C. Bhandari, D.V.M., Ph.D., Principal Investigator

Experimental Pathology Laboratories

Provided pathology quality assurance

J.F. Hardisty, D.V.M., Principal Investigator

NTP Pathology Working Group

*Evaluated slides, prepared pathology report for mice
(6 January 1989)*

J.C. Seely, D.V.M. Chair
PATHCO
J. Cullen, V.M.D., Ph.D.
North Carolina State University
M.R. Elwell, D.V.M., Ph.D.
National Toxicology Program
S.L. Eustis, D.V.M., Ph.D.
National Toxicology Program
J.R. Leininger, D.V.M., Ph.D.
National Toxicology Program
M.M. McDonald, D.V.M., Ph.D.
National Toxicology Program
G. Riley, M.V.Sc., Ph.D.
Experimental Pathology Laboratories, Inc.

Biotechnical Services, Inc.

Prepared Technical Report

L.G. Cockerham, Ph.D. Principal Investigator
G.F. Corley, D.V.M.
P.R. Dennis, M.C.M.
B.B. Randolph, M.B.A.

CONTENTS

ABSTRACT		5
EXPLANATION OF LEVELS OF EVIDENCE OF CARCINOGENIC ACTIVITY		8
PEER REVIEW PANEL		9
SUMMARY OF PEER REVIEW COMMENTS		10
INTRODUCTION		11
MATERIALS AND METHODS		19
RESULTS		29
DISCUSSION AND CONCLUSIONS.		45
REFERENCES.		49
APPENDIX A	Summary of Lesions in Male Mice in the 2-Year Inhalation Study of Methyl Bromide	55
APPENDIX B	Summary of Lesions in Female Mice in the 2-Year Inhalation Study of Methyl Bromide	93
APPENDIX C	Organ Weights and Organ-Weight-to-Body-Weight Ratios	133
APPENDIX D	Neurobehavioral Analyses	145
APPENDIX E	Hematology and Pseudocholinesterase Results	159
APPENDIX F	Genetic Toxicology	167
APPENDIX G	Chemical Characterization, Analysis, and Generation of Chamber Concentrations	175
APPENDIX H	Ingredients, Nutrient Composition, and Contaminant Levels in NIH-07 Rat and Mouse Ration	185
APPENDIX I	Sentinel Animal Program	191
APPENDIX J	Special 6-Week Target Organ Toxicity Studies	195

ABSTRACT

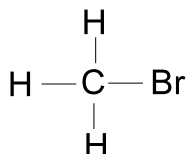

METHYL BROMIDE

CAS No. 74-83-9

Chemical Formula: CH_3Br Molecular Weight: 94.95
 $1 \text{ mg/m}^3 = 0.257 \text{ ppm}$
 $1 \text{ ppm} = 3.891 \text{ mg/m}^3$

Synonym: Bromomethane

Methyl bromide is widely used as a fumigant and pesticide. Toxicology and carcinogenesis studies were conducted by exposing groups of male and female B6C3F₁ mice to methyl bromide (99.8% pure) by inhalation 6 hours per day, 5 days per week, for 14 days, 6 weeks, 13 weeks, or 2 years. Six-week and 13-week inhalation toxicity studies in F344/N rats were conducted concurrently with the mouse studies. Hematology parameters were measured during the 6-week, 13-week, and 2-year studies. Quantitative neurobehavioral testing was performed during the 14-day, 13-week and 2-year studies. Genetic toxicology studies were conducted for gene mutation induction in *Salmonella typhimurium* and for induction of sister chromatid exchanges in mouse bone marrow cells and of micronuclei from peripheral blood erythrocytes.

14-Day Studies: Groups of five B6C3F₁ mice of each sex were exposed to 0, 12, 25, 50, 100, or 200 ppm methyl bromide by inhalation 6 hours per day, 5 days per week for 2 weeks. Only four female mice and one male mouse survived 10 exposures at 200 ppm. No deaths occurred at the lower doses. Neurobehavioral effects including trembling and paralysis were noted in all groups, but were most

pronounced in the three highest dose groups. Red urine was noted in the mice exposed to 200 ppm.

13-Week Studies: Groups of 10 mice of each sex were exposed to 0, 10, 20, 40, 80, or 120 ppm methyl bromide by inhalation 6 hours per day, 5 days per week for 13 weeks. Additional groups of eight to 17 mice were concurrently exposed for neurobehavioral and genetic toxicology studies. The final mean body weight of males exposed to 120 ppm was significantly (12%) lower than that of the controls. Four of 24 males exposed to 120 ppm died during the study.

Groups of 10 rats of each sex were exposed to 0, 30, 60, or 120 ppm methyl bromide by inhalation 6 hours per day, 5 days per week for 13 weeks. Additional groups of eight rats were concurrently exposed for neurobehavioral studies. Final mean body weights of rats exposed to 120 ppm were 12% lower than those of the controls for males and 13% lower for females. No rats died as a result of methyl bromide exposure during the studies.

Special 6-Week Target Organ Toxicity Studies: Neither the 14-day nor the 13-week studies provided

strong evidence for specific organ toxicity. Six-week studies were therefore conducted to identify target organs for the 2-year studies. Groups of 20 rats and mice of each sex were exposed to methyl bromide by inhalation for 6 hours per day, 5 days per week for 6 weeks at a dose of 160 ppm. Mortality rates exceeded 50% in the male mice after eight exposures, in female mice after six exposures, and in male rats after 14 exposures. Only the female rat group survived 30 exposures with less than 50% mortality. The study identified the brain, kidney, nasal cavity, heart, adrenal gland, liver, and testis as the primary organs to examine for toxicity in the 2-year methyl bromide inhalation studies.

2-Year Studies: Groups of 70 B6C3F₁ mice of each sex were exposed to methyl bromide by inhalation at 0, 10, 33, or 100 ppm for 6 hours per day, 5 days per week for up to 103 weeks. Additional groups of 16 mice were included for neurobehavioral evaluations throughout the 2-year studies. By 20 weeks (139 days), 27 males and 7 females exposed to 100 ppm had died and methyl bromide exposure was discontinued for the remaining mice in this dose group. Ten female mice from the 100 ppm group pre-designated for the 15-month interim evaluation were killed on schedule and all other high-dose animals were allowed to live to term (24 months) for evaluation of chronic toxicity and carcinogenicity. Clinical signs indicative of neurotoxicity, including tremors, abnormal posture, tachypnea, and hind leg paralysis, persisted in these high-dose mice until the end of the studies.

Final mean body weights of surviving 100 ppm males and females were markedly lower (33% and 31%) than those of the controls. Neurobehavioral changes occurred in male and female mice initially exposed to 100 ppm methyl bromide, with more pronounced changes observed in males. In general, these animals were less active and manifested a heightened sensitivity in the startle response than mice in other dose groups.

Exposure to methyl bromide was not carcinogenic under the conditions of these studies. However, there was an increase in the incidence of several nonneoplastic lesions in the brain, heart, bone (sternum), and nose. Degenerative changes in the cerebellum and cerebrum occurred in males and females exposed to 100 ppm. Myocardial degeneration and cardiomyopathy were observed in the hearts of mice exposed to 100 ppm. An increased incidence of sternal dysplasia was seen in treated animals, particularly in those exposed to 100 ppm. An increased incidence of olfactory epithelial necrosis and metaplasia within the nasal cavity was seen in the mice exposed to 100 ppm, particularly males.

Genetic Toxicology: Methyl bromide was positive for induction of gene mutations in *Salmonella typhimurium* strain TA100, with and without exogenous metabolic activation; negative results were obtained with TA98 in this assay. *In vivo*, methyl bromide induced sister chromatid exchanges in bone marrow cells and micronuclei in peripheral erythrocytes of female mice exposed by inhalation for 14 days. No significant increase in either sister chromatid exchanges or micronuclei was observed in male or female mice exposed to methyl bromide by inhalation for 4, 8, or 12 weeks.

Conclusions: Under the conditions of these 2-year inhalation studies, methyl bromide caused degenerative changes in the cerebellum and cerebrum, myocardial degeneration and cardiomyopathy, sternal dysplasia, and olfactory epithelial necrosis and metaplasia. Toxic effects persisted although exposure to methyl bromide in the 100 ppm group terminated after 20 weeks. There was *no evidence of carcinogenic activity** of methyl bromide in male or female B6C3F₁ mice exposed to 10, 33, or 100 ppm.

*Explanation of Levels of Evidence of Carcinogenic Activity is on page 8. A summary of peer review comments and the public discussion on this Technical Report appears on page 10.

Summary of the 2-Year Carcinogenesis and Genetic Toxicology Studies of Methyl Bromide

Variable	Male B6C3F ₁ Mice	Female B6C3F ₁ Mice
Doses	0, 10, 33, or 100 ^a ppm by inhalation 6 hours per day, 5 days per week	0, 10, 33, or 100 ^a ppm by inhalation 6 hours per day, 5 days per week
Body weights	High-dose group lower than controls	High-dose group lower than controls
2-Year survival rates	40/50, 37/50, 40/50, 16/70 ^a	36/50, 41/50, 45/50, 40/60 ^a
Nonneoplastic effects	Brain: cerebellar degeneration (0/50, 0/50, 0/50, 31/70); cerebral degeneration (0/50, 0/50, 0/50, 11/70) Heart: degeneration (0/50, 0/50, 0/50, 32/70); chronic cardiomyopathy (4/50, 7/50, 10/50, 24/70) Bone: sternal dysplasia (0/50, 0/50, 3/50, 14/70) Nose: olfactory epithelial metaplasia (0/50, 0/50, 1/50, 2/69); olfactory epithelial necrosis (0/50, 0/50, 0/50, 6/69)	Brain: cerebellar degeneration (0/50, 0/50, 0/50, 11/60); cerebral degeneration (0/50, 0/50, 0/50, 2/60) Heart: degeneration (1/50, 0/50, 0/50, 7/59); chronic cardiomyopathy (2/50, 4/50, 2/50, 34/59) Bone: sternal dysplasia (0/50, 2/50, 2/50, 9/60) Nose: olfactory epithelial metaplasia (0/50, 0/50, 0/50, 5/60)
Neoplastic effects	None	None
Uncertain findings	None	None
Level of evidence of carcinogenic activity	No evidence	No evidence
Genetic toxicology		
<i>Salmonella typhimurium</i> gene mutations:	Positive with and without metabolic activation in strain TA100; Negative with and without metabolic activation in strain TA98	
Sister chromatid exchanges Mouse bone marrow <i>in vivo</i> :	Positive in 14-day studies; Negative in 12-week studies	
Micronuclei Mouse peripheral erythrocytes <i>in vivo</i> :	Positive in 14-day studies; Negative in 12-week studies	

^a Because of high early mortality, exposure of males and females to 100 ppm was discontinued on day 139 of the studies; the 6-month interim evaluation was not carried out in the 100 ppm male and female mice, and the 15-month interim evaluation was not carried out in the 100 ppm male mice. The extra animals were included in the 100 ppm groups at the end of the studies to provide a larger pool of animals for chronic toxicity/carcinogenicity evaluation.

EXPLANATION OF LEVELS OF EVIDENCE OF CARCINOGENIC ACTIVITY

The National Toxicology Program describes the results of individual experiments on a chemical agent and notes the strength of the evidence for conclusions regarding each study. Negative results, in which the study animals do not have a greater incidence of neoplasia than control animals, do not necessarily mean that a chemical is not a carcinogen, inasmuch as the experiments are conducted under a limited set of conditions. Positive results demonstrate that a chemical is carcinogenic for laboratory animals under the conditions of the study and indicate that exposure to the chemical has the potential for hazard to humans. Other organizations, such as the International Agency for Research on Cancer, assign a strength of evidence for conclusions based on an examination of all available evidence including: animal studies such as those conducted by the NTP, epidemiologic studies, and estimates of exposure. Thus, the actual determination of risk to humans from chemicals found to be carcinogenic in laboratory animals requires a wider analysis that extends beyond the purview of these studies.

Five categories of evidence of carcinogenic activity are used in the Technical Report series to summarize the strength of the evidence observed in each experiment: two categories for positive results (**clear evidence** and **some evidence**); one category for uncertain findings (**equivocal evidence**); one category for no observable effects (**no evidence**); and one category for experiments that because of major flaws cannot be evaluated (**inadequate study**). These categories of interpretative conclusions were first adopted in June 1983 and then revised in March 1986 for use in the Technical Reports series to incorporate more specifically the concept of actual weight of evidence of carcinogenic activity. For each separate experiment (male rats, female rats, male mice, female mice), one of the following quintet is selected to describe the findings. These categories refer to the strength of the experimental evidence and not to either potency or mechanism.

- **Clear evidence of carcinogenic activity** is demonstrated by studies that are interpreted as showing a dose-related (i) increase of malignant neoplasms, (ii) increase of a combination of malignant and benign neoplasms, or (iii) marked increase of benign neoplasms if there is an indication from this or other studies of the ability of such tumors to progress to malignancy.
- **Some evidence of carcinogenic activity** is demonstrated by studies that are interpreted as showing a chemical-related increased incidence of neoplasms (malignant, benign, or combined) in which the strength of the response is less than that required for clear evidence.
- **Equivocal evidence of carcinogenic activity** describes studies that are interpreted as showing a marginal increase of neoplasms that may be chemical related.
- **No evidence of carcinogenic activity** is demonstrated by studies that are interpreted as showing no chemical-related increases in malignant or benign neoplasms.
- **Inadequate study of carcinogenic activity** is demonstrated by studies that because of major qualitative or quantitative limitations cannot be interpreted as valid for showing either the presence or absence of carcinogenic activity.

When a conclusion statement for a particular experiment is selected, consideration must be given to key factors that would extend the actual boundary of an individual category of evidence. This should allow for incorporation of scientific experience and current understanding of long-term carcinogenesis studies in laboratory animals, especially for those evaluations that may be on the borderline between two adjacent levels. These considerations should include:

- adequacy of the experimental design and conduct;
- occurrence of common versus uncommon neoplasia;
- progression (or lack thereof) from benign to malignant neoplasia as well as from preneoplastic to neoplastic lesions;
- some benign neoplasms have the capacity to regress but others (of the same morphologic type) progress. At present, it is impossible to identify the difference. Therefore, where progression is known to be a possibility, the most prudent course is to assume that benign neoplasms of those types have the potential to become malignant;
- combining benign and malignant tumor incidences known or thought to represent stages of progression in the same organ or tissue;
- latency in tumor induction;
- multiplicity in site-specific neoplasia;
- metastases;
- supporting information from proliferative lesions (hyperplasia) in the same site of neoplasia or in other experiments (same lesion in another sex or species);
- presence or absence of dose relationships;
- statistical significance of the observed tumor increase;
- concurrent control tumor incidence as well as the historical control rate and variability for a specific neoplasm;
- survival-adjusted analyses and false positive or false negative concerns;
- structure-activity correlations; and
- in some cases, genetic toxicology.

PEER REVIEW PANEL

The members of the Peer Review Panel who evaluated the draft Technical Report on methyl bromide on November 19, 1990, are listed below. Panel members serve as independent scientists, not as representatives of any institution, company, or governmental agency. In this capacity, Panel members have five major responsibilities:

- to ascertain that all relevant literature data have been adequately cited and interpreted,
- to determine if the design and conditions of the NTP studies were appropriate,
- to ensure that the Technical Report presents the experimental results and conclusions fully and clearly,
- to judge the significance of the experimental results by scientific criteria, and
- to assess the evaluation of the evidence of carcinogenic activity and other observed toxic responses.

National Toxicology Program Board of Scientific Counselors Technical Reports Review Subcommittee

Robert A. Scala, Ph.D., Chair
Medicine and Environmental Health Department
Research and Environmental Health Division
Exxon Corp.
East Millstone, NJ

Daniel S. Longnecker, M.D., Principal Reviewer
Department of Pathology
Dartmouth Medical School
Hanover, NH

Jay I. Goodman, Ph.D.
Department of Pharmacology and Toxicology
Michigan State University
East Lansing, MI

Ellen K. Silbergeld, Ph.D.
University of Maryland Medical School
Baltimore, MD

Ad Hoc Subcommittee Panel of Experts

John Ashby, Ph.D., Principal Reviewer
Central Toxicology Laboratory
Imperial Chemical Industries, PLC
Alderley Park, England

David W. Hayden, D.V.M., Ph.D.
Department of Veterinary Pathobiology
College of Veterinary Medicine
University of Minnesota
St. Paul, MN

Gary P. Carlson, Ph.D.
Department of Pharmacology and Toxicology
Purdue University
West Lafayette, IN

Curtis D. Klaassen, Ph.D.
Department of Pharmacology and Toxicology
University of Kansas Medical Center
Kansas City, KS

Harold Davis, D.V.M., Ph.D.
School of Aerospace Medicine
Brooks Air Force Base, TX

Barbara McKnight, Ph.D.
Department of Biostatistics
University of Washington
Seattle, WA

Robert H. Garman, D.V.M.
Consultants in Veterinary Pathology
Murrysville, PA

Lauren Zeise, Ph.D., Principal Reviewer
California Department of Health Services/RCHAS
Berkeley, CA

Lois Swirsky Gold, Ph.D.
Lawrence Berkeley Laboratory
University of California
Berkeley, CA

SUMMARY OF PEER REVIEW COMMENTS

On November 19, 1990, the draft Technical Report on the toxicology and carcinogenesis studies of methyl bromide received public review by the National Toxicology Program Board of Scientific Counselors' Technical Reports Review Subcommittee and associated Panel of Experts. The review meeting was held at the National Institute of Environmental Health Sciences, Research Triangle Park, North Carolina.

Dr. R.S.H. Yang, NTP Staff Scientist, and Dr. S.L. Eustis, NIEHS, were present. Dr. Eustis introduced the toxicology and carcinogenesis studies of methyl bromide by discussing the uses and rationale for study, describing the experimental design, reporting on survival and body weight effects, and commenting on compound-related nonneoplastic lesions in male and female mice. The proposed conclusions were *no evidence of carcinogenic activity* in male or female B6C3F₁ mice.

Dr. Ashby, a principal reviewer, agreed with the proposed conclusions. He said that because methyl bromide is a methylating agent and is clearly genotoxic *in vitro* and *in vivo*, it was surprising that the chemical had no neoplastic effects.

Dr. Zeise, the second principal reviewer, agreed with the proposed conclusions. She was pleased with the dose level selection, noting that even though the maximum tolerated dose apparently was exceeded in male mice, the other two dose groups were adequate for evaluation.

Dr. Longnecker, the third principal reviewer, agreed with the proposed conclusions. However, he inquired why more import was not given to the increased incidence of animals with malignant

tumors, which was significantly greater in low-dose male mice ($P=0.01$) than in controls. Dr. Eustis replied that the increase in malignant tumors was primarily due to an increase in alveolar/bronchiolar carcinomas, which was balanced by a decreased incidence in adenomas. Since the adenomas and carcinomas are a morphologic continuum and, further, since the increased incidence of malignant neoplasms was not observed in the mid- or high-dose groups, the NTP staff did not consider this to be an effect of methyl bromide exposure.

Dr. Yang reported that a chronic study in Wistar rats by Dutch workers had given negative results. He said more details on the rat study would be included in the report. Dr. Silbergeld was surprised that the central nervous system pathology was noted only in the high-dose group while other data suggest that there is much more of a dose-related trend in the overt neurotoxicity of the chemical. She advised caution in interpreting the neurotoxicity results, both behavioral and pathologic, as there are pitfalls in some of the tests used to measure neurotoxicity. Some of the panelists suggested adding incidence rates for significant nonneoplastic lesions to the summary table in the Abstract. Dr. Scala commented that the sense of the Panel was that they wanted the Abstract and the text to reflect a report on an important neurotoxicant, and the staff indicated that this perspective would be given.

Dr. Ashby moved that the Technical Report on methyl bromide be accepted with the revisions discussed and the conclusions as written for male and female mice, *no evidence of carcinogenic activity*. Dr. Zeise seconded the motion, which was accepted unanimously with twelve votes.

INTRODUCTION

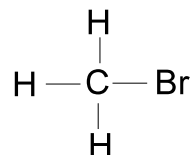

METHYL BROMIDE

CAS No. 74-83-9

Chemical Formula: CH_3Br Molecular Weight: 94.95

$1 \text{ mg/m}^3 = 0.257 \text{ ppm}$

$1 \text{ ppm} = 3.891 \text{ mg/m}^3$

Synonym: Bromomethane

PHYSICAL AND CHEMICAL PROPERTIES

Methyl bromide is a colorless gas at room temperature. It is three times more dense than air and is extremely penetrating. Methyl bromide has little odor at potentially toxic concentrations, and serious exposure can occur without warning. In addition, some of the more severe effects are delayed. Even

though a warning agent such as chloropicrin is generally added, the difference in vapor pressure between methyl bromide (1,420 mm mercury at 20°C) and chloropicrin (18.3 mm mercury at 20°C) makes the effectiveness of this warning agent questionable (Alexeeff and Kilgore, 1983). A summary of the physical and chemical properties of methyl bromide is given in Table 1.

TABLE 1
Some Chemical and Physical Properties of Methyl Bromide^a

Melting point	-93.66°C
Boiling point	3.56°C
Specific gravity	1.732 (0/0°C)
Vapor pressure	1,420 mm mercury at 20°C
Solubility	0.09 g/100 mL water at 20°C, soluble in most common organic solvents

^a Merck Index (1983)

USE AND PRODUCTION

Methyl bromide is widely used as an insecticidal fumigant in food supplies, warehouses, barges, buildings, furniture, and in quarantine situations (Mailman, 1988). Its popularity as a fumigant is largely attributable to its high toxicity to many pests, the variety of settings in which it can be applied, its ability to penetrate the fumigated substances, and its rapid dissipation following application. Methyl bromide is also used in fire extinguishers and refrigerant systems, and in the chemical industry as a methylating agent and an extraction solvent (Alexeeff and Kilgore, 1983; *Merck Index*, 1983).

The 1981 production of methyl bromide in the United States was approximately 46.2 million pounds. An estimated 70% of the chemical produced went into pesticide formulations (USEPA, 1984). More recent production information is not available to the public.

HUMAN EXPOSURE AND TOXICITY

The primary route for human exposure to methyl bromide is inhalation. Several reports (Van Den Oever *et al.*, 1982; Alexeeff and Kilgore, 1983; NIOSH, 1984; Maddy *et al.*, 1990) summarize studies related to occupational exposure to methyl bromide. At least 115 known fatalities and 843 known systemic, skin, eye, and other injuries have resulted from methyl bromide exposure (Alexeeff and Kilgore, 1983). In California, the most frequent cause of death from methyl bromide exposure in recent years has been unauthorized entry into structures under fumigation. Even though these structures were locked, covered with gas resistant tarpaulins, and had posted warning signs, burglars, transients, or intoxicated persons ignored the signs, broke into the structures, and succumbed to chemical toxicity (Maddy *et al.*, 1990). The most frequently reported lesions included pulmonary edema, congestion, and hemorrhage (Alexeeff and Kilgore, 1983). From a survey conducted from 1981 to 1983, NIOSH has estimated that 105,000 workers in the United States are potentially exposed to methyl bromide (NIOSH, 1990). In 1980, the American Conference of Governmental Industrial Hygienists adopted a threshold limit value of 5 ppm and a short-term exposure limit of 15 ppm in workplace air (ACGIH, 1980).

Toxicity resulting from dermal exposure of methyl bromide has also been demonstrated in humans, and standard protective clothing did little to prevent such exposure in fumigation operations (Zwaveling *et al.*, 1987; Hezemans-Boer *et al.*, 1988). In one instance, six individuals were reported to have been exposed while fumigating a thirteenth-century castle. All wore overalls over their daily clothing and used airway protection with face masks and breathing air. Exposure time was approximately 40 minutes. Within 8 hours of exposure, all developed sharply demarcated erythema with multiple vesicles and large bullae, principally in the areas of the axillae, groin, vulva, penis, scrotum, perineum, and umbilicus.

METABOLISM AND PHARMACOKINETICS

In rats, methyl bromide is readily absorbed from the respiratory tract, widely distributed in tissues, and rapidly metabolized. Bond *et al.* (1985) and Medinsky *et al.* (1985) reported that following a single 6-hour inhalation exposure to 337 nmol of ¹⁴C-methyl bromide per liter air, the highest concentrations of radioactivity were present in the lung, adrenal gland, kidney, liver, and nasal turbinates. Methyl bromide metabolites accounted for over 90% of the radioactivity in all tissues examined. Jaskot *et al.* (1988) studied the distribution and toxicity of inhaled methyl bromide in male CD rats in two different types of experiments. In one, they gave a 3-minute nose-only exposure of ¹⁴C-methyl bromide at a concentration of 55 ppm (≈ 215 mg/m³) to the rats and followed the elimination of radioactivity for up to 32 hours. In the other experiment, rats were given whole-body exposure to 30 ppm methyl bromide for 5 or 30 consecutive days, and enzymes and other biochemical indices were measured. Liver, kidney, and lung contained 14%, 9%, and 6% of the radiolabel. Altered levels (i.e., increases or decreases) of a number of enzymes in the lung and liver, as well as decreases in blood urea nitrogen, cholesterol, cholinesterase, and uric acid were observed; however, no toxicologic significance was attached to these changes. Jaskot *et al.* (1988) concluded that inhaled methyl bromide is rapidly distributed to all tissues.

Bond *et al.* (1985) and Medinsky *et al.* (1985) found that 47% of the carbon label in ¹⁴C-methyl bromide was eliminated in expired air as ¹⁴CO₂ and that

exhalation was the primary route of elimination. Kombrust and Bus (1982) reported similar findings for the elimination of the carbon labels following a single-inhalation exposure of rats to carbon-labeled methyl chloride. Jaskot *et al.* (1988) also identified the major clearance pathway for methyl bromide as exhaled CO₂, which accounted for 43% of the total inhaled dose 32 hours after exposure. In contrast, urinary and fecal excretion accounted for only 21% and 2% respectively. They concluded that while the metabolism of methyl bromide is efficient, a small portion was incorporated into carbon metabolic pools and cleared more slowly.

Gargas and Andersen (1982) studied the kinetics of uptake and metabolism of four brominated hydrocarbons, including methyl bromide, in F344/N rats by the "gas uptake technique" and by the direct measurement of bromide ion liberated as a result of metabolism. The initial concentrations from a single injection of methyl bromide into the inhalation chamber ranged from 100 to 3,000 ppm, and the study duration varied from 2 to 6 hours. Gargas and Andersen (1982) reported that, in the concentration range studied, the *in vivo* metabolism rate of inhaled methyl bromide was first order, with rate constants of 0.55/kg per hour for gas uptake and 0.32/kg per hour for bromide production. Because methyl bromide is acutely toxic, these investigators speculated that the concentrations used might be below the inhalation K_m of methyl bromide, thus accounting for the linear kinetic behavior observed.

SHORT-TERM TOXICITY

Short-term toxicity tests in various species have shown that methyl bromide is highly toxic to mammals. In one study, rats, guinea pigs, rabbits, and monkeys received 239 exposures by inhalation for almost 11 months (Irish *et al.*, 1940). At

0.85 mg/L (approximately 220 ppm), rats, guinea pigs, and rabbits died after one to four exposures. Although significant microscopic lesions were not found in rats, marked pulmonary damage, including congestion, edema, and leukocytic infiltration with frequent hemorrhage into the alveoli, was observed in guinea pigs. Mortality due to toxicity also occurred at 0.42 mg/L (approximately 100 ppm). Guinea pigs were more resistant than rats at this concentration. Rabbits in this dose group usually exhibited paralysis, and one monkey developed convulsions after receiving 11 exposures over 14 days. In all species, the primary site of injury was the lung. Rats and guinea pigs exposed at 0.25 mg/L (approximately 66 ppm) for up to 6 months had no adverse effects. Rabbits and monkeys, however, developed paralysis after fewer than 68 exposures. The paralysis was particularly severe in rabbits with pulmonary lesions. At 0.13 mg/L (approximately 33 ppm), rabbits still showed pulmonary damage; the monkeys appeared normal. All animals survived without adverse effects at 0.065 mg/L (approximately 17 ppm). Values for the lowest published lethal concentrations (LC₁₀) of methyl bromide for several species are summarized in Table 2.

Hurt *et al.* (1987) investigated the histologic changes induced in selected tissues from F344/N rats following acute inhalation exposure to 0, 90, 175, 250, or 325 ppm methyl bromide 6 hours per day for 5 days. The principal clinical findings, confined to the 250 and 325 ppm groups, were diarrhea, hemoglobinuria, and, in a few instances, gait disturbances and convulsions. A dose-dependent vacuolar degeneration of the zona fasciculata of the adrenal glands, cerebellar granule cell degeneration, and nasal olfactory sensory cell degeneration were seen in treated rats in all but the lowest dose group.

TABLE 2
LC₁₀ Values for Methyl Bromide in Inhalation Studies^a

Species	LC ₁₀ ^b
Human	60,000 ppm (2 h)
Human (child)	1,000 mg/m ³ (2 h) (approximately 257 ppm)
Rat	3,120 ppm (15 min)
Rabbit	2,000 mg/m ³ (11 h) (approximately 514 ppm)
Guinea pig	300 ppm (9 h)

^a NIOSH (1980)

^b Lowest published lethal concentration

Cerebral cortical degeneration and minor alteration in testicular histology were seen in only the 325 ppm group. In the two highest dose groups, hepatocellular degeneration was also seen. Further studies from the same laboratory (Hurtt *et al.*, 1988) demonstrated that the olfactory mucosa is highly sensitive to the toxic effects of methyl bromide and that olfactory epithelial cell proliferation, and possible regeneration, begins and occurs rapidly even with continued exposure. Cell replication was most prominent in the layer of basal cells adjacent to the basal lamina, suggesting that the progenitors of both sustentacular cells and neurons reside in this location. Hurtt *et al.* (1988) also observed that functional recovery occurs prior to complete morphological reorganization, indicating the shortcoming of olfactory morphology as an index of functional integrity.

Because methyl chloride, a close analog of methyl bromide, is a known reproductive toxicant in male F344/N rats, Hurtt and Working (1988) evaluated spermatogenesis and sperm quality in the rat following acute exposure (200 ppm 6 hours per day for 5 days) to methyl bromide. Their findings indicated that, although methyl bromide causes a transient decrease in plasma testosterone and testicular nonprotein sulfhydryl concentrations during acute exposure, it has no lasting effect on sperm quality or spermatogenesis in F344/N rats.

The neurobehavioral or neurobiochemical effects of methyl bromide have been reported by several investigators. Anger *et al.* (1981) studied neurobehavioral effects of methyl bromide inhalation exposure on Sprague-Dawley rats and New Zealand white rabbits. Rabbits exposed to 65 ppm methyl bromide for 4 weeks (total exposure time of 100 hours) had significantly reduced eye blink responses and nerve conduction velocity. Rats tolerated identical exposure conditions without any effect. Extended inhalation exposure at 55 ppm for 36 weeks (total exposure time of 1,080 hours) also had no effect on nerve conduction velocity, open-field activity, or coordination in rats. A later report from the same laboratory (Russo *et al.*, 1984) indicated that rabbits, a species sensitive to methyl bromide, did not show any untoward neurobehavior responses after inhalation exposure to 27 ppm methyl bromide for 7.5 hours per day, 4 days per week for 8 months (total exposure time of 900 hours). These authors suggested that rabbits may tolerate long-term, low-level exposure to methyl

bromide. Further, they speculated that recovery from a nonfatal but seriously debilitating exposure is possible. In a separate study with a recovery period following dosing, rabbits developed severe neuromuscular losses and had impaired blink reflexes after short-term exposure to methyl bromide at 65 ppm; 6 to 8 weeks after cessation of exposure, they had only partially recovered. In other methyl bromide exposure studies, the induction of conditioned taste aversion in Sprague-Dawley rats (Miyagawa, 1982) and changes in monoamine or amino acid contents in rat brain (Honma *et al.*, 1982, 1983) were observed.

Danse *et al.* (1984) gave methyl bromide dissolved in peanut oil by gavage at doses of 0, 0.4, 2, 10, or 50 mg/kg, 5 times per week for 13 weeks to groups of 10 male and 10 female Wistar rats. According to these investigators, the most striking and unusual finding was the development of forestomach squamous cell papillomas (two males) and carcinomas (seven males, six females) in rats given 50 mg/kg, although other scientists disagreed regarding the malignant nature of these lesions (*Pestic. Toxicol. Chem. News*, 1984; Boorman *et al.*, 1986). Danse *et al.* (1984) also found diffuse hyperplasia and hyperkeratosis of the forestomach in male and female rats receiving the two highest doses. Methyl bromide exposure also affected body weight gain (depressed in males receiving 50 mg/kg), feed consumption (reduced in males and females receiving 50 mg/kg), and hematologic values (slight anemia in males receiving 50 mg/kg and a slight increase in leukocytes in males and females receiving 50 mg/kg). Because of the commercial importance of methyl bromide, another study conducted by Boorman *et al.* (1986) was initiated to distinguish between cases of marked hyperplasia and neoplasia and to investigate regression of lesions. The design of the Boorman *et al.* (1986) study was based on that reported by Danse *et al.* (1984), but dose groups with a recovery period were included to study the progression or regression of lesions. Boorman *et al.* (1986) administered methyl bromide in peanut oil by gavage to groups of male Wistar rats for 13 weeks, with a 12-week recovery period, for a total of 25 weeks; necropsies were performed 13, 17, 21, and 25 weeks after initiation of the study. At week 13, inflammation, acanthosis, fibrosis, and a high incidence of pseudoepitheliomatous hyperplasia in the forestomach were observed microscopically in dosed animals. At week 25, all of the rats receiving methyl bromide continuously had the more

severe hyperplastic lesions of the forestomach. Evidence of malignancy was seen in 1 of 15 rats, and the lesion was considered to be an early carcinoma. In the dose group with recovery, even though methyl bromide dosing was stopped at week 13, the results at the end of the 25 week study revealed adhesions between the forestomach and the liver and spleen, as well as fibrosis and mild acanthosis. However, the proliferative lesions in these animals had regressed, and Boorman *et al.* indicated that these lesions should not be considered neoplasms.

GENETIC TOXICOLOGY

Methyl bromide was positive with and without S9 metabolic activation in tests for the induction of gene mutations in bacteria (Simmon *et al.*, 1977; Djalali-Behzad *et al.*, 1981; Moriya *et al.*, 1983; Kramers *et al.*, 1985) and plants (Ehrenberg *et al.*, 1974). Exposure by inhalation of methyl bromide gas at concentrations of 150 to 487 mg/m³ (approximately 39 to 125 ppm), 6 hours per day for 5 days resulted in a significant increase in sex-linked recessive lethal mutations in the germ cells of male *Drosophila melanogaster* (Kramers *et al.*, 1985); single exposures to methyl bromide gas at concentrations of 70 ppm for 5 hours (McGregor, 1981) or 750 mg/m³ (approximately 193 ppm) for 6 hours (Kramers *et al.*, 1985) were ineffective in inducing these mutations. Results from *in vitro* mammalian cell assays with methyl bromide were negative for the induction of unscheduled DNA synthesis (McGregor, 1981; Kramers *et al.*, 1985) and positive for the induction of sister chromatid exchanges (Tucker *et al.*, 1986). *In vivo* mammalian tests for the induction of sperm abnormalities in mice and dominant lethal mutations and chromosomal aberrations in rats were negative (McGregor, 1981). However, there is one report describing significant increases in the frequency of micronucleated polychromatic erythrocytes in peripheral blood and bone marrow of male and female mice and rats administered methyl bromide by inhalation 6 hours per day, 5 days per week for 2 weeks; doses ranged from 0 to 200 ppm for mice and 0 to 338 ppm for rats (Ikawa *et al.*, 1986). No data were included in the report.

Some of the metabolites of methyl bromide have been investigated for mutagenic activity. The limited information available suggests that these compounds are not mutagenic in bacteria but that one metabolite, methanol, may be clastogenic in

eukaryotic cells. Bromine induced mutation in tobacco mosaic virus (Singer and Fraenkel-Conrat, 1974) and DNA damage in *Bacillus subtilis*, as measured by differential killing of DNA-repair-deficient strains both with and without S9 (Tonogai *et al.*, 1979). The metabolite methanol has been widely tested in *S. typhimurium* for the induction of gene mutations and was uniformly negative (Florin *et al.*, 1980; De Flora, 1981; Gocke *et al.*, 1981; Kowbel *et al.*, 1982; Shimizu *et al.*, 1985; Tomoda *et al.*, 1986). Methanol was reported to induce gene mutations in yeast (Tuite *et al.*, 1981; Lund and Cox, 1981) and chromosomal aberrations in plants (DeKergommeaux *et al.*, 1983), but tests for a variety of genotoxicity endpoints in mammalian cell cultures were all negative (Obe and Ristow, 1977; Goldmacher and Thilly, 1983; Lasne *et al.*, 1984; Oya *et al.*, 1986). *In vivo* tests for the induction of somatic gene mutation (Russell and Montgomery, 1980) and micronuclei in bone marrow cells of mice (Gocke *et al.*, 1981) were negative. Methanol was reported to induce abnormal sperm morphology in B6C3F₁ mice treated with 1 g/kg orally for 5 days (Ward *et al.*, 1984). The metabolites *S*-methyl-*L*-cysteine and *S*-methylglutathione were negative for the induction of gene mutations in *S. typhimurium* (Leopold *et al.*, 1982; Stark *et al.*, 1987).

Mutagenicity data on structural analogs of methyl bromide are largely limited to bacterial assays, and positive results have been reported for all analogs that have been tested: methyl chloride, bromochloromethane, dimethyl bromide, dichloromethane, and the halogenated ethanes (Simmon *et al.*, 1977; Barber *et al.*, 1981; Gocke *et al.*, 1981). In addition, methyl chloride was reported to be positive for the induction of unscheduled DNA synthesis in *in vitro* mammalian cell assays (Working *et al.*, 1986), for gene mutations, and for sister chromatid exchanges (Fostel *et al.*, 1985); a marginal increase in unscheduled DNA synthesis in hepatocytes, but not in tracheal epithelial cells or spermatocytes, was reported in rats exposed by inhalation to extremely high concentrations (15,000 ppm) of methyl chloride (Working *et al.*, 1986). Results of dominant lethal assays in rats treated with methyl chloride, however, were negative (Working *et al.*, 1985; Chellman *et al.*, 1986; Working and Bus, 1986). Dichloromethane was weakly mutagenic in *D. melanogaster* (Gocke *et al.*, 1981) and induced chromosomal aberrations in Chinese hamster ovary cells (Thilagar and Kumaroo, 1983). Results from *in vivo* studies with

dichloromethane (Gocke *et al.*, 1981; Burek *et al.*, 1984; Sheldon *et al.*, 1987; Trueman and Ashby, 1987) are mixed, and the studies are not easily comparable in route of administration, dose, end-point assayed, and other parameters. Westbrook-Collins *et al.* (1989) presented evidence for clastogenic activity in several tissues of B6C3F₁ mice exposed by inhalation to high doses of dichloromethane. Induction of DNA single strand breaks occurred in hepatic cells of B6C3F₁ mice administered 1-bromo-2-chloroethane via intraperitoneal injection (Storer and Conolly, 1983).

DUTCH GOVERNMENT STUDIES

Toxicity studies were conducted by the National Institute of Public Health and Environmental Hygiene, Bilthoven, The Netherlands. Except for one study that has already been published (Danse *et al.*, 1984), all other studies are in technical report form. A summary of these studies follows.

Inhalation Studies: Two range-finding studies were conducted in SPF Wistar rats (Reuzel *et al.*, 1987). In the first study, groups of six male rats were exposed to 0, 150, 375, or 750 mg/m³ (equivalent to 0, 39, 96, or 193 ppm) of methyl bromide by inhalation for 6 hours per day, 5 days per week during week 1 and 3 days per week during week 2. The rats in the highest dose group had marked growth retardation (mean body weight was 76% that of the controls) as well as neurotoxic signs including tremors and motor incoordination. One rat in this group was killed moribund on the fifth exposure day. Brain weight depression ranging from 4% to 12% was observed in all dose groups and was dose related. In the highest dose group, liver weight was 26% lower than the control. Of the eight organs examined microscopically in the control and the highest dose groups, no distinct changes could be attributed to methyl bromide exposure. However, lungs of three high-dose rats were strongly hyperemic and had small focal hemorrhagic areas.

In the second range-finding study, groups of six male and six female rats were exposed to 0, 70, 200, or 600 mg/m³ (equivalent to 0, 18, 51, or 154 ppm) methyl bromide by inhalation for 6 hours per day, 5 days per week during weeks 1 to 3, and 7 days per week during week 4. Five male and three female rats in the high-dose group died before the end of the study. The rats in this group had marked reductions in feed consumption and body weight

gain. Neurobehavioral effects (disturbed gait and tremors) were clearly observed in the two highest dose groups. The most important histopathologic changes occurred in the heart and lung of rats in the high-dose group. Diffuse fatty vacuolization and diffuse myocardial fiber degeneration were observed. The lung was frequently hyperemic with dilated alveoli; in some rats, interstitial pneumonia was noted. The marginal no-effect level in this study was considered to be 70 mg/m³ (18 ppm).

Thirteen-week inhalation toxicity studies were conducted by exposing groups of ten male and ten female Wistar rats to methyl bromide at target concentrations of 0, 1, 7, or 49 ppm (actual, 0, 1, 6.5, or 42.6 ppm) for 6 hours per day, 5 days per week. No deaths occurred, and no clinical findings were observed. Body weight gain was not affected in any of the exposed groups. Leukocyte counts were 22% higher in high-dose males than in controls. Plasma alkaline phosphatase activity was lower in both high-dose males (32%) and females (53%) than in controls, and the plasma albumin concentration was 10% higher in high-dose females than in controls. The absolute and relative liver weights of high-dose males and females were 5% to 16% lower than those of controls. The only exposure-related histopathologic change occurred in the liver of high-dose male and female rats and was characterized by small hepatocytes with homogeneous eosinophilic cytoplasm. This alteration varied in degree from slight to severe and was seen in 6 of the 10 males and 7 of the 10 females. The no-adverse-effect level for these 13-week inhalation toxicity studies was considered to be 6.5 ppm.

Lifetime inhalation carcinogenicity studies of methyl bromide in Wistar rats were initiated by the Dutch government on May 28, 1982. Groups of 90 males and 80 females were exposed to 0, 3, 30, or 90 ppm methyl bromide for 6 hours per day, 5 days per week for up to 130 weeks (29 months). Groups of 10 rats were killed at weeks 14 and 27 for biochemistry studies, and at week 53 for biochemical and interim pathologic examinations or for neurotoxicity testing. Another ten male rats were not assigned to any specific group.

Methyl bromide was a mild nasal irritant at all exposure concentrations. At 90 ppm, increased mortality, decreased body weight gain, and an increased incidence of hemothorax, myocardial degeneration, and thrombi in the heart were

observed. The incidence of neoplasms was unaffected.

Gavage Studies: A single dose of methyl bromide dissolved in peanut oil was administered by gavage to rats. The LD₅₀ was found to be 214 mg/kg (range, 190 to 239 mg/kg).

Groups of six male and six female rats were administered 0, 2, 10, or 50 mg/kg methyl bromide in peanut oil by gavage 5 days per week for 4 weeks. Growth retardation was observed, particularly in the high-dose males. Methyl bromide administration had no effect on feed consumption, reflexes, or clinical pathology indices. In the high-dose group, the weights of the adrenal gland in males and the ovary in females were greater than those of control animals. Microscopic lesions, including hyperkeratosis, hyperplasia, and ulceration, were observed in the stomach of high-dose rats.

A 13-week study of rats administered methyl bromide by gavage was published by Danse *et al.* (1984) and is summarized in the short-term toxicity section of this introduction.

Teratogenicity: Pregnant rats were administered 0, 0.5, 5, 25, or 50 mg/kg methyl bromide in peanut oil by gavage on days 5 to 20 of gestation. Maternal toxicity was evident in the two highest dose groups. The most prominent effect was seen in the stomach and included hyperplasia and hyperkeratosis in the cardiac region, with occasional ulceration and inflammation in the underlying muscle layers and peritoneum. A total resorption of embryos was observed in the highest dose group and was considered to be the result of the drastically deteriorated health of the pregnant rats and not a primary toxic effect. In the control and 25 mg/kg groups, no teratogenic effects were observed in the skeleton or internal organs of fetuses. This study demonstrated that methyl bromide is not teratogenic and that it adversely affects prenatal development only when maternal toxicity is present.

Genetic Toxicology: Methyl bromide was evaluated for mutagenic properties in two bacterial systems (fluctuation test and Ames test), in two mammalian cell systems *in vitro* (gene mutation and DNA synthesis), and in *Drosophila melanogaster*. Methyl bromide was found to be mutagenic in four of the five tests. These positive tests were (1) the fluctuation test with *Klebsiella pneumoniae* at minimum concentrations of 4.75×10^3 mg/m³ in air, (2) the Ames test with *Salmonella typhimurium* TA100 at minimum concentrations of 1.9×10^3 mg/m³ in air (plate test) and at concentrations as low as 285 mg/L in suspension culture, (3) the test for gene mutations in L5178Y mouse lymphoma cells at concentrations as low as 0.3 mg/L in suspension culture, and (4) the test for sex-linked recessive lethal mutations in *Drosophila melanogaster* at the highest tested nontoxic concentration of 375 mg/m³ for 5 to 6 hours in normal air and at 200 mg/m³ for 15 to 16 hours. No effect was observed in the test for DNA synthesis in primary liver cells of rats at concentrations of 10 to 30 mg/L medium.

Other Studies: The Dutch government also conducted residual analysis of drain water and surface water during the rinsing of greenhouse soils after fumigation with methyl bromide and aquatic toxicity studies. These studies are not summarized here.

STUDY RATIONALE

Because of the high production volume, the high potential for exposure, the risk to fumigators and chemical workers, and the lack of toxicologic data, the California Department of Health Services nominated methyl bromide to the National Toxicology Program (NTP) for study. The NTP Board of Scientific Counselors, after a review of the information available on methyl bromide, recommended that carcinogenicity studies be performed by the inhalation route and that pulmonary, renal, and neurologic effects be examined. Because the Dutch government had studied the carcinogenicity of methyl bromide in rats via inhalation exposure, the NTP conducted carcinogenicity studies only in B6C3F₁ mice.

MATERIALS AND METHODS

PROCUREMENT AND CHARACTERIZATION OF METHYL BROMIDE

Methyl bromide was obtained in one lot (lot number E21-1012-00) from Matheson Gas Products (Joliet, IL) in five compressed-gas cylinders. Identity, purity, and stability analyses were conducted on representative samples from two cylinders by the analytical chemistry laboratory, Midwest Research Institute (Kansas City, MO) (Appendix G). The study chemical was identified as methyl bromide by infrared and nuclear magnetic resonance spectroscopy (Jackman and Sternhell, 1969; Craver, 1977). Lot number E21-1012-00 was found to be 99.8% pure, as determined by gas chromatography. Periodic analyses throughout the studies by the same method showed no apparent degradation of the study material.

GENERATION AND MONITORING OF CHAMBER CONCENTRATIONS

Methyl bromide was delivered as a neat gas from a compressed-gas cylinder through a shrouded delivery tube to a distribution plenum. Rotameters controlled the gas flow to each 1.4-m³ inhalation chamber.

The concentration of methyl bromide in the chambers was determined with a MIRAN 80 infrared spectrophotometer. Air from each chamber was sampled and analyzed for about 10 minutes every hour for the duration of the studies. During the 13-week studies, daily average chamber concentrations for rats ranged from 87% to 107%, and for mice, from 83% to 136% of the target concentrations. A summary of the chamber concentrations for the 13-week studies is presented in Table G1.

During the 2-year studies, measurements in the 10 ppm chamber varied from 90% to 120% of target concentration during the first week of exposure but were greater than 110% of the desired concentration only three times during the remainder of the studies. Concentrations in the 33 and 100 ppm chambers were within 10% of the desired concentration

throughout the studies. A summary of daily average exposure concentrations for the 2-year studies is presented in Figures G4, G5, and G6.

The uniformity of methyl bromide distribution in each chamber was measured in the front and back of eight ports in the chambers during the first week of exposure and at 3-month intervals throughout the 2-year studies. The spatial variation did not exceed 4.2%. Therefore, the concentrations of methyl bromide in the chambers were considered to be uniform. The buildup time was found to be rapid, as expected, taking approximately 20 minutes to reach 90% of the target concentration.

14-DAY STUDIES

Groups of five B6C3F₁ mice of each sex were exposed to air containing target concentrations of 0, 12, 25, 50, 100, or 200 ppm methyl bromide 6 hours per day 5 days a week for 10 days of exposure over 14 days. Animals were observed twice daily and were weighed at the start of the studies, after 5 days of exposure, and at the end of the studies.

All mice were necropsied; mice from the 100 and 200 ppm dose groups were examined for histopathologic lesions. Further details are presented in Table 3.

13-WEEK STUDIES

Thirteen-week studies were conducted to evaluate cumulative toxic effects of repeated exposure to methyl bromide and to determine the concentrations to be used in the 2-year studies.

Groups of 10 mice of each sex were exposed to air containing 0, 10, 20, 40, 80, or 120 ppm methyl bromide, 6 hours per day, 5 days per week for 13 weeks. Groups of 10 rats of each sex were exposed to air containing 0, 30, 60, or 120 ppm methyl bromide on the same schedule. Animals were observed twice daily; moribund animals were killed. Animal weights were recorded weekly. Further experimental details are summarized in Table 3.

At the end of the studies, blood was drawn from all animals for hematology and serum pseudocholinesterase (mice only) analyses. Hematology parameters measured are listed in Table 3. Necropsies were performed on all animals. Lungs, heart, liver, right kidney, spleen, adrenal gland (rats), brain, and left testis were weighed. Histologic examinations were performed on all control and high-dose animals necropsied. Tissues examined are listed in Table 3.

Additional groups of eight rats of each sex were exposed to air containing 0, 30, 60, or 120 ppm methyl bromide and groups of eight mice of each sex were exposed to air containing 0, 20, 40, or 80 ppm methyl bromide on the same schedule and were examined qualitatively and quantitatively for neurobehavior. Qualitative clinical observations were recorded, and quantitative behavioral assessments including grip strength, startle response time, analgesia response time, foot splay, and locomotor activity were performed. Gross and microscopic evaluations were performed on the brain, spinal cord, and peripheral nerves of four rats from each of the 0 and 120 ppm dose groups and four mice from each of the 0, 20, 40, and 80 ppm dose groups for neuromorphologic changes.

SPECIAL 6-WEEK TARGET ORGAN TOXICITY STUDIES

Six-week studies were conducted to identify target organs of methyl bromide toxicity at near-lethal concentrations. Four- to five-week-old male and female F344/N rats and B6C3F₁ mice were obtained from Simonsen Laboratories, Inc. (Gilroy, CA). Animals were observed for 13 to 14 days, distributed to weight classes, and assigned to groups according to tables of random numbers. Groups of 20 rats and mice of each sex were exposed to air containing 0 or 160 ppm methyl bromide, 6 hours per day, 5 days per week until 3 (rats only), 10, or up to 30 exposures were reached. Feed was available *ad libitum* during nonexposure periods; water was available at all times. Animal weights were recorded once weekly. Animals were observed twice daily; moribund animals were killed. When 50% mortality occurred in any group, all remaining animals in that group were killed. Further experimental details are summarized in Table 3.

Rats in the 3-exposure groups, all animals in the 10-exposure groups, and five rats and mice of each sex in the 30-exposure groups were assessed for liver

and kidney function as follows. Rats were placed in metabolism cages, and 16-hour urine samples were collected. Urine volume, specific gravity, and protein, glucose and creatinine concentrations were determined, and sediment was evaluated microscopically. Prior to necropsy, blood was drawn from the descending aorta of rats and mice and submitted for hematology and measurements of serum pseudocholinesterase levels (Table 3). Histologic examinations were performed on all animals. Tissues examined are listed in Table 3.

2-YEAR STUDIES

Study Design

A total of 86 mice per group were exposed to methyl bromide at target concentrations of 0 (chamber controls), 10, 33, or 100 ppm, 6 hours per day, 5 days per week for up to 2 years (Table 3). Ten mice from each group were scheduled for interim evaluations at 6 months and 15 months. An additional 16 mice from each group were used for neurobehavioral testing only.

Because of unexpected high mortality after 20 weeks (27/86 males and 7/86 females), all remaining mice in the 100 ppm groups were exposed to only untreated air for the rest of the studies.

The two scheduled interim evaluations for high-dose males were not carried out. Instead, all high-dose male mice predesignated for interim evaluations, including those that died early or were killed moribund, were included with the 100 ppm exposure core study group. Therefore, the core study included 70 male mice in the 100 ppm exposure group. For the 100 ppm group female mice, the 6-month interim evaluation was not carried out; however, the 15-month interim evaluation was performed. All 10 of the 100 ppm females previously designated for 6-month interim evaluation were included with the 100 ppm exposure core study group. Therefore, the core study included 60 female mice in the 100 ppm exposure group. At each interim evaluation, mortality, body weight, organ weights, hematology parameters, and gross and microscopic pathology were evaluated.

One male in the 10 ppm group died before exposure began and was not replaced. Five mice originally designated for an interim evaluation, but which died early, were included in the corresponding 2-year study groups for statistical analyses. Thus, the tumor analyses were based on the following numbers

of male mice: 0 ppm, 50; 10 ppm, 50; 33 ppm, 51; and 100 ppm, 70; and female mice: 0 ppm, 51; 10 ppm, 50; 33 ppm, 50; and 100 ppm, 62.

Neurobehavioral testing was scheduled during the preexposure period and at 3-month intervals throughout the studies. These tests were conducted for all female groups. Because of early high mortality, males in the 100 ppm neurobehavioral testing group were evaluated only before exposure; males in the control and two low-dose groups were evaluated before exposure and at 3-month intervals throughout the 2-year study. Quantitative neurobehavioral testing included the evaluation of locomotor activity, exploratory behavior, startle response, grip strength, analgesia response, and foot splay. Animals were killed at 6, 15, and 24 months, and selected animals were killed at the termination of the 100 ppm exposures for neuropathological assessment. Gross and microscopic neuromorphology of the brain, spinal cord, and peripheral nerves were evaluated.

Source and Specification of Animals

The male and female B6C3F₁ mice used in these studies were obtained from the Frederick Cancer Research Facility (Frederick, MD). Animals were shipped to the study laboratory at 4 weeks of age. Following an 8-day quarantine, five animals of each sex were randomly selected and evaluated for parasites and evidence of disease. The animals were placed on study at 6 weeks of age. The health of the animals was monitored during the course of the studies according to the protocols of the NTP Sentinel Animal Program (Appendix I).

Animal Maintenance

Mice were housed individually. Feed (Appendix H) was removed during exposure periods; otherwise, feed and water were available *ad libitum*. Cages were rotated weekly during these studies. Further details of animal maintenance are given in Table 3.

Clinical Examinations and Pathology

All animals were observed twice daily on weekdays and daily on weekends for the first year of the studies. During the second year of the studies, all animals were observed twice daily, 7 days per week. Clinical findings and body weights were recorded weekly for the first 13 to 14 weeks (control, 10 and 33 ppm groups) up to week 30 of the studies (100 ppm group), and at least once per month thereafter. Mean body weights were calculated for each group.

At end of the 2-year study, all surviving animals not designated for neurobehavioral studies were killed. Blood samples were collected from the retroorbital sinus and hematology parameters measured. The brain, heart, right kidney, liver, lung, spleen, right testis, and thymus were weighed at necropsy. During necropsy, all organs and tissues were examined for grossly visible lesions. Tissues were preserved in 10% neutral buffered formalin, embedded in paraffin, sectioned, and stained with hematoxylin and eosin. Histopathologic examinations were performed on tissues and sites specified in Table 3.

When the pathology evaluation was completed and the pathology data entered into the Toxicology Data Management System, the slides, paraffin blocks, and residual formalin-fixed tissues were sent to the NTP Archives. The slides, blocks, and residual wet tissues were audited for accuracy of labeling and animal identification and for thoroughness of tissue trimming. The slides, individual animal necropsy records, and pathology tables were sent to an independent pathology quality assessment laboratory. The individual animal records and pathology tables were compared for accuracy, slides and tissue counts were verified, and histotechnology was evaluated. All tissues with a tumor diagnosis, and the brain, heart, liver, nose, spleen, sternum, testis, and thymus from all mice were reevaluated microscopically by a quality assessment pathologist. Nonneoplastic lesions were evaluated for accuracy and consistency of diagnosis only in the potential target organs, in a randomly selected 10% of the animals, and in tissues with unusual incidence patterns or trends. Tissues were evaluated in a blind fashion (i.e., without knowledge of dose group) only if the lesions in question were subtle.

The quality assessment report and slides were submitted to the Pathology Working Group (PWG) chair, who reviewed microscopically the sternum, brain, lung, peripheral nerve, spinal cord, nose, and heart of all male and female mice evaluated at 6, 15, or 24 months, and any other tissues for which there was a disagreement in diagnosis between the laboratory and quality assessment pathologists. Representative examples of potentially chemical-related nonneoplastic lesions and neoplasms, including examples of differences in diagnosis between the study and quality assessment pathologists, were selected by the chair for review by the PWG. The PWG included the quality assessment pathologist

and other pathologists experienced in rodent toxicologic pathology, who examined the tissues without knowledge of dose groups or previously rendered diagnoses. When the consensus diagnosis of the PWG differed from that of the study pathologist, the diagnosis was changed to reflect the opinion of the PWG. Thus, the final pathology data represent a consensus of contractor pathologists and the NTP Pathology Working Group. This procedure has been described, in part, by Maronpot and Boorman (1982) and Boorman *et al.* (1985). For subsequent analysis of pathology data, the diagnosed lesions for each tissue type are evaluated separately or combined according to the guidelines of McConnell *et al.* (1986).

Statistical Methods

Survival Analyses

The probability of survival was estimated by the product-limit procedure of Kaplan and Meier (1958) and is presented in the form of graphs. Animals were censored from the survival analyses at the time they were found to be missing or dead from other than natural causes; animals dying from natural causes were not censored. Statistical analyses for a possible dose-related effect on survival used the method of Cox (1972) for testing two groups for equality and Tarone's (1975) life table test for a dose-related trend. When significant survival differences were detected, additional analyses using these procedures were carried out to determine the points in time at which significant differences in the survival curves were first detected. All reported P values for the survival analyses are two sided.

Calculation of Incidence

The incidence of neoplastic or nonneoplastic lesions is given as the ratio of the number of animals bearing such lesions at a specific anatomic site to the number of animals in which that site was examined. In most instances, the denominators include only those animals for which the site was examined histologically. However, when macroscopic examination was required to detect lesions (e.g., skin or mammary tumors) before histologic sampling, or when lesions could have appeared at multiple sites (e.g., lymphomas), the denominators consist of the number of animals on which a necropsy was performed.

Analysis of Tumor Incidence

The majority of tumors in this study were considered to be incidental to the cause of death or not rapidly lethal. Thus, the primary statistical method used was a logistic regression analysis, which assumed that the diagnosed tumors were discovered as the result of death from an unrelated cause and thus did not affect the risk of death. In this approach, tumor prevalence was modeled as a logistic function of chemical exposure and time. Both linear and quadratic terms in time were incorporated initially, and the quadratic term was eliminated if it did not significantly enhance the fit of the model. The dosed and control groups were compared on the basis of the likelihood score test for the regression coefficient of dose. This method of adjusting for intercurrent mortality is the prevalence analysis of Dinse and Lagakos (1983), further described and illustrated by Dinse and Haseman (1986). When tumors were incidental, this comparison of the time-specific tumor prevalence also provided a comparison of the time-specific tumor incidence (McKnight and Crowley, 1984).

In addition to logistic regression, alternate methods of statistical analysis were used, and the results of these tests are summarized in the appendixes. These include the life table test (Cox, 1972; Tarone, 1975), appropriate for rapidly lethal tumors, and the Fisher exact test and the Cochran-Armitage trend test (Armitage, 1971; Gart *et al.*, 1979), procedures based on the overall proportion of tumor-bearing animals.

Tests of significance include pairwise comparisons of each dosed group with controls and a test for an overall dose-response trend. Continuity-corrected tests were used in the analysis of tumor incidence, and reported P values are one sided. The procedures described above also were used to evaluate selected nonneoplastic lesions. For further discussion of these statistical methods, see Haseman (1984).

Analysis of Continuous Variables

Organ weight and organ-weight-to-body-weight ratio, behavioral, hematology and pseudocholinesterase, and cytogenetic and micronuclei data were analyzed with the control group using the nonparametric

multiple comparison test of Dunn (1964) or Shirley (1977). Jonckheere's test (Jonckheere, 1954) was used to assess the significance of the dose response trends and to determine whether Dunn's or Shirley's test was more appropriate for pairwise comparisons.

QUALITY ASSURANCE METHODS

The 13-week and 2-year studies were conducted in compliance with Food and Drug Administration Good Laboratory Practice Regulations (21 CFR Part 58). In addition, as study records were submitted to the NTP Archives, they were audited retrospectively by an independent quality assurance contractor. Separate audits covering completeness and accuracy of the pathology data, pathology specimens, final pathology tables, and staff review

draft of this NTP Technical Report were conducted. Audit procedures are presented in the reports, which are on file at the NIEHS. The audit findings were reviewed and assessed by NTP staff so that all discrepancies had been resolved or were otherwise addressed during the preparation of this Technical Report.

GENETIC TOXICOLOGY

The genetic toxicology of methyl bromide was assessed by testing its ability to induce mutations in *Salmonella typhimurium*, sister chromatid exchanges and micronuclei in mouse bone marrow cells, and micronuclei in mouse peripheral blood. The protocols and results of these studies are given in Appendix F.

TABLE 3
Experimental Design and Materials and Methods in the Inhalation Studies of Methyl Bromide

14-Day Studies	13-Week Studies	Special 6-Week Target Organ Toxicity Studies	2-Year Studies
Study Laboratory			
Brookhaven National Laboratories	Brookhaven National Laboratories	Brookhaven National Laboratories	Brookhaven National Laboratories
Strain and Species			
B6C3F ₁ mice	F344/N rats B6C3F ₁ mice	F344/N rats B6C3F ₁ mice	B6C3F ₁ mice
Animal Source			
Charles River Breeding Laboratories (Kingston, NY)	Rats: Simonsen Laboratories (Gilroy, CA). Mice: Frederick Cancer Research Facility (Frederick, MD)	Simonsen Laboratories (Gilroy, CA)	Frederick Cancer Research Facility (Frederick, MD)
Time Held Before Study			
8 days	Rats: 7-10 days Mice: 7 days	10 days	14 days
Age When Placed on Study			
6-7 weeks	Rats: 6 weeks. Mice: 7 weeks	6-7 weeks	6 weeks
Doses			
0, 12, 25, 50, 100, or 200 ppm methyl bromide by inhalation	Rats: 0, 30, 60, or 120 ppm methyl bromide by inhalation Mice: 0, 10, 20, 40, 80, or 120 ppm methyl bromide by inhalation	0 or 160 ppm methyl bromide by inhalation	0, 10, 33, or 100 ppm methyl bromide by inhalation
Date of First Dose			
2 March 1983	Rats: 9-10 November 1983 or 7 November 1983 (neurobehavioral groups). Mice: 6 July 1983, 11 July 1983 (neurobehavioral groups)	24 July 1984 (rats given 3 exposures); 25 July 1984 (remaining rats); 25 July 1984 (mice)	26 September 1984
Duration of Dosing			
6 hours/day for 10 exposures over 14 days	6 hours/day, 5 days/week for 13 weeks	6 hours/day for 3 (rats only) 10, or 30 exposures	10 or 33 ppm groups: 6 hours/day, 5 days/week for 6 months, 15 months, or 103 weeks; 100 ppm group: 6 hours/day, 5 days/week for 20 weeks, followed by 84 weeks of observation

TABLE 3
Experimental Design and Materials and Methods in the Inhalation Studies of Methyl Bromide (continued)

14-Day Studies	13-Week Studies	Special 6-Week Target Organ Toxicity Studies	2-Year Studies
Date of Last Dose 15 March 1983	Rats: 7-8 February 1984 or 3 February 1984 (neurobehavioral groups). Mice: 4-5 October 1983, 6 October 1983 (neurobehavioral groups)	26 July 1984 (rats given 3 exposures); 7 August 1984 (rats given 10 exposures) 13 August 1984-5 September 1984 (rats given 30 exposures); 7 August 1984 or 14 August 1984 (mice)	15 September 1986 (100 ppm group: 13 February 1985)
Necropsy Dates 16 March 1983	Rats: 8-9 February 1984 Mice: 5-6 October 1983	3 exposures: 27 July 1984; 10 exposures: 8 August 1984; 2 August 1984 (female mice); 30 exposures: 14 August 1984 (male rats); 6 September 1984 (female rats); 8 August 1984 (male mice); 2 August 1984 (female mice)	6-month interim evaluation: 27-28 March 1985; 15-month interim evaluation: 2-3 January 1986; terminal sacrifice: 22-26 September 1986
Age at Necropsy 8-9 weeks	Rats: 19 weeks Mice: 20 weeks	Rats: 7-13 weeks Mice: 8-9 weeks	110-111 weeks for terminal sacrifice
Size of Study Groups 5 males and 5 females	10 males and 10 females of each species; 8 males and 8 females of each species for the neurobehavioral studies	20 males and 20 females of each species	70 males and 70 females for the 6- and 15-month interim and the 2-year study; 16 males and females for the neurobehavioral studies
Method of Animal Distribution Distributed to weight classes and then assigned to cages by one table of random numbers and to groups by another table of random numbers	Same as 14-day studies	Same as 14-day studies	Same as 14-day studies
Animals per Cage 3	Rats: 1 Mice: 3	1	1
Method of Animal Identification Toe clip	Rats: metal neck tag Mice: toe clip	Toe clip	Toe clip; ear tags for neurobehavioral groups

TABLE 3
Experimental Design and Materials and Methods in the Inhalation Studies of Methyl Bromide (continued)

14-Day Studies	13-Week Studies	Special 6-Week Target Organ Toxicity Studies	2-Year Studies
Feed NIH-07 Rat and Mouse Ration (Zeigler Bros., Inc., Gardners, PA); available <i>ad libitum</i> during nonexposure periods	Same as 14-day studies	Same as 14-day studies	Same as 14-day studies
Water Available <i>ad libitum</i> . Automatic watering system (Hazleton Systems, Aberdeen, MD); chlorine-treated water from wells.	Same as 14-day studies	Same as 14-day studies	Same as 14-day studies
Cages Stainless steel wire (Harford Metal, Inc., Aberdeen, MD)	Same as 14-day studies	Same as 14-day studies	Same as 14-day studies
Chambers Stainless steel and glass or Lucite chambers. (Hazleton Systems, Aberdeen, MD)	Same as 14-day studies	Same as 14-day studies	Same as 14-day studies
Animal Room Environment Light: fluorescent, 12 hours/day Chamber air: 15 changes/hour	Rats: temperature: 74° ± 2°F relative humidity: 11%-70% Mice: temperature: 68°-76°F relative humidity: 50%-70% Light: fluorescent, 12 hours/day	Temperature: 65°- 82°F (at least 90% of the time) Relative humidity: 44%-87% Light: fluorescent, 12 hours/day Room air: 15 changes/hour	Temperature: 65°- 82°F Relative humidity: 11%-85% Light: fluorescent, 12 hours/day
Other Chemicals on Study in the Same Room None	None	None	None
Type and Frequency of Observation Weighed the day before the first exposure, on day 8, and at the end of the studies	Observed twice daily during the week and daily on weekends; weighed 1 time per week	Observed twice daily, 7 days per week; weighed before first exposure, once per week, and just before necropsy	Observed twice daily on weekdays (daily on weekends for 1 year); weighed 1 time per week for 13 weeks, 1 time per 4 weeks for 18 months, and then 1 time per 2 weeks

TABLE 3
Experimental Design and Materials and Methods in the Inhalation Studies of Methyl Bromide (continued)

14-Day Studies	13-Week Studies	Special 6-Week Target Organ Toxicity Studies	2-Year Studies
<p>Necropsy Necropsy performed on all animals</p>	<p>Necropsy performed on all animals. Adrenal gland (rats), brain, heart, kidney, liver, lung, spleen (rats), testis, and thymus (mice) were weighed.</p>	<p>Necropsy performed on all animals. Adrenal gland (rats), brain, heart, right kidney, liver, lungs, spleen, right testis, and thymus were weighed.</p>	<p>Necropsy performed on all animals not used in the neurobehavioral studies. Brain, heart, right kidney, liver, lungs, spleen, right testis, and thymus were weighed.</p>
<p>Clinical Pathology None</p>	<p>Hematology: leukocytes, erythrocytes, hematocrit, hemoglobin, mean cell volume, mean cell hemoglobin, mean cell hemoglobin concentration. Clinical Chemistry: Pseudocholinesterase activities (mice) Urinalysis: None</p>	<p>Hematology: erythrocytes, hematocrit, hemoglobin, mean cell volume, mean cell hemoglobin, mean cell hemoglobin concentration, leukocyte count and differential Clinical Chemistry: creatinine, sorbitol dehydrogenase, serum aspartate amino- transferase, and serum alanine aminotransferase. Urinalysis: protein, glucose, volume, specific gravity, creatinine, and sediment determinations on 16-hour urine samples from 5 male and 5 female rats receiving 3, 10, or 30 exposures.</p>	<p>Hematology (months 6, 15, and terminal): erythrocytes, hematocrit, hemoglobin, platelets, mean cell volume, mean cell hemoglobin, mean cell hemoglobin concentration, leukocyte count and differential. Clinical Chemistry: None Urinalysis: None</p>
<p>Histopathology Histologic exams performed on surviving males and females in control, 100, and 200 ppm groups. Tissues examined included adrenal glands, brain, epididymis, esophagus, gallbladder, gross lesions, heart, intestines (duodenum, jejunum, ileum, cecum, colon, rectum), kidney, liver, lungs with mainstem bronchi, lymph nodes (mandibular or mesenteric), mammary gland, nasal turbinates, (continued on next page)</p>	<p>Histologic exams performed on all controls and high-dose animals and on early death animals. Tissues examined included adrenal glands, brain, cecum, colon, duodenum, epididymis/seminal vesicles/prostate/testes or ovaries/uterus, esophagus, femur including marrow, gallbladder (mice), gross lesions and tissue masses, heart, ileum, jejunum, kidneys, larynx, liver, lungs and mainstem bronchi, mammary gland, (continued on next page)</p>	<p>Histologic exams performed on all animals. Tissues examined included adrenal glands, brain, heart, kidneys, liver, lungs, nasal passage, spleen, testes, and thymus.</p>	<p>Tissues examined same as 13-week studies excluding preputial and clitoral glands, with the addition of bronchial lymph nodes, costochondral junction, sternbrae including marrow, gallbladder, mandibular lymph nodes and mediastinal lymph nodes, oral cavity, sciatic nerve, and spinal cord.</p>

TABLE 3
Experimental Design and Materials and Methods in the Inhalation Studies of Methyl Bromide (continued)

14-Day Studies	13-Week Studies	Special 6-Week Target Organ Toxicity Studies	2-Year Studies
<p>Histopathology (continued) ovaries, pancreas, parathyroid glands, pituitary gland, prostate gland, salivary gland, sciatic nerve, skin, spleen, sternum (with marrow), stomach, testes, thymus, thyroid gland, trachea, urinary bladder, and uterus.</p>	<p>mesenteric lymph nodes, nasal cavity and turbinates, pancreas, parathyroid glands, pituitary gland, preputial or clitoral gland, rectum, salivary glands, skin, spleen, sternebra or vertebra (mice), stomach, thymus, thyroid gland, trachea, and urinary bladder.</p>	None	<p>Neurobehavioral assessments on 16 males and 16 females per dose group; quantitative (every 3 months): locomotor activity, exploratory behavior, startle response, grip strength, analgesia response, and foot splay. Neuromorphologic assessments (on 3-8 animals per selected group at 20 weeks, 6, 15, and 24 months): evaluation of brain, spinal cord and peripheral nerves.</p>
<p>Neurobehaviorial Studies None</p>	<p>Neurobehavioral assessments conducted on 8 rats per sex per dose group at weeks 0, 3, 6, 9, and 13 and on 8 mice per sex in the 0, 20, 40, and 80 ppm groups at weeks 0, 6, 12. Neuromorphologic studies conducted on 4 male and 4 female rats from the control and high-dose group and on 4 mice per sex per behavior dose group, including examination of brain, spinal cord, and peripheral nerves.</p>	None	

RESULTS

14-DAY STUDIES

Nine male and six female mice exposed to 200 ppm methyl bromide died before the end of the studies. No other deaths or body weight changes were related to methyl bromide exposure (Table 4). Neurobehavioral signs including trembling, jumpiness, and paralysis were observed in all groups but were most pronounced in the three highest dose groups (50, 100, 200 ppm). Bloody urine was seen on day 6 and thereafter in the cage catch pans of

the mice exposed to 200 ppm. No consistent dose-related effects were noted for hematology parameters or pseudocholinesterase activity.

Minimal hyperemia of the lung, liver, and kidneys was seen in the 200 ppm females. None of the mice had kidney or urinary bladder lesions that could have accounted for the apparent hematuria; nor were there brain or sciatic nerve lesions that could have accounted for the behavioral changes.

TABLE 4
Survival and Mean Body Weights of Mice in the 14-Day Inhalation Studies of Methyl Bromide

Dose (ppm)	Survival ^a	Mean Body Weights ^b (g)			Final Weight Relative to Controls (%)
		Initial	Final	Change	
Male					
0	10/10	20.3 ± 0.2	22.6 ± 0.2	2.3	
12	10/10	20.7 ± 0.2	23.3 ± 0.4	2.6	103
25	10/10	20.2 ± 0.4	22.3 ± 0.3	2.2	99
50	10/10	20.1 ± 0.3	22.6 ± 0.3	2.5	100
100	10/10	20.9 ± 0.3	23.5 ± 0.4	2.6	104
200	1/10 ^c	20.6 ± 0.2	— ^d	—	—
Female					
0	10/10	17.2 ± 0.3	19.7 ± 0.3	2.5	
12	10/10	17.4 ± 0.3	20.0 ± 0.4	2.6	102
25	10/10	16.7 ± 0.3	19.4 ± 0.4	2.7	98
50	10/10	16.6 ± 0.4	19.8 ± 0.4	3.2	100
100	10/10	17.4 ± 0.3	20.1 ± 0.4	2.7	102
200	4/10 ^e	16.8 ± 0.3	—	—	—

^a Number surviving/number initially in group

^b Weights given as mean ± standard error. Differences from the control group are not significant by Dunn's or Shirley's test.

^c Day of death: 11, 11, 11, 12, 12, 12, 12, 13, 14

^d Not calculated due to decrease in survival.

^e Day of death: 11, 11, 12, 13, 13, 13

13-WEEK STUDIES

Mice

Exposure to methyl bromide at 0, 10, 20, 40, 80, or 120 ppm for 13 weeks elicited little organ-specific toxicity in mice. The most noteworthy findings were a significant decrease in weight gain (58%) relative to the controls and a 17% (4/24) mortality rate in males exposed to 120 ppm (Table 5). No consistent biologically significant organ weight changes were observed (Tables C3 and C4). Clinical findings in mice exposed to 120 ppm during the studies included severe curling and crossing of the hindlimbs and twitching of the forelimbs. These signs were dose and time related and were more severe in males than in females. Mild neurobehavioral

responses reached a maximum after about 6 weeks of exposure with no increase in severity in the latter 7 weeks of the studies (Table D2). There were no significant changes in pseudocholinesterase levels. Mean cell hemoglobin and mean cell volume were lower and erythrocyte count was greater in the male mice exposed to 40 ppm, 80 ppm, or 120 ppm methyl bromide than in controls. Hemoglobin was increased in 120 ppm males as well. Although statistically significant changes were seen in females, no dose-related pattern was evident (Table E2).

No compound-induced histopathologic changes were seen in mice of either sex exposed to 120 ppm, including mice killed moribund before the end of the studies.

TABLE 5
Survival and Mean Body Weights of Mice in the 13-Week Inhalation Studies of Methyl Bromide

Dose (ppm)	Survival ^a		Mean Body Weights ^b (g)			Final Weight Relative to Controls (%)
	Toxicity Studies	Other Studies ^c	Initial	Final	Change	
Male						
0	10/10	17/17	22.4 ± 0.2	29.0 ± 0.4	6.5 ± 0.3	
10	10/10	8/8	21.6 ± 0.3	30.1 ± 0.3	8.4 ± 0.3	104
20	10/10	17/17	22.0 ± 0.3	28.3 ± 0.7	6.3 ± 0.7	98
40	10/10	17/17	21.9 ± 0.5	28.7 ± 0.7	6.8 ± 0.6	99
80	8/8	16/16	21.4 ± 0.4	27.9 ± 0.8	6.4 ± 0.6	96
120	10/10	10/14 ^d	21.7 ± 0.3	25.5 ± 0.7**	3.8 ± 0.6*	88
Female						
0	10/10	20/20	17.1 ± 0.3	23.1 ± 0.4	6.0 ± 0.4	
10	10/10	10/10	17.0 ± 0.2	23.5 ± 0.3	6.4 ± 0.3	102
20	10/10	20/20	17.5 ± 0.2	23.5 ± 0.3	6.0 ± 0.3	102
40	10/10	19/19	17.1 ± 0.2	23.8 ± 0.4	6.7 ± 0.3	103
80	8/8	16/16	16.7 ± 0.4	23.8 ± 0.4	7.2 ± 0.4	103
120	10/10	14/14	17.1 ± 0.2	23.3 ± 0.2	6.2 ± 0.2	101

* Significantly different ($P \leq 0.05$) from the control group by Dunn's or Shirley's test.

** $P \leq 0.01$

^a Number surviving/number initially on study.

^b Weights given as mean ± standard error.

^c Other studies include extra animals and animals predesignated for genetic toxicology or neurobehavioral studies.

^d Week of death: 9, 11, 13, 13

Rats

All rats lived to the end of the studies. Little or no effect was seen in rats exposed by inhalation to methyl bromide at concentrations of 0, 30, 60, or 120 ppm for 13 weeks. Significant decreases in mean body weight gain were seen in males and females exposed to 120 ppm and females exposed to 60 ppm (Table 6). No consistent organ weight changes were observed (Tables C1 and C2). Minor neurobehavioral changes were noted among both 120 ppm males and females (Table D1). Females in

the 120 ppm group had significantly lower hematocrit, hemoglobin, and erythrocyte counts than those of the controls. These changes were not seen in the 120 ppm males (Table E1).

Olfactory epithelial dysplasia and cysts, characterized by irregularity in mucosal thickness and focal cavitated spaces were seen in male and female rats in the 120 ppm dose group (dysplasia-males: control, 2/10; low-dose, 3/10; mid-dose, 2/9; high-dose, 7/10; females: 1/10; 1/10; 4/10; 8/10; cysts-males: 0/10; 0/10; 0/9; 7/10; females: 0/10; 0/10; 0/10; 9/10).

TABLE 6
Survival and Mean Body Weights of Rats^a in the 13-Week Inhalation Studies of Methyl Bromide

Dose (ppm)	Survival ^b	Mean Body Weights ^c (g)			Final Weight Relative to Controls (%)
		Initial	Final	Change	
Male					
0	10/10	120 ± 3.8	306 ± 7.1	186 ± 6.3	
30	10/10	127 ± 4.6	325 ± 5.0	198 ± 4.1	106
60	9/9 ^d	121 ± 4.9	293 ± 7.6	172 ± 4.6	96
120	10/10	121 ± 3.9	268 ± 8.6**	147 ± 6.0**	88
Female					
0	10/10	99 ± 2.4	191 ± 2.6	92 ± 2.7	
30	10/10	100 ± 2.4	184 ± 2.5	84 ± 3.8	96
60	10/10	99 ± 2.4	179 ± 3.6*	80 ± 3.8*	94
120	10/10	98 ± 3.1	166 ± 3.6**	68 ± 2.6**	87

* Significantly different ($P \leq 0.05$) from the control group by Dunn's or Shirley's test.

** $P \leq 0.01$

^a Includes only those rats assigned to the core toxicology studies (10 per sex per dose group).

^b Number surviving/number initially in group.

^c Weights given as mean ± standard error.

^d One animal in the core study group was found to be a missexed female and was removed from the study.

SPECIAL 6-WEEK TARGET ORGAN STUDIES

The 6-week studies were conducted in rats and mice to identify target organ toxicity. A paper published by Eustis *et al.* (1988) provides detailed results of these studies (see Appendix J), which are briefly summarized in this section.

Mortality rates exceeded 50% in the male mice, female mice, and male rats after 8, 6, and 14 exposures to 160 ppm. Only female rats survived the entire 30 exposures to 160 ppm methyl bromide over the 6-week period with less than 50% mortality. Toxic lesions were identified in the brain, kidney, nasal cavity, heart, adrenal gland, liver, and testis. Kidneys of the rats were unaffected by exposure, whereas nephrosis (necrosis of proximal tubule epithelium) in mice caused increased morbidity and mortality. The brain, nasal mucosa, and heart were affected in both species. Brain lesions in rats consisted of neuronal necrosis in the thalamus, hippocampus, and cerebral cortex. Cerebral neuronal necrosis was also seen in mice. Neuronal necrosis was seen in the cerebellar granular cell layer of rats and mice, but was more pronounced in mice. Necrosis of the nasal olfactory epithelium was most pronounced in female rats but was also noted in male rats and in both sexes of mice; by day 3 of exposure, necrosis was extensive, and by day 10, a single or stratified layer of flattened cells resembling those of the respiratory mucosa was present. Myocardial degeneration was also more prominent in rats than in mice and was characterized by swelling, vacuolization, and hyalinization of myofibers with increased accumulation of interstitial mononuclear cells.

2-YEAR STUDIES

6-Month Interim Evaluations

No significant treatment-related lesions were observed. Minimal cytoplasmic vacuolation of the brain, spinal cord, and peripheral nerve was observed in male mice. The vacuolation was characterized by clear spaces within the neuropil of the brain stem, white matter of the spinal cord, and axons of peripheral nerves. A slightly increased incidence was observed in treated males, especially in the low-dose group. However, similar vacuolation may occur in neural tissue as an artifact of fixation, and it was therefore uncertain if the vacuolation was an effect of treatment. No tumors were observed.

15-Month Interim Evaluations

Treatment-related effects were seen in the brain, sternum, and heart of treated mice, primarily females (100 ppm males were not sacrificed due to poor survival). The changes were essentially the same as those seen at the 2-year terminal sacrifice. Cardiac (1/8, 13%) and cerebellar (2/8, 25%) degeneration occurred in females exposed to 100 ppm methyl bromide. Sternum dysplasia was observed in one male and one female (10%) exposed to 33 ppm and one female (13%) exposed to 100 ppm. Tumors observed included four hepatocellular adenomas (control, 1/10; 10 ppm, 3/9), one alveolar/bronchiolar adenoma in a 10 ppm male, one alveolar/bronchiolar carcinoma in a 33 ppm male, and two adrenal gland tumors (a pheochromocytoma in a 33 ppm female and a hemangiosarcoma in a control female).

Neurobehavioral Assessment

In the original experimental design, 16 male and 16 female mice from each of the four dose groups (0, 10, 33, or 100 ppm) were designated to be tested every 3 months for behavioral changes. Because of the early mortality in high-dose males, only the males in the control and the two lower dose groups were tested after the third month. Females in all dose groups were tested throughout the 2-year period. Quantitative neurobehavioral testing revealed significant differences in the behavior of the high-dose males at 3 months (Table D3). In general, the animals were less active and manifested a heightened sensitivity in the startle response compared to mice in the other dose groups. In addition, the hindlimb grip scores and hot plate latency were higher in this dose group than in the others. After 6 months of exposure, the 100 ppm females had significantly lower activity scores than females in the other groups, but their higher startle responses had disappeared. After 9 months of exposure, no behavioral differences were apparent; however, at the 24-month testing period, the lower activity and heightened startle response reappeared in the 100 ppm females. There were no consistent neurobehavioral differences in animals from the two lower dose groups.

Body Weights, Organ Weights, and Clinical Findings

Final mean body weights of male and female mice exposed to 100 ppm methyl bromide by inhalation were 33% and 27% lower than those of controls. (Tables 7 and 8; Figure 1). Significant differences in mean body weights of high-dose mice appeared by week 11 and persisted throughout the end of the studies even though methyl bromide exposure was terminated at week 20. These reduced body weights made it difficult to interpret changes in absolute and relative organ weights. The only biologically significant change appeared to be reduced absolute and relative thymus weights in both sexes (Tables C9 and C10).

Although methyl bromide exposure was terminated after week 20, clinical signs of toxicity were observed in the 100 ppm animals throughout the studies. One control, five low-dose, and nine mid-dose mice also displayed clinical signs indicative of toxicity. These included tremors, abnormal posture (curvature of the spine), and limb paralysis. These signs persisted once they occurred; animals generally did not recover.

Hematology Evaluations

Scattered statistically significant differences in hematology values were not biologically significant (Table E3).

TABLE 7
Mean Body Weights and Survival of Male Mice in the 2-Year Inhalation Study of Methyl Bromide

Weeks on Study	0 ppm		10 ppm			33 ppm			100 ppm		
	Av. Wt. (g)	No. of Survivors	Av. Wt. (g)	Wt. (% of controls)	No. of Survivors	Av. Wt. (g)	Wt. (% of controls)	No. of Survivors	Av. Wt. (g)	Wt. (% of controls)	No. of Survivors
1	22.9	86	22.8	100	85	21.6	94	85 ^a	21.3	93	86 ^a
2	24.3	86	24.3	100	85	23.5	97	85	24.1	99	85
3	25.5	86	25.4	100	85	24.9	98	85	25.0	98	85
4	26.5	86	26.5	100	85	26.1	99	85	25.8	97	85
5	27.6	86	27.6	100	85	27.1	98	85	26.5	96	85
6	28.3	86	28.2	100	85	28.1	99	85	27.3	97	85
7	29.5	86	28.9	98	85	28.8	98	85	27.9	95	85
8	29.7	86	29.6	100	85	29.4	99	85	28.2	95	85
9	30.1	86	30.4	101	85	30.1	100	85	29.2	97	85
10	30.9	86	31.1	101	85	30.8	100	85	29.9	97	85
11	31.1	86	31.2	100	85	31.1	100	85	30.0	97	84
12	31.7	86	31.5	99	85	31.7	100	85	29.4	93	82
13	31.9	86	33.4	105	85	32.4	102 ^b	85	28.6	90	76
14						33.7	-	85	28.5	-	72
15									29.9	-	72
16									30.5	-	72
17									30.8	-	72
18	34.8	86	34.9	100	85	35.2	101	85	31.0	89	72
19									30.2	-	68
20									29.8	-	59
21 ^c									29.3	-	45
22 ^c	37.7	86	36.4	97	84	37.6	100	85	29.0	77	41
23									29.5	-	41
24									27.9	-	41
25									27.8	-	41
26 ^c	36.1	83	35.9	99	83	36.9	102	83	26.9	75	40
27									28.1	-	40
28									29.0	-	39
29									29.5	-	39
30 ^c	40.1	70	39.7	99	70	40.8	102	71	30.7	77	39
34	42.2	69	42.3	100	70	42.7	101	71	30.2	72	39
38	43.3	69	43.3	100	70	43.6	101	71	30.2	70	38
42	45.5	69	45.9	101	70	45.7	100	71	30.5	67	37
46	45.8	69	45.9	100	70	45.7	100	71	29.8	65	37
50	46.7	69	45.8	98	70	46.3	99	71	30.5	65	37
54	47.1	69	46.6	99	68	46.5	99	71	30.1	64	35
58	46.8	69	46.5	99	68	46.8	100	71	29.5	63	33
62	47.4	69	46.4	98	67	46.3	98	71	30.5	64	31
66 ^c	48.2	68	46.5	97	64	46.7	97	67	30.3	63	31
70 ^c	46.9	55	46.9	100	53	46.4	99	56	30.1	64	29
74	48.2	53	47.3	98	53	46.7	97	56	31.1	65	27
78	47.5	53	47.6	100	53	46.7	98	55	30.5	64	26
82	47.7	53	46.8	98	52	46.2	97	54	31.4	66	21
86	46.8	53	45.5	97	52	45.7	98	53	31.1	67	20
90	48.1	51	46.3	96	52	47.0	98	50	31.7	66	20
92	47.7	51	47.1	99	51	46.4	97	49	31.6	66	20
94	47.8	51	46.7	98	50	46.6	98	49	31.9	67	19
96	47.9	50	46.7	98	50	46.8	98	47	31.9	67	19
98	48.0	50	46.3	97	50	46.4	97	47	31.3	65	19
100	47.7	50	46.5	98	49	46.4	97	46	32.0	67	18
102	47.2	49	46.5	99	46	32.7	69	18			
Terminal sacrifice		48			45			46			17
Mean for weeks											
1-13	28.5		28.5	100		28.1	99		27.2	95	
14-52	41.4		41.1	99		40.8	99		29.5	71	
53-102	47.6		46.6	98		45.6	96		31.0	65	

^a The number of animals weighed for this week is fewer than the number of animals surviving.

^b No data calculated; control group not weighed.

^c Interim evaluation occurred during weeks 21 and 22, between weeks 26 and 30, and between weeks 66 and 70.

TABLE 8
Mean Body Weights and Survival of Female Mice in the 2-Year Inhalation Study of Methyl Bromide

Weeks on Study	0 ppm		10 ppm			33 ppm			100 ppm		
	Av. Wt. (g)	No. of Survivors	Av. Wt. (g)	Wt. (% of controls)	No. of Survivors	Av. Wt. (g)	Wt. (% of controls)	No. of Survivors	Av. Wt. (g)	Wt. (% of controls)	No. of Survivors
1	18.1	85	18.2	101	86	17.6	97	86 ^a	17.0	94	86 ^a
2	19.3	85	19.4	101	86	18.3	95	86	18.6	96	86
3	20.5	85	20.4	100	86	19.1	93	86	19.0	93	86
4	21.4	85	21.5	101	86	20.4	95	86	19.6	92	86
5	22.1	85	22.1	100	86	21.5	97	86	20.8	94	86
6	22.8	85	22.9	100	86	22.3	98	86	21.7	95	86
7	24.1	85	23.2	96	86	22.4	93	86	21.9	91	85
8	23.7	85	23.5	99	86	22.8	96	86	22.4	95	85
9	23.9	84	24.1	101	86	23.1	97	86	23.5	98	85
10	24.8	84	24.4	98	86	23.8	96	86	23.7	96	85
11	25.3	84	25.2	100	86	24.2	96	86	23.7	94	85
12	25.5	84	25.4	100	86	24.9	98	86	23.9	94	85
13	25.7	84	26.9	105	86	25.4	99 ^b	86	23.9	93	85
14						26.3	-	86	23.8	-	84
15									24.8	-	83
16									25.2	-	83
17									25.5	-	83
18	26.9	84	26.4	98	86	26.0	97	86	25.2	94	82
19									24.7	-	80
20									24.8	-	79
21 ^c									25.5	-	76
22 ^c	30.0	84	28.6	95	86	28.4	95	86	24.7	82	72
23									25.5	-	72
24									25.0	-	72
25									26.4	-	72
26 ^c	27.9	81	27.6	99	86	27.2	98	84	25.6	92	72
27									26.9	-	72
28									27.1	-	72
29									27.1	-	72
30 ^c	32.0	65	31.3	98	71	30.9	97	72	29.0	91	72
34	34.0	68	33.3	98	71	31.9	94	72	29.1	86	72
38	35.9	68	34.9	97	71	33.6	94	72	30.0	84	71
42	37.5	68	37.0	99	71	34.3	92	72	31.4	84	71
46	39.4	68	38.7	98	71	36.3	92	72	32.4	82	70
50	39.7	68	38.2	96	71	36.4	92	72	32.8	83	70
54	41.3	67	40.0	97	71	36.7	89	72	32.4	79	70
58	40.8	67	39.6	97	71	36.6	90	72	32.2	79	69
62	41.6	65	40.8	98	71	37.8	91	72	33.3	80	68
66 ^c	42.0	62	40.3	96	68	37.4	89	68	33.9	81	64
70 ^c	42.2	52	41.7	99	55	39.1	93	58	33.1	78	55
74	42.6	51	42.2	99	54	38.4	90	58	32.8	77	54
78	43.0	50	42.1	98	54	39.3	91	58	33.6	78	54
82	43.0	50	42.0	98	54	38.6	90	58	32.5	76	53
86	42.8	50	41.8	98	53	39.0	91	57	32.8	77	52
90	43.7	49	43.5	100	52	40.5	93	55	32.7	75	50
92	43.5	48	43.9	101	51	40.5	93	55	32.7	75	50
94	44.7	48	44.3	99	50	41.4	93	54	32.2	72	49
96	44.6	48	45.0	101	50	42.1	94	54	32.9	74	47
98	44.4	46	43.8	99	50	40.7	92	54	32.1	72	47
100	44.5	46	44.3	100	50	40.9	92	53	32.5	73	46
102	44.8	46	40.9	91	52	33.2	74	46			
Terminal sacrifice		43			48			51			46
Mean for weeks											
1-13	22.9		22.9	100		22.0	96		21.5	94	
14-52	33.7		32.9	98		31.1	92		26.9	80	
53-102	43.1		42.3	98		38.9	90		32.8	76	

^a The number of animals weighed for this week is less than the number of animals surviving.

^b No data calculated; control group not weighed.

^c Interim evaluation occurred during weeks 21 and 22, between weeks 26 and 30, and between weeks 66 and 70.

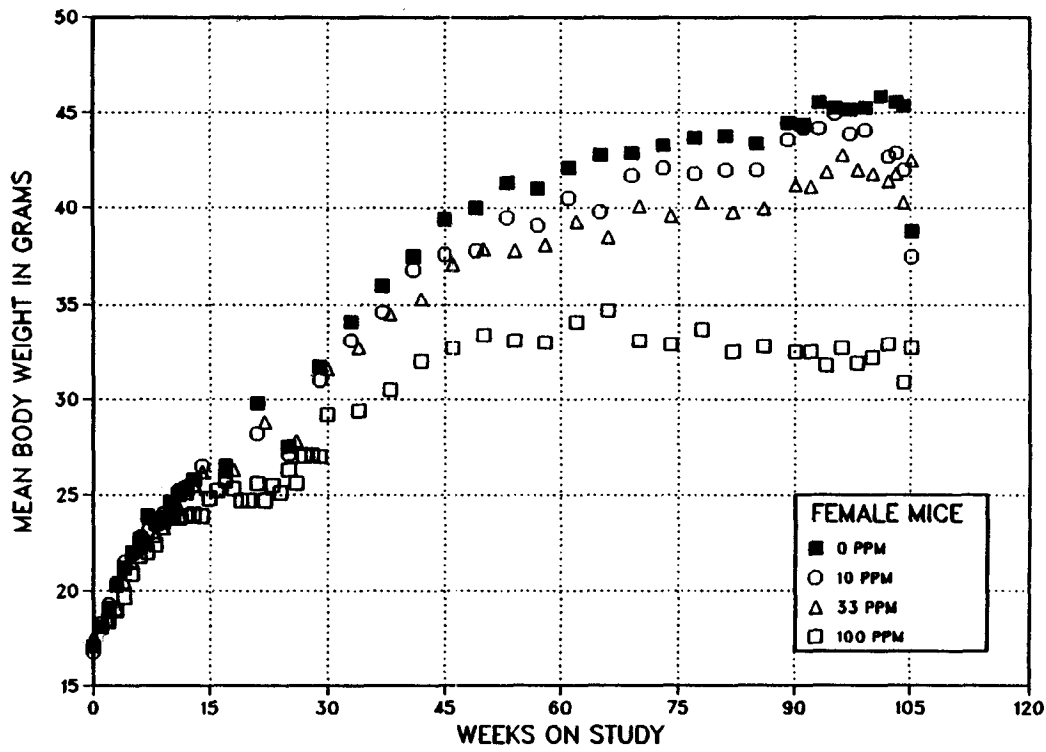
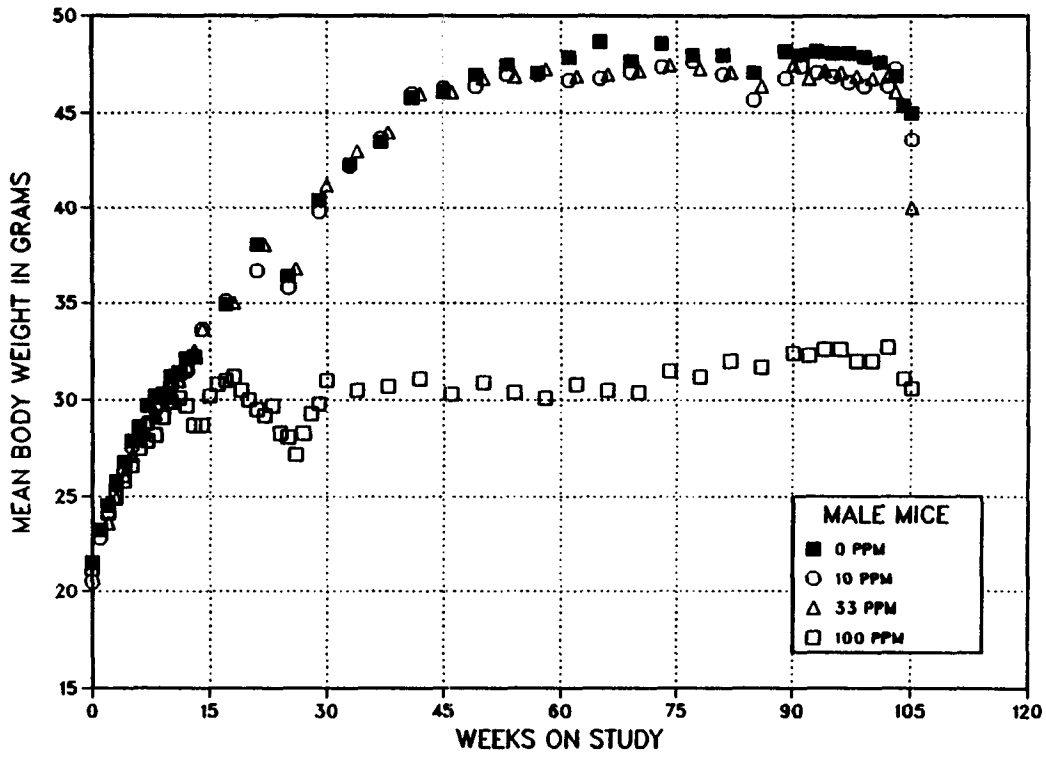

FIGURE 1
Growth Curves for Mice in the 2-Year Inhalation Studies of Methyl Bromide

Survival

The 100 ppm dose groups experienced significant early mortality (Tables 7 and 8). Methyl bromide exposures were terminated in the 100 ppm chambers at week 20, when male mortality exceeded 31% and female mortality reached 8%. The rate of mortality slowed in this dose group after exposure was terminated.

Survival rates of mice in the lower dose groups were similar to controls (Table 9): 74% to 80% of the males survived, and 82% to 90% of the females survived. Of the 100 ppm mice, only 23% of the males and 65% of the females survived. Kaplan-Meier survival curves are shown in Figure 2.

TABLE 9
Survival of Mice in the 2-Year Inhalation Studies of Methyl Bromide

	0 ppm	10 ppm	33 ppm	100 ppm
Male				
Animals initially in study	86	85 ^a	86	86
Neurobehavioral study groups ^b	16	16	16	16
Natural deaths	0	0	1	4
Moribund kills	0	0	1	8
Animals surviving to study termination	16	16	14	4
2-Year study groups	70	69 ^a	70	70
6-month interim evaluation ^b	10	10	9	- ^c
15-month interim evaluation ^b	10	9	10	--
Natural deaths	6	9	4	14
Moribund kills	3	4	6	40
Accidental deaths ^b	1	0	1	0
Animals surviving to study termination	40	37	40	16
Percent survival at end of study ^d	82	74	80	23
Mean survival days ^e	699	679	680	374
Survival analysis ^f	P<0.001	P=0.425	P=0.957	P<0.001
Female				
Animals initially in study	87	86	86	86
Neurobehavioral study groups ^a	16	16	16	16
Natural deaths	0	1	1	0
Moribund kills	0	1	1	2
Animals surviving to study termination	16	14	14	14
2-Year study groups	71	70	70	70
6-month interim evaluation ^a	10	10	10	0
15-month interim evaluation ^a	9	10	10	8
Natural deaths	7	3	1	6
Moribund kills	9	6	4	16
Animals surviving to study termination	36	41	45	40
Percent survival at end of study ^d	71	82	90	65
Mean survival days ^e	672	696	721	602
Survival analysis ^f	P=0.044	P=0.263N	P=0.023N	P=0.440

^a One male mouse predesignated for the 2-year study died before initiation of methyl bromide exposure and was not replaced.

^b Censored from survival analyses

^c Interim evaluations not performed on male mice exposed to 100 ppm.

^d Kaplan-Meier determinations. Survival rates adjusted for interim evaluations, neurobehavioral study animals, and accidental deaths.

^e Mean of all deaths (uncensored, censored, terminal sacrifice).

^f The entry under the "0 ppm" column is the trend test (Tarone, 1975) result. Subsequent entries are the results of pairwise tests (Cox, 1972). A negative trend or lower mortality in a dose group is indicated by N.

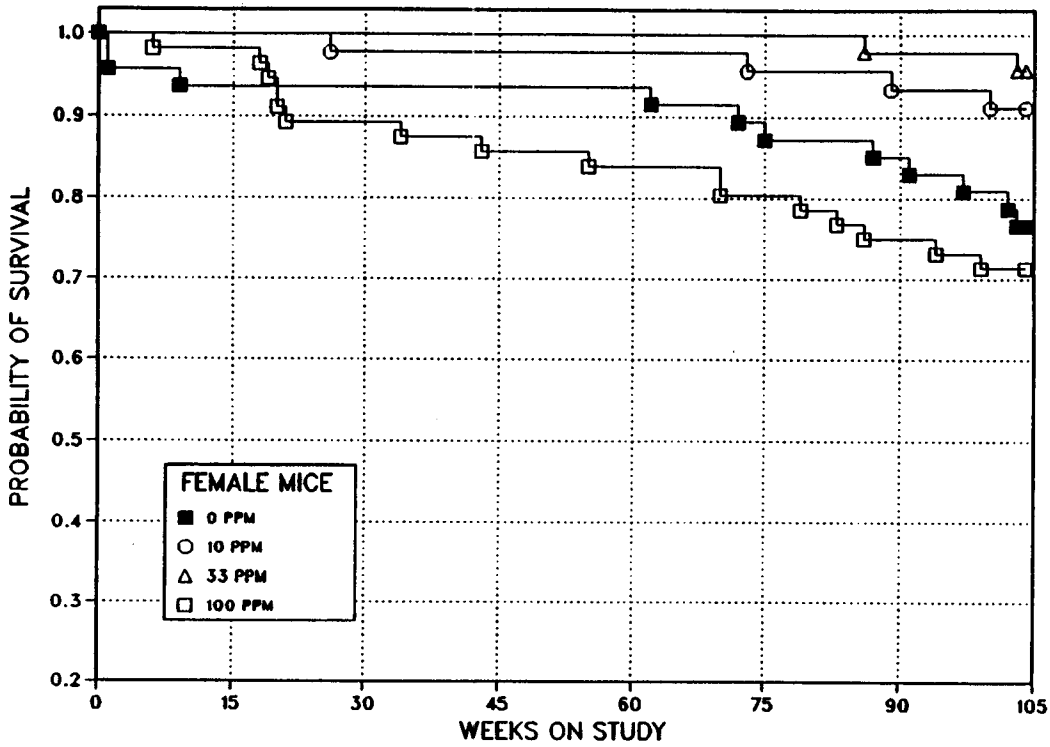
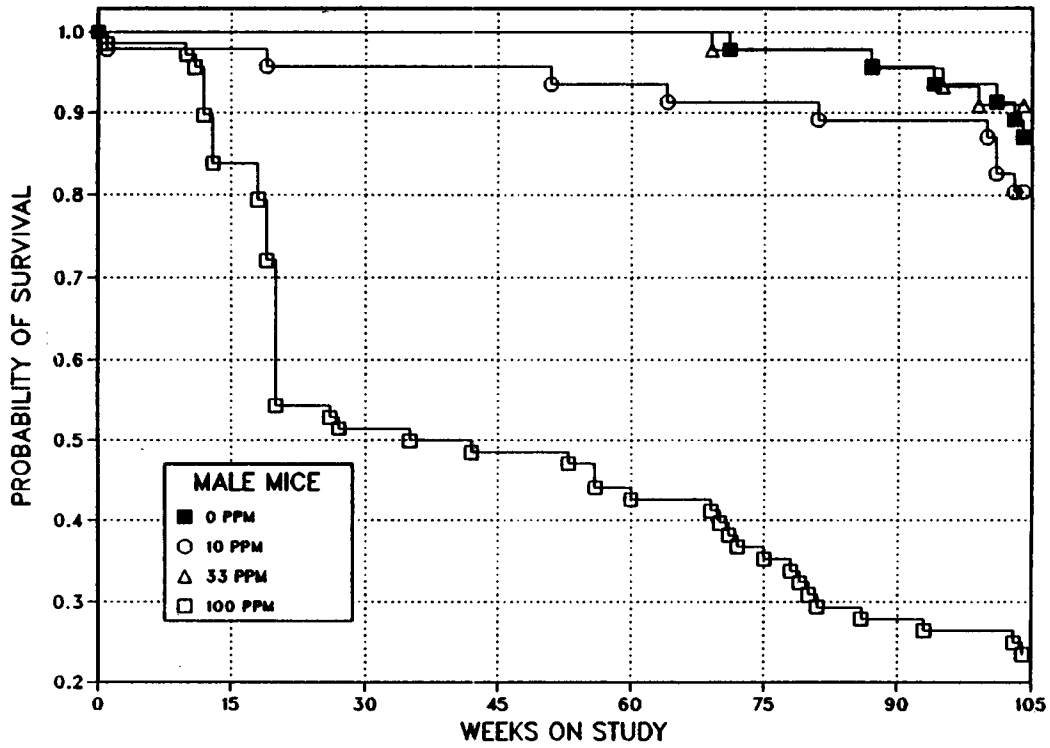

FIGURE 2
Kaplan-Meier Survival Curves for Mice in the 2-Year Inhalation Studies of Methyl Bromide

Pathology and Statistical Analyses of Results

Exposure to methyl bromide by inhalation caused no carcinogenic effects under the experimental conditions of these studies. Increased incidences of nonneoplastic lesions in the brain, heart, bone (sternum), and nose were noted in both sexes but these lesions occurred most frequently in males. Summaries of the incidences of neoplasms and nonneoplastic lesions, individual animal tumor diagnoses, and statistical analyses of primary tumors that occurred with an incidence of at least 5% in at least one animal group are presented in Appendixes A for male mice and B for female mice.

Brain: A treatment-related increased incidence of cerebellar and cerebral degeneration occurred in both sexes (Table 10). Cerebellar degeneration was characterized by focal to diffuse nuclear pyknosis of internal granular layer cells (Plates 1, 2, and 3). Purkinje cells were unaffected. Cerebral degeneration was observed in the brains of high-dose animals of both sexes; these lesions were subtle and consisted of focal, cortical neuronal necrosis, sometimes accompanied by mild neuropil edema, congestion, and gliosis. Cerebellar and cerebral degeneration occurred more frequently in animals that died early in the study; this suggested an association between

TABLE 10
Incidence of Nonneoplastic Lesions of the Brain in B6C3F₁ Mice in the 2-Year Studies of Methyl Bromide

	0 ppm	10 ppm	33 ppm	100 ppm
Males				
Cerebellar Degeneration				
Overall rates ^a	0/50 (0%)	0/50 (0%)	0/50 (0%)	31/70 (44%)
Adjusted rates ^b	0.0%	0.0%	0.0%	54.5%
Terminal rates ^c	0/40 (0%)	0/37 (0%)	0/40 (0%)	3/16 (19%)
First incidence (days)				68
Life table tests ^d	P<0.001	– ^e	–	P<0.001
Cerebral Degeneration				
Overall rates	0/50 (0%)	0/50 (0%)	0/50 (0%)	11/70 (16%)
Adjusted rates	0.0%	0.0%	0.0%	18.5%
Terminal rates	0/40 (0%)	0/37 (0%)	0/40 (0%)	0/16 (0%)
First incidence (days)				68
Life table tests	P<0.001	–	–	P=0.002
Females				
Cerebellar Degeneration				
Overall rates	0/50 (0%)	0/50 (0%)	0/50 (0%)	11/60 (18%)
Adjusted rates	0.0%	0.0%	0.0%	20.9%
Terminal rates	0/36 (0%)	0/41 (0%)	0/45 (0%)	4/40 (10%)
First incidence (days)				124
Life table tests	P<0.001	–	–	P=0.002
Cerebral Degeneration				
Overall rates	0/50 (0%)	0/50 (0%)	0/50 (0%)	2/60 (3%)
Adjusted rates	0.0%	0.0%	0.0%	3.5%
Terminal rates	0/36 (0%)	0/41 (0%)	0/45 (0%)	0/40 (0%)
First incidence (days)				138
Life table tests	P=0.055	–	–	P=0.273

^a Number of lesion-bearing animals/number of animals examined at site

^b Kaplan-Meier estimated tumor incidence at the end of the study after adjustment for intercurrent mortality

^c Observed incidence at terminal kill

^d Beneath the control (0 ppm) incidence are the P values associated with the trend test. Beneath the dosed group incidence are the P values corresponding to pairwise comparisons between the controls and that dosed group. The life table analysis regards tumors in animals dying prior to terminal kill as being (directly or indirectly) the cause of death.

^e No lesion in dosed group; statistical test not performed.

these lesions and the increased mortality observed in this group. Thus the life table test, rather than logistic regression, is the more appropriate statistical procedure for evaluating these particular lesions.

Heart: Myocardial degeneration and chronic cardiomyopathy occurred with a significant positive trend in male and female mice (Table 11). Myocardial degeneration was an acute change characterized by myofiber sarcoplasmic hyalinization and/or vacuolization and by variation in nuclear size accompanied by mild interstitial hypercellularity (Plate 4). Of the 33 high-dose males that died or were killed prior to day 200 of the study, 30 had this lesion; only 2/37 animals that died later showed myocardial degeneration.

A similar pattern of response was seen in high-dose females. Because life table analysis regards lesions in animals dying before study termination as the direct or indirect cause of death, life table analysis, rather than logistic regression tests, is appropriate for evaluating the degenerative lesions. Chronic cardiomyopathy was characterized by focal myofiber atrophy, fibrosis, and focal to diffuse mononuclear cell infiltrates (Plate 5). This lesion was not observed in the 32 high-dose male mice that died during the first 6 months of the study. This lesion occurred in 9/16 high-dose male mice survivors and in 15/22 high-dose males that died during the last one and one-half years of the study. A similar pattern of response was seen in high-dose

TABLE 11
Incidence of Nonneoplastic Lesions of the Heart in B6C3F₁ Mice in the 2-Year Studies of Methyl Bromide

	0 ppm	10 ppm	33 ppm	100 ppm
Males				
Degeneration				
Overall rates ^a	0/50 (0%)	0/50 (0%)	0/50 (0%)	32/70 (46%)
Adjusted rates ^b	0.0%	0.0%	0.0%	50.5%
Terminal rates ^c	0/40 (0%)	0/37 (0%)	0/40 (0%)	2/16 (13%)
First incidence (days)				68
Life table tests ^d	P<0.001	– ^e	–	P<0.001
Chronic Cardiomyopathy				
Overall rates	4/50 (8%)	7/50 (14%)	10/50 (20%)	24/70 (34%)
Adjusted rates	10.0%	17.4%	24.1%	75.0%
Terminal rates	4/40 (10%)	4/37 (11%)	9/40 (23%)	9/16 (56%)
First incidence (days)	728 (T)	680	570	185
Logistic regression tests	P<0.001	P=0.256	P=0.088	P<0.001
Females				
Degeneration				
Overall rates	1/50 (2%)	0/50 (0%)	0/50 (0%)	7/59 (12%)
Adjusted rates	2.8%	0.0%	0.0%	11.7%
Terminal rates	1/36 (3%)	0/41 (0%)	0/45 (0%)	0/39 (0%)
First incidence (days)	728 (T)			41
Life table tests	P<0.001	P=0.474N	P=0.455N	P=0.058
Chronic Cardiomyopathy				
Overall rates	2/50 (4%)	4/50 (8%)	2/50 (4%)	34/59 (58%)
Adjusted rates	5.1%	9.8%	4.4%	73.5%
Terminal rates	1/36 (3%)	4/41 (10%)	2/45 (4%)	27/39 (69%)
First incidence (days)	674	728 (T)	728 (T)	296
Logistic regression tests	P<0.001	P=0.308	P=0.697	P<0.001

(T)Terminal sacrifice

^a Number of lesion-bearing animals/number of animals examined at site

^b Kaplan-Meier estimated tumor incidence at the end of the study after adjustment for intercurrent mortality

^c Observed incidence at terminal kill

^d Beneath the control (0 ppm) incidence are the P values associated with the trend test. Beneath the dosed group incidence are the P values corresponding to pairwise comparisons between the controls and that dosed group. The life table analysis regards tumors in animals dying prior to terminal kill as being (directly or indirectly) the cause of death. The logistic regression tests regard these lesions as nonfatal. For all tests, a negative trend or a lower incidence in a dose group is indicated by N.

^e No lesion in dosed group; statistical test not performed.

females. The logistic regression tests regard this lesion as nonfatal and, therefore, are the more appropriate tests to evaluate the chronic cardiomyopathies. Separation of the two lesions was often difficult due to the overlap of histologic criteria. These lesions may reflect a morphologic continuum related to the temporal development of myocardial changes, with degeneration a more acute change compared to chronic cardiomyopathy.

Bone (Sternum): A dose-related increased incidence of sternal dysplasia was observed in both sexes (Table 12). Grossly, this lesion consisted of sternal distortion with ventral displacement of the manu-

brium into the thoracic inlet. The sternal dysplasia was characterized by ventral to ventrolateral deviation of the manubrium with subluxation of other sternebrae. Irregular proliferative protruberances composed of well-differentiated mature cartilage and bone were often present along the sternbral articular surfaces, causing a "lipping" effect. This lesion appeared to be an incidental lesion and not related to the cause of death. For instance, in high-dose male mice, 12/16 survivors had this lesion compared with only 2/54 animals that died during the study. Moreover, the two early deaths occurred relatively late in the study at day 564 and 723. The logistic regression tests are the more appropriate statistical procedure for evaluating this lesion.

TABLE 12
Incidence of Dysplasia of the Sternum in B6C3F₁ Mice in the 2-Year Studies of Methyl Bromide

	0 ppm	10 ppm	33 ppm	100 ppm
Males				
Overall rates ^a	0/50 (0%)	0/50 (0%)	3/50 (6%)	14/70 (20%)
Adjusted rates ^b	0.0%	0.0%	7.2%	77.5%
Terminal rates ^c	0/40 (0%)	0/37 (0%)	2/40 (5%)	12/16 (75%)
First incidence (days)			662	564
Logistic regression tests ^d	P<0.001	— ^e	P=0.119	P<0.001
Females				
Overall rates	0/50 (0%)	2/50 (4%)	2/50 (4%)	9/60 (15%)
Adjusted rates	0.0%	4.9%	4.4%	21.2%
Terminal rates	0/36 (0%)	2/41 (5%)	2/45 (4%)	7/40 (18%)
First incidence (days)		728 (T)	728 (T)	579
Logistic regression tests	P<0.001	P=0.267	P=0.289	P=0.003

(T)Terminal Sacrifice

^a Number of lesion-bearing animals/number of animals examined at site

^b Kaplan-Meier estimated tumor incidence at the end of the study after adjustment for intercurrent mortality

^c Observed incidence at terminal kill

^d Beneath the control (0 ppm) incidence are the P values associated with the trend test. Beneath the dosed group incidence are the P values corresponding to pairwise comparisons between the controls and that dosed group. The logistic regression tests regard these lesions as nonfatal.

^e No lesion in dosed group; statistical test not performed.

Nose: Treatment-related increased incidences of olfactory epithelial necrosis and metaplasia were seen in the nose of male and female mice (Table 13). Necrosis was defined as focal cell death and loss of olfactory epithelium (nerve cells and sustentacular cells) resulting in a sculptured outline of the mucosal surface (Plate 6). The occurrence of this lesion was limited to animals that died during the first 138 days of the study; one was present in

a high-dose mouse that died on day 4. The life table analysis is more appropriate for evaluating this particular lesion. Metaplasia, seen primarily in animals that survived to the end of the studies, was characterized by focal areas in which the usual olfactory epithelium was replaced by ciliated columnar epithelial cells resembling respiratory epithelium (Plates 7 and 8). Logistic regression analysis was used to evaluate this lesion.

TABLE 13
Incidence of Nonneoplastic Lesions of the Olfactory Epithelium^a in B6C3F₁ Mice in the 2-Year Studies of Methyl Bromide

	0 ppm	10 ppm	33 ppm	100 ppm
Males				
Olfactory Epithelium: Metaplasia				
Overall rates ^b	0/50 (0%)	0/50 (0%)	1/50 (2%)	2/69 (3%)
Adjusted rates ^c	0.0%	0.0%	2.5%	12.5%
Terminal rates ^d	0/40 (0%)	0/37 (0%)	1/40 (3%)	2/16 (13%)
First incidence (days)			728 (T)	728 (T)
Logistic regression tests ^e	P=0.009	– ^f	P=0.500	P=0.071
Olfactory Epithelium: Necrosis				
Overall rates	0/50 (0%)	0/50 (0%)	0/50 (0%)	6/69 (9%)
Adjusted rates	0.0%	0.0%	0.0%	9.6%
Terminal rates	0/40 (0%)	0/37 (0%)	0/40 (0%)	0/16 (0%)
First incidence (days)				4
Life table tests	P<0.001	–	–	P=0.034
Females				
Olfactory Epithelium: Metaplasia				
Overall rates	0/50 (0%)	0/50 (0%)	0/50 (0%)	5/60 (8%)
Adjusted rates	0.0%	0.0%	0.0%	12.5%
Terminal rates	0/36 (0%)	0/41 (0%)	0/45 (0%)	5/40 (13%)
First incidence (days)				728 (T)
Logistic regression tests	P<0.001	–	–	P=0.043
Olfactory Epithelium: Necrosis				
Overall rates	0/50 (0%)	0/50 (0%)	0/50 (0%)	1/60 (2%)
Adjusted rates	0.0%	0.0%	0.0%	1.7%
Terminal rates	0/36 (0%)	0/41 (0%)	0/45 (0%)	0/40 (0%)
First incidence (days)				41
Life table tests	P=0.247	–	–	P=0.536

(T)Terminal sacrifice

^a The olfactory epithelial surface includes associated cell structures; nerve and sustentacular cells

^b Number of lesion-bearing animals/number of animals examined at site

^c Kaplan-Meier estimated tumor incidence at the end of the study after adjustment for intercurrent mortality

^d Observed incidence at terminal kill

^e Beneath the control (0 ppm) incidence are the P values associated with the trend test. Beneath the dosed group incidence are the P values corresponding to pairwise comparisons between the controls and that dosed group. The life table analysis regards tumors in animals dying prior to terminal kill as being (directly or indirectly) the cause of death. The logistic regression tests regard these lesions as nonfatal.

^f No lesion in dosed group; statistical test not performed.

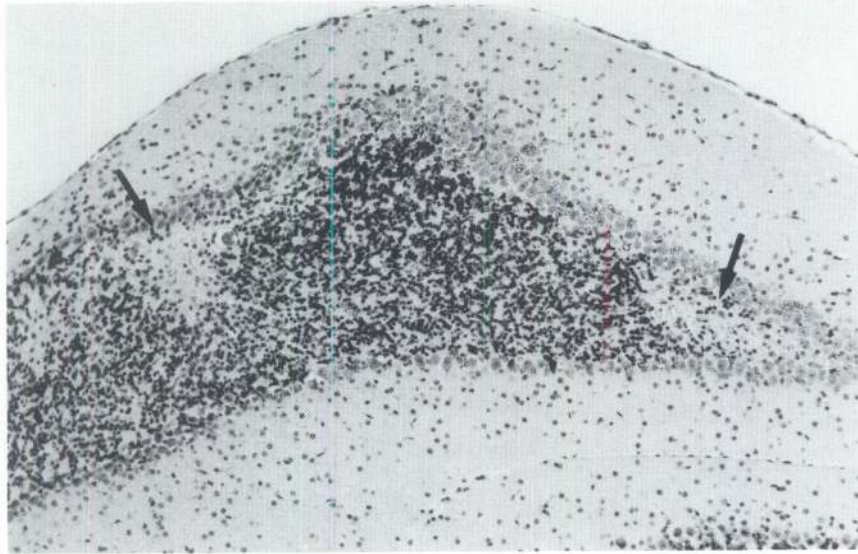

PLATE 1. Cerebellar cortex from female from the 100 ppm dose group. Focal degeneration of the internal granular cell layer (arrows) characterized by neuronal loss; compare with Plate 3. (H&E, x75).

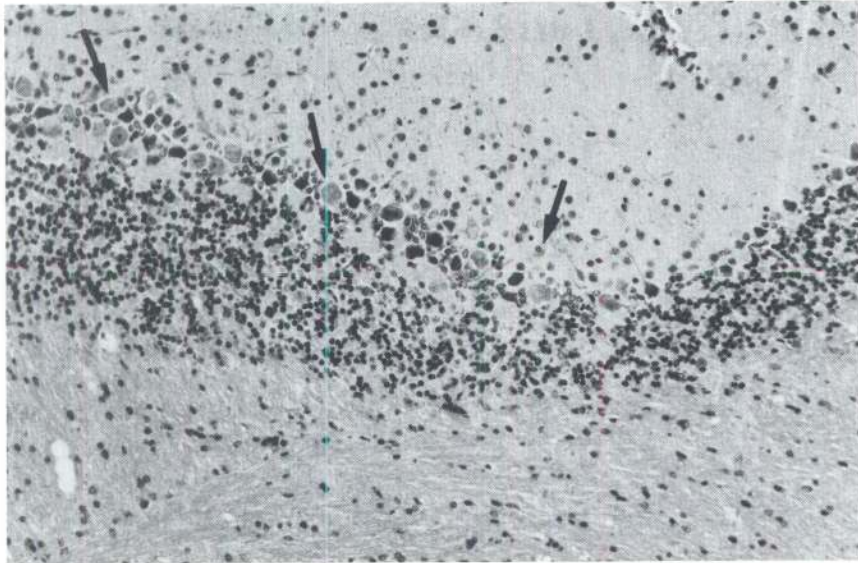

PLATE 2. Cerebellar cortex from male mouse from the 100 ppm dose group. This area of the internal granular layer is relatively depleted of cells. Purkinje cells (arrows) remain. Compare with Plate 3. (H&E, x120).

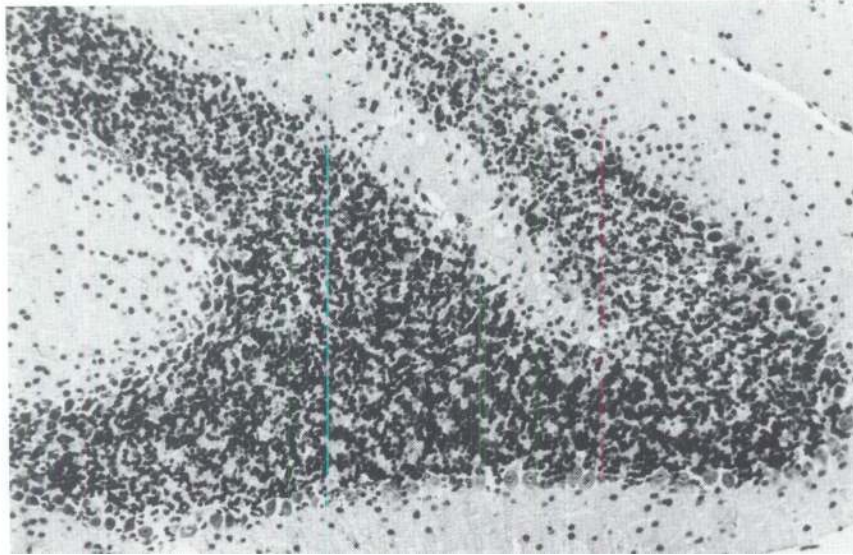

PLATE 3. Cerebellar cortex from male mouse from the 100 ppm dose group. This area of cortex is of normal morphology; compare with Plates I and 2. (H&E, x120).

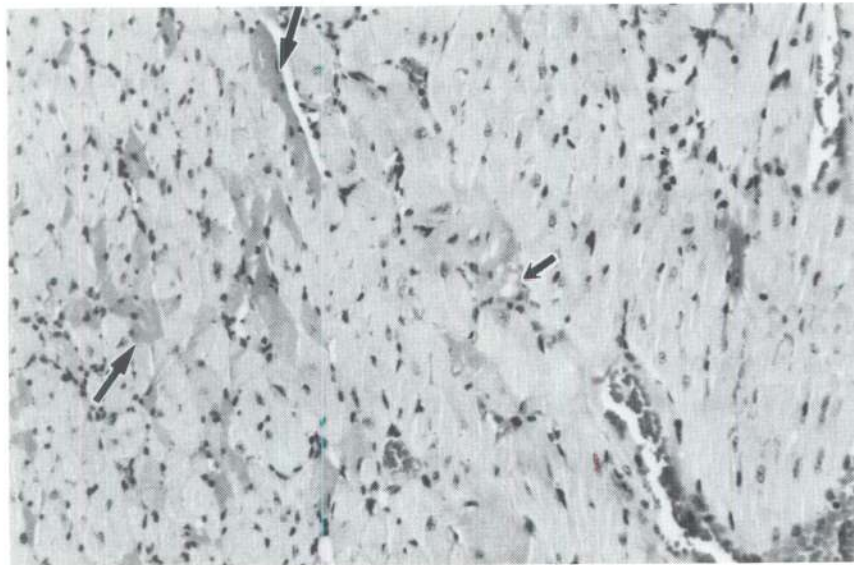

PLATE 4. Myocardium from female mouse from the 100 ppm dose group. Degeneration is characterized by myofibers with hyalinized sarcoplasm (large arrows) and/or small sarcoplasmic vacuoles (small arrow). (H&E, x150).

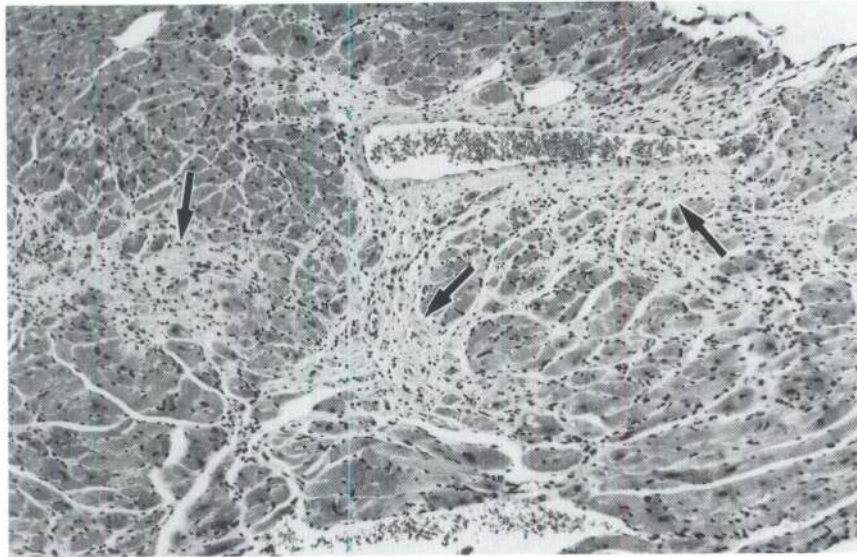

PLATE 5. Myocardium from female mouse with chronic cardiomyopathy from the 100 ppm dose group. Myofibers are focally replaced by fibrous connective tissue (arrows). (H&E, x75).

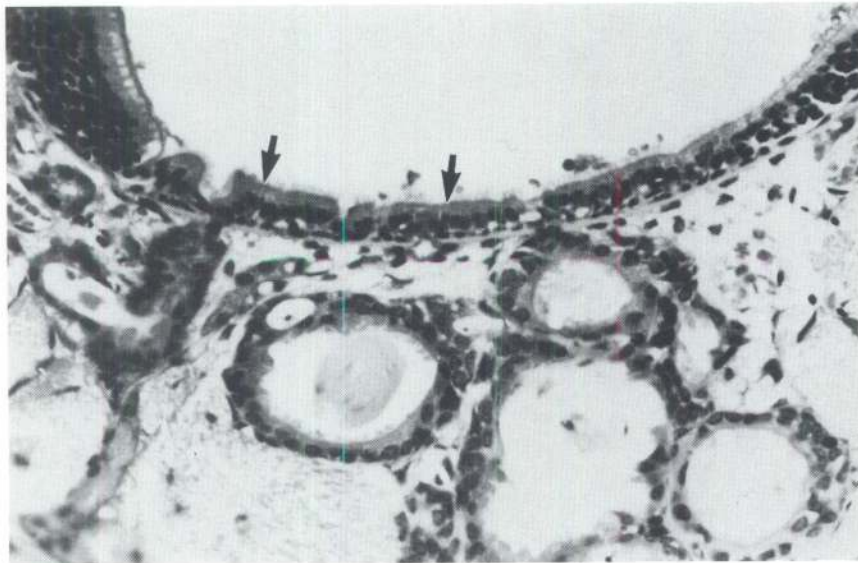

PLATE 6. Olfactory epithelium from nose of male mouse from 33 ppm dose group with focal respiratory metaplasia (arrows). Compare with Plate 8. (H&E, x200).

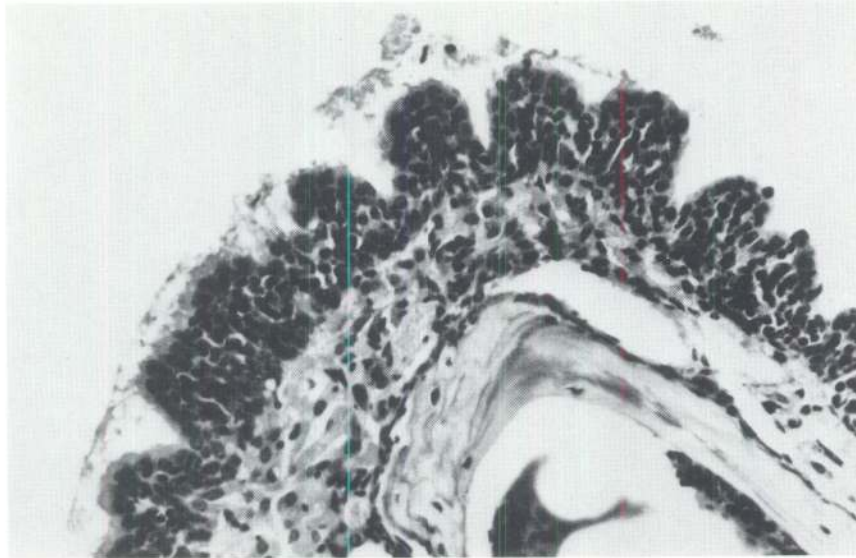

PLATE 7. Olfactory epithelium front nose of male mouse from 100 ppm dose group showing sculptured mucosal surface outline resulting from focal necrosis. Compare with Plate 8. (H&E, x300).

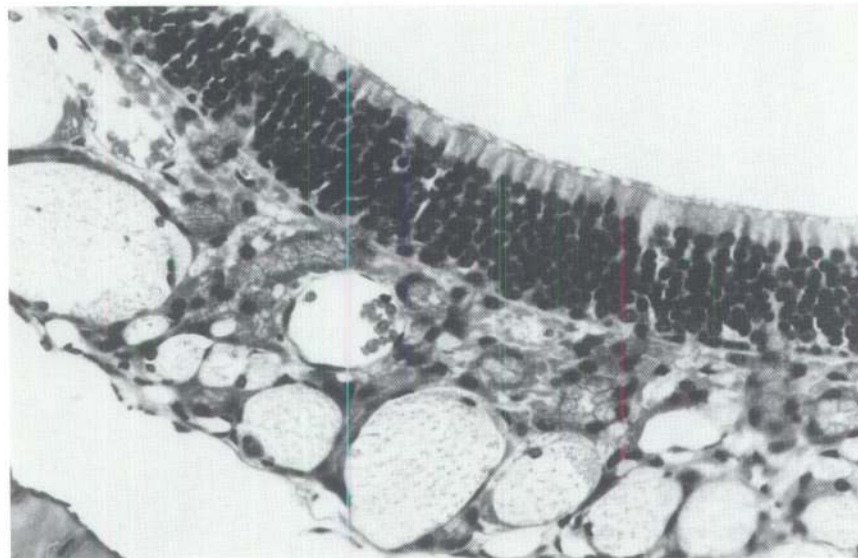

PLATE 8. Nose. Normal olfactory epithelium from male mouse from 100 ppm dose group. Note the uniform height and multiple layers of cells. (H&E, x300).

Other Organs: In male mice, increased incidences of atrophy of the spleen, atrophy and necrosis of the thymus, acute or suppurative inflammation in the nose, hepatocellular cytoplasmic vacuolization, and testicular degeneration were also observed, usually in animals which died or were sacrificed while moribund; these lesions were considered secondary to stress and weight loss rather than direct toxic effects of methyl bromide exposure.

GENETIC TOXICOLOGY

Methyl bromide, tested within a sealed desiccator to ensure adequate exposure, was mutagenic in *Salmonella typhimurium* strain TA100, with and without Aroclor 1254-induced male Sprague-Dawley rat liver or Syrian hamster liver S9; no mutagenic response was observed in strain TA98 with or without S9 (Table F1). Doses tested ranged from 0.004 to 2.4 moles per liter; slight to severe toxicity was noted at doses of 0.120 moles per liter and above.

Methyl bromide induced sister chromatid exchanges in bone marrow cells and micronuclei in peripheral erythrocytes of B6C3F₁ female mice exposed over a 14-day period for 6 hours per day, 5 days per week (Table F2). Elevated responses in the micronucleus test were obtained over the entire dose range (12 to 200 ppm), with the greatest responses seen at the two highest doses tested (100 and 200 ppm). In the

sister chromatid exchange test, a dose response was observed and an increase of two sister chromatid exchanges/cell was seen at the highest dose. In male mice exposed to methyl bromide for 14 days, a dose response was seen in the sister chromatid exchange test, although the magnitude at the highest dose (one sister chromatid exchange/cell) was less than that observed in female mice. Likewise, in the 14-day micronucleus test with male mice, small increases were noted in the 25, 50, and 100 ppm dose groups, but analysis of the response across doses indicated less significance than the response noted in females. Therefore, these test results in male mice were considered to be equivocal. Average generation time, used as a measure of bone marrow cell cycle kinetics, was unaffected in male and female mice, even at the highest dose levels tested.

Groups of male and female B6C3F₁ mice exposed to methyl bromide for a 12-week period were examined for induction of sister chromatid exchanges in bone marrow cells and of micronuclei in peripheral erythrocytes. All tests were negative. In addition, methyl bromide exposure produced no effect on bone marrow cell kinetics, as indicated by the average generation time values. The percentage of polychromatic erythrocytes in the peripheral blood was unaltered by methyl bromide exposure, indicating lack of either stimulation or suppression of erythropoiesis (Table F3).

DISCUSSION AND CONCLUSIONS

DOSE SELECTION AND DOSE RESPONSE

The steepness of the methyl bromide dose-response curve is reflected in the mortality reported in the 14-day and 13-week toxicity studies. In 14-day inhalation studies in B6C3F₁ mice, only 4/10 females and 1/10 males survived the 10 exposures at 200 ppm, but no deaths occurred in the other dose groups (12, 25, 50, or 100 ppm). Clinical observations suggested neurotoxicity in the high-dose groups. Based on these findings, the dose levels in the 13-week inhalation studies of methyl bromide in B6C3F₁ mice were set at 0, 10, 20, 40, 80, or 120 ppm. In parallel 13-week inhalation studies, F344/N rats were exposed to 0, 30, 60, or 120 ppm methyl bromide. Rats and mice were exposed 6 hours per day, 5 days per week. No mortality occurred among rats at any exposure level, but 4/24 (17%) of the male mice exposed to 120 ppm died during the 13-week studies. No female mice or male mice in the lower dose groups died. No chemical-induced histologic changes were seen in mice at any dose level; however, there was an increased incidence of dysplasia and cysts of the olfactory epithelium in high-dose male and female rats.

Because no strong evidence of specific organ toxicity was seen in the short-term studies, a special 6-week study was conducted (Appendix J). As expected, mortality was high in mice and rats exposed to 160 ppm methyl bromide. Only female rats had a mortality of less than 50% after 30 days of exposure. Organ toxicity was seen primarily in the brain, kidney, nasal cavity, heart, adrenal gland, liver, and testis. However, there were clear species- and sex-related differences in susceptibility of specific organs to methyl bromide. On the basis of these and earlier range-finding studies, the doses for the 2-year inhalation studies in B6C3F₁ mice were set at 0, 10, 33, or 100 ppm methyl bromide. When these doses were set, high mortality was not expected in the 2-year studies for two reasons. First, in the earlier, 14-day study, mice exposed to 100 ppm methyl bromide showed neither mortality nor obvious signs of toxicity. Second, there was a lack of any marked toxicologic findings in the 13-week

study animals exposed to up to 120 ppm methyl bromide. However, 20 weeks (139 days) into the 2-year studies, the mortality rates for the 100 ppm males and females reached 31% (27/86) and 8% (7/86), respectively.

As discussed in Materials and Methods, exposure of both males and females in the 100 ppm groups to methyl bromide was discontinued at week 20. Survivors were observed for signs of chronic toxicity or carcinogenicity for the remainder of the 2-year studies. Scheduled 6- and 15-month interim evaluations were not carried out in the 100 ppm males; females in the 100 ppm dose group were not evaluated at 6 months, but the 15-month interim evaluation was carried out.

Although the rapid loss of animals in the 100 ppm dose group ceased when exposure to methyl bromide was discontinued, survivors continued to exhibit clinical signs indicative of neurotoxicity, including tremors, abnormal posture, tachypnea, and hind leg paralysis, until the end of the 2-year studies.

These results illustrate that methyl bromide toxicity, particularly lethality, appears to follow a very steep dose-response curve. Further, this response may be a function of both dose and time. That is, animals may appear normal with little or no toxic signs when exposed to a certain concentration of methyl bromide, only to suffer severe mortality or other types of toxic responses with a small increase in concentration. Similarly, a longer exposure period may precipitously increase the mortality.

COMPARISON OF CHRONIC TOXICITY OF METHYL BROMIDE AND ITS STRUCTURAL ANALOGS

Inhalation toxicity studies of methyl chloride were conducted in F344/N rats and B6C3F₁ mice exposed to 0, 50, 225, or 1,000 ppm for 24 months (Pavkov *et al.*, 1982). Poor survival in mice, particularly in males, was felt to be a direct result of fighting in a group housing environment; thus mortality in mice was probably unrelated to methyl chloride exposure. The highest dose used in the methyl chloride studies

was tenfold higher than that in the current methyl bromide studies.

There is an obvious difference in chronic toxicity between these two chemicals. Methyl chloride and methyl bromide also differ in carcinogenicity; methyl chloride was found to be a renal carcinogen in B6C3F₁ mice (Pavkov *et al.*, 1982), whereas methyl bromide was not carcinogenic under the experimental conditions of the present studies. Similarly, the Dutch chronic inhalation studies showed no evidence of carcinogenicity in Wistar rats exposed to up to 90 ppm methyl bromide for 29 months (Reuzel *et al.*, 1987). Methyl chloride-induced renal tumors in mice included cortical adenoma, cortical adenocarcinoma, papillary cystadenoma, papillary cystadenocarcinoma, and tubular cystadenoma (Pavkov *et al.*, 1982). Although these tumors were prevalent in the mice treated with 1,000 ppm methyl chloride, renal neoplasms were also seen in two 225 ppm male mice at the 24-month sacrifice. No evidence of carcinogenicity was seen in rats in these studies. However, one similarity in target organ toxicity following chronic exposure to methyl chloride and methyl bromide is the presence of degenerative changes in the brains of mice exposed to higher concentrations of either chemical. Comparisons of neoplastic and nonneoplastic chronic toxicities of methyl chloride and methyl bromide are summarized in Table 14.

The cause of the differences in toxicity between methyl chloride and methyl bromide in B6C3F₁ mice is unknown. The mechanism of toxicity may be the direct methylation or methanethiol formation via the glutathione conjugation pathway for both chemicals, and since bromine is a better leaving group than chlorine, methyl bromide would be a more reactive methylating agent. Thus, depending on the pharmacokinetics in the animal under the specific exposure conditions, some differences in toxicity to methyl bromide and methyl chloride may result. If, however, the mechanisms of toxicity of the structural analogs are not identical, this alone would account for different toxicities.

Chronic toxicity and carcinogenicity of ethyl bromide and ethyl chloride, two other structural analogs of methyl bromide, were evaluated by the NTP (NTP, 1989a,b). Both chemicals were studied via inhalation exposure to F344/N rats and B6C3F₁ mice for two years. Exposure concentrations were 0, 100,

200, or 400 ppm for ethyl bromide and 0 or 15,000 ppm for ethyl chloride. Evidence of carcinogenicity was seen for both ethyl bromide and ethyl chloride under the experimental conditions; there was clear evidence of carcinogenicity for both chemicals in female mice based on increased incidences of uterine neoplasms. Table 14 compares the chronic toxicity of methyl bromide, ethyl bromide, methyl chloride, and ethyl chloride. The causes of the differences in toxicity between methyl bromide and these chemical analogs remain to be explored.

MECHANISTIC HYPOTHESES

The mechanism of toxicity of methyl bromide is still unclear, although there are several hypotheses. The earliest hypothesis speculated that mortality was related to bromide ion concentrations in the animal (Miller and Haggard, 1943). These investigators further indicated that a larger proportion of the bromide ion was located intracellularly following methyl bromide administration compared with that following the administration of sodium bromide. They thus launched the hypothesis of "intracellular brominism" as the mechanism of toxicity for methyl bromide. This suggestion has been judged improbable in other publications (Irish *et al.*, 1941; Clarke *et al.*, 1945; Collins, 1965; Nishimura *et al.*, 1980; Honma *et al.*, 1985). The possibility that methanol, a metabolite in methyl bromide biotransformation, acts as the intoxicating agent was also suggested; however, methanol is less toxic than methyl bromide, and the two chemicals have entirely different clinical signs of toxicity (Alexeeff and Kilgore, 1983).

More likely, the mechanism of methyl bromide toxicity relates to the alkylating ability of methyl bromide. Perhaps because of its chemical reactivity, methyl bromide alkylates a variety of functional groups of many amino acids, including sulfhydryl and amino groups (Blackburn *et al.*, 1941; Blackburn and Phillips, 1944; Lewis, 1948; Winteringham, 1955; Winteringham and Barnes, 1955; Dunkelburg, 1980; Djalali-Behzad *et al.*, 1981). According to the alkylation hypothesis, there are two possible mechanisms of methyl bromide toxicity: (1) direct methylation of critical biological molecules by methyl bromide leading to toxicity; and (2) after initial methylation of endogenous molecules, reactive metabolites form the true toxic agents.

A s i n d i c a t e d

TABLE 14
Comparison of Chronic Toxicity and Carcinogenicity Caused by Methyl Bromide, Ethyl Bromide, Methyl Chloride, and Ethyl Chloride

Organ-Lesion	Methyl Bromide ^a	Ethyl Bromide ^b	Methyl Chloride ^c	Ethyl Chloride ^d
Adrenal Medulla Pheochromocytomas	none	male rats	none	none
Brain Cerebellar Degeneration Cerebral Degeneration	mice	none	mice	none
Bone - Sternum Dysplasia	mice	none	none	none
Heart Degeneration Chronic cardiomyopathy	mice	none	none	none
Kidney Tubuloepithelial hyperplasia Karyomegaly Cortical cysts Cortical adenoma Cortical adenocarcinoma Papillary cystadenoma Papillary cystadenocarcinoma Tubular cystadenoma	none	none	mice	none
Liver Hepatocellular vacuolization Karyomegaly Cytomegaly Multinucleated hepatocytes Degeneration	none	none	mice	none
Nose - Nasal Cavity Epithelial hyperplasia Squamous metaplasia Suppurative inflammation	none	rats	none	none
Nose - Olfactory Epithelium Metaplasia Necrosis	mice	rats ^e	none	none
Spleen Lymphoid depletion Atrophy	none	none	mice	none
Testis Seminiferous tubules, bilateral, diffuse degeneration Atrophy	none	none	rats	none
Uterus Adenomas Adenocarcinomas Squamous cell carcinomas	none	female mice	none	female mice

- ^a This study
^b NTP, 1989a
^c Pavkov, 1981
^d NTP, 1989b
^e Metaplasia only

by Alexeeff and Kilgore (1983), the greatest difficulty with the first possibility is the lack of substrate specificity of methyl bromide. Regarding the second possibility, studies from several laboratories suggest that methyl halides are metabolized by reaction with glutathione (Barnsley and Young, 1965; Johnson, 1966; Kornbrust and Bus, 1983). In addition, the acute effects of methyl chloride toxicity in male B6C3F₁ mice are inhibited by glutathione depletion before exposure (Chellman *et al.*, 1986). Kornbrust and Bus (1983) further suggested that the neurotoxic effects and possibly the hepatic and renal toxicity of methyl chloride may be due to the formation of methanethiol in the glutathione metabolic pathway. Similar patterns in the uptake, disposition, metabolism, and excretion of methyl bromide and methyl chloride are likely to account for many of the similarities in the tissues affected and types of lesions observed.

Although the hypothesis proposing the formation of a reactive species (i.e., methanethiol) through a methyl bromide-glutathione conjugation process appeared promising, there are reports providing experimental evidence that may be considered inconsistent with such a toxic mechanism. For instance, in a study by Mizyubova and Bakhishev (1971), rats were injected with cysteine 5 minutes after exposure to a lethal dose of methyl bromide; clinical signs and mortality of the animals were reduced. Similarly, the addition of glutathione to cell cultures reduced the toxicity of methyl bromide (Nishimura *et al.*, 1980). These reports suggest that cysteine and glutathione served as detoxifying agents rather than as precursors for an intoxication process. Thus the most likely mechanism of toxicity for methyl bromide is still related to the methylation reactivity of the methyl bromide molecule *per se*. The acute toxicity, including lethality, of methyl bromide is probably induced by a general or

nonspecific methylation of important tissues and molecules, whereas the long-term toxicity following repeated exposure may be mediated through the glutathione conjugation pathway to form reactive species, which in turn react with specific target tissues *in situ*.

Methyl bromide is clearly genotoxic *in vitro* and *in vivo* as evidenced by the positive responses obtained in *Salmonella* (Moriya *et al.*, 1983; Kramers *et al.*, 1985) and *Drosophila* (Kramers *et al.*, 1985) gene mutation assays, the sister chromatid exchange test with human peripheral lymphocytes (Tucker *et al.*, 1986), and the tests for induction of sister chromatid exchanges and micronuclei in female mice exposed for 2 weeks to methyl bromide by inhalation (Appendix F). The *in vivo* sister chromatid exchange and micronuclei data are intriguing in that a difference in effect between male and female mice is apparent in the 2-week exposure studies, and the responses obtained in the 12-week exposure studies were negative for both endpoints in both sexes. One possible explanation is that the decrease in responses that was observed with increasing exposure duration is due to metabolic alterations or changes in bone marrow sensitivity. No significant changes in bone marrow cell kinetics (average generation time) were observed with either treatment duration.

Conclusions: Under the conditions of these 2-year inhalation studies, methyl bromide caused degenerative changes in the cerebellum and cerebrum, myocardial degeneration and cardiomyopathy, sternal dysplasia, and olfactory epithelial necrosis and metaplasia. Toxic effects persisted although exposure to methyl bromide in the 100 ppm group terminated after 20 weeks. There was *no evidence of carcinogenic activity** of methyl bromide in male or female B6C3F₁ mice exposed to 10, 33, or 100 ppm.

*Explanation of Levels of Evidence of Carcinogenic Activity is on page 8. A summary of peer review comments and the public discussion on this Technical Report appears on page 10.

REFERENCES

- Alexeeff, G.V., and Kilgore, W.W. (1983). Methyl bromide. *Residue Rev.* **88**, 101-153.
- American Conference of Governmental Industrial Hygienists (ACGIH) (1980). Documentation of the Threshold Limit Values, 4th ed., pp. 410-411. Cincinnati, OH.
- Anger, W.K., Setzer, J.V., Russo, J.M., Brightwell, W.S., Wait, R.G., and Johnson, B.L. (1981). Neurobehavioral effects of methyl bromide inhalation exposures. *Scand. J. Work Environ. Health* **7** (Suppl. 4), 40-47.
- Armitage, P. (1971). *Statistical Methods in Medical Research*, pp. 362-365. John Wiley and Sons, New York.
- Barber, E.D., Donish, W.H., and Mueller, K.R. (1981). A procedure for the quantitative measurement of the mutagenicity of volatile liquids in the Ames *Salmonella*/microsome assay. *Mutat. Res.* **90**, 31-48.
- Barnsley, E.A., and Young, L. (1965). Biochemical studies of toxic agents: The metabolism of iodomethane. *Biochem. J.* **95**, 77-81.
- Blackburn, S., Carter, E.G.H., and Phillips, H. (1941). The methylation of wool with methyl sulphate and methyl halides. *Biochem. J.* **35**, 627-639.
- Blackburn, S., and Phillips, H. (1944). Experiments on the methylation and acetylation of wool, silk fibroin, collagen and gelatin. *Biochem. J.* **38**, 171-178.
- Bond, J.A., Dutcher, J.S., Medinsky, M.A., Henderson, R.F., and Birnbaum, L.S. (1985). Disposition of [¹⁴C]methyl bromide in rats after inhalation. *Toxicol. Appl. Pharmacol.* **78**, 259-267.
- Boorman, G.A., Montgomery, C.A., Jr., Eustis, S.L., Wolfe, M.J., McConnell, E.E., and Hardisty, J.F. (1985). Quality assurance in pathology for rodent carcinogenicity studies. In *Handbook of Carcinogen Testing* (H.A. Milman and E.K. Weisburger, Eds.), pp. 345-357. Noyes Publications, Park Ridge, NJ.
- Boorman, G.A., Hong, H.L., Jameson, C.W., Yoshitomi, K., and Maronpot, R.R. (1986). Regression of methyl bromide-induced forestomach lesions in the rat. *Toxicol. Appl. Pharmacol.* **86**, 131-139.
- Burek, J.D., Nitschke, K.D., Bell, T.J., Wackerie, D.L., Childs, R.C., Beyer, J.E., Dittenber, D.A., Rampy, L.W., and McKenna, M.J. (1984). Methylene chloride: A two-year inhalation toxicity and oncogenicity study in rats and hamsters. *Fundam. Appl. Toxicol.* **4**, 30-47.
- Chellman, G.J., Bus, J.S., and Working, P.K. (1986). Role of epididymal inflammation in the induction of dominant lethal mutations in Fischer 344 rat sperm by methyl chloride. *Proc. Natl. Acad. Sci. USA* **83**, 8087-8091.
- Clarke, C.A., Roworth, C.G., Holling, H.E. (1945). Methyl bromide poisoning. *Brit. J. Ind. Med.* **2**, 17-23.
- Code of Federal Regulations (CFR), **21**, part. 58.
- Collins, R.P. (1965). Methyl bromide poisoning. A bizarre neurological disorder. *Calif. Med.* **103**, 112-116.
- Cox, D.R. (1972). Regression models and life tables. *J. R. Stat. Soc.* **B34**, 187-220.
- Craver, C.D., Ed. (1977). Spectrum No. 8828. *The Infrared Spectra of Halogenated Hydrocarbons*, p. 103. The Coblenz Society, Inc., Kirkwood, MO.
- Danse, L.H.J.C., van Velsen, F.L., and van der Heijden, C.A. (1984). Methylbromide: Carcinogenic effects in the rat forestomach. *Toxicol. Appl. Pharmacol.* **72**, 262-271.

- De Flora, S. (1981). Study of 106 organic and inorganic compounds in the *Salmonella*/microsome test. *Carcinogenesis* **2**, 283-298.
- DeKergommeaux, D.J., Grant, W.F., and Sandhu, S.S. (1983). Clastogenic and physiological response of chromosomes to nine pesticides in the *Vicia faba in vivo* root tip assay system. *Mutat. Res.* **124**, 69-84.
- Dinse, G.E., and Haseman, J.K. (1986). Logistic regression analysis of incidental-tumor data from animal carcinogenicity experiments. *Fundam. Appl. Toxicol.* **6**, 44-52.
- Dinse, G.E., and Lagakos, S.W. (1983). Regression analysis of tumor prevalence data. *Appl. Statist.* **32**, 236-248.
- Djalali-Behzad, G., Hussain, S., Osterman-Golkar, S., and Segerbäck, D. (1981). Estimation of genetic risks of alkylating agents. VI. Exposure of mice and bacteria to methyl bromide. *Mutat. Res.* **84**, 1-9.
- Dunkelberg, H. (1980). Zur Problematik der Anwendung alkylierender Substanzen bei der Lebensmittelbegasung hinsichtlich der Bildung von Vorstufen der N-Nitrosoverbindungen. II. N-Methylierung verschiedener Aminosäuren durch Einwirkung von Methylbromid. *Zbl. Bakt. Hyg., I. Abt., Orig. B* **171**, 48-54.
- Dunn, O.J. (1964). Multiple comparisons using rank sums. *Technometrics* **6**, 241-252.
- Ehrenberg, L., Osterman-Golkar, S., Singh, D., and Lundqvist, U. (1974). On the reaction kinetics and mutagenic activity of methylating and β -halogenoethylating gasoline additives. *Radiat. Bot.* **15**, 185-194.
- Eustis, S.L., Haber, S.B., Drew, R.T., and Yang, R.S.H. (1988). Toxicology and pathology of methyl bromide in F344 rats and B6C3F1 mice following repeated inhalation exposure. *Fundam. Appl. Toxicol.* **11**, 594-610.
- Florin, I., Rutberg, L., Curvall, M., and Enzell, C.R. (1980). Screening of tobacco smoke constituents for mutagenicity using the Ames' test. *Toxicology* **15**, 219-232.
- Fostel, J., Allen, P.F., Bermudez, E., Kligerman, A.D., Wilmer, J.L., and Skopek, T.R. (1985). Assessment of the genotoxic effects of methyl chloride in human lymphoblasts. *Mutat. Res.* **155**, 75-81.
- Gargas, M.L., and Andersen, M.E. (1982). Metabolism of inhaled brominated hydrocarbons: Validation of gas uptake results by determination of a stable metabolite. *Toxicol. Appl. Pharmacol.* **66**, 55-68.
- Gart, J.J., Chu, K.C., and Tarone, R.E. (1979). Statistical issues in interpretation of chronic bioassay tests for carcinogenicity. *J. Natl. Cancer Inst.* **62**, 957-974.
- Gocke, E., King, M.-T., Eckhardt, K., and Wild, D. (1981). Mutagenicity of cosmetics ingredients licensed by the European communities. *Mutat. Res.* **90**, 91-109.
- Goldmacher, V.S., and Thilly, W.G. (1983). Formaldehyde is mutagenic for cultured human cells. *Mutat. Res.* **116**, 417-422.
- Haseman, J.K. (1984). Statistical issues in the design, analysis and interpretation of animal carcinogenicity studies. *Environ. Health Perspect.* **58**, 385-392.
- Haseman, J.K., Huff, J., and Boorman, G.A. (1984). Use of historical control data in carcinogenicity studies in rodents. *Toxicol. Pathol.* **12**, 126-135.
- Haseman, J.K., Huff, J.E., Rao, G.N., Arnold, J.E., Boorman, G.A., and McConnell, E.E. (1985). Neoplasms observed in untreated and corn oil gavage control groups of F344/N rats and (C57BL/6N \times C3H/HeN)F₁ (B6C3F₁) mice. *JNCI* **75**, 975-984.
- Hezemans-Boer, M., Toonstra, J., Meulenbelt, J., Zwaveling, J-H., Sangster, B., and van Vloten, W.A. (1988). Skin lesions due to exposure to methyl bromide. *Arch. Dermatol.* **124**, 917-921.
- Honma, T., Sudo, A., Miyagawa, M., Sato, M., and Hasegawa, H. (1982). Significant changes in monoamines in rat brain induced by exposure to methyl bromide. *Neurobehav. Toxicol. Teratol.* **4**, 521-524.

- Honma, T., Sudo, A., Miyagawa, M., Sato, M., and Hasegawa, H. (1983). Changes in free amino acid contents of rat brain induced by exposure to methyl bromide. *Toxicol. Lett.* **15**, 317-321.
- Honma, T., Miyagawa, M., Sato, M., and Hasegawa, H. (1985). Neurotoxicity and metabolism of methyl bromide in rats. *Toxicol. Appl. Pharmacol.* **81**, 183-191.
- Hurtt, M.E., and Working, P.K. (1988). Evaluation of spermatogenesis and sperm quality in the rat following acute inhalation exposure to methyl bromide. *Fundam. Appl. Toxicol.* **10**, 490-498.
- Hurtt, M.E., Morgan, K.T., and Working, P.K. (1987). Histopathology of acute toxic responses in selected tissues from rats exposed by inhalation to methyl bromide. *Fundam. Appl. Toxicol.* **9**, 352-365.
- Hurtt, M.E., Thomas, D.A., Working, P.K., Monticello, T.M., and Morgan, K.T. (1988). Degeneration and regeneration of the olfactory epithelium following inhalation exposure to methyl bromide: Pathology, cell kinetics, and olfactory function. *Toxicol. Appl. Pharmacol.* **94**, 311-328.
- Ikawa, N., Araki, A., Nozake, K., and Matsushima, T. (1986). Micronucleus test of methyl bromide by the inhalation method. *Mutat. Res.* **164**, 269. (Abstr.)
- Irish, D.D., Adams, E.M., Spencer, H.C., and Rowe, V.K. (1940). The response attending exposure of laboratory animals to vapors of methyl bromide. *J. Ind. Hyg. Toxicol.* **22**, 218-230.
- Irish, D.D., Adams, E.M., Spencer, H.C., and Rowe, V.K. (1941). Chemical changes of methyl bromide in the animal body in relation to its physiological effects. *J. Ind. Hyg. Toxicol.* **23**, 408-411.
- Jackman, L.M., and Sternhell, S. (1969). *Applications of Nuclear Magnetic Resonance Spectroscopy in Organic Chemistry*, 2nd ed., p. 167. Pergamon Press, New York.
- Jaskot, R.H., Grose, E.C., Most, B.M., Menache, M.G., Williams, T.B., and Roycroft, J.H. (1988). The distribution and toxicological effects of inhaled methyl bromide in the rat. *J. Am. Coll. Toxicol.* **7**, 631-642.
- Johnson, M.K. (1966). Studies on glutathione S-alkyltransferase of the rat. *Biochem. J.* **98**, 44-56.
- Jonckheere, A. (1954). A distribution-free k-sample test against ordered alternatives. *Biometrika* **41**, 133-145.
- Kaplan, E.L., and Meier, P. (1958). Nonparametric estimation of incomplete observations. *J. Am. Stat. Assoc.* **53**, 457-481.
- Kornbrust, D.J., and Bus, J.S. (1982). Metabolism of methyl chloride to formate in rats. *Toxicol. Appl. Pharmacol.* **65**, 135-143.
- Kornbrust, D.J., and Bus, J.S. (1983). The role of glutathione and cytochrome P-450 in the metabolism of methyl chloride. *Toxicol. Appl. Pharmacol.* **67**, 246-256.
- Kowbel, D.J., Nestmann, E.R., Malaiyandi, M., and Helleur, R. (1982). Determination of mutagenic activity in *Salmonella* of residual fulvic acids after ozonation. *Water Res.* **16**, 1537-1538.
- Kramers, P.G.N., Voogd, C.E., Knaap, A.G.A.C., and van der Heijden, C.A. (1985). Mutagenicity of methyl bromide in a series of short-term tests. *Mutat. Res.* **155**, 41-47.
- Lasne, C., Gu, Z.W., Venegas, W., and Chouroulinkov, I. (1984). The *in vitro* micronucleus assay for detection of cytogenetic effects induced by mutagen-carcinogens: Comparison with the *in vitro* sister-chromatid exchange assay. *Mutat. Res.* **130**, 273-282.
- Leopold, W.R., Miller, J.A., and Miller, E.C. (1982). Comparison of some carcinogenic, mutagenic, and biochemical properties of S-vinylhomocysteine and ethionine. *Cancer Res.* **42**, 4364-4374.
- Lewis, S.E. (1948). Inhibition of SH enzymes by methyl bromide. *Nature* **161**, 692-693.
- Lund, P.M., and Cox, B.S. (1981). Reversion analysis of (*psi*) mutations in *Saccharomyces cerevisiae*. *Genet. Res.* **37**, 173-182.
- MacGregor, J.T., Wehr, C.M., and Langlois, R.G. (1983). A simple fluorescent staining procedure for micronuclei and RNA in erythrocytes using Hoechst 33258 and pyronin Y. *Mutat. Res.* **120**, 269-275.

- Maddy, K.T., Edmiston, S., and Richmond, D. (1990). Illness, injuries, and deaths from pesticide exposures in California 1949-1988. *Rev. Environ. Contam. Toxicol.* **114**, 57-123.
- Mailman, R.B. (1988). Methyl bromide. In *Dictionary of Toxicology* (E. Hodgson, R.B. Mailman, and J.E. Chambers, Eds.) p. 239. Van Nostrand Reinhold Company, New York.
- Maronpot, R.R., and Boorman, G.A. (1982). Interpretation of rodent hepatocellular proliferative alterations and hepatocellular tumors in chemical safety assessment. *Toxicol. Pathol.* **10**, 71-80.
- McConnell, E.E., Solleveld, H.A., Swenberg, J.A., and Boorman, G.A. (1986). Guidelines for combining neoplasms for evaluation of rodent carcinogenesis studies. *JNCI* **76**, 283-289.
- McFee, A.F., Lowe, K.W., and San Sebastian, J.R. (1983). Improved sister-chromatid differentiation using paraffin-coated bromodeoxyuridine tablets in mice. *Mutat. Res.* **119**, 83-88.
- McGregor, D.B. (1981). Tier II Mutagenic Screening of 13 NIOSH Priority Compounds, Individual Compound Report: Methyl Bromide. Report Number 32. National Institute of Occupational Safety and Health. Cincinnati, OH.
- McKnight, B., and Crowley, J. (1984). Tests for differences in tumor incidence based on animal carcinogenesis experiments. *J. Am. Stat. Assoc.* **79**, 639-648.
- Medinsky, M.A., Dutcher, J.S., Bond, J.A., Henderson, R.F., Mauderly, J.L., Snipes, M.B., Mewhinney, J.A., Cheng, Y.S., and Birnbaum, L.S. (1985). Uptake and excretion of [¹⁴C]methyl bromide as influenced by exposure concentration. *Toxicol. Appl. Pharmacol.* **78**, 215-225.
- The Merck Index* (1983). 10th ed., (M. Windholz, Ed.), p. 865. Merck & Company, Rahway, NJ
- Miller, D.P., and Haggard, H.W. (1943). Intracellular penetration of bromide as a feature in the toxicity of alkyl bromides. *J. Ind. Hyg. Toxicol.* **25**, 423-433.
- Miyagawa, M. (1982). Conditioned taste aversion induced by inhalation exposure to methyl bromide in rats. *Toxicol. Lett.* **10**, 411-416.
- Mizyubova, I.G., and Bakhishev, C.N. (1971). Specific treatment of acute poisoning with methyl bromide. Original in Russian, translated by NIOSH 073087 Vrach Delo 7 (1971), 128-131.
- Moriya, M., Ohta, T., Watanabe, K., Miyazawa, T., Kato, K., and Shirasu, Y. (1983). Further mutagenicity studies on pesticides in bacterial reversion assay systems. *Mutat. Res.* **116**, 185-216.
- National Cancer Institute (NCI) (1976). Guidelines for Carcinogen Bioassay in Small Rodents. Technical Report Series No. 1. NIH Publication No. 76-801. National Institutes of Health, Bethesda, MD.
- National Institute for Occupational Safety and Health (NIOSH) (1980). Registry of Toxic Effects of Chemical Substances. U.S. Department of Health, Education, and Welfare, Public Health Service, Centers for Disease Control, NIOSH.
- National Institute for Occupational Safety and Health (NIOSH) (1984). Monohalomethanes. *Current Intelligence Bulletin.* **43**, September 27.
- National Institute for Occupational Safety and Health (NIOSH) (1990). National Occupational Exposure Survey (1981-1983), unpublished provisional data as of July 1, 1990. NIOSH, Cincinnati, OH.
- National Institutes of Health (NIH) (1978). Open Formula Rat and Mouse Ration (NIH-07). Specification NIH-11-1335. U.S. Department of Health, Education, and Welfare, Public Health Service, National Institutes of Health, Bethesda, MD.
- National Toxicology Program (NTP) (1989a). Toxicology and Carcinogenesis Studies of Bromoethane (Ethyl Bromide) (CAS No. 74-96-4) in F344/N Rats and B6C3F₁ Mice (Inhalation Studies). NTP TR No. 363. NIH Publication No. 90-2818. U.S. Department of Health and Human Services, Public Health Service, National Institutes of Health, Research Triangle Park, NC.

- National Toxicology Program (NTP) (1989b). Toxicology and Carcinogenesis Studies of Chloroethane (Ethyl Chloride) (CAS No. 75-00-3) in F344/N Rats and B6C3F₁ Mice (Inhalation Studies) NTP TR No. 346. NIH Publication No. 90-2801. U.S. Department of Health and Human Services, Public Health Service, National Institutes of Health, Research Triangle Park, NC.
- Nishimura, M., Umeda, M., Ishizu, S., and Sato, M. (1980). Effect of methyl bromide on cultured mammalian cells. *J. Toxicol. Sci.* **5**, 321-330.
- Obe, G., and Ristow, H. (1977). Acetaldehyde, but not ethanol, induces sister chromatid exchanges in Chinese hamster cells *in vitro*. *Mutat. Res.* **56**, 211-213.
- Oya, Y., Yamamoto, K., and Tonomura, A. (1986). The biological activity of hydrogen peroxide. I. Induction of chromosome-type aberrations susceptible to inhibition by scavengers of hydroxyl radicals in human embryonic fibroblasts. *Mutat. Res.* **172**, 245-253.
- Pavkov, K.L. (1981). Final report on a chronic inhalation toxicology study in rats and mice exposed to methyl chloride. Battelle Columbus Laboratories Report to Chemical Industry Institute of Toxicology, December 31, 1981.
- Pavkov, K.L., Kems, W.D., Chrisp, C.E., Thake, D.C., Persing, R.L., Harroff, H.H., and Gralla, E.J. (1982). Major findings in a twenty-four month inhalation toxicity study of methyl chloride in mice and rats. *The Toxicologist*, Volume **2**, No. 1, p. 161. (Abstr.)
- Pestic. Toxicol. Chem. News* (1984). No evidence of methyl bromide carcinogenicity found by NTP panel. **13**, 9-10.
- Reuzel, P.G.J., Kuper, C.F., Dreef-van der Meulen, and Hollanders, V.M.H. (1987). Chronic (29-month) inhalation toxicity and carcinogenicity study of methyl bromide in rats. Report No. V86.469/221044, Civo Institutes TNO, Netherlands.
- Russell, L.B. and Montgomery, C.S. (1980). Use of the mouse spot test to investigate the mutagenic potential of triclosan (Irgasan DP300). *Mutat. Res.* **79**, 7-12.
- Russo, J.M., Anger, W.K., Setzer, J.V., and Brightwell, W.S. (1984). Neurobehavioral assessment of chronic low-level methyl bromide exposure in the rabbit. *J. Toxicol. Environ. Health* **14**, 247-255.
- Schmid, W. (1976). The micronucleus test for cytogenetic analysis. In *Chemical Mutagens, Principles and Methods for their Detection* (A. Hollaender, Ed.) Vol. 4, pp. 31-53. Plenum Press, New York.
- Sheldon, T., Richardson, C.R., and Elliott, B.M. (1987). Inactivity of methylene chloride in the mouse bone marrow micronucleus assay. *Mutagenesis* **2**, 57-59.
- Shimizu, H., Suzuki, Y., Takemura, N., Goto, S., and Matsushita, H. (1985). The results of microbial mutation test for forty-three industrial chemicals. *Sangyo Igaku (Japanese Journal of Industrial Health)* **27**, 400-419.
- Shirley, E. (1977). A non-parametric equivalent of Williams' test for contrasting increasing dose levels of a treatment. *Biometrics* **33**, 386-389.
- Simmon, V.F., Kauhanen, K., and Tardiff, R.G. (1977). Mutagenic activity of chemicals identified in drinking water. *Dev. Toxicol. Environ. Sci.* **2**, 249-258.
- Singer, B., and Fraenkel-Conrat, H. (1974). Correlation between amino acid exchanges in coat protein of TMV mutants and the nature of the mutagens. *Virology* **60**, 485-490.
- Stark, A.-A., Zeiger, E., and Pagano, D.A. (1987). Glutathione mutagenesis in *Salmonella typhimurium* TA100: Dependence on a single enzyme, γ -glutamyltranspeptidase. *Mutat. Res.* **177**, 45-52.
- Storer, R.D., and Conolly, R.B. (1983). Comparative *in vivo* genotoxicity and acute hepatotoxicity of three 1,2-dihaloethanes. *Carcinogenesis* **4**, 1491-1494.
- Tarone, R.E. (1975). Tests for trend in life table analysis. *Biometrika* **62**, 679-682.
- Thilagar, A.K., and Kumaroo, V. (1983). Induction of chromosome damage by methylene chloride in CHO cells. *Mutat. Res.* **116**, 361-367.

- Tomoda, R., Kusunoki, S., Nakashima, K., and Matsunaga, T. (1986). Use of a copper-phthalocyanine membrane electrode for rapid preliminary detection of polycyclic mutagens. *Mutat. Res.* **164**, 203-208.
- Tonogai, Y., Ito, Y., Iwaida, M., Tati, M., Ose, Y., and Sato, T. (1979). Studies on the toxicity of coal tar dyes. II. Examination of the biological reaction of coal tar dyes to vital body. *J. Toxicol. Sci.* **4**, 211-220.
- Trueman, R.W., and Ashby, J. (1987). Lack of UDS activity in the livers of mice and rats exposed to dichloromethane. *Environ. Mol. Mutagen.* **10**, 189-195.
- Tucker, J.D., Xu, J., Stewart, J., Baciu, P.C., and Ong, T. (1986). Detection of sister chromatid exchanges induced by volatile genotoxicants. *Teratog. Carcinog. Mutagen.* **6**, 15-21.
- Tuite, M.F., Mundy, C.R., and Cox, B.S. (1981). Agents that cause a high frequency of genetic change from (*psi*⁺) to (*psi*⁻) in *Saccharomyces cerevisiae*. *Genetics* **98**, 691-711.
- U.S. Environmental Protection Agency (USEPA) (1984). Production/Exposure profile on methyl bromide. Office of Toxic Substances, USEPA, Washington, DC.
- Van Den Oever, R., Roosels, D., and Lahaye, D. (1982). Actual hazard of methyl bromide fumigation in soil disinfection. *Br. J. Ind. Med.* **39**, 140-144.
- Ward, J.B., Jr., Hokanson, J.A., Smith, E.R., Chang, L.W., Pereira, M.A., Whorton, E.B., Jr., and Legator, M.S. (1984). Sperm count, morphology and fluorescent body frequency in autopsy service workers exposed to formaldehyde. *Mutat. Res.* **130**, 417-424.
- Westbrook-Collins, B., Allen, J.W., Kligerman, A.D., Campbell, J.A., Erexson, G.L., Kari, F., and Zeiger, E. (1989). Dichloromethane-induced cytogenetic damage in mice. *Environ. Mol. Mutagen.* **14** (Suppl. 15), 217. (Abstr.)
- Winteringham, F.P.W. (1955). The fate of labelled insecticide residues in food products. IV. The possible toxicological and nutritional significance of fumigated wheat with methyl bromide. *J. Sci. Food Agric.* **6**, 269-274.
- Winteringham, F.P.W., and Barnes, J.M. (1955). Comparative response of insects and mammals to certain halogenated hydrocarbons used as insecticides. *Physiol. Rev.* **35**, 701-739.
- Working, P.K., and Bus, J.S. (1986). Failure of fertilization as a cause of preimplantation loss induced by methyl chloride in Fischer 344 rats. *Toxicol. Appl. Pharmacol.* **86**, 124-130.
- Working, P.K., Bus, J.S., and Hamm, T.E., Jr. (1985). Reproductive effects of inhaled methyl chloride in the male Fischer 344 rat. I. Mating performance and dominant lethal assay. *Toxicol. Appl. Pharmacol.* **77**, 133-143.
- Working, P.K., Doolittle, D.J., Smith-Oliver, T., White, R.D., and Butterworth, B.E. (1986). Unscheduled DNA synthesis in rat tracheal epithelial cells, hepatocytes and spermatocytes following exposure to methyl chloride *in vitro* and *in vivo*. *Mutat. Res.* **162**, 219-224.
- Zeiger, E. (1990). Mutagenicity of 42 chemicals in *Salmonella*. *Environ. Mol. Mutagen.* **16** (Suppl. 18), 32-54.
- Zwaveling, J.H., de Kort, W.L.A.M., Meulenbelt, J., Hezemans-Boer, M., van Vloten, W.A., and Sangster, B. (1987). Exposure of the skin to methyl bromide: A study of six cases occupationally exposed to high concentrations during fumigation. *Hum. Toxicol.* **6**, 491-495.

APPENDIX A
SUMMARY OF LESIONS IN MALE MICE
IN THE 2-YEAR INHALATION STUDY
OF METHYL BROMIDE

TABLE A1	Summary of the Incidence of Neoplasms in Male Mice in the 2-Year Inhalation Study of Methyl Bromide	56
TABLE A2	Individual Animal Tumor Pathology of Male Mice in the 2-Year Inhalation Study of Methyl Bromide	60
TABLE A3	Statistical Analysis of Primary Neoplasms in Male Mice in the 2-Year Inhalation Study of Methyl Bromide	84
TABLE A4	Summary of the Incidence of Nonneoplastic Lesions in Male Mice in the 2-Year Inhalation Study of Methyl Bromide	87

TABLE A1
Summary of the Incidence of Neoplasms in Male Mice in the 2-Year Inhalation Study
of Methyl Bromide

	0 ppm	10 ppm	33 ppm	100 ppm
Disposition Summary				
Animals initially in study	70	69 ^a	70	70
6-Month interim evaluation	10	10	9	- ^b
15-Month interim evaluation	10	9	10	-
Early deaths				
Natural deaths	6	9	4	14
Moribund kills	3	4	6	40
Accidental deaths	1	0	1	0
Survivors				
Terminal sacrifice	40	37	40	16
Animals examined microscopically	50	50	50	70
Alimentary System				
Gallbladder	(44)	(44)	(45)	(54)
Intestine large, cecum	(48)	(47)	(50)	(61)
Intestine small, duodenum	(46)	(44)	(50)	(61)
Intestine small, ileum	(46)	(46)	(50)	(61)
Carcinoma		1 (2%)		
Histiocytic sarcoma			1 (2%)	
Intestine small, jejunum	(46)	(46)	(50)	(60)
Liver	(50)	(50)	(50)	(70)
Hemangioma		1 (2%)		
Hemangiosarcoma			1 (2%)	1 (1%)
Hepatoblastoma	1 (2%)	1 (2%)		
Hepatocellular carcinoma	12 (24%)	13 (26%)	8 (16%)	4 (6%)
Hepatocellular carcinoma, multiple	2 (4%)	3 (6%)	2 (4%)	
Hepatocellular adenoma	12 (24%)	13 (26%)	12 (24%)	6 (9%)
Hepatocellular adenoma, multiple	5 (10%)	6 (12%)	5 (10%)	1 (1%)
Histiocytic sarcoma, metastatic, intestine small			1 (2%)	
Ito cell tumor benign	1 (2%)			
Mesentery		(2)	(1)	(2)
Hemangioma				1 (50%)
Pancreas	(50)	(50)	(50)	(70)
Carcinoma, metastatic, liver	1 (2%)	1 (2%)		
Acinus, carcinoma	1 (2%)			
Salivary glands	(50)	(50)	(50)	(68)
Stomach	(50)	(50)	(50)	(68)
Stomach, forestomach	(50)	(50)	(50)	(68)
Sarcoma			1 (2%)	
Cardiovascular System				
Heart	(50)	(50)	(50)	(70)
Carcinoma, metastatic		1 (2%)		
Carcinoma, metastatic, liver	1 (2%)		1 (2%)	
Sarcoma		1 (2%)		

TABLE A1
Summary of the Incidence of Neoplasms in Male Mice in the 2-Year Inhalation Study
of Methyl Bromide (continued)

	0 ppm	10 ppm	33 ppm	100 ppm
Endocrine System				
Adrenal gland	(49)	(48)	(50)	(68)
Hepatocolangiocarcinoma, metastatic, liver	1 (2%)			
Adrenal gland, cortex	(49)	(48)	(50)	(68)
Adenoma	1 (2%)			
Adrenal gland, medulla			(50)	(68)
Pheochromocytoma benign			1 (2%)	
Islets, pancreatic	(50)	(50)	(50)	(70)
Adenoma			2 (4%)	
Carcinoma, metastatic, liver	1 (2%)			
Thyroid gland	(49)	(49)	(50)	(65)
Follicular cell, adenoma	1 (2%)			
General Body System				
Tissue NOS	(1)	(1)		
Hepatocellular carcinoma, metastatic	1 (100%)			
Genital System				
Epididymis	(50)	(50)	(50)	(69)
Lymphoma malignant lymphocytic				
Lymphoma malignant mixed				
Prostate	(45)	(49)	(45)	(66)
Lymphoma malignant lymphocytic				
Lymphoma malignant mixed				
Seminal vesicle	(50)	(49)	(50)	(70)
Testes	(50)	(50)	(50)	(70)
Interstitial cell, adenoma	1 (2%)			
Hematopoietic System				
Bone marrow	(50)	(50)	(50)	(65)
Lymphoma malignant mixed				
Lymph node	(50)	(48)	(50)	(58)
Lymph node, bronchial	(27)	(14)	(21)	(18)
Carcinoma, metastatic, liver	2 (7%)			
Carcinoma, metastatic, lung		1 (7%)		
Histiocytic sarcoma, metastatic, intestine small			1 (5%)	
Lymph node, mandibular	(43)	(41)	(43)	(27)
Histiocytic sarcoma, metastatic, intestine small			1 (2%)	
Lymph node, mediastinal	(22)	(9)	(9)	(4)
Carcinoma, metastatic, liver		1 (11%)		
Lymph node, mesenteric	(44)	(46)	(41)	(46)
Histiocytic sarcoma metastatic, intestine small			1 (2%)	

TABLE A1
Summary of the Incidence of Neoplasms in Male Mice in the 2-Year Inhalation Study
of Methyl Bromide (continued)

	0 ppm	10 ppm	33 ppm	100 ppm
Hematopoietic System (continued)				
Spleen	(50)	(50)	(50)	(70)
Hemangiosarcoma, metastatic, liver				1 (1%)
Histiocytic sarcoma, metastatic, intestine small			1 (2%)	
Thymus	(41)	(36)	(41)	(42)
Carcinoma, metastatic, liver	1 (2%)	1 (3%)		
Carcinoma, metastatic, lung		1 (3%)		
Integumentary System				
Skin	(49)	(50)	(50)	(70)
Hemangiosarcoma, metastatic, liver				1 (1%)
Subcutaneous tissue, lipoma	1 (2%)			
Tail, sarcoma			1 (2%)	
Musculoskeletal System				
None				
Nervous System				
Brain	(50)	(50)	(50)	(70)
Respiratory System				
Larynx	(49)	(49)	(50)	(58)
Lung	(50)	(49)	(50)	(70)
Alveolar/bronchiolar adenoma	10 (20%)	6 (12%)	8 (16%)	4 (6%)
Alveolar/bronchiolar adenoma, multiple	2 (4%)	2 (4%)	2 (4%)	
Alveolar/bronchiolar carcinoma	2 (4%)	8 (16%)	5 (10%)	1 (1%)
Carcinoma, metastatic				1 (1%)
Carcinoma, metastatic, harderian gland		1 (2%)		
Carcinoma, metastatic, liver	6 (12%)	10 (20%)	4 (8%)	1 (1%)
Carcinoma, metastatic, pancreas	1 (2%)			
Hepatoblastoma, metastatic, liver	1 (2%)			
Hepatocellular carcinoma, metastatic	1 (2%)			
Histiocytic sarcoma, metastatic, intestine small			1 (2%)	
Nose	(50)	(50)	(50)	(69)
Trachea	(49)	(49)	(50)	(67)

TABLE A1
Summary of the Incidence of Neoplasms in Male Mice in the 2-Year Inhalation Study
of Methyl Bromide (continued)

	0 ppm	10 ppm	33 ppm	100 ppm
Special Senses System				
Harderian gland	(2)	(4)	(1)	
Adenoma	2 (100%)	2 (50%)	1 (100%)	
Carcinoma		2 (50%)		
Urinary System				
Kidney	(50)	(50)	(50)	(70)
Carcinoma, metastatic	1 (2%)			
Carcinoma, metastatic, liver	1 (2%)			
Carcinoma, metastatic, pancreas	1 (2%)			
Renal tubule, adenocarcinoma		1 (2%)		
Urinary bladder	(49)	(49)	(47)	(68)
Myxoma		1 (2%)		
Systemic Lesions				
Multiple organs ^c	(50)	(50)	(50)	(70)
Histiocytic sarcoma			1 (2%)	
Lymphoma malignant lymphocytic	1 (2%)	1 (2%)	1 (2%)	
Lymphoma malignant mixed	1 (2%)	2 (4%)	3 (6%)	1 (1%)
Lymphoma malignant undifferentiated cell			2 (4%)	1 (1%)
Tumor Summary				
Total animals with primary neoplasms ^d	37	41	38	16
Total primary neoplasms	56	64	56	20
Total animals with benign neoplasms	29	25	28	10
Total benign neoplasms	36	31	31	12
Total animals with malignant neoplasms	16	28	21	8
Total malignant neoplasms	20	33	25	8
Total animals with metastatic neoplasms	7	11	5	3
Total secondary neoplasms	20	17	11	4

^a One male mouse predesignated for 2-year study died before initiation of methyl bromide exposure and was not replaced.

^b Interim evaluations not performed on male mice exposed to 100 ppm.

^c The number in parentheses is the number of animals with any tissue examined microscopically.

^d Primary neoplasms: all neoplasms except metastatic neoplasms

TABLE A2
Individual Animal Tumor Pathology of Male Mice in the 2-Year Inhalation Study
of Methyl Bromide: 0 ppm (continued)

Number of Days on Study	7 7	
	2 3	
	9 0 0 0 0 0 0 0 0 0 1 1 1 1 1 1 1 1 1 1 2 2 2 2 2	
Carcass ID Number	0 0	
	6 2 2 3 3 5 5 6 6 7 2 2 2 2 3 4 4 6 6 6 4 4 5 5 6	
	2 1 8 2 3 1 7 6 8 0 2 3 4 7 6 0 2 1 3 9 4 6 3 8 4	Total Tissues/Tumors
	1 1	
Respiratory System		
Larynx	+ +	49
Lung	+ +	50
Alveolar/bronchiolar adenoma		10
Alveolar/bronchiolar adenoma, multiple	X X X	
Alveolar/bronchiolar carcinoma		2
Alveolar/bronchiolar carcinoma, multiple	X	
Alveolar/bronchiolar carcinoma		2
Carcinoma, metastatic, liver		6
Carcinoma, metastatic, pancreas		1
Hepatoblastoma, metastatic, liver		1
Hepatocellular carcinoma, metastatic	X	
Nose	+ +	50
Trachea	+ +	49
Special Senses System		
Harderian gland		2
Adenoma		2
Urinary System		
Kidney	+ +	50
Carcinoma, metastatic		1
Carcinoma, metastatic, liver		1
Carcinoma, metastatic, pancreas		1
Urethra		
Urinary bladder	+ + + + + + + + + + + + M + + + + + + + + + + + + + +	49
Systemic Lesions		
Multiple organs	+ +	50
Lymphoma malignant lymphocytic		1
Lymphoma malignant mixed	X	

TABLE A2
Individual Animal Tumor Pathology of Male Mice in the 2-Year Inhalation Study
of Methyl Bromide: 10 ppm (continued)

Number of Days on Study	7 7	
	2 2 2 2 2 3 3 3 3 3 3 3 3 3 3 3 3 3 3 3 3 3 3	
	9 9 9 9 9 0 0 0 0 0 0 0 0 0 1 1 1 1 1 1 2 2 2 2 2	
Carcass ID Number	2 2	Total Tissues/ Tumors
	3 4 4 6 6 3 3 3 4 5 6 7 7 2 2 3 4 6 6 5 5 5 6 6 6	
	9 3 9 4 7 4 5 7 1 9 2 0 2 5 9 8 4 3 5 4 5 8 0 1 6	
Special Senses System		
Ear		1
Harderian gland	+	4
Adenoma	X	2
X Carcinoma		2
Urinary System		
Kidney	+ +	49
Renal tubule, adenocarcinoma		1
Urinary bladder	+ +	49
Myxoma		1
Systemic Lesions		
Multiple organs	+ +	49
Lymphoma malignant lymphocytic	X	1
Lymphoma malignant mixed		2

TABLE A2
Individual Animal Tumor Pathology of Male Mice in the 2-Year Inhalation Study
of Methyl Bromide: 33 ppm (continued)

Number of Days on Study	7 7	
	2 2 3	
	9 9 0 0 0 0 0 0 0 0 1 1 1 1 1 1 1 1 1 1 2 2 2 2 2 2	
Carcass ID Number	4 4 3 4 4 4 4 4 4 4 3 3 3 4 4 4 4 4 4 4 4 4 4 4 4	Total Tissues/ Tumors
	3 3 9 0 0 0 0 2 3 4 9 9 9 1 1 2 3 3 4 1 2 2 3 3 3	
	6 9 5 4 6 7 9 5 4 4 6 7 8 0 4 0 5 7 3 8 6 7 0 3 8	
	1 1	
Respiratory System		
Larynx	+ +	50
Lung	+ +	50
Alveolar/bronchiolar adenoma		8
Alveolar/bronchiolar adenoma, multiple		2
Alveolar/bronchiolar carcinoma		5
Carcinoma, metastatic, liver		4
Histiocytic sarcoma, metastatic, intestine small		1
Nose	+ +	50
Trachea	+ +	50
Special Senses System		
Eye	+	1
Harderian gland	+	1
Adenoma	X	1
Urinary System		
Kidney	+ +	50
Urinary bladder	+ + M + + + + + + + + + + + + + M + + + + + + + + + +	47
Systemic Lesions		
Multiple organs	+ +	50
Histiocytic sarcoma		1
Lymphoma malignant lymphocytic		1
Lymphoma malignant mixed		3
Lymphoma malignant undifferentiated cell type		2

TABLE A2
Individual Animal Tumor Pathology of Male Mice in the 2-Year Inhalation Study
of Methyl Bromide: 100 ppm (continued)

Number of Days on Study	6 6 7 7 7 7 7 7 7 7 7 7 7 7 7 7 7 7	4 8 1 2 2 2 2 2 3 3 3 3 3 3 3 3 3 3	8 8 5 3 8 8 9 9 0 0 0 1 1 1 2 2 2 2
Carcass ID Number	5 5 5 5 5 6 5 6 5 5 5 5 5 5 5 5 5 5	8 6 8 6 7 0 5 1 6 6 9 5 6 8 5 5 9 9	9 2 1 1 5 1 3 6 3 7 7 7 9 8 8 9 0 2
Total Tissues/ Tumors	1 1 1 1 1 1 1 1 1 1 1 1 1 1 1 1 1 1	64	
Alimentary System			
Esophagus	+ + + + + + + + + + + + + + + + + +	64	
Gallbladder	+ + + + + + + + + + + + + + + + + +	54	
Intestine large	+ + + + + + + + + + + + + + + + + +	69	
Intestine large, cecum	A + A + + + + + + + + + + + + + +	61	
Intestine large, colon	+ + A + + + + + + + + + + + + + + +	68	
Intestine large, rectum	+ + + + + + + + + + + + + + + + + +	69	
Intestine small	+ + + + + + + + + + + + + + + + + +	65	
Intestine small, duodenum	A + + + + + + + + + + + + + + + + +	61	
Intestine small, ileum	+ + A + + + M + + + + + + + + + + +	61	
Intestine small, jejunum	A + A + + + + + + + + + + + + + + +	60	
Liver	+ + + + + + + + + + + + + + + + + +	70	
Hemangiosarcoma		1	
Hepatocellular carcinoma	X	4	
Hepatocellular adenoma		6	
Hepatocellular adenoma, multiple		1	
Mesentery		2	
Hemangioma	X	1	
Pancreas	+ + + + + + + + + + + + + + + + + +	70	
Salivary glands	+ + + + + + + + + + + + + + + + + +	68	
Stomach	+ + A + + + + + + + + + + + + + + +	68	
Stomach, forestomach	+ + A + + + + + + + + + + + + + + +	68	
Stomach, glandular	+ + A + + + + + + + + + + + + + + +	68	
Cardiovascular System			
Heart	+ + + + + + + + + + + + + + + + + +	70	
Endocrine System			
Adrenal gland	+ + + + + + + + + + + + + + + + + +	68	
Adrenal gland, cortex	+ + + + + + + + + + + + + + + + + +	68	
Adrenal gland, medulla	+ + + + + + + + + + + + + + + + + +	68	
Islets, pancreatic	+ + + + + + + + + + + + + + + + + +	70	
Parathyroid gland	+ + + M + + + + M + M + + + + + + +	45	
Pituitary gland	+ + + M + + + + + + M + + + + M M + + +	51	
Thyroid gland	+ + + + + + + + + + + + + + + + + +	65	
General Body System			
None			
Genital System			
Epididymis	+ + + + + + + + + + + + + + + + + +	69	
Preputial gland		2	
Prostate	+ + + + + + M + + + + + + + + + + M +	66	
Seminal vesicle	+ + + + + + + + + + + + + + + + + +	70	
Testes	+ + + + + + + + + + + + + + + + + +	70	

TABLE A2
Individual Animal Tumor Pathology of Male Mice in the 2-Year Inhalation Study
of Methyl Bromide: 100 ppm (continued)

Number of Days on Study	6 6 7 7 7 7 7 7 7 7 7 7 7 7 7 7 7 7 7	4 8 1 2 2 2 2 2 3 3 3 3 3 3 3 3 3 3 3	8 8 5 3 8 8 9 9 0 0 0 1 1 1 2 2 2 2 2	
Carcass ID Number	5 5 5 5 5 6 5 6 5 5 5 5 5 5 5 5 5 5 6	8 6 8 6 7 0 5 1 6 6 9 5 6 8 5 5 9 9 9 1	9 2 1 1 5 1 3 6 3 7 7 7 9 8 8 9 0 2 9 0	
	1 1 1 1 1 1 1 1 1 1 1 1 1 1 1 1 1 1 1		Total Tissues/Tumors	
Hematopoietic System				
Bone marrow	+ + + + + + + + + + + + + + + + + +			65
Lymph node	+ + + + + + + + + + + + + + + + + +			58
Lymph node, bronchial	M + M + + M M + M M M M M M M M + + + M			18
Lymph node, mandibular	M + + M + + + + + + + + + + + + + +			27
Lymph node, mediastinal	M M M M M M M M + + M M + M M M M M M			4
Lymph node, mesenteric	+ M + + M + + + + + + + + M + + + M + M			46
Spleen	+ + + + + + + + + + + + + + + + + +			70
Hemangiosarcoma, metastatic, liver	X			1
Thymus	M + + + M + + M M + + M + + + + M + M +			42
Integumentary System				
Mammary gland	M M M M M M M M M M M M M M M M M M			6
Skin	+ + + + + + + + + + + + + + + + + +			70
Hemangiosarcoma, metastatic, liver	X			1
Musculoskeletal System				
Bone	+ + + + + + + + + + + + + + + + + +			69
Nervous System				
Brain	+ + + + + + + + + + + + + + + + + +			70
Peripheral nerve	+ + + + + + + + + + + + + + + + + +			66
Spinal cord	+ + + + + + + + + + + + + + + + + +			70
Respiratory System				
Larynx	+ + + + + + + + + + + + + + + + + +			58
Lung	+ + + + + + + + + + + + + + + + + +			70
Alveolar/bronchiolar adenoma	X			4
Alveolar/bronchiolar carcinoma	X			1
Carcinoma, metastatic	X			1
Carcinoma, metastatic, liver	X			1
Nose	+ + + + + + + + + + + + + + + + + +			69
Trachea	+ + + + + + + + + + + + + + + + + +			67
Special Senses System				
Eye				1
Urinary System				
Kidney	+ + + + + + + + + + + + + + + + + +			70
Urinary bladder	+ + + + + + + + + + + + + + + + + +			68
Systemic Lesions				
Multiple organs	+ + + + + + + + + + + + + + + + + +			70
Lymphoma malignant mixed	X			1
Lymphoma malignant undifferentiated cell type	X			1

TABLE A3
Statistical Analysis of Primary Neoplasms in Male Mice in the 2-Year Inhalation Study of Methyl Bromide

	0 ppm	10 ppm	33 ppm	100 ppm
Harderian Gland: Adenoma or Carcinoma				
Overall rates ^a	2/50 (4%)	4/50 (8%)	1/51 (2%)	0/70 (0%)
Adjusted rates ^b	4.4%	10.3%	2.5%	0.0%
Terminal rates ^c	0/40 (0%)	3/37 (8%)	1/40 (3%)	0/16 (0%)
First incidence (days)	603	695	727 (T)	- ^e
Life table tests ^d	P=0.205N	P=0.308	P=0.514N	P=0.443N
Logistic regression tests ^d	P=0.136N	P=0.330	P=0.486N	P=0.299N
Cochran-Armitage test ^d	P=0.044N			
Fisher exact test ^d		P=0.339	P=0.492N	P=0.172N
Liver: Hepatocellular Adenoma				
Overall rates	17/50 (34%)	19/50 (38%)	17/51 (33%)	7/70 (10%)
Adjusted rates	40.4%	49.8%	40.2%	34.8%
Terminal rates	15/40 (38%)	18/37 (49%)	15/40 (38%)	4/16 (25%)
First incidence (days)	653	646	520	542
Life table tests	P=0.481N	P=0.305	P=0.580	P=0.599
Logistic regression tests	P=0.260N	P=0.320	P=0.550	P=0.375N
Cochran-Armitage test	P<0.001N			
Fisher exact test		P=0.418	P=0.555N	P=0.001N
Liver: Hepatocellular Carcinoma				
Overall rates	14/50 (28%)	16/50 (32%)	10/51 (20%)	4/70 (6%)
Adjusted rates	31.6%	37.1%	22.5%	21.9%
Terminal rates	10/40 (25%)	10/37 (27%)	6/40 (15%)	3/16 (19%)
First incidence (days)	603	566	481	542
Life table tests	P=0.179N	P=0.328	P=0.270N	P=0.339N
Logistic regression tests	P=0.041N	P=0.360	P=0.239N	P=0.178N
Cochran-Armitage test	P<0.001N			
Fisher exact test		P=0.414	P=0.225N	P<0.001N
Liver: Hepatocellular Carcinoma or Hepatoblastoma				
Overall rates	14/50 (28%)	17/50 (34%)	10/51 (20%)	4/70 (6%)
Adjusted rates	31.6%	38.5%	22.5%	21.9%
Terminal rates	10/40 (25%)	10/37 (27%)	6/40 (15%)	3/16 (19%)
First incidence (days)	603	442	481	542
Life table tests	P=0.157N	P=0.261	P=0.270N	P=0.339N
Logistic regression tests	P=0.024N	P=0.302	P=0.239N	P=0.178N
Cochran-Armitage test	P<0.001N			
Fisher exact test		P=0.333	P=0.225N	P<0.001N
Liver: Hepatocellular Adenoma or Carcinoma				
Overall rates	28/50 (56%)	31/50 (62%)	26/51 (51%)	9/70 (13%)
Adjusted rates	60.9%	70.4%	56.4%	45.6%
Terminal rates	22/40 (55%)	24/37 (65%)	20/40 (50%)	6/16 (38%)
First incidence (days)	603	566	481	542
Life table tests	P=0.149N	P=0.220	P=0.446N	P=0.290N
Logistic regression tests	P=0.011N	P=0.226	P=0.439N	P=0.072N
Cochran-Armitage test	P<0.001N			
Fisher exact test		P=0.342	P=0.380N	P<0.001N

TABLE A3
Statistical Analysis of Primary Neoplasms in Male Mice in the 2-Year Inhalation Study
of Methyl Bromide (continued)

	0 ppm	10 ppm	33 ppm	100 ppm
Lung: Alveolar/bronchiolar Adenoma				
Overall rates	12/50 (24%)	8/49 (16%)	10/51 (20%)	4/70 (6%)
Adjusted rates	28.3%	21.6%	23.5%	18.7%
Terminal rates	10/40 (25%)	8/37 (22%)	8/40 (20%)	2/16 (13%)
First incidence (days)	653	727 (T)	481	485
Life table tests	P=0.473N	P=0.289N	P=0.415N	P=0.440N
Logistic regression tests	P=0.237N	P=0.275N	P=0.414N	P=0.225N
Cochran-Armitage test	P=0.005N			
Fisher exact test		P=0.242N	P=0.385N	P=0.004N
Lung: Alveolar/bronchiolar Carcinoma				
Overall rates	2/50 (4%)	8/49 (16%)	5/51 (10%)	1/70 (1%)
Adjusted rates	4.5%	20.2%	12.5%	6.3%
Terminal rates	1/40 (3%)	6/37 (16%)	5/40 (13%)	1/16 (6%)
First incidence (days)	484	625	727 (T)	727 (T)
Life table tests	P=0.426N	P=0.040	P=0.217	P=0.714
Logistic regression tests	P=0.279N	P=0.044	P=0.222	P=0.623N
Cochran-Armitage test	P=0.035N			
Fisher exact test		P=0.043	P=0.226	P=0.375N
Lung: Alveolar/bronchiolar Adenoma or Carcinoma				
Overall rates	14/50 (28%)	14/49 (29%)	14/51 (27%)	5/70 (7%)
Adjusted rates	32.1%	35.6%	33.0%	24.5%
Terminal rates	11/40 (28%)	12/37 (32%)	12/40 (30%)	3/16 (19%)
First incidence (days)	484	625	481	485
Life table tests	P=0.404N	P=0.493	P=0.577	P=0.454N
Logistic regression tests	P=0.141N	P=0.531	P=0.586	P=0.190N
Cochran-Armitage test	P<0.001N			
Fisher exact test		P=0.563	P=0.564N	P=0.002N
All Organs: Malignant Lymphoma: Lymphocytic, Mixed, or Undifferentiated Cell Type				
Overall rates	2/50 (4%)	2/50 (4%)	6/51 (12%)	2/70 (3%)
Adjusted rates	4.5%	4.8%	13.9%	11.5%
Terminal rates	1/40 (3%)	1/37 (3%)	4/40 (10%)	1/16 (6%)
First incidence (days)	484	420	597	714
Life table tests	P=0.240	P=0.667	P=0.140	P=0.391
Logistic regression tests	P=0.560	P=0.637N	P=0.152	P=0.546
Cochran-Armitage test	P=0.368N			
Fisher exact test		P=0.691N	P=0.141	P=0.555N
All Organs: Benign Tumors				
Overall rates	29/50 (58%)	25/50 (50%)	29/51 (57%)	10/70 (14%)
Adjusted rates	65.8%	65.7%	64.2%	47.4%
Terminal rates	25/40 (63%)	24/37 (65%)	24/40 (60%)	6/16 (38%)
First incidence (days)	603	646	2	485
Life table tests	P=0.326N	P=0.425N	P=0.566	P=0.340N
Logistic regression tests	P=0.037N	P=0.383N	P=0.575N	P=0.073N
Cochran-Armitage test	P<0.001N			
Fisher exact test		P=0.274N	P=0.534N	P<0.001N

TABLE A3
Statistical Analysis of Primary Neoplasms in Male Mice in the 2-Year Inhalation Study
of Methyl Bromide (continued)

	0 ppm	10 ppm	33 ppm	100 ppm
All Organs: Malignant Tumors				
Overall rates	16/50 (32%)	28/50 (56%)	21/51 (41%)	9/70 (13%)
Adjusted rates	35.3%	60.8%	44.5%	43.3%
Terminal rates	11/40 (28%)	19/37 (51%)	14/40 (35%)	5/16 (31%)
First incidence (days)	484	420	481	496
Life table tests	P=0.542	P=0.013	P=0.219	P=0.305
Logistic regression tests	P=0.085N	P=0.011	P=0.220	P=0.604
Cochran-Armitage test	P<0.001N			
Fisher exact test		P=0.013	P=0.227	P=0.011N
All Organs: Benign and Malignant Tumors				
Overall rates	37/50 (74%)	41/50 (82%)	39/51 (76%)	17/70 (24%)
Adjusted rates	78.7%	87.2%	78.0%	72.9%
Terminal rates	30/40 (75%)	31/37 (84%)	29/40 (73%)	10/16 (63%)
First incidence (days)	484	420	2	485
Life table tests	P=0.522	P=0.134	P=0.415	P=0.394
Logistic regression tests	P=0.005N	P=0.137	P=0.441	P=0.212N
Cochran-Armitage test	P<0.001N			
Fisher exact test		P=0.235	P=0.477	P<0.001N

(T) Terminal sacrifice

^a Number of tumor-bearing animals/number of animals examined. Denominator is number of animals examined microscopically for adrenal gland, bone marrow, brain, clitoral gland, epididymis, gallbladder (mouse), heart, kidney, larynx, liver, lung, nose, ovary, pancreas, parathyroid gland, pituitary gland, preputial gland, prostate gland, salivary gland, spleen, testes, thyroid gland, and urinary bladder; for other tissues, denominator is number of animals necropsied.

^b Kaplan-Meier estimated tumor incidence at the end of the study after adjustment for intercurrent mortality

^c Observed incidence at terminal kill

^d Beneath the control incidence are the P values associated with the trend test. Beneath the dosed group incidence are the P values corresponding to pairwise comparisons between the controls and that dosed group. The life table analysis regards tumors in animals dying prior to terminal kill as being (directly or indirectly) the cause of death. The logistic regression tests regard these lesions as nonfatal. The Cochran-Armitage and Fisher exact tests compare directly the overall incidence rates. For all tests, a negative trend or a lower incidence in a dose group is indicated by N.

^e Not applicable; no tumors in animal group

TABLE A4
Summary of the Incidence of Nonneoplastic Lesions in Male Mice in the 2-Year Inhalation Study of Methyl Bromide

	0 ppm	10 ppm	33 ppm	100 ppm
Disposition Summary				
Animals initially in study	70	69 ^a	70	70
6-Month interim evaluation	10	10	9	^b
15-Month interim evaluation	10	9	10	-
Early deaths				
Natural deaths	6	9	4	14
Moribund kills	3	4	6	40
Accidental deaths	1	0	1	0
Survivors				
Terminal sacrifice	40	37	40	16
Animals examined microscopically	50	50	50	70
Alimentary System				
Gallbladder	(44)	(44)	(45)	(54)
Hyperplasia		1 (2%)		
Hyperplasia, focal	1 (2%)			
Infiltration cellular, lymphocytic	1 (2%)		1 (2%)	
Intestine large, cecum	(48)	(47)	(50)	(61)
Intestine large, colon	(49)	(49)	(50)	(68)
Diverticulum	1 (2%)			
Intestine small, ileum	(46)	(46)	(50)	(61)
Liver	(50)	(50)	(50)	(70)
Basophilic focus	2 (4%)	1 (2%)	1 (2%)	2 (3%)
Clear cell focus	4 (8%)	5 (10%)	8 (16%)	
Congestion		1 (2%)		
Cyst	1 (2%)			
Eosinophilic focus	5 (10%)	2 (4%)		
Hematopoietic cell proliferation				1 (1%)
Infiltration cellular, lymphocytic	2 (4%)	1 (2%)	1 (2%)	2 (3%)
Inflammation	10 (20%)	1 (2%)	3 (6%)	2 (3%)
Mineralization		1 (2%)		1 (1%)
Mixed cell focus	7 (14%)	5 (10%)	1 (2%)	
Necrosis	1 (2%)	2 (4%)	3 (6%)	4 (6%)
Bile duct, proliferation	1 (2%)			
Hepatocyte, vacuolization cytoplasmic	7 (14%)	8 (16%)	7 (14%)	18 (26%)
Kupffer cell, hyperplasia				1 (1%)
Mesentery		(2)	(1)	(2)
Fat, necrosis		2 (100%)	1 (100%)	1 (50%)

TABLE A4
Summary of the Incidence of Nonneoplastic Lesions in Male Mice in the 2-Year Inhalation Study
of Methyl Bromide (continued)

	0 ppm	10 ppm	33 ppm	100 ppm
Alimentary System (continued)				
Pancreas	(50)	(50)	(50)	(70)
Basophilic focus	1 (2%)			
Infiltration cellular, lymphocytic	7 (14%)	3 (6%)	8 (16%)	2 (3%)
Inflammation, chronic	1 (2%)			
Polyarteritis	1 (2%)			
Acinus, atrophy	1 (2%)	1 (2%)	2 (4%)	3 (4%)
Acinus, cyst		1 (2%)		
Acinus, degeneration				1 (1%)
Acinus, hyperplasia		1 (2%)	1 (2%)	
Fat, necrosis		1 (2%)		
Salivary glands	(50)	(50)	(50)	(68)
Infiltration cellular, lymphocytic	25 (50%)	23 (46%)	24 (48%)	6 (9%)
Stomach, forestomach	(50)	(50)	(50)	(68)
Infiltration cellular, lymphocytic	1 (2%)			
Stomach, glandular	(50)	(50)	(50)	(68)
Atrophy		2 (4%)	1 (2%)	
Hyperplasia	3 (6%)	1 (2%)	3 (6%)	
Infiltration cellular, lymphocytic	2 (4%)		1 (2%)	
Inflammation, chronic	3 (6%)	1 (2%)	1 (2%)	2 (3%)
Metaplasia	2 (4%)	1 (2%)		1 (1%)
Mineralization	1 (2%)	1 (2%)	1 (2%)	1 (1%)
Necrosis				1 (1%)
Tooth	(2)		(4)	
Dysplasia	2 (100%)		4 (100%)	
Cardiovascular System				
Heart	(50)	(50)	(50)	(70)
Cardiomyopathy, chronic	4 (8%)	7 (14%)	10 (20%)	24 (34%)
Degeneration				32 (46%)
Embolus bacterial			1 (2%)	
Inflammation, acute			1 (2%)	
Inflammation, chronic active		2 (4%)		2 (3%)
Mineralization	1 (2%)			2 (3%)
Necrosis, acute		1 (2%)		
Polyarteritis		1 (2%)	1 (2%)	
Atrium, thrombus			1 (2%)	1 (1%)

TABLE A4
Summary of the Incidence of Nonneoplastic Lesions in Male Mice in the 2-Year Inhalation Study
of Methyl Bromide (continued)

	0 ppm	10 ppm	33 ppm	100 ppm
Endocrine System				
Adrenal gland	(49)	(48)	(50)	(68)
Angiectasis			1 (2%)	
Necrosis			1 (2%)	
Pigmentation	2 (4%)	2 (4%)	3 (6%)	
Spindle cell, hyperplasia	41 (84%)	31 (65%)	38 (76%)	33 (49%)
Adrenal gland, cortex	(49)	(48)	(50)	(68)
Cyst	1 (2%)			
Hyperplasia	10 (20%)	2 (4%)	3 (6%)	2 (3%)
Hypertrophy	12 (24%)	3 (6%)	5 (10%)	3 (4%)
Vacuolization cytoplasmic	15 (31%)	11 (23%)	12 (24%)	4 (6%)
Adrenal gland, medulla	(49)	(48)	(50)	(68)
Hyperplasia	1 (2%)	4 (8%)		1 (1%)
Islets, pancreatic	(50)	(50)	(50)	(70)
Hyperplasia	8 (16%)	10 (20%)	17 (34%)	1 (1%)
Parathyroid gland	(39)	(47)	(48)	(45)
Cyst		1 (2%)	2 (4%)	1 (2%)
Pituitary gland	(43)	(45)	(46)	(51)
Cyst	3 (7%)	1 (2%)		
Pars distalis, hyperplasia			1 (2%)	
Thyroid gland	(49)	(49)	(50)	(65)
Cyst	2 (4%)	1 (2%)		1 (2%)
Follicular cell, hyperplasia	2 (4%)	3 (6%)	3 (6%)	1 (2%)
General Body System				
Tissue NOS	(1)	(1)		
Necrosis		1 (100%)		
Genital System				
Epididymis	(50)	(50)	(50)	(69)
Degeneration				1 (1%)
Infiltration cellular, lymphocytic		2 (4%)		
Inflammation	1 (2%)			
Inflammation, chronic active		1 (2%)	1 (2%)	
Mineralization		1 (2%)		
Polyarteritis			1 (2%)	
Preputial gland	(6)	(4)	(9)	(2)
Cyst	6 (100%)	4 (100%)	8 (89%)	2 (100%)
Infiltration cellular, lymphocytic	1 (17%)			
Inflammation, chronic active	2 (33%)		2 (22%)	
Prostate	(45)	(49)	(45)	(66)
Infiltration cellular, lymphocytic	2 (4%)	5 (10%)	1 (2%)	
Inflammation, chronic active	2 (4%)			
Testes	(50)	(50)	(50)	(70)
Atrophy		1 (2%)		
Degeneration		1 (2%)		
Inflammation, chronic active	1 (2%)		1 (2%)	28 (40%)
Mineralization		1 (2%)	2 (4%)	1 (1%)
Polyarteritis	1 (2%)			

TABLE A4
Summary of the Incidence of Nonneoplastic Lesions in Male Mice in the 2-Year Inhalation Study
of Methyl Bromide (continued)

	0 ppm	10 ppm	33 ppm	100 ppm
Hematopoietic System				
Bone marrow	(50)	(50)	(50)	(65)
Hyperplasia, RE cell			1 (2%)	
Myelofibrosis	1 (2%)		1 (2%)	
Lymph node	(50)	(48)	(50)	(58)
Lumbar, hyperplasia	1 (2%)			
Lymph node, bronchial	(27)	(14)	(21)	(18)
Hyperplasia		2 (14%)	1 (5%)	
Lymph node, mandibular	(43)	(41)	(43)	(27)
Hyperplasia		1 (2%)	2 (5%)	
Pigmentation				1 (4%)
Lymph node, mediastinal	(22)	(9)	(9)	(4)
Hyperplasia	2 (9%)			
Lymph node, mesenteric	(44)	(46)	(41)	(46)
Angiectasis			1 (2%)	
Edema			1 (2%)	
Hyperplasia	1 (2%)			
Spleen	(50)	(50)	(50)	(70)
Atrophy		2 (4%)		10 (14%)
Degeneration				1 (1%)
Hematopoietic cell proliferation	2 (4%)	12 (24%)	9 (18%)	1 (1%)
Hyperplasia, lymphoid	3 (6%)	3 (6%)	1 (2%)	
Hyperplasia, RE cell			1 (2%)	
Thymus	(41)	(36)	(41)	(42)
Atrophy	1 (2%)	1 (3%)	1 (2%)	11 (26%)
Cyst	1 (2%)	1 (3%)		
Necrosis				9 (21%)
Integumentary System				
Skin	(49)	(50)	(50)	(70)
Abscess		1 (2%)	1 (2%)	
Alopecia		2 (4%)	1 (2%)	1 (1%)
Cyst	1 (2%)	4 (8%)	3 (6%)	
Infiltration cellular, lymphocytic		2 (4%)		1 (1%)
Inflammation, chronic active	2 (4%)		1 (2%)	2 (3%)
Prepuce, inflammation, chronic active	2 (4%)		1 (2%)	
Musculoskeletal System				
Bone			(50)	(69)
Sternum, dysplasia			3 (6%)	14 (20%)

TABLE A4
Summary of the Incidence of Nonneoplastic Lesions in Male Mice in the 2-Year Inhalation Study
of Methyl Bromide (continued)

	0 ppm	10 ppm	33 ppm	100 ppm
Nervous System				
Brain	(50)	(50)	(50)	(70)
Infiltration cellular, lymphocytic	1 (2%)			
Polyarteritis			1 (2%)	
Cerebellum, degeneration				31 (44%)
Cerebrum, degeneration				11 (16%)
Thalamus, mineralization	28 (56%)	25 (50%)	25 (50%)	15 (21%)
Ventricle, dilatation		1 (2%)		
Peripheral nerve	(47)	(50)		
Sciatic, infiltration cellular, lymphocytic		1 (2%)		
Spinal cord	(49)	(50)	(49)	(70)
Respiratory System				
Larynx	(49)	(49)	(50)	(58)
Inflammation, suppurative		2 (4%)	1 (2%)	
Lung	(50)	(49)	(50)	(70)
Adenomatosis	1 (2%)	1 (2%)	2 (4%)	1 (1%)
Hemorrhage		1 (2%)	1 (2%)	2 (3%)
Infiltration cellular, histiocytic	2 (4%)	6 (12%)	3 (6%)	
Inflammation, chronic		1 (2%)		
Pigmentation			1 (2%)	1 (1%)
Mediastinum, inflammation, acute				1 (1%)
Nose	(50)	(50)	(50)	(69)
Inflammation, acute	1 (2%)	2 (4%)	5 (10%)	8 (12%)
Inflammation, suppurative	1 (2%)		1 (2%)	2 (3%)
Olfactory epithelium, metaplasia			1 (2%)	2 (3%)
Olfactory epithelium, necrosis				6 (9%)
Respiratory epithelium, metaplasia				1 (1%)
Respiratory epithelium, necrosis				1 (1%)
Trachea	(49)	(49)	(50)	(67)
Special Senses System				
Eye			(1)	(1)
Cornea, inflammation			1 (100%)	

TABLE A4
Summary of the Incidence of Nonneoplastic Lesions in Male Mice in the 2-Year Inhalation Study
of Methyl Bromide (continued)

	0 ppm	10 ppm	33 ppm	100 ppm
Urinary System				
Kidney	(50)	(50)	(50)	(70)
Infarct	3 (6%)	2 (4%)	1 (2%)	2 (3%)
Infiltration cellular, lymphocytic	19 (38%)	16 (32%)	18 (36%)	8 (11%)
Inflammation, chronic	20 (40%)	6 (12%)	16 (32%)	3 (4%)
Cortex, cyst	7 (14%)	1 (2%)	5 (10%)	2 (3%)
Renal tubule, casts protein	3 (6%)	6 (12%)	6 (12%)	5 (7%)
Renal tubule, hyperplasia	1 (2%)			
Renal tubule, mineralization	38 (76%)	30 (60%)	32 (64%)	6 (9%)
Renal tubule, pigmentation			1 (2%)	1 (1%)
Renal tubule, vacuolization cytoplasmic	4 (8%)	2 (4%)	1 (2%)	
Urethra	(1)			
Foreign body	1 (100%)			
Urinary bladder	(49)	(49)	(47)	(68)
Hyperplasia				1 (1%)
Infiltration cellular, lymphocytic	7 (14%)	3 (6%)	4 (9%)	1 (1%)
Inflammation, chronic	2 (4%)			1 (1%)
Polyarteritis	1 (2%)		1 (2%)	

^a One male mouse predesignated for the 2-year study died before initiation of methyl bromide exposure and was not replaced.

^b Interim evaluation not performed on male mice exposed to 100 ppm.

APPENDIX B
SUMMARY OF LESIONS IN FEMALE MICE
IN THE 2-YEAR INHALATION STUDY
OF METHYL BROMIDE

TABLE B1	Summary of the Incidence of Neoplasms in Female Mice in the 2-Year Inhalation Study of Methyl Bromide	94
TABLE B2	Individual Animal Tumor Pathology of Female Mice in the 2-Year Inhalation Study of Methyl Bromide	98
TABLE B3	Statistical Analysis of Primary Neoplasms in Female Mice in the 2-Year Inhalation Study of Methyl Bromide	123
TABLE B4	Summary of the Incidence of Nonneoplastic Lesions in Female Mice in the 2-Year Inhalation Study of Methyl Bromide	127

TABLE B1
Summary of the Incidence of Neoplasms in Female Mice in the 2-Year Inhalation Study of Methyl Bromide

	0 ppm	10 ppm	33 ppm	100 ppm
Disposition Summary				
Animals initially in study	71	70	70	70
6-Month interim evaluation	10	10	10	8
15-Month interim evaluation	9	10	10	0
Early deaths				
Natural deaths	7	3	1	6
Moribund kills	9	6	4	16
Survivors				
Terminal sacrifice	36	41	45	40
Animals examined microscopically	50	50	50	60
Alimentary System				
Gallbladder	(46)	(49)	(49)	(58)
Intestine large, cecum	(50)	(50)	(50)	(58)
Intestine large, colon	(50)	(50)	(50)	(60)
Intestine small, duodenum	(48)	(49)	(50)	(58)
Adenoma			1 (2%)	
Intestine small, ileum	(49)	(50)	(49)	(58)
Liver	(50)	(50)	(50)	(60)
Hepatocellular carcinoma	4 (8%)	3 (6%)	2 (4%)	1 (2%)
Hepatocellular carcinoma, multiple		1 (2%)		
Hepatocellular adenoma	5 (10%)	7 (14%)	6 (12%)	4 (7%)
Hepatocellular adenoma, multiple	1 (2%)		1 (2%)	1 (2%)
Histiocytic sarcoma			1 (2%)	1 (2%)
Histiocytic sarcoma, metastatic, spleen	2 (4%)			
Histiocytic sarcoma, metastatic, uterus	1 (2%)	1 (2%)		
Pancreas	(50)	(50)	(50)	(60)
Hemangioma				1 (2%)
Histiocytic sarcoma, metastatic, liver				1 (2%)
Histiocytic sarcoma, metastatic, spleen	2 (4%)			
Acinus, carcinoma	1 (2%)			
Salivary glands	(49)	(49)	(50)	(60)
Histiocytic sarcoma, metastatic, spleen	1 (2%)			
Stomach	(50)	(50)	(50)	(60)
Cardiovascular System				
Heart	(50)	(50)	(50)	(59)
Carcinoma, metastatic, kidney		1 (2%)		
Hemangiosarcoma		1 (2%)		

TABLE B1
Summary of the Incidence of Neoplasms in Female Mice in the 2-Year Inhalation Study
of Methyl Bromide (continued)

	0 ppm	10 ppm	33 ppm	100 ppm
Endocrine System				
Adrenal gland	(50)	(50)	(50)	(59)
Carcinoma, metastatic, kidney		1 (2%)		
Adrenal gland, medulla	(50)	(50)	(50)	(59)
Pheochromocytoma benign	1 (2%)			
Islets, pancreatic	(50)	(50)	(50)	(60)
Adenoma				1 (2%)
Pituitary gland	(49)	(48)	(48)	(55)
Pars distalis, adenoma	5 (10%)	4 (8%)	2 (4%)	1 (2%)
Pars distalis, carcinoma	1 (2%)			
Thyroid gland	(49)	(49)	(50)	(60)
Histiocytic sarcoma, metastatic, spleen	1 (2%)			
Follicular cell, adenoma	1 (2%)	3 (6%)	2 (4%)	2 (3%)
Follicular cell, adenoma, multiple	1 (2%)	1 (2%)		
Follicular cell, carcinoma	1 (2%)			
General Body System				
Tissue NOS	(1)			
Genital System				
Ovary	(50)	(49)	(50)	(58)
Cystadenoma	2 (4%)		1 (2%)	3 (5%)
Histiocytic sarcoma, metastatic, spleen	1 (2%)			
Histiocytic sarcoma, metastatic, uterus	1 (2%)			
Uterus	(50)	(50)	(50)	(60)
Histiocytic sarcoma	2 (4%)	2 (4%)		
Leiomyoma	1 (2%)			
Polyp stromal	1 (2%)	1 (2%)	3 (6%)	
Hematopoietic System				
Bone marrow	(50)	(50)	(50)	(60)
Lymph node	(49)	(50)	(50)	(57)
Carcinoma, metastatic, mammary gland	1 (2%)			
Carcinoma, metastatic, pancreas	1 (2%)			
Pancreatic, histiocytic sarcoma, metastatic, liver			1 (2%)	
Lymph node, bronchial	(25)	(32)	(31)	(30)
Carcinoma, metastatic, kidney		1 (3%)		
Histiocytic sarcoma, metastatic, spleen	1 (4%)			
Lymph node, mandibular	(42)	(40)	(43)	(46)
Histiocytic sarcoma, metastatic, spleen	2 (5%)			
Histiocytic sarcoma, metastatic, uterus	1 (2%)			
Lymph node, mediastinal	(18)	(17)	(14)	(13)
Carcinoma, metastatic, kidney		1 (6%)		
Histiocytic sarcoma, metastatic, spleen	1 (6%)			
Lymph node, mesenteric	(44)	(47)	(48)	(55)
Histiocytic sarcoma, metastatic, liver				1 (2%)
Histiocytic sarcoma, metastatic, spleen	3 (7%)			

TABLE B1
Summary of the Incidence of Neoplasms in Female Mice in the 2-Year Inhalation Study
of Methyl Bromide (continued)

	0 ppm	10 ppm	33 ppm	100 ppm
Hematopoietic System (continued)				
Spleen	(50)	(50)	(50)	(60)
Hemangiosarcoma		1 (2%)		1 (2%)
Hemangiosarcoma, marked			1 (2%)	
Hemangiosarcoma, moderate			1 (2%)	
Histiocytic sarcoma	3 (6%)			
Histiocytic sarcoma, metastatic, liver			1 (2%)	1 (2%)
Histiocytic sarcoma, metastatic, uterus	1 (2%)			
Thymus	(45)	(40)	(43)	(51)
Carcinoma, metastatic, pancreas	1 (2%)			
Hemangiosarcoma, metastatic, heart		1 (3%)		
Histiocytic sarcoma, metastatic, spleen	1 (2%)			
Thymoma NOS		2 (5%)		
Integumentary System				
Mammary gland	(38)	(35)	(38)	(51)
Adenocarcinoma	1 (3%)			
Carcinoma				1 (2%)
Skin	(50)	(50)	(50)	(60)
Fibrosarcoma		1 (2%)		
Subcutaneous tissue, fibrosarcoma	1 (2%)			
Tail, keratoacanthoma	1 (2%)			
Musculoskeletal System				
Bone	(50)	(50)	(50)	(60)
Osteosarcoma		1 (2%)		
Skeletal muscle				(1)
Sarcoma				1 (100%)
Nervous System				
Brain	(50)	(50)	(50)	(60)
Peripheral nerve	(49)	(50)	(50)	(59)
Respiratory System				
Lung	(50)	(50)	(50)	(60)
Alveolar/bronchiolar adenoma	3 (6%)	2 (4%)		6 (10%)
Alveolar/bronchiolar adenoma, multiple				1 (2%)
Alveolar/bronchiolar carcinoma	1 (2%)	2 (4%)	1 (2%)	1 (2%)
Carcinoma, metastatic, harderian gland				1 (2%)
Carcinoma, metastatic, liver		1 (2%)		
Carcinoma, metastatic, mammary gland				1 (2%)
Carcinoma, metastatic, pancreas	1 (2%)			
Fibrosarcoma, metastatic, skin		1 (2%)		
Histiocytic sarcoma, metastatic, liver				1 (2%)
Histiocytic sarcoma, metastatic, spleen	2 (4%)			
Histiocytic sarcoma, metastatic, uterus	1 (2%)			
Osteosarcoma, metastatic, bone		1 (2%)		1 (2%)

TABLE B1
Summary of the Incidence of Neoplasms in Female Mice in the 2-Year Inhalation Study
of Methyl Bromide (continued)

	0 ppm	10 ppm	33 ppm	100 ppm
Respiratory System (continued)				
Nose	(50)	(50)	(50)	(60)
Osteosarcoma, metastatic				1 (2%)
Trachea	(49)	(49)	(50)	(60)
Special Senses System				
Harderian gland	(1)	(1)		(1)
Adenoma	1 (100%)	1 (100%)		
Carcinoma				1 (100%)
Urinary System				
Kidney	(50)	(50)	(50)	(60)
Carcinoma, metastatic		1 (2%)		
Carcinoma, metastatic, pancreas	1 (2%)			
Histiocytic sarcoma, metastatic, liver			1 (2%)	1 (2%)
Histiocytic sarcoma, metastatic, spleen	1 (2%)			
Urinary bladder	(50)	(50)	(50)	(59)
Histiocytic sarcoma, metastatic, spleen	1 (2%)			
Systemic Lesions				
Multiple organs ^a	(50)	(50)	(50)	(60)
Histiocytic sarcoma	5 (10%)	2 (4%)	1 (2%)	1 (2%)
Lymphoma malignant lymphocytic			3 (6%)	1 (2%)
Lymphoma malignant mixed	4 (8%)	4 (8%)	5 (10%)	6 (10%)
Lymphoma malignant undifferentiated cell			1 (2%)	
Tumor Summary				
Total animals with primary neoplasms ^b	27	29	27	27
Total primary neoplasms	42	37	31	34
Total animals with benign neoplasms	16	16	15	18
Total benign neoplasms	23	19	16	20
Total animals with malignant neoplasms	16	15	15	14
Total malignant neoplasms	19	16	15	14
Total animals with secondary neoplasms	6	6	1	4
Total secondary neoplasms	29	10	3	9
Total animals with uncertain benign or malignant neoplasms		2		
Total uncertain neoplasms		2		

^a The number in parentheses is the number of animals with any tissue examined microscopically.

^b Primary neoplasms: all neoplasms except metastatic neoplasms

TABLE B2
Individual Animal Tumor Pathology of Female Mice in the 2-Year Inhalation Study
of Methyl Bromide: 0 ppm (continued)

Number of Days on Study	7 7	2 2 3	9 9 0 0 0 0 0 0 0 0 0 0 1 1 1 1 1 1 1 1 2 2 2 2 2 2
Carcass ID Number	1 1	4 5 2 2 3 3 4 5 6 8 9 3 5 5 5 6 6 6 6 2 3 3 4 4 6	7 1 6 8 3 6 9 2 1 9 0 0 7 8 9 2 4 7 8 7 2 4 2 5 0
	1 1		Total Tissues/Tumors
Endocrine System			
Adrenal gland	+	+	50
Adrenal gland, cortex	+	+	50
Adrenal gland, medulla	+	+	50
Pheochromocytoma benign		X	1
Islets, pancreatic	+	+	50
Parathyroid gland	+	+	45
Pituitary gland	+	+	49
Pars distalis, adenoma		X	5
Pars distalis, carcinoma			1
Thyroid gland	+	+	49
Histiocytic sarcoma, metastatic, spleen			1
Follicular cell, adenoma		X	1
Follicular cell, adenoma, multiple		X	1
Follicular cell, carcinoma			1
General Body System			
Tissue NOS			1
Genital System			
Ovary	+	+	50
Cystadenoma	X		2
Histiocytic sarcoma, metastatic, spleen			1
Histiocytic sarcoma, metastatic, uterus			1
Uterus	+	+	50
Histiocytic sarcoma		X	2
Leiomyoma			1
Polyp stromal		X	1

TABLE B2
Individual Animal Tumor Pathology of Female Mice in the 2-Year Inhalation Study
of Methyl Bromide: 33 ppm (continued)

Number of Days on Study	7 7	3 3	0 0 0 0 0 0 0 0 1 1 1 1 1 1 1 1 2 2 2 2 2 2 2 2 2
Carcass ID Number	4 4 4 5 5 5 5 5 4 5 5 5 5 5 5 5 4 4 4 4 5 5 5 5 5	8 8 9 0 1 1 1 2 8 1 1 1 2 2 2 2 8 8 9 9 0 1 1 2 3	5 7 2 8 1 3 4 0 9 6 7 8 1 6 7 8 2 6 1 3 1 5 9 2 0
	1 1		Total Tissues/Tumors
Hematopoietic System			
Bone marrow	+	+	50
Lymph node	+	+	50
Pancreatic, histiocytic sarcoma, metastatic, liver			1
Lymph node, bronchial	+	M	31
Lymph node, mandibular	+	+	43
Lymph node, mediastinal	M	+	14
Lymph node, mesenteric	+	+	48
Spleen	+	+	50
Hemangiosarcoma, marked			1
Hemangiosarcoma, moderate		X	1
Histiocytic sarcoma, metastatic, liver			1
Thymus	M	+	43
Integumentary System			
Mammary gland	M	+	38
Skin	+	+	50
Musculoskeletal System			
Bone	+	+	50
Nervous System			
Brain	+	+	50
Peripheral nerve	+	+	50
Spinal cord	+	+	50
Respiratory System			
Larynx	+	+	50
Lung	+	+	50
Alveolar/bronchiolar carcinoma			1
Nose	+	+	50
Trachea	+	+	50
Special Senses System			
None			
Urinary System			
Kidney	+	+	50
Histiocytic sarcoma, metastatic, liver			1
Urinary bladder	+	+	50
Systemic Lesions			
Multiple organs	+	+	50
Histiocytic sarcoma			1
Lymphoma malignant lymphocytic			3
Lymphoma malignant mixed	X	X	5
Lymphoma malignant undifferentiated cell type			1

TABLE B3
Statistical Analysis of Primary Neoplasms in Female Mice in the 2-Year Inhalation Study of Methyl Bromide

	0 ppm	10 ppm	33 ppm	100 ppm
Liver: Hepatocellular Adenoma				
Overall rates ^a	6/51 (12%)	7/50 (14%)	7/50 (14%)	5/62 (8%)
Adjusted rates ^b	16.7%	17.1%	15.6%	11.9%
Terminal rates ^c	6/36 (17%)	7/41 (17%)	7/45 (16%)	4/40 (10%)
First incidence (days)	727 (T)	727 (T)	727 (T)	578
Life table tests ^d	P=0.337N	P=0.601	P=0.567N	P=0.429N
Logistic regression tests ^d	P=0.361N	P=0.601	P=0.567N	P=0.467N
Cochran-Armitage test ^d	P=0.223N			
Fisher exact test ^d		P=0.485	P=0.485	P=0.364N
Liver: Hepatocellular Carcinoma				
Overall rates	4/51 (8%)	4/50 (8%)	2/50 (4%)	1/62 (2%)
Adjusted rates	10.7%	9.8%	4.4%	2.5%
Terminal rates	3/36 (8%)	4/41 (10%)	2/45 (4%)	1/40 (3%)
First incidence (days)	708	727 (T)	727 (T)	727 (T)
Life table tests	P=0.098N	P=0.576N	P=0.246N	P=0.156N
Logistic regression tests	P=0.105N	P=0.610N	P=0.269N	P=0.168N
Cochran-Armitage test	P=0.072N			
Fisher exact test		P=0.631	P=0.348N	P=0.127N
Liver: Hepatocellular Adenoma or Carcinoma				
Overall rates	10/51 (20%)	11/50 (22%)	8/50 (16%)	6/62 (10%)
Adjusted rates	26.9%	26.8%	17.8%	14.4%
Terminal rates	9/36 (25%)	11/41 (27%)	8/45 (18%)	5/40 (13%)
First incidence (days)	708	727 (T)	727 (T)	578
Life table tests	P=0.097N	P=0.567N	P=0.217N	P=0.152N
Logistic regression tests	P=0.113N	P=0.577	P=0.249N	P=0.179N
Cochran-Armitage test	P=0.049N			
Fisher exact test		P=0.480	P=0.416N	P=0.109N
Lung: Alveolar/bronchiolar Adenoma				
Overall rates	3/51 (6%)	2/50 (4%)	0/50 (0%)	7/62 (11%)
Adjusted rates	8.3%	4.7%	0.0%	17.0%
Terminal rates	3/36 (8%)	1/41 (2%)	0/45 (0%)	6/40 (15%)
First incidence (days)	727 (T)	643	- ^e	658
Life table tests	P=0.027	P=0.449N	P=0.085N	P=0.200
Logistic regression tests	P=0.027	P=0.486N	P=0.085N	P=0.172
Cochran-Armitage test	P=0.057			
Fisher exact test		P=0.509N	P=0.125N	P=0.253
Lung: Alveolar/bronchiolar Adenoma or Carcinoma				
Overall rates	4/51 (8%)	4/50 (8%)	1/50 (2%)	7/62 (11%)
Adjusted rates	10.8%	9.4%	2.2%	17.0%
Terminal rates	3/36 (8%)	3/41 (7%)	1/45 (2%)	6/40 (15%)
First incidence (days)	720	643	727 (T)	658
Life table tests	P=0.143	P=0.577N	P=0.123N	P=0.319
Logistic regression tests	P=0.138	P=0.621N	P=0.132N	P=0.282
Cochran-Armitage test	P=0.236			
Fisher exact test		P=0.631	P=0.187N	P=0.387

TABLE B3
Statistical Analysis of Primary Neoplasms in Female Mice in the 2-Year Inhalation Study
of Methyl Bromide (continued)

	0 ppm	10 ppm	33 ppm	100 ppm
Ovary: Cystadenoma				
Overall rates	2/51 (4%)	0/49 (0%)	1/50 (2%)	3/60 (5%)
Adjusted rates	5.6%	0.0%	2.2%	7.5%
Terminal rates	2/36 (6%)	0/40 (0%)	1/45 (2%)	3/40 (8%)
First incidence (days)	727 (T)	–	727 (T)	727 (T)
Life table tests	P=0.193	P=0.215N	P=0.422N	P=0.548
Logistic regression tests	P=0.193	P=0.215N	P=0.422N	P=0.548
Cochran-Armitage test	P=0.247			
Fisher exact test		P=0.258N	P=0.508N	P=0.577
Pituitary Gland (Pars distalis): Adenoma				
Overall rates	5/49 (10%)	4/48 (8%)	2/48 (4%)	1/57 (2%)
Adjusted rates	13.5%	9.3%	4.2%	2.6%
Terminal rates	4/36 (11%)	2/41 (5%)	0/44 (0%)	1/39 (3%)
First incidence (days)	720	643	681	727 (T)
Life table tests	P=0.072N	P=0.434N	P=0.153N	P=0.088N
Logistic regression tests	P=0.064N	P=0.491N	P=0.191N	P=0.098N
Cochran-Armitage test	P=0.051N			
Fisher exact test		P=0.513N	P=0.226N	P=0.072N
Pituitary Gland (Pars Distalis or Unspecified Site): Adenoma or Carcinoma				
Overall rates	6/49 (12%)	4/48 (8%)	2/48 (4%)	1/57 (2%)
Adjusted rates	16.2%	9.3%	4.2%	2.6%
Terminal rates	5/36 (14%)	2/41 (5%)	0/44 (0%)	1/39 (3%)
First incidence (days)	720	643	681	727 (T)
Life table tests	P=0.047N	P=0.306N	P=0.087N	P=0.048N
Logistic regression tests	P=0.042N	P=0.358N	P=0.111N	P=0.054N
Cochran-Armitage test	P=0.032N			
Fisher exact test		P=0.383N	P=0.141N	P=0.036N
Spleen: Histiocytic Sarcoma				
Overall rates	3/51 (6%)	0/50 (0%)	0/50 (0%)	0/62 (0%)
Adjusted rates	7.3%	0.0%	0.0%	0.0%
Terminal rates	1/36 (3%)	0/41 (0%)	0/45 (0%)	0/40 (0%)
First incidence (days)	500	–	–	–
Life table tests	P=0.131N	P=0.111N	P=0.098N	P=0.114N
Logistic regression tests	P=0.096N	P=0.134N	P=0.153N	P=0.089N
Cochran-Armitage test	P=0.115N			
Fisher exact test		P=0.125N	P=0.125N	P=0.089N
Thymus: Thymoma NOS				
Overall rates	0/46 (0%)	2/40 (5%)	0/43 (0%)	0/52 (0%)
Adjusted rates	0.0%	5.4%	0.0%	0.0%
Terminal rates	0/33 (0%)	1/31 (3%)	0/38 (0%)	0/32 (0%)
First incidence (days)	–	643	–	–
Life table tests	P=0.369N	P=0.238	–	–
Logistic regression tests	P=0.350N	P=0.207	–	–
Cochran-Armitage test	P=0.337N			
Fisher exact test		P=0.213	–	–

TABLE B3
Statistical Analysis of Primary Neoplasms in Female Mice in the 2-Year Inhalation Study
of Methyl Bromide (continued)

	0 ppm	10 ppm	33 ppm	(100 ppm)
Thyroid Gland (Follicular cell): Adenoma				
Overall rates	2/50 (4%)	4/49 (8%)	2/50 (4%)	2/61 (3%)
Adjusted rates	5.6%	9.8%	4.4%	5.0%
Terminal rates	2/36 (6%)	4/41 (10%)	2/45 (4%)	2/40 (5%)
First incidence (days)	727 (T)	727 (T)	727 (T)	727 (T)
Life table tests	P=0.418N	P=0.398	P=0.612N	P=0.657N
Logistic regression tests	P=0.418N	P=0.398	P=0.612N	P=0.657N
Cochran-Armitage test	P=0.336N			
Fisher exact test		P=0.329	P=0.691N	P=0.612N
Thyroid Gland (Follicular cell): Adenoma or Carcinoma				
Overall rates	3/50 (6%)	4/49 (8%)	2/50 (4%)	2/61 (3%)
Adjusted rates	8.3%	9.8%	4.4%	5.0%
Terminal rates	3/36 (8%)	4/41 (10%)	2/45 (4%)	2/40 (5%)
First incidence (days)	727 (T)	727 (T)	727 (T)	727 (T)
Life table tests	P=0.311N	P=0.571	P=0.399N	P=0.452N
Logistic regression tests	P=0.311N	P=0.571	P=0.399N	P=0.452N
Cochran-Armitage test	P=0.241N			
Fisher exact test		P=0.489	P=0.500N	P=0.406N
Uterus: Polyp Stromal				
Overall rates	1/51 (2%)	1/50 (2%)	3/50 (6%)	0/62 (0%)
Adjusted rates	2.8%	2.4%	6.7%	0.0%
Terminal rates	1/36 (3%)	1/41 (2%)	3/45 (7%)	0/40 (0%)
First incidence (days)	727 (T)	727 (T)	727 (T)	-
Life table tests	P=0.321N	P=0.733N	P=0.388	P=0.479N
Logistic regression tests	P=0.321N	P=0.733N	P=0.388	P=0.479N
Cochran-Armitage test	P=0.276N			
Fisher exact test		P=0.748	P=0.301	P=0.451N
All Organs (Malignant Lymphoma): Lymphocytic, Mixed, or Undifferentiated Cell Type				
Overall rates	4/51 (8%)	4/50 (8%)	9/50 (18%)	7/62 (11%)
Adjusted rates	9.1%	9.3%	19.1%	14.9%
Terminal rates	1/36 (3%)	3/41 (7%)	7/45 (16%)	3/40 (8%)
First incidence (days)	430	622	640	233
Life table tests	P=0.237	P=0.594N	P=0.212	P=0.313
Logistic regression tests	P=0.423	P=0.590	P=0.063	P=0.455
Cochran-Armitage test	P=0.369			
Fisher exact test		P=0.631	P=0.110	P=0.387
All Organs: Benign Tumors				
Overall rates	16/51 (31%)	16/50 (32%)	15/50 (30%)	18/62 (29%)
Adjusted rates	42.0%	36.2%	31.1%	42.7%
Terminal rates	14/36 (39%)	13/41 (32%)	12/45 (27%)	16/40 (40%)
First incidence (days)	707	577	596	578
Life table tests	P=0.407	P=0.424N	P=0.244N	P=0.555
Logistic regression tests	P=0.392	P=0.522N	P=0.343N	P=0.468
Cochran-Armitage test	P=0.414N			
Fisher exact test		P=0.558	P=0.526N	P=0.474N

TABLE B3
Statistical Analysis of Primary Neoplasms in Female Mice in the 2-Year Inhalation Study
of Methyl Bromide (continued)

	0 ppm	10 ppm	33 ppm	100 ppm
All Organs: Malignant Tumors				
Overall rates	16/51 (31%)	15/50 (30%)	15/50 (30%)	14/62 (23%)
Adjusted rates	35.1%	32.9%	31.9%	28.4%
Terminal rates	7/36 (19%)	11/41 (27%)	13/45 (29%)	6/40 (15%)
First incidence (days)	430	428	640	233
Life table tests	P=0.362N	P=0.387N	P=0.280N	P=0.350N
Logistic regression tests	P=0.146N	P=0.559N	P=0.569N	P=0.205N
Cochran-Armitage test	P=0.153N			
Fisher exact test		P=0.526N	P=0.526N	P=0.201N
All Organs: Benign and Malignant Tumors				
Overall rates	27/51 (53%)	29/50 (58%)	27/50 (54%)	27/62 (44%)
Adjusted rates	58.6%	60.3%	54.0%	55.8%
Terminal rates	17/36 (47%)	22/41 (54%)	22/45 (49%)	19/40 (48%)
First incidence (days)	430	428	596	233
Life table tests	P=0.407N	P=0.503N	P=0.230N	P=0.419N
Logistic regression tests	P=0.206N	P=0.403	P=0.561N	P=0.356N
Cochran-Armitage test	P=0.090N			
Fisher exact test		P=0.378	P=0.537	P=0.210N

(T) Terminal sacrifice

^a Number of tumor-bearing animals/number of animals examined. Denominator is number of animals microscopically examined for adrenal gland, bone marrow, brain, clitoral gland, epididymis, gallbladder (mouse), heart, kidney, larynx, liver, lung, nose, ovary, pancreas, parathyroid gland, pituitary gland, preputial gland, prostate gland, salivary gland, spleen, testes, thyroid gland, and urinary bladder; for other tissues, denominator is number of animals necropsied.

^b Kaplan-Meier estimated tumor incidence at the end of the study after adjustment for intercurrent mortality

^c Observed incidence at terminal kill

^d Beneath the control incidence are the P values associated with the trend test. Beneath the dosed group incidence are the P values corresponding to pairwise comparisons between the controls and that dosed group. The life table analysis regards tumors in animals dying prior to terminal kill as being (directly or indirectly) the cause of death. The logistic regression tests regard these lesions as nonfatal. The Cochran-Armitage and Fisher exact tests compare directly the overall incidence rates. For all tests, a negative trend or a lower incidence in a dose group is indicated by N.

^e Not applicable; no tumors in animal group

TABLE B4
Summary of the Incidence of Nonneoplastic Lesions in Female Mice in the 2-Year Inhalation Study of Methyl Bromide

	0 ppm	10 ppm	33 ppm	100 ppm
Disposition Summary				
Animals initially in study	71	70	70	70
6-Month interim evaluation	10	10	10	8
15-Month interim evaluation	9	10	10	0
Early deaths				
Natural deaths	7	3	1	6
Moribund kills	9	6	4	16
Survivors				
Terminal sacrifice	36	41	45	40
Animals examined microscopically	50	50	50	60
Alimentary System				
Gallbladder	(46)	(49)	(49)	(58)
Diverticulum		1 (2%)		
Infiltration cellular, lymphocytic	2 (4%)	7 (14%)	4 (8%)	2 (3%)
Intestine large, cecum	(50)	(50)	(50)	(58)
Intestine small, ileum	(49)	(50)	(49)	(58)
Hyperplasia, lymphoid	1 (2%)			
Intestine small, jejunum	(48)	(49)	(50)	(58)
Hyperplasia, lymphoid		1 (2%)		
Liver	(50)	(50)	(50)	(60)
Basophilic focus	3 (6%)	1 (2%)	1 (2%)	
Clear cell focus	3 (6%)	5 (10%)	1 (2%)	5 (8%)
Cyst			1 (2%)	
Eosinophilic focus	1 (2%)	1 (2%)	1 (2%)	
Infiltration cellular, lymphocytic	11 (22%)	18 (36%)	7 (14%)	10 (17%)
Inflammation	7 (14%)	1 (2%)	6 (12%)	1 (2%)
Mineralization			1 (2%)	
Mixed cell focus	2 (4%)		2 (4%)	1 (2%)
Necrosis			1 (2%)	1 (2%)
Thrombus	1 (2%)			
Bile duct, hyperplasia		1 (2%)		
Hepatocyte, vacuolization cytoplasmic			2 (4%)	3 (5%)
Mesentery	(2)	(2)	(3)	(1)
Cyst	1 (50%)		1 (33%)	
Fat, necrosis	1 (50%)	2 (100%)	2 (67%)	1 (100%)
Pancreas	(50)	(50)	(50)	(60)
Infiltration cellular, lymphocytic	19 (38%)	24 (48%)	17 (34%)	16 (27%)
Acinus, atrophy	1 (2%)	2 (4%)	4 (8%)	2 (3%)
Acinus, cyst		1 (2%)		
Acinus, inflammation, chronic active				1 (2%)
Duct, dilatation			1 (2%)	
Fat, necrosis				1 (2%)
Salivary glands	(49)	(49)	(50)	(60)
Atrophy				1 (2%)
Infiltration cellular, lymphocytic	35 (71%)	25 (51%)	21 (42%)	30 (50%)

TABLE B4
Summary of the Incidence of Nonneoplastic Lesions in Female Mice in the 2-Year Inhalation Study
of Methyl Bromide (continued)

	0 ppm	10 ppm	33 ppm	100 ppm
Alimentary System (continued)				
Stomach, forestomach	(50)	(50)	(49)	(60)
Epithelium, hyperplasia, focal				1 (2%)
Ulcer	1 (2%)			
Stomach, glandular	(50)	(50)	(49)	(60)
Infiltration cellular, lymphocytic	1 (2%)			1 (2%)
Mineralization	2 (4%)			
Tooth			(2)	(2)
Dysplasia			2 (100%)	2 (100%)
Cardiovascular System				
Heart	(50)	(50)	(50)	(59)
Cardiomyopathy, chronic	2 (4%)	4 (8%)	2 (4%)	34 (58%)
Degeneration	1 (2%)			7 (12%)
Embolus bacterial		1 (2%)		
Inflammation, acute		1 (2%)		
Inflammation, chronic active				2 (3%)
Mineralization		1 (2%)	1 (2%)	1 (2%)
Polyarteritis	2 (4%)	2 (4%)		1 (2%)
Valve, cyst				1 (2%)
Endocrine System				
Adrenal gland	(50)	(50)	(50)	(59)
Amyloid deposition	3 (6%)	5 (10%)	4 (8%)	4 (7%)
Hematopoietic cell proliferation		1 (2%)		
Pigmentation	9 (18%)	6 (12%)	4 (8%)	3 (5%)
Spindle cell, hyperplasia	47 (94%)	49 (98%)	50 (100%)	56 (95%)
Adrenal gland, cortex	(50)	(50)	(50)	(59)
Cyst		1 (2%)		1 (2%)
Hyperplasia	3 (6%)	3 (6%)	3 (6%)	3 (5%)
Hypertrophy	2 (4%)	2 (4%)	1 (2%)	
Vacuolization cytoplasmic	4 (8%)	2 (4%)	2 (4%)	
Spindle cell, hyperplasia		1 (2%)		
Adrenal gland, medulla	(50)	(50)	(50)	(59)
Hyperplasia	4 (8%)	1 (2%)	3 (6%)	1 (2%)
Islets, pancreatic	(50)	(50)	(50)	(60)
Hyperplasia		2 (4%)	1 (2%)	2 (3%)
Parathyroid gland	(45)	(47)		
Cyst	3 (7%)	1 (2%)		
Pituitary gland	(49)	(48)	(48)	(55)
Angiectasis	2 (4%)	2 (4%)	8 (17%)	
Hyperplasia			1 (2%)	
Pars distalis, cyst		1 (2%)	2 (4%)	
Pars distalis, hyperplasia	6 (12%)	5 (10%)	1 (2%)	2 (4%)
Thyroid gland	(49)	(49)	(50)	(60)
Infiltration cellular, lymphocytic	2 (4%)	4 (8%)		
Polyarteritis	1 (2%)			1 (2%)
Follicular cell, hyperplasia	7 (14%)	10 (20%)	6 (12%)	6 (10%)

TABLE B4
Summary of the Incidence of Nonneoplastic Lesions in Female Mice in the 2-Year Inhalation Study
of Methyl Bromide (continued)

	0 ppm	10 ppm	33 ppm	100 ppm
General Body System				
None				
Genital System				
Ovary	(50)	(49)	(50)	(58)
Cyst	8 (16%)	10 (20%)	10 (20%)	13 (22%)
Hemorrhage			1 (2%)	
Infiltration cellular, lymphocytic		2 (4%)	1 (2%)	
Inflammation				1 (2%)
Mineralization			1 (2%)	
Pigmentation	2 (4%)			
Uterus	(50)	(50)	(50)	(60)
Adenomyosis				1 (2%)
Angiectasis		2 (4%)	1 (2%)	
Atrophy				1 (2%)
Hemorrhage		1 (2%)		
Thrombus				1 (2%)
Infiltration cellular, lymphocytic		1 (2%)		
Endometrium, hyperplasia, cystic	45 (90%)	49 (98%)	49 (98%)	51 (85%)
Endothelium, hyperplasia, cystic				1 (2%)
Vagina				(1)
Inflammation, suppurative				1 (100%)
Hematopoietic System				
Bone marrow	(50)	(50)	(50)	(60)
Myelofibrosis	33 (66%)	33 (66%)	35 (70%)	43 (72%)
Lymph node	(49)	(50)	(50)	(57)
Iliac, hyperplasia	1 (2%)	2 (4%)		
Pancreatic, hyperplasia				1 (2%)
Lymph node, bronchial	(25)	(32)	(31)	(30)
Hyperplasia		1 (3%)	3 (10%)	2 (7%)
Lymph node, mandibular	(42)	(40)	(43)	(46)
Hyperplasia	1 (2%)	3 (8%)		1 (2%)
Lymph node, mediastinal	(18)	(17)	(14)	(13)
Hyperplasia	1 (6%)	1 (6%)	1 (7%)	
Lymph node, mesenteric	(44)	(47)	(48)	(55)
Angiectasis			1 (2%)	1 (2%)
Edema	1 (2%)	1 (2%)		
Hyperplasia		3 (6%)	2 (4%)	1 (2%)
Spleen	(50)	(50)	(50)	(60)
Atrophy		1 (2%)	1 (2%)	4 (7%)
Congestion	1 (2%)			
Fibrosis		1 (2%)		
Hematopoietic cell proliferation	2 (4%)	3 (6%)	3 (6%)	1 (2%)
Hemorrhage				1 (2%)
Hyperplasia, lymphoid	6 (12%)	10 (20%)	4 (8%)	3 (5%)
Necrosis		1 (2%)		
Thymus	(45)	(40)	(43)	(51)
Atrophy	1 (2%)	1 (3%)		4 (8%)
Hyperplasia			1 (2%)	1 (2%)
Necrosis				2 (4%)

TABLE B4
Summary of the Incidence of Nonneoplastic Lesions in Female Mice in the 2-Year Inhalation Study
of Methyl Bromide (continued)

	0 ppm	10 ppm	33 ppm	100 ppm
Integumentary System				
Mammary gland	(38)	(35)	(38)	(51)
Hyperplasia, cystic	1 (3%)	4 (11%)	2 (5%)	1 (2%)
Skin	(50)	(50)	(50)	(60)
Alopecia	5 (10%)	2 (4%)	3 (6%)	5 (8%)
Cyst				3 (5%)
Infiltration cellular, lymphocytic	2 (4%)	1 (2%)		2 (3%)
Musculoskeletal System				
Bone	(50)	(50)	(50)	(60)
Sternum, dysplasia		2 (4%)	2 (4%)	9 (15%)
Nervous System				
Brain	(50)	(50)	(50)	(60)
Gliosis				1 (2%)
Hemorrhage		1 (2%)		
Infiltration cellular, lymphocytic		1 (2%)	2 (4%)	1 (2%)
Inflammation		1 (2%)		3 (5%)
Cerebellum, degeneration				11 (18%)
Cerebrum, degeneration				2 (3%)
Thalamus, mineralization	28 (56%)	30 (60%)	25 (50%)	15 (25%)
Ventricle, dilatation		1 (2%)	1 (2%)	3 (5%)
Ventricle, mineralization			1 (2%)	
Peripheral nerve	(49)	(50)	(50)	(59)
Degeneration		1 (2%)		
Spinal cord	(49)	(50)	(50)	(59)
Ectopic tissue				
Infiltration cellular, lymphocytic	1 (2%)			
Mineralization	1 (2%)			
Meninges, infiltration cellular, lymphocytic		1 (2%)		
Respiratory System				
Larynx	(49)	(47)	(50)	(58)
Lung	(50)	(50)	(50)	(60)
Adenomatosis			1 (2%)	
Hyperplasia, lymphoid			2 (4%)	
Infiltration cellular, lymphocytic	1 (2%)	1 (2%)		2 (3%)
Infiltration cellular, histiocytic		1 (2%)	1 (2%)	1 (2%)
Mineralization				
Interstitial, inflammation, acute, multifocal				1 (2%)
Pleura, inflammation, chronic active				1 (2%)
Alveolar epithelium, hyperplasia		1 (2%)		

TABLE B4
Summary of the Incidence of Nonneoplastic Lesions in Female Mice in the 2-Year Inhalation Study
of Methyl Bromide (continued)

	0 ppm	10 ppm	33 ppm	100 ppm
Respiratory System (continued)				
Nose	(50)	(50)	(50)	(60)
Exudate			2 (4%)	3 (5%)
Inflammation, acute		1 (2%)	2 (4%)	1 (2%)
Inflammation, chronic		2 (4%)		
Inflammation, suppurative				1 (2%)
Nasolacrimal duct, inflammation				1 (2%)
Olfactory epithelium, metaplasia				5 (8%)
Olfactory epithelium, necrosis				1 (2%)
Trachea	(49)	(49)	(50)	(60)
Special Senses System				
None				
Urinary System				
Kidney	(50)	(50)	(50)	(60)
Hydronephrosis		1 (2%)		
Infarct	1 (2%)			1 (2%)
Infiltration cellular, lymphocytic	32 (64%)	36 (72%)	32 (64%)	34 (57%)
Inflammation, chronic	1 (2%)			
Inflammation, suppurative		1 (2%)		
Metaplasia, osseous	2 (4%)		1 (2%)	1 (2%)
Polyarteritis	1 (2%)			
Cortex, cyst				3 (5%)
Renal tubule, bacterium		1 (2%)		
Renal tubule, casts protein		9 (18%)	5 (10%)	3 (5%)
Renal tubule, mineralization	2 (4%)	1 (2%)		
Renal tubule, pigmentation			1 (2%)	
Urinary bladder	(50)	(50)	(50)	(59)
Infiltration cellular, lymphocytic	22 (44%)	22 (44%)	25 (50%)	22 (37%)
Polyarteritis	1 (2%)			

APPENDIX C

ORGAN WEIGHTS AND ORGAN-WEIGHT-TO-BODY-WEIGHT RATIOS

TABLE C1	Organ Weights for Rats in the 13-Week Inhalation Studies of Methyl Bromide	134
TABLE C2	Organ-Weight-to-Body-Weight Ratios for Rats in the 13-Week Inhalation Studies of Methyl Bromide	135
TABLE C3	Organ Weights for Mice in the 13-Week Inhalation Studies of Methyl Bromide	136
TABLE C4	Organ-Weight-to-Body-Weight Ratios for Mice in the 13-Week Inhalation Studies of Methyl Bromide	137
TABLE C5	Organ Weights for Mice at the 6-Month Interim Evaluation of the 2-Year Inhalation Studies of Methyl Bromide	138
TABLE C6	Organ-Weight-to-Body-Weight Ratios for Mice at the 6-Month Interim Evaluation of the 2-Year Inhalation Studies of Methyl Bromide	139
TABLE C7	Organ Weights for Mice at the 15-Month Interim Evaluation of the 2-Year Inhalation Studies of Methyl Bromide	140
TABLE C8	Organ-Weight-to-Body-Weight Ratios for Mice at the 15-Month Interim Evaluation of the 2-Year Inhalation Studies of Methyl Bromide	141
TABLE C9	Organ Weights for Mice at the Terminal Evaluation of the 2-Year Inhalation Studies of Methyl Bromide	142
TABLE C10	Organ-Weight-to-Body-Weight Ratios for Mice at the Terminal Evaluation of the 2-Year Inhalation Studies of Methyl Bromide	143

TABLE C1
Organ Weights for Rats in the 13-Week Inhalation Studies of Methyl Bromide^a

Organ	0 ppm	30 ppm	60 ppm	120 ppm
Male				
Number weighed ^b	10	10	9	10
Necropsy body wt	306 ± 7	325 ± 5	293 ± 8	268 ± 9**
Adrenal gland	0.06 ± 0.01	0.06 ± 0.00	0.06 ± 0.00	0.06 ± 0.01
Brain	1.90 ± 0.02	1.87 ± 0.03	1.83 ± 0.02	1.74 ± 0.03**
Heart	0.96 ± 0.03	1.02 ± 0.04	0.95 ± 0.03	0.91 ± 0.03
Kidney	1.15 ± 0.04	1.23 ± 0.03	1.10 ± 0.04	1.05 ± 0.04
Liver	11.60 ± 0.35	13.06 ± 0.29	11.30 ± 0.46	9.76 ± 0.40*
Lung	1.31 ± 0.07 ^c	1.40 ± 0.05	1.31 ± 0.04	1.22 ± 0.05
Spleen	0.65 ± 0.01	0.65 ± 0.01	0.62 ± 0.02	0.59 ± 0.01**
L. testis	1.36 ± 0.07	1.47 ± 0.02	1.41 ± 0.03	1.44 ± 0.03
R. testis	1.45 ± 0.02	1.43 ± 0.02	1.37 ± 0.03	1.40 ± 0.04
Female				
Number weighed	10	10	10	10
Necropsy body wt	191 ± 3	184 ± 3	179 ± 4**	166 ± 4**
Adrenal gland	0.07 ± 0.00 ^c	0.08 ± 0.01	0.07 ± 0.00	0.08 ± 0.00
Brain	1.77 ± 0.02	1.75 ± 0.02	1.75 ± 0.01	1.65 ± 0.02**
Heart	0.68 ± 0.02	0.67 ± 0.02	0.67 ± 0.02	0.72 ± 0.02
Kidney	0.74 ± 0.02	0.71 ± 0.01	0.69 ± 0.01	0.69 ± 0.02
Liver	6.36 ± 0.15	6.39 ± 0.18	6.30 ± 0.18	6.01 ± 0.18
Lung	0.98 ± 0.02	0.97 ± 0.02	0.94 ± 0.02 ^c	0.91 ± 0.02*
Spleen	0.47 ± 0.02	0.46 ± 0.01	0.46 ± 0.01	0.46 ± 0.01

* Significantly different ($P \leq 0.05$) from the control group by Dunn's or Shirley's test

** $P \leq 0.01$

^a Organ weights are given in grams (mean ± standard error).

^b Except where noted

^c n=9

TABLE C2
Organ-Weight-to-Body-Weight Ratios for Rats in the 13-Week Inhalation Studies of Methyl Bromide^a

Organ	0 ppm	30 ppm	60 ppm	120 ppm
Male				
Number weighed ^b	10	10	9	10
Necropsy body wt	306 ± 7	325 ± 5	293 ± 8	268 ± 9**
Adrenal gland	0.20 ± 0.02	0.18 ± 0.01	0.19 ± 0.02	0.23 ± 0.02
Brain	6.2 ± 0.12	5.8 ± 0.11	6.3 ± 0.13	6.5 ± 0.22
Heart	3.2 ± 0.06	3.1 ± 0.10	3.3 ± 0.11	3.4 ± 0.11
Kidney	3.8 ± 0.06	3.8 ± 0.05	3.8 ± 0.05	3.9 ± 0.05
Liver	37.9 ± 0.41	40.2 ± 0.35	38.5 ± 0.76	36.4 ± 0.39
Lung	4.3 ± 0.19 ^c	4.3 ± 0.13	4.5 ± 0.10	4.5 ± 0.10
Spleen	2.2 ± 0.06	2.0 ± 0.04	2.1 ± 0.06	2.2 ± 0.07
L. testis	4.4 ± 0.20	4.5 ± 0.07	4.8 ± 0.09*	5.4 ± 0.08**
R. testis	4.7 ± 0.12	4.4 ± 0.06	4.7 ± 0.05	5.3 ± 0.15*
Female				
Number weighed	10	10	10	10
Necropsy body wt	191 ± 3	184 ± 3	179 ± 4**	166 ± 4**
Adrenal gland	0.39 ± 0.02 ^c	0.41 ± 0.03	0.39 ± 0.03	0.45 ± 0.02
Brain	9.3 ± 0.16	9.5 ± 0.10	9.8 ± 0.17*	10.0 ± 0.14**
Heart	3.6 ± 0.09	3.6 ± 0.11	3.8 ± 0.11	4.3 ± 0.15**
Kidney	3.9 ± 0.10	3.9 ± 0.06	3.9 ± 0.06	4.2 ± 0.07**
Liver	33.3 ± 0.44	34.7 ± 0.62	35.1 ± 0.43*	36.2 ± 0.78**
Lung	5.1 ± 0.08	5.3 ± 0.09	5.2 ± 0.09 ^c	5.5 ± 0.17*
Spleen	2.5 ± 0.06	2.5 ± 0.06	2.6 ± 0.10	2.8 ± 0.08*

* Significantly different ($P \leq 0.05$) from the control group by Dunn's or Shirley's test

** $P \leq 0.01$

^a Organ-weight-to-body-weight ratios are given as mg organ weight/g body weight (mean ± standard error).

^b Except where noted

^c n=9

TABLE C3
Organ Weights for Mice in the 13-Week Inhalation Studies of Methyl Bromide^a

Organ	0 ppm		10 ppm		20 ppm		40 ppm		80 ppm		120 ppm	
Male												
Number weighed ^b	10		10		10		10		8		10	
Necropsy body wt	29.0 ± 0.45		30.1 ± 0.32		28.3 ± 0.70		28.7 ± 0.69		27.9 ± 0.85		25.5 ± 0.66**	
Brain	0.46 ± 0.01		0.47 ± 0.01		0.46 ± 0.01		0.46 ± 0.01		0.45 ± 0.01		0.43 ± 0.01**	
Heart	0.17 ± 0.01		0.19 ± 0.01		0.16 ± 0.01		0.17 ± 0.01		0.17 ± 0.01		0.15 ± 0.01*	
Kidney	0.28 ± 0.01		0.28 ± 0.01		0.26 ± 0.01		0.27 ± 0.01		0.28 ± 0.01		0.23 ± 0.01**	
Liver	1.82 ± 0.04		1.83 ± 0.05		1.66 ± 0.08		1.42 ± 0.06**		1.62 ± 0.10**		1.51 ± 0.10**	
Lung	0.18 ± 0.01		0.18 ± 0.01		0.18 ± 0.01		0.18 ± 0.01		0.19 ± 0.01		0.17 ± 0.01	
L. testis	0.11 ± 0.00		0.11 ± 0.00 ^c		0.11 ± 0.01		0.10 ± 0.01		0.11 ± 0.00		0.11 ± 0.01	
R. testis	0.11 ± 0.00		0.12 ± 0.00		- ^d		0.11 ± 0.00		-		0.12 ± 0.00	
Thymus	0.04 ± 0.01		0.04 ± 0.00		0.04 ± 0.00		0.04 ± 0.01		0.05 ± 0.01		0.05 ± 0.01	
Female												
Number weighed	10		10		10		10		8		10	
Necropsy body wt	23.1 ± 0.36		23.5 ± 0.34		23.5 ± 0.29		23.8 ± 0.41		23.8 ± 0.44		23.3 ± 0.24	
Brain	0.48 ± 0.00		0.47 ± 0.01		0.49 ± 0.01		0.47 ± 0.01		0.48 ± 0.00		0.44 ± 0.01**	
Heart	0.13 ± 0.01		0.13 ± 0.01		0.14 ± 0.01		0.13 ± 0.00		0.15 ± 0.01		0.14 ± 0.00	
Kidney	0.18 ± 0.00		0.18 ± 0.01		0.18 ± 0.01		0.18 ± 0.00		0.19 ± 0.00		0.19 ± 0.01	
Liver	1.27 ± 0.03		1.37 ± 0.04*		1.23 ± 0.02		1.36 ± 0.04		1.32 ± 0.04		1.45 ± 0.03*	
Lung	0.18 ± 0.01		0.19 ± 0.01		0.18 ± 0.01		0.18 ± 0.00		0.18 ± 0.01		0.20 ± 0.01	
Thymus	0.05 ± 0.00		0.04 ± 0.00		0.05 ± 0.00		0.06 ± 0.01		0.05 ± 0.01		0.05 ± 0.01	

* Significantly different ($P \leq 0.05$) from the control group by Dunn's or Shirley's test

** $P \leq 0.01$

^a Organ weights are given in grams (mean ± standard error).

^b Except where noted

^c n=9

^d Tissue not weighed at this dose

TABLE C4
Organ-Weight-to-Body-Weight Ratios for Mice in the 13-Week Inhalation Studies of Methyl Bromide^a

Organ	0 ppm		10 ppm		20 ppm		40 ppm		80 ppm		120 ppm	
Male												
Number weighed ^b	10		10		10		10		8		10	
Necropsy body wt	29.0 ± 0.45		30.1 ± 0.32		28.3 ± 0.70		28.7 ± 0.69		27.9 ± 0.85		25.5 ± 0.66**	
Brain	15.7 ± 0.54		15.6 ± 0.35		16.2 ± 0.30		16.0 ± 0.20		16.0 ± 0.51		16.8 ± 0.46	
Heart	6.0 ± 0.18		6.2 ± 0.29		5.6 ± 0.26		5.8 ± 0.21		6.1 ± 0.12		6.0 ± 0.18	
Kidney	9.5 ± 0.29		9.5 ± 0.22		9.2 ± 0.24		9.2 ± 0.25		9.7 ± 0.26		9.0 ± 0.17	
Liver	62.8 ± 1.03		61.0 ± 1.22		58.8 ± 2.46		49.7 ± 1.75**		57.8 ± 2.05**		58.8 ± 2.47**	
Lung	6.2 ± 0.24		6.0 ± 0.24		6.2 ± 0.27		6.3 ± 0.24		6.7 ± 0.19		6.7 ± 0.27	
L. testis	3.7 ± 0.12		3.7 ± 0.13 ^c		3.8 ± 0.21		3.6 ± 0.23		4.1 ± 0.23		4.4 ± 0.31*	
R. testis	3.9 ± 0.13		4.0 ± 0.07				3.9 ± 0.08				4.7 ± 0.13**	
Thymus	1.5 ± 0.16		1.4 ± 0.13		1.4 ± 0.16		1.3 ± 0.17		1.8 ± 0.21		1.9 ± 0.22	
Female												
Number weighed	10		10		10		10		8		10	
Necropsy body wt	23.1 ± 0.36		23.5 ± 0.34		23.5 ± 0.29		23.8 ± 0.41		23.8 ± 0.44		23.3 ± 0.24	
Brain	20.9 ± 0.38		20.0 ± 0.40		20.8 ± 0.34		19.9 ± 0.39		20.2 ± 0.30		19.0 ± 0.33**	
Heart	5.5 ± 0.24		5.5 ± 0.22		5.8 ± 0.21		5.6 ± 0.20		6.1 ± 0.23		5.8 ± 0.15	
Kidney	7.6 ± 0.22		7.6 ± 0.27		7.6 ± 0.22		7.5 ± 0.19		7.9 ± 0.12		8.0 ± 0.30	
Liver	55.2 ± 1.39		58.5 ± 1.26		52.1 ± 0.78		57.1 ± 1.26		55.4 ± 1.14		62.4 ± 1.55**	
Lung	7.8 ± 0.30		8.1 ± 0.20		7.6 ± 0.32		7.6 ± 0.19		7.7 ± 0.20		8.5 ± 0.38	
Thymus	2.0 ± 0.12		1.7 ± 0.16		2.3 ± 0.12		2.5 ± 0.25		1.9 ± 0.30		2.2 ± 0.20	

* Significantly different ($P \leq 0.05$) from the control group by Dunn's or Shirley's test

** $P \leq 0.01$

^a Organ-weight-to body weight ratios are given as mg organ weight/g body weight (mean ± standard error).

^b Except where noted

^c n=9

TABLE C5
Organ Weights for Mice at the 6-Month Interim Evaluation of the 2-Year Inhalation Studies
of Methyl Bromide^a

Organ	0 ppm	10 ppm	33 ppm/kg
Male			
Number weighed	10	10	9
Necropsy body wt	36.6 ± 0.87	37.1 ± 0.74	39.5 ± 0.87*
Brain	0.47 ± 0.01	0.48 ± 0.01	0.47 ± 0.01
Heart	0.18 ± 0.00	0.18 ± 0.00	0.19 ± 0.00
Kidney	0.32 ± 0.01	0.32 ± 0.01	0.30 ± 0.01
Liver	1.65 ± 0.06	1.67 ± 0.03	1.75 ± 0.06
Lung	0.19 ± 0.01	0.20 ± 0.01	0.18 ± 0.00
Spleen	0.07 ± 0.01	0.07 ± 0.00	0.07 ± 0.00
R. testis	0.12 ± 0.00	0.12 ± 0.00	0.12 ± 0.00
Thymus	0.05 ± 0.00	0.04 ± 0.00	0.05 ± 0.00
Female			
Number weighed	10	10	10
Necropsy body wt	31.4 ± 0.80	31.0 ± 1.12	28.0 ± 0.73*
Brain	0.48 ± 0.01	0.48 ± 0.01	0.49 ± 0.01
Heart	0.16 ± 0.01	0.16 ± 0.01	0.15 ± 0.01
Kidney	0.22 ± 0.01	0.21 ± 0.01	0.19 ± 0.01*
Liver	1.55 ± 0.06	1.65 ± 0.09	1.46 ± 0.04
Lung	0.19 ± 0.01	0.19 ± 0.01	0.19 ± 0.01
Spleen	0.09 ± 0.00	0.09 ± 0.00	0.09 ± 0.00
Thymus	0.05 ± 0.00	0.06 ± 0.00	0.05 ± 0.00

* Significantly different ($P \leq 0.05$) from the control group by Dunn's or Shirley's test

^a Organ weights are given in grams (mean ± standard error).

TABLE C6
Organ-Weight-to-Body-Weight Ratios for Mice at the 6-Month Interim Evaluation
of the 2-Year Inhalation Studies of Methyl Bromide^a

Organ	0 ppm	10 ppm	33 ppm/kg
Male			
Number weighed	10	10	9
Necropsy body wt	36.6 ± 0.87	37.1 ± 0.74	39.5 ± 0.87*
Brain	13.0 ± 0.40	12.9 ± 0.32	11.9 ± 0.30
Heart	5.0 ± 0.10	4.8 ± 0.12	4.7 ± 0.16
Kidney	8.7 ± 0.26	8.6 ± 0.29	7.6 ± 0.18**
Liver	45.3 ± 1.57	45.2 ± 1.20	44.3 ± 1.27
Lung	5.1 ± 0.21	5.3 ± 0.18	4.7 ± 0.16
Spleen	2.0 ± 0.15	1.8 ± 0.08	1.7 ± 0.09
R. testis	3.3 ± 0.15	3.3 ± 0.10	3.1 ± 0.07
Thymus	1.4 ± 0.11	1.1 ± 0.05	1.3 ± 0.12
Female			
Number weighed	10	10	10
Necropsy body wt	31.4 ± 0.80	31.0 ± 1.12	28.0 ± 0.73*
Brain	15.2 ± 0.38	15.7 ± 0.49	17.5 ± 0.45**
Heart	5.0 ± 0.21	5.0 ± 0.13	5.3 ± 0.12
Kidney	6.9 ± 0.22	6.8 ± 0.16	6.9 ± 0.23
Liver	49.4 ± 1.43	53.3 ± 1.66	52.2 ± 1.52
Lung	6.0 ± 0.25	6.1 ± 0.26	6.6 ± 0.20
Spleen	3.0 ± 0.10	2.8 ± 0.09	3.2 ± 0.11
Thymus	1.6 ± 0.12	1.9 ± 0.12	1.6 ± 0.13

* Significantly different ($P \leq 0.05$) from the control group by Dunn's or Shirley's test

** $P \leq 0.01$

^a Organ-weight-to-body-weight ratios are given as mg organ weight/g body weight (mean ± standard error).

TABLE C7
Organ Weights for Mice at the 15-Month Interim Evaluation of the 2-Year Inhalation Studies
of Methyl Bromide^a

Organ	0 ppm		10 ppm		33 ppm		100 ppm	
Male								
Number weighed	10		9		10		_ ^b	
Necropsy body wt	48.2 ±	1.54	46.8 ±	1.57	47.3 ±	1.42	-	
Brain	0.47 ±	0.01	0.48 ±	0.01	0.49 ±	0.01	-	
Heart	0.24 ±	0.01	0.24 ±	0.01	0.25 ±	0.01	-	
Kidney	0.43 ±	0.02	0.42 ±	0.01	0.40 ±	0.02	-	
Liver	2.40 ±	0.27	2.59 ±	0.46	2.30 ±	0.26	-	
Lung	0.23 ±	0.01	0.24 ±	0.01	0.29 ±	0.03	-	
R. testis	0.12 ±	0.01	0.12 ±	0.01	0.13 ±	0.01	-	
Thymus	0.08 ±	0.01	0.06 ±	0.01	0.07 ±	0.01	-	
Female								
Number weighed	9		10		10		8	
Necropsy body wt	41.8 ±	1.93	44.4 ±	1.92	39.0 ±	2.03	30.4 ±	1.34**
Brain	0.49 ±	0.01	0.51 ±	0.01	0.50 ±	0.01	0.47 ±	0.01
Heart	0.19 ±	0.01	0.18 ±	0.01	0.18 ±	0.01	0.18 ±	0.00**
Kidney	0.26 ±	0.01	0.28 ±	0.01	0.25 ±	0.01	0.23 ±	0.01
Liver	1.69 ±	0.07	1.86 ±	0.08	1.84 ±	0.09	1.49 ±	0.07
Lung	0.24 ±	0.01	0.24 ±	0.01	0.24 ±	0.01	0.20 ±	0.01*
Thymus	0.06 ±	0.00	0.07 ±	0.01	0.06 ±	0.01	0.04 ±	0.00*

* Significantly different ($P \leq 0.05$) from the control group by Dunn's or Shirley's test

** $P \leq 0.01$

^a Organ weights are given in grams (mean ± standard error).

^b Interim sacrifice not performed due to high early mortality.

TABLE C8
Organ-Weight-to-Body-Weight Ratios for Mice at the 15-Month Interim Evaluation
of the 2-Year Inhalation Studies of Methyl Bromide^a

Organ	0 ppm		10 ppm		33 ppm		100 ppm	
Male								
Number weighed	10		9		10		_ ^b	
Necropsy body wt	48.2 ±	1.54	46.8 ±	1.57	47.3 ±	1.42	-	
Brain	9.8 ±	0.38	10.4 ±	0.44	10.4 ±	0.30	-	
Heart	5.0 ±	0.26	5.1 ±	0.19	5.2 ±	0.16	-	
Kidney	8.9 ±	0.32	9.0 ±	0.25	8.5 ±	0.33	-	
Liver	49.9 ±	5.62	56.5 ±	11.40	48.0 ±	4.38	-	
Lung	4.8 ±	0.19	5.2 ±	0.26	6.2 ±	0.74*	-	
R. testis	2.5 ±	0.12	2.6 ±	0.10	2.8 ±	0.17	-	
Thymus	1.6 ±	0.21	1.3 ±	0.16	1.4 ±	0.22	-	
Female								
Number weighed	9		10		10		8	
Necropsy body wt	41.8 ±	1.93	44.4 ±	1.92	39.0 ±	2.03	30.4 ±	1.34**
Brain	12.0 ±	0.72	11.7 ±	0.58	13.2 ±	0.81	15.6 ±	0.51**
Heart	4.5 ±	0.22	4.2 ±	0.30	4.8 ±	0.30	6.0 ±	0.30**
Kidney	6.3 ±	0.25	6.4 ±	0.30	6.5 ±	0.23	7.7 ±	0.33**
Liver	41.0 ±	1.72	42.2 ±	2.03	47.6 ±	1.91*	48.9 ±	1.41**
Lung	5.8 ±	0.29	5.6 ±	0.31	6.3 ±	0.55	6.7 ±	0.18
Thymus	1.4 ±	0.09	1.6 ±	0.20	1.5 ±	0.17	1.2 ±	0.12

* Significantly different ($P \leq 0.05$) from the control group by Dunn's or Shirley's test

** $P \leq 0.01$

^a Organ-weight-to-body-weight ratios are given as mg organ weight/g body weight (mean ± standard error).

^b Interim sacrifice not performed due to high early mortality.

TABLE C9
Organ Weights for Mice at the Terminal Evaluation of the 2-Year Inhalation Studies of Methyl Bromide^a

Organ	0 ppm		10 ppm		33 ppm		100 ppm	
Male								
Number weighed ^b	40		37		40		16	
Necropsy body wt	45.4 ±	1.05	45.7 ±	0.97	44.6 ±	1.00	30.2 ±	1.03**
Brain	0.47 ±	0.00	0.48 ±	0.00	0.48 ±	0.00	0.46 ±	0.01
Heart	0.26 ±	0.01	0.25 ±	0.01	0.25 ±	0.01	0.21 ±	0.01**
Kidney	0.43 ±	0.01	0.45 ±	0.01	0.43 ±	0.01	0.35 ±	0.01** ^c
Liver	2.87 ±	0.23	2.94 ±	0.18	2.72 ±	0.21	1.85 ±	0.19**
Lung	0.28 ±	0.01 ^d	0.29 ±	0.01 ^e	0.29 ±	0.01	0.22 ±	0.01**
Spleen	0.12 ±	0.01	0.24 ±	0.09	0.17 ±	0.04	0.09 ±	0.02**
R. testis	0.12 ±	0.01	0.09 ±	0.01* ^f	0.12 ±	0.00	0.11 ±	0.00 ^g
Thymus	0.06 ±	0.01 ^e	0.09 ±	0.01 ^e	0.06 ±	0.01 ^h	0.02 ±	0.00** ⁱ
Female								
Number weighed	36		41		45		40	
Necropsy body wt	44.3 ±	1.21	41.0 ±	1.19	40.8 ±	1.08*	30.7 ±	0.73**
Brain	0.49 ±	0.00	0.49 ±	0.00	0.49 ±	0.00	0.47 ±	0.00
Heart	0.21 ±	0.00	0.22 ±	0.01	0.21 ±	0.00	0.20 ±	0.01
Kidney	0.31 ±	0.01	0.31 ±	0.01	0.30 ±	0.02	0.27 ±	0.01**
Liver	1.96 ±	0.06	2.20 ±	0.17	2.10 ±	0.23	1.70 ±	0.07
Lung	0.26 ±	0.01	0.31 ±	0.05	0.27 ±	0.02	0.24 ±	0.01
Spleen	0.26 ±	0.04	0.23 ±	0.03	0.33 ±	0.09	0.16 ±	0.02**
Thymus	0.07 ±	0.01	0.05 ±	0.00 ^j	0.05 ±	0.00** ^k	0.03 ±	0.00** ^c

* Significantly different ($P \leq 0.05$) from the control group by Dunn's or Shirley's test

** $P \leq 0.01$

^a Organ weights are given in grams (mean ± standard error).

^b Except where noted

^c n=15

^d n=39

^e n=36

^f n=35

^g n=14

^h n=38

ⁱ n=12

^j n=37

^k n=44

TABLE C10
Organ-Weight-to-Body-Weight Ratios for Mice at the Terminal Evaluation of the 2-Year Inhalation Studies of Methyl Bromide^a

Organ	0 ppm		10 ppm		33 ppm		100 ppm	
Male								
Number weighed ^b	40		37		40		16	
Necropsy body wt	45.4 ±	1.05	45.7 ±	0.97	44.6 ±	1.00	30.2 ±	1.03**
Brain	10.7 ±	0.26	10.6 ±	0.23	10.9 ±	0.26	15.5 ±	0.45**
Heart	5.9 ±	0.18	5.6 ±	0.19	5.6 ±	0.20	6.9 ±	0.29*
Kidney	9.7 ±	0.27	9.9 ±	0.25	9.8 ±	0.21	11.4 ±	0.26** ^c
Liver	67.9 ±	7.46	66.6 ±	5.40	64.2 ±	6.20	62.6 ±	8.12
Lung	6.3 ±	0.40 ^d	6.5 ±	0.28 ^e	6.8 ±	0.37	7.2 ±	0.33**
Spleen	2.9 ±	0.30	5.2 ±	1.82	4.3 ±	1.33	3.0 ±	0.65
R. testis	2.7 ±	0.16	2.0 ±	0.16 ^f	2.6 ±	0.07	3.5 ±	0.17** ^g
Thymus	1.2 ±	0.11 ^e	1.9 ±	0.21 ^e	1.3 ±	0.09 ^h	0.7 ±	0.11 ⁱ
Female								
Number weighed	36		41		45		40	
Necropsy body wt	44.3 ±	1.21	41.0 ±	1.19	40.8 ±	1.08*	30.7 ±	0.73**
Brain	11.5 ±	0.35	12.4 ±	0.45	12.3 ±	0.32	15.6 ±	0.30**
Heart	4.9 ±	0.14	5.5 ±	0.26	5.3 ±	0.17	6.8 ±	0.27**
Kidney	7.0 ±	0.20	7.9 ±	0.53	7.5 ±	0.37	9.0 ±	0.26**
Liver	45.2 ±	1.57	56.7 ±	5.50	51.9 ±	5.51	55.6 ±	2.15**
Lung	6.0 ±	0.25	8.1 ±	1.31	6.9 ±	0.55	7.8 ±	0.30**
Spleen	6.2 ±	1.14	5.8 ±	0.88	8.1 ±	2.17	5.2 ±	0.64
Thymus	1.4 ±	0.11	1.2 ±	0.10 ^j	1.1 ±	0.07** ^k	1.0 ±	0.09** ^c

* Significantly different ($P \leq 0.05$) from the control group by Dunn's or Shirley's test

** $P \leq 0.01$

^a Organ-weight-to-body-weight ratios are given as mg organ weight/g body weight (mean ± standard error).

^b Except where noted

^c n=15

^d n=39

^e n=36

^f n=35

^g n=14

^h n=38

ⁱ n=12

^j n=37

^k n=44

APPENDIX D NEUROBEHAVIORAL ANALYSES

TABLE D1	Neurobehavioral Data for Rats in the 13-Week Inhalation Studies of Methyl Bromide	146
TABLE D2	Neurobehavioral Data for Mice in the 13-Week Inhalation Studies of Methyl Bromide	150
TABLE D3	Neurobehavioral Data for Mice in the 2-Year Inhalation Studies of Methyl Bromide	153

TABLE D1
Neurobehavioral Data for Rats in the 13-Week Inhalation Studies of Methyl Bromide^a

Parameter/Week	0 ppm	30 ppm	60 ppm	120 ppm
Male				
Body weight (g)				
0	110 ± 4.9	116 ± 5.1	110 ± 4.9	111 ± 4.1
3	182 ± 8.2	185 ± 7.1	171 ± 4.7	174 ± 4.1
6	235 ± 7.8	232 ± 7.4	214 ± 3.9*	211 ± 4.1*
9	281 ± 7.8	275 ± 8.7	256 ± 4.9*	244 ± 6.2**
13	324 ± 6.8	314 ± 10.1	291 ± 6.1**	271 ± 7.0**
Hot plate test (°C)				
0	55.2 ± 0.05	55.3 ± 0.02	55.3 ± 0.03	55.2 ± 0.05
3	55.5 ± 0.09	55.4 ± 0.04	55.5 ± 0.05	55.3 ± 0.08
6	55.3 ± 0.02	55.3 ± 0.02	55.3 ± 0.03	55.3 ± 0.02
9	55.3 ± 0.02	55.3 ± 0.01	55.3 ± 0.02	55.3 ± 0.02
13	55.1 ± 0.07	55.1 ± 0.06	55.1 ± 0.05	55.0 ± 0.09
Hind limb footsplay (cm)				
0	7.6 ± 0.41	8.1 ± 0.48	8.3 ± 0.32	7.9 ± 0.25
3	8.5 ± 0.27	9.2 ± 0.39	8.6 ± 0.39	9.6 ± 0.31
6	9.0 ± 0.54	9.7 ± 0.24	9.0 ± 0.50	9.3 ± 0.48
9	8.6 ± 0.77	9.6 ± 0.39	9.7 ± 0.45	8.8 ± 0.39
13	9.3 ± 0.36	9.6 ± 0.52	9.0 ± 0.21	8.9 ± 0.30
Startle response latency (msec)				
0	417 ± 18.3	406 ± 33.6	441 ± 22.3	434 ± 22.9
3	403 ± 23.0	393 ± 31.0	437 ± 12.9	455 ± 11.9
6	352 ± 30.6	394 ± 18.1	414 ± 19.6	411 ± 14.5
9	363 ± 19.1	415 ± 16.8	408 ± 14.7	408 ± 23.4
13	348 ± 25.7	336 ± 17.0	402 ± 15.1	406 ± 26.0
Startle response amplitude (instrument units)				
0	157 ± 9.6	172 ± 18.6	135 ± 13.3	130 ± 15.3
3	186 ± 8.2	191 ± 20.2	158 ± 7.2*	134 ± 11.6**
6	193 ± 15.5	172 ± 16.5	154 ± 13.9	170 ± 8.2
9	189 ± 10.1	176 ± 14.7	149 ± 10.9	178 ± 17.5
13	201 ± 14.9	209 ± 12.0	177 ± 13.4	175 ± 15.6
Activity latency (sec)				
0	14.1 ± 4.52	8.3 ± 2.36	11.6 ± 2.51	13.5 ± 3.07
3	16.5 ± 4.93	23.6 ± 10.58	13.6 ± 4.02	11.8 ± 4.31
6	23.3 ± 12.31	55.1 ± 27.48	47.1 ± 19.93	54.3 ± 27.48
9	102.1 ± 25.11	54.1 ± 27.76	91.1 ± 28.35	44.4 ± 23.19
13	120.8 ± 29.14	136.6 ± 28.41	80.5 ± 29.38	72.8 ± 26.74
Novel side time (sec)				
0	106.6 ± 12.40	136.9 ± 9.20	113.1 ± 13.10	110.9 ± 11.10
3	153.3 ± 7.30	134.8 ± 15.20	129.9 ± 16.10	136.9 ± 11.10
6	118.3 ± 18.73	107.0 ± 25.51	97.1 ± 17.90	86.6 ± 22.68
9	63.3 ± 23.60	91.4 ± 25.53	76.0 ± 26.87	103.3 ± 22.13
13	32.6 ± 20.56	36.3 ± 24.54	66.8 ± 26.71	51.8 ± 14.69

TABLE D1
Neurobehavioral Data for Rats in the 13-Week Inhalation Studies of Methyl Bromide (continued)

Parameter/Week	0 ppm	30 ppm	60 ppm	120 ppm
Male (continued)				
Novel side crossing (frequency)				
0	7.1 ± 0.77	7.6 ± 0.65	7.0 ± 0.96	9.1 ± 0.93
3	3.3 ± 0.96	3.1 ± 0.61	4.1 ± 0.74	4.5 ± 0.94
6	3.1 ± 0.52	1.6 ± 0.53	4.0 ± 0.73	1.9 ± 0.52
9	1.0 ± 0.38	2.8 ± 1.10	1.3 ± 0.59	2.8 ± 0.84
13	0.5 ± 0.27	0.5 ± 0.38	1.0 ± 0.33	2.4 ± 0.89*
Locomotor activity (instrument units)				
0	201 ± 10.1	201 ± 12.2	198 ± 19.0	205 ± 6.3
3	139 ± 16.5	146 ± 10.0	158 ± 16.4	152 ± 18.9
6	126 ± 15.8	84 ± 20.0	134 ± 16.3	103 ± 11.1
9	66 ± 8.2	66 ± 18.3	64 ± 15.0	94 ± 21.7
13	39 ± 8.9	29 ± 6.0	53 ± 8.5	75 ± 15.3
Forelimb grip strength (g)				
0	121 ± 15.3	188 ± 36.5	173 ± 36.3	164 ± 33.0
3	188 ± 27.4	192 ± 20.9	180 ± 16.3	138 ± 23.7
6	244 ± 34.7	272 ± 16.6	257 ± 19.8	191 ± 22.1
9	261 ± 23.8	242 ± 21.8	271 ± 14.8	250 ± 23.3
13	250 ± 20.7	290 ± 24.1	242 ± 21.5	211 ± 28.3
Hind limb grip strength (g)				
0	33.4 ± 4.83	63.5 ± 12.23	54.6 ± 10.14	45.6 ± 7.46
3	112.1 ± 13.62	116.9 ± 15.50	91.7 ± 11.06	77.9 ± 12.95
6	137.9 ± 13.57	111.0 ± 12.64	132.3 ± 13.49	93.5 ± 12.20*
9	153.8 ± 11.90	142.1 ± 11.40	159.2 ± 12.80	127.7 ± 12.90
13	177.5 ± 14.30	146.7 ± 22.00	155.0 ± 25.60	155.2 ± 14.80
Hot plate latency (sec)				
0	5.2 ± 0.31	5.1 ± 0.29	4.9 ± 0.31	5.8 ± 0.50
3	4.1 ± 0.17	4.0 ± 0.18	3.9 ± 0.30	3.9 ± 0.23
6	4.3 ± 0.31	4.2 ± 0.31	4.5 ± 0.22	4.0 ± 0.22
9	3.6 ± 0.23	3.6 ± 0.21	4.0 ± 0.39	3.3 ± 0.15
13	5.0 ± 0.30	5.0 ± 0.22	4.8 ± 0.35	4.5 ± 0.22
Female				
Body weight (g)				
0	91 ± 2.8	92 ± 3.7	93 ± 3.9	92 ± 3.2
3	132 ± 2.3	132 ± 5.0	133 ± 5.7	126 ± 2.9
6	155 ± 2.5	155 ± 4.7	159 ± 5.8	144 ± 1.7
9	173 ± 3.4	171 ± 5.1	170 ± 6.4	156 ± 2.2*
13	191 ± 4.6	190 ± 6.0	186 ± 6.7	164 ± 2.5**
Hot plate test (°C)				
0	55.1 ± 0.11	55.2 ± 0.08	55.0 ± 0.16	55.1 ± 0.15
3	55.4 ± 0.10	55.3 ± 0.08	55.4 ± 0.08	55.3 ± 0.21
6	55.3 ± 0.11	55.1 ± 0.11	55.4 ± 0.08	55.5 ± 0.09
9	55.2 ± 0.06	55.3 ± 0.07	55.3 ± 0.06	55.4 ± 0.08*
13	55.0 ± 0.10	55.2 ± 0.24	55.2 ± 0.09	55.1 ± 0.13

TABLE D1
Neurobehavioral Data for Rats in the 13-Week Inhalation Studies of Methyl Bromide (continued)

Parameter/Week	0 ppm	30 ppm	60 ppm	120 ppm
Female (continued)				
Hind limb footsplay (cm)				
0	7.2 ± 0.16	6.9 ± 0.28	7.0 ± 0.24	7.4 ± 0.31
3	7.7 ± 0.30	7.4 ± 0.25	7.8 ± 0.44	8.4 ± 0.18
6	7.5 ± 0.12	7.5 ± 0.45	7.8 ± 0.31	6.9 ± 0.33
9	7.4 ± 0.24	7.1 ± 0.30	7.5 ± 0.27	7.1 ± 0.25
13	7.6 ± 0.37	7.3 ± 0.34	7.6 ± 0.18	6.1 ± 0.28* ^b
Startle response latency (msec)				
0	416 ± 13.7	427 ± 6.9	409 ± 18.9	418 ± 22.9
3	408 ± 20.9	436 ± 21.0	430 ± 9.6	458 ± 9.7*
6	415 ± 14.4	393 ± 27.5	428 ± 24.4	444 ± 13.8
9	431 ± 17.5	418 ± 17.2	438 ± 18.4	428 ± 20.6
13	376 ± 25.5	383 ± 29.2	437 ± 19.9	439 ± 9.7*
Startle response amplitude (instrument units)				
0	170 ± 10.0	160 ± 5.2	163 ± 11.0	171 ± 22.6
3	173 ± 14.9	180 ± 14.8	159 ± 3.7	149 ± 11.6
6	160 ± 9.4	181 ± 15.5	153 ± 15.4	148 ± 11.3
9	152 ± 11.6	166 ± 5.7	151 ± 8.9	162 ± 17.0
13	182 ± 18.5	196 ± 20.5	153 ± 12.2	142 ± 8.8*
Activity latency (sec)				
0	7.6 ± 2.41	11.9 ± 3.69	10.9 ± 4.53	7.3 ± 2.60
3	14.3 ± 4.91	5.0 ± 1.16	6.3 ± 1.36	11.8 ± 2.96
6	29.3 ± 21.73	6.9 ± 1.93	25.9 ± 14.21	59.4 ± 26.78
9	40.5 ± 20.90	25.9 ± 10.50	14.1 ± 7.65	65.6 ± 25.71
13	43.5 ± 24.96	11.8 ± 4.76	29.5 ± 21.58	33.1 ± 21.36
Novel side time (sec)				
0	119.0 ± 9.30	115.8 ± 11.80	113.0 ± 7.90	125.5 ± 9.60
3	145.0 ± 5.50	146.3 ± 12.10	116.6 ± 11.80	138.1 ± 9.50
6	107.5 ± 19.17	140.3 ± 12.33	105.6 ± 15.32	65.1 ± 18.63
9	108.8 ± 20.64	108.4 ± 17.09	129.9 ± 16.74	80.0 ± 22.93
13	92.0 ± 20.18	141.6 ± 17.06	111.6 ± 23.86	108.3 ± 19.72
Novel side crossing (frequency)				
0	10.3 ± 1.11	8.6 ± 0.94	9.4 ± 1.45	9.1 ± 0.90
3	4.7 ± 0.56	5.0 ± 0.57	5.0 ± 0.50	5.2 ± 0.59
6	4.5 ± 0.80	3.9 ± 1.09	3.6 ± 0.75	3.1 ± 0.85
9	2.4 ± 0.68	3.3 ± 1.00	2.5 ± 0.53	3.0 ± 1.07
13	4.2 ± 0.96	2.1 ± 0.40	2.0 ± 0.53	4.1 ± 1.04
Locomotor activity (instrument units)				
0	216 ± 11.2	208 ± 12.0	192 ± 12.1	210 ± 5.0
3	159 ± 14.8	141 ± 11.0	155 ± 13.4	164 ± 8.1
6	127 ± 14.3	133 ± 11.8	133 ± 15.5	104 ± 17.7
9	107 ± 15.0	87 ± 11.3	93 ± 14.8	107 ± 22.2
13	109 ± 14.3	73 ± 17.6	77 ± 19.5	101 ± 16.1

TABLE D1
Neurobehavioral Data for Rats in the 13-Week Inhalation Studies of Methyl Bromide (continued)

Parameter/Week	0 ppm	30 ppm	60 ppm	120 ppm
Female (continued)				
Forelimb grip strength (g)				
0	132 ± 26.1	176 ± 31.6	245 ± 40.7	157 ± 33.4
3	155 ± 27.8	166 ± 23.2	160 ± 18.9	194 ± 49.3
6	160 ± 25.0	178 ± 11.5	171 ± 18.8	135 ± 23.7
9	274 ± 22.5	267 ± 25.2	250 ± 17.6	219 ± 24.6
13	266 ± 18.3	222 ± 25.8	261 ± 15.1	197 ± 23.0*
Hind limb grip strength (g)				
0	47.9 ± 6.03	53.3 ± 4.50	53.7 ± 4.83	60.2 ± 9.74
3	95.8 ± 15.06	107.3 ± 8.23	109.4 ± 13.63	63.6 ± 9.09
6	107.5 ± 9.03	92.1 ± 8.07	84.2 ± 6.95	88.7 ± 14.06
9	147.5 ± 11.90	139.6 ± 15.60	130.0 ± 14.20	128.7 ± 9.70
13	164.0 ± 7.00	148.8 ± 15.90	151.3 ± 6.60	136.3 ± 14.20
Hot plate latency (sec)				
0	4.7 ± 0.25	5.4 ± 0.43	5.3 ± 0.45	5.5 ± 0.19
3	4.6 ± 0.27	4.0 ± 0.26	4.2 ± 0.27	3.6 ± 0.28*
6	3.8 ± 0.18	4.4 ± 0.26	4.0 ± 0.31	3.6 ± 0.37
9	3.3 ± 0.28	3.6 ± 0.31	4.1 ± 0.22	3.7 ± 0.35
13	4.7 ± 0.21	5.0 ± 0.24	5.5 ± 0.51	4.8 ± 0.36

* Significantly different ($P \leq 0.05$) from the control group by Dunn's or Shirley's test

** $P \leq 0.01$

^a Mean ± standard error given for groups of 8 animals unless otherwise specified.

^b n=7

TABLE D2
Neurobehavioral Data for Mice in the 13-Week Inhalation Studies of Methyl Bromide^a

Parameter/Week	0 ppm	20 ppm	40 ppm	80 ppm
Male				
Body weight (g)				
0	21.8 ± 0.48	21.9 ± 0.45	20.9 ± 0.71	22.5 ± 0.36
6	28.4 ± 0.41	27.6 ± 0.45	20.9 ± 0.65	27.5 ± 0.42
12	30.6 ± 0.46	29.1 ± 0.45	28.1 ± 0.77*	29.7 ± 0.45
Hot plate test (°C)				
0	56.3 ± 0.28	56.5 ± 0.38	56.0 ± 0.22	56.2 ± 0.42
6	55.0 ± 0.29	55.1 ± 0.11	55.4 ± 0.18	55.2 ± 0.24
12	54.0 ± 0.57 ^b	54.1 ± 0.47 ^b	54.2 ± 0.62 ^c	54.8 ± 0.47 ^d
Hind limb footsplay (cm)				
0	3.2 ± 0.13	3.2 ± 0.09	3.2 ± 0.17	3.0 ± 0.20
6	3.0 ± 0.21	3.0 ± 0.16	3.3 ± 0.18	3.4 ± 0.13
12	3.3 ± 0.13	3.0 ± 0.11	2.9 ± 0.14	3.2 ± 0.13
Startle response latency (msec)				
0	79.5 ± 4.73	77.0 ± 3.56	87.4 ± 4.94	79.0 ± 5.40
6	87.2 ± 3.37	90.8 ± 3.20	91.1 ± 2.88	91.5 ± 2.97
12	87.4 ± 2.56	78.5 ± 8.10	88.1 ± 3.00	89.0 ± 3.32
Startle response amplitude (instrument units)				
0	210 ± 21.1	230 ± 14.1	164 ± 15.7	234 ± 29.8
6	163 ± 15.2	177 ± 11.1	160 ± 10.0	166 ± 7.4
12	188 ± 6.6	208 ± 26.7	167 ± 9.8	163 ± 11.5
Activity latency (sec)				
0	16.8 ± 2.88	14.0 ± 3.14	13.1 ± 3.10	10.5 ± 2.90
6	9.1 ± 1.91	17.0 ± 5.37	13.4 ± 4.47	23.3 ± 3.07**
12	12.1 ± 0.91	34.5 ± 20.91	19.5 ± 3.38	10.6 ± 2.15
Novel side time (sec)				
0	98.0 ± 9.77	104.8 ± 4.24	109.6 ± 5.95	111.0 ± 7.93
6	121.4 ± 4.80	112.4 ± 9.20	119.3 ± 11.00	108.5 ± 7.80
12	141.0 ± 5.60	137.0 ± 9.70	113.9 ± 13.90	135.5 ± 12.20
Novel side crossing (frequency)				
0	9.4 ± 1.03	10.5 ± 1.56	8.9 ± 1.16	7.0 ± 1.02
6	7.4 ± 0.46	5.2 ± 0.80	5.2 ± 0.45*	5.9 ± 0.55
12	5.2 ± 0.88	3.8 ± 0.86	4.2 ± 0.65	5.1 ± 1.06
Locomotor activity (instrument units)				
0	177 ± 6.9	179 ± 8.5	167 ± 9.3	180 ± 9.9
6	155 ± 7.6 ^c	161 ± 11.6	160 ± 7.8	155 ± 6.8
12	124 ± 10.3	122 ± 17.1	125 ± 6.7	125 ± 8.9
Forelimb grip strength (g)				
0	42.1 ± 6.31	59.8 ± 13.73 ^c	64.4 ± 9.55	57.8 ± 5.76
6	50.7 ± 8.83	41.6 ± 11.50 ^c	75.4 ± 6.17	63.4 ± 10.60 ^c
12	71.2 ± 12.60 ^c	41.5 ± 6.72 ^e	50.2 ± 4.89	81.1 ± 12.02

TABLE D2
Neurobehavioral Data for Mice in the 13-Week Inhalation Studies of Methyl Bromide (continued)

Parameter/Week	0 ppm	20 ppm	40 ppm	80 ppm
Male (continued)				
Hind limb grip strength (g)				
0	30.4 ± 5.48	30.2 ± 6.31	26.2 ± 4.44 ^e	46.4 ± 5.50 ^c
6	46.3 ± 9.17	34.2 ± 7.97 ^e	43.2 ± 9.41	36.1 ± 4.55 ^e
12	46.2 ± 7.96	37.5 ± 5.23	35.4 ± 3.83	42.7 ± 6.92
Hot plate latency (sec)				
0	8.0 ± 0.62	6.9 ± 0.65	6.7 ± 0.57	7.2 ± 0.78
6	6.6 ± 0.84 ^b	7.2 ± 1.07	8.2 ± 1.10	11.9 ± 2.04*
12	4.4 ± 0.42 ^b	5.6 ± 1.89 ^b	5.9 ± 1.06 ^c	6.0 ± 1.47 ^d
Female				
Body weight (g)				
0	17.2 ± 0.31	17.2 ± 0.38	17.3 ± 0.31	17.8 ± 0.27
6	22.8 ± 0.48	22.4 ± 0.50	22.0 ± 0.42	22.7 ± 0.35
12	24.5 ± 0.51	23.7 ± 0.39	23.2 ± 0.21	24.2 ± 0.33
Hot plate test (°C)				
0	54.1 ± 0.40	53.5 ± 0.73	53.9 ± 0.77	53.5 ± 0.67
6	54.9 ± 0.09	55.0 ± 0.10	54.9 ± 0.20	55.0 ± 0.09
12	54.8 ± 0.12	54.8 ± 0.12	54.9 ± 0.21	54.7 ± 0.10
Hind limb footsplay (cm)				
0	2.9 ± 0.11	2.9 ± 0.11	2.7 ± 0.12	2.9 ± 0.12
6	2.9 ± 0.13	2.9 ± 0.12	3.1 ± 0.10	3.0 ± 0.16
12	3.2 ± 0.16	3.1 ± 0.23	3.0 ± 0.14	3.2 ± 0.19
Startle response latency (msec)				
0	86.8 ± 2.54	88.2 ± 3.74	82.0 ± 3.96	81.1 ± 3.94
6	94.7 ± 1.70	95.5 ± 2.71	88.3 ± 4.03	91.2 ± 2.69
12	89.0 ± 3.10	95.6 ± 2.27	86.5 ± 2.46	82.6 ± 2.19
Startle response amplitude (instrument units)				
0	161 ± 8.0	154 ± 11.9	184 ± 15.0	179 ± 13.1
6	132 ± 8.5	144 ± 9.8	168 ± 11.1	144 ± 7.3
12	161 ± 8.1	160 ± 8.1	186 ± 6.3*	178 ± 6.0
Activity latency (sec)				
0	11.3 ± 3.24	16.3 ± 1.56	24.0 ± 3.70*	18.4 ± 4.11
6	17.0 ± 4.77	9.0 ± 1.05	21.0 ± 4.80	15.3 ± 2.99
12	30.3 ± 13.64	12.0 ± 2.00	10.4 ± 2.52	7.1 ± 1.88*
Novel side time (sec)				
0	105.6 ± 5.32	102.8 ± 3.10	96.5 ± 2.19	108.1 ± 3.76
6	118.9 ± 3.70	128.1 ± 5.30	106.4 ± 2.30*	118.6 ± 3.90
12	110.3 ± 8.00	123.6 ± 10.70	136.8 ± 9.30	132.1 ± 6.80

TABLE D2
Neurobehavioral Data for Mice in the 13-Week Inhalation Studies of Methyl Bromide (continued)

Parameter/Week	0 ppm	20 ppm	40 ppm	80 ppm
Female (continued)				
Novel side crossing (frequency)				
0	9.1 ± 0.55	9.5 ± 0.68	10.0 ± 1.13	8.8 ± 0.75
6	7.4 ± 1.35	6.3 ± 1.00	8.4 ± 1.12	8.0 ± 0.65
12	5.9 ± 0.93	7.0 ± 0.98	5.4 ± 1.08	7.8 ± 0.90
Locomotor activity (instrument units)				
0	188 ± 4.3	185 ± 7.0	197 ± 5.5	183 ± 4.4
6	178 ± 5.2	153 ± 6.6	173 ± 11.9	162 ± 8.1
12	160 ± 13.7	162 ± 7.2	157 ± 11.1	152 ± 9.7
Forelimb grip strength (g)				
0	53.9 ± 9.01	36.1 ± 7.99	43.7 ± 6.26	49.7 ± 7.04
6	69.2 ± 6.63	83.5 ± 7.68	84.7 ± 8.36	55.4 ± 6.70
12	65.6 ± 7.59	55.5 ± 5.84 ^e	54.6 ± 9.60	52.2 ± 9.46
Hind limb grip strength (g)				
0	20.1 ± 4.17 ^e	30.3 ± 5.17	28.8 ± 5.71	34.5 ± 10.45
6	34.0 ± 5.07	55.0 ± 4.83	44.8 ± 7.17	41.0 ± 8.41
12	49.5 ± 7.06 ^e	47.1 ± 4.50	43.1 ± 9.80	50.7 ± 5.70
Hot plate latency (sec)				
0	6.8 ± 0.47	7.9 ± 0.55	7.9 ± 1.31	8.9 ± 1.58
6	8.1 ± 0.81	8.0 ± 0.92	9.4 ± 1.18	7.4 ± 0.97
12	9.6 ± 1.04	9.1 ± 1.12	10.2 ± 1.31	6.8 ± 0.86

* Significantly different ($P \leq 0.05$) from the control group by Dunn's or Shirley's test

** $P \leq 0.01$

a Mean ± standard error given for groups of 8 animals unless otherwise specified.

b n=5

c n=6

d n=4

e n=7

TABLE D3
Neurobehavioral Data for Mice in the 2-Year Inhalation Studies of Methyl Bromide^a

Parameter/Month	0 ppm	10 ppm	33 ppm	100 ppm
Male				
Number examined ^b	6	8	12	13
Body weight (g)				
0	21.1 ± 0.39 ^c	21.3 ± 0.36 ^c	21.3 ± 0.40 ^c	21.2 ± 0.48 ^c
3	30.0 ± 0.49 ^c	31.8 ± 0.57 ^c	31.4 ± 0.52 ^c	28.6 ± 0.66 ^d
6	35.3 ± 0.90 ^d	36.6 ± 0.63 ^c	36.1 ± 0.69 ^c	
9	40.8 ± 1.28 ^e	42.2 ± 1.18 ^f	39.9 ± 0.77	
12	44.3 ± 1.29 ^e	44.2 ± 1.03 ^f	43.5 ± 0.74	
15	46.1 ± 1.50 ^e	46.5 ± 1.27 ^f	44.9 ± 0.97	
18	45.4 ± 3.02	48.0 ± 1.47	44.8 ± 1.45 ^g	
21	46.8 ± 2.83	47.6 ± 1.94	45.1 ± 2.22 ^h	
24	45.5 ± 2.20	47.6 ± 1.89	44.0 ± 2.65 ^h	
Startle response latency (msec)				
0	337 ± 23.1 ^c	373 ± 15.0 ^c	356 ± 23.6 ^c	353 ± 16.4 ^c
3	395 ± 15.5 ^c	358 ± 22.6 ^c	332 ± 22.5 ^c	267 ± 16.8 ^{**d}
6	380 ± 14.8 ^d	357 ± 17.3 ^c	391 ± 16.6 ^c	
9	416 ± 17.1 ^e	333 ± 28.9 ^f	405 ± 20.2	
12	398 ± 23.7 ^e	369 ± 20.6 ^f	329 ± 31.7	
15	438 ± 16.1 ^e	364 ± 36.8 ^f	344 ± 30.2 [*]	
18	389 ± 27.8	422 ± 21.1	393 ± 40.5 ^g	
21	430 ± 23.9	352 ± 52.7	348 ± 45.9 ^h	
24	412 ± 20.7	377 ± 41.6	394 ± 65.0 ^h	
Startle response amplitude (instrument units)				
0	216 ± 14.0 ^c	197 ± 8.6 ^c	216 ± 13.7 ^c	214 ± 13.1 ^{*c}
3	190 ± 10.3 ^c	227 ± 18.4 ^c	224 ± 12.1 ^{*c}	307 ± 25.1 ^{**d}
6	199 ± 8.8 ^d	209 ± 9.8 ^c	194 ± 7.7 ^c	
9	162 ± 13.7 ^e	225 ± 33.6 ^f	172 ± 15.4	
12	182 ± 15.3 ^e	200 ± 15.1 ^f	240 ± 28.1 [*]	
15	153 ± 14.6 ^e	208 ± 31.8 ^f	228 ± 21.2 [*]	
18	196 ± 23.9	153 ± 13.2	175 ± 29.2 ^g	
21	158 ± 20.3	217 ± 33.3	201 ± 33.1 ^h	
24	171 ± 17.8	185 ± 23.0	163 ± 37.1 ^h	
Activity latency (sec)				
0	16.3 ± 2.35 ^c	17.0 ± 3.33 ^c	12.6 ± 2.43 ^c	13.9 ± 1.29 ^c
3	18.3 ± 2.22 ^c	17.6 ± 2.81 ^c	26.8 ± 3.98 ^c	86.0 ± 21.67 ^{**d}
6	16.6 ± 3.81 ^d	24.1 ± 6.82 ^c	26.9 ± 7.91 ^c	
9	26.1 ± 10.07 ^e	25.6 ± 8.44 ^f	14.3 ± 2.31	
12	9.8 ± 2.88 ^e	23.5 ± 5.10 ^{*f}	26.4 ± 5.93	
15	15.4 ± 2.30 ^f	22.8 ± 5.85 ^f	15.9 ± 2.42	
18	14.8 ± 3.32	23.1 ± 7.74	23.1 ± 7.54 ^g	
21	15.5 ± 3.58	20.9 ± 5.51	13.5 ± 1.89 ^h	
24	18.3 ± 4.78	30.0 ± 6.49	20.8 ± 5.01 ^h	

TABLE D3
Neurobehavioral Data for Mice in the 2-Year Inhalation Studies of Methyl Bromide (continued)

Parameter/Month	0 ppm	10 ppm	33 ppm	100 ppm
Male (continued)				
Number examined	6	8	12	13
Novel side time (sec)				
0	97.8 ± 2.67 ^c	102.1 ± 4.41 ^c	102.1 ± 3.63 ^c	100.4 ± 3.55 ^c
3	107.3 ± 4.19 ^c	116.1 ± 4.90 ^c	111.7 ± 4.99 ^c	59.9 ± 14.28 ^{*d}
6	108.0 ± 5.60 ^d	111.8 ± 6.60 ^c	106.9 ± 6.20 ^c	
9	116.1 ± 12.00 ^e	100.8 ± 6.50 ^f	111.9 ± 9.10	
12	131.8 ± 8.40 ^e	107.3 ± 5.40 ^{*f}	108.5 ± 8.00	
15	117.2 ± 9.10 ^e	111.5 ± 10.80 ^f	106.5 ± 8.10	
18	125.2 ± 11.00	101.8 ± 9.50	120.6 ± 13.20 ^g	
21	125.2 ± 7.90	120.9 ± 9.60	133.2 ± 11.70 ^h	
24	116.5 ± 7.70	120.9 ± 10.00	123.8 ± 12.90 ^h	
Novel side crossing (frequency)				
0	9.2 ± 0.65 ^c	7.6 ± 0.61 ^c	9.1 ± 0.81 ^c	9.1 ± 0.69 ^c
3	7.8 ± 0.78 ^c	7.2 ± 0.67 ^c	6.9 ± 0.69 ^c	2.6 ± 0.66 ^{**d}
6	6.6 ± 0.47 ^d	6.1 ± 0.52 ^c	5.1 ± 0.53 ^c	
9	4.1 ± 0.62 ^e	5.7 ± 0.64 ^f	5.2 ± 0.69	
12	5.5 ± 0.91 ^e	4.2 ± 0.37 ^f	4.5 ± 0.68	
15	5.4 ± 0.72 ^e	4.2 ± 0.43 ^f	4.9 ± 0.60	
18	5.8 ± 0.98	4.9 ± 0.79	4.1 ± 0.63 ^g	
21	4.7 ± 0.84	4.2 ± 0.67	4.7 ± 1.12 ^h	
24	5.5 ± 0.85	2.9 ± 0.61	3.7 ± 0.71 ^h	
Locomotor activity (instrument units)				
0	184 ± 5.9 ^c	188 ± 3.9 ^c	179 ± 4.9 ^j	187 ± 5.4 ^c
3	189 ± 3.7 ^j	178 ± 5.2 ^c	174 ± 11.2 ^c	112 ± 16.8 ^{**d}
6	184 ± 4.3 ^d	155 ± 10.8 ^{**c}	158 ± 4.2 ^{**c}	
9	147 ± 7.1 ^e	155 ± 6.3 ^k	144 ± 7.2	
12	164 ± 11.2 ^e	154 ± 6.5 ^f	151 ± 9.2	
15	155 ± 7.5 ^e	128 ± 11.3 ^f	133 ± 10.7	
18	141 ± 7.5	147 ± 7.8	129 ± 18.6 ^g	
21	129 ± 11.1	139 ± 9.7	146 ± 8.9 ^h	
24	134 ± 8.0	135 ± 5.4	124 ± 10.0 ^h	
Forelimb grip strength (g)				
0	66.0 ± 6.56 ^c	61.5 ± 5.12 ^c	62.3 ± 5.50 ^c	64.7 ± 5.59 ^c
3	97.3 ± 8.16 ^c	92.1 ± 5.43 ^c	98.4 ± 5.84 ^c	113.1 ± 4.52 ^d
6	102.0 ± 5.60 ^d	102.4 ± 3.90 ^c	103.3 ± 5.40 ^c	
9	99.7 ± 6.49 ^e	97.8 ± 4.17 ^f	94.7 ± 5.18	
12	92.3 ± 5.05 ^e	94.2 ± 5.83 ^f	84.1 ± 5.95	
15	83.8 ± 5.80 ^e	97.5 ± 4.99 ^f	91.7 ± 6.71	
18	96.7 ± 9.69	91.9 ± 4.39	93.3 ± 9.72 ^g	
21	93.0 ± 7.88	104.5 ± 8.81 ^g	96.7 ± 10.92 ^h	
24	100.3 ± 5.71	85.6 ± 7.18	95.0 ± 5.11 ^h	

TABLE D3
Neurobehavioral Data for Mice in the 2-Year Inhalation Studies of Methyl Bromide (continued)

Parameter/Month	0 ppm	10 ppm	33 ppm	100 ppm
Male (continued)				
Number examined	6	8	12	13
Hind limb grip strength (g)				
0	29.4 ± 4.79 ^c	35.7 ± 4.83 ^j	30.4 ± 4.54 ^c	34.7 ± 4.94 ^j
3	57.3 ± 4.41 ^c	52.9 ± 5.01 ^c	54.6 ± 4.36 ^c	74.5 ± 5.72 ^{*d}
6	68.7 ± 5.26 ^d	64.9 ± 4.85 ^c	63.7 ± 5.29 ^c	
9	77.5 ± 7.28 ^e	79.7 ± 3.17 ^f	73.6 ± 4.89	
12	99.7 ± 2.22 ^e	91.0 ± 3.78 ^f	79.0 ± 5.34 ^{**}	
15	67.0 ± 8.27 ^c	71.0 ± 5.57 ^f	63.3 ± 6.34	
18	77.5 ± 5.35	75.4 ± 5.23	76.4 ± 5.79 ^g	
21	86.7 ± 9.29	81.0 ± 7.76	75.0 ± 8.57 ^h	
24	75.9 ± 5.93	77.1 ± 8.91	89.4 ± 10.65 ^h	
Hot plate latency (sec)				
0	8.0 ± 0.50 ^c	8.4 ± 0.96 ^c	7.4 ± 0.61 ^j	7.9 ± 0.63 ^c
3	9.5 ± 0.52 ^c	10.3 ± 1.07 ^c	9.6 ± 1.12 ^c	15.5 ± 2.21 ^{*f}
6	9.5 ± 1.03 ^d	9.7 ± 0.96 ^c	9.9 ± 0.95 ^c	
9	7.3 ± 1.13 ^e	7.5 ± 0.56 ^f	6.7 ± 0.70	
12	6.6 ± 0.83 ^e	6.8 ± 1.01 ^f	6.8 ± 0.77	
15	6.1 ± 0.94 ^e	7.7 ± 0.79 ^f	6.6 ± 0.69	
18	8.9 ± 1.76	8.3 ± 0.88	7.7 ± 0.99 ^g	
21	7.3 ± 1.14	7.6 ± 1.15	7.2 ± 1.02 ^h	
24	10.6 ± 2.30	6.8 ± 0.72	6.8 ± 1.13 ^h	
Hind limb footsplay (cm)				
0	5.6 ± 0.11 ^c	5.2 ± 0.11 ^{*j}	5.0 ± 0.16 ^{*c}	5.2 ± 0.14 ^{*c}
3	5.4 ± 0.11 ^c	5.4 ± 0.14 ^j	5.4 ± 0.12 ^j	
6	5.9 ± 0.12 ^d	5.6 ± 0.18 ^c	5.8 ± 0.17 ^c	
9	5.6 ± 0.16 ^e	5.5 ± 0.18 ^f	5.7 ± 0.14 ^f	
12	5.4 ± 0.16 ^e	5.8 ± 0.20 ^f	5.9 ± 0.16 ^f	
15	5.9 ± 0.19 ^e	5.8 ± 0.17 ^f	6.0 ± 0.18 ^k	
18	6.0 ± 0.37	6.3 ± 0.12	6.2 ± 0.23 ^g	
21	6.2 ± 0.22	5.6 ± 0.22 ^g	6.3 ± 0.30 ^h	
24	5.6 ± 0.21	5.8 ± 0.22	6.2 ± 0.17 ^h	

TABLE D3
Neurobehavioral Data for Mice in the 2-Year Inhalation Studies of Methyl Bromide (continued)

Parameter/Month	0 ppm	10 ppm	33 ppm	100 ppm
Female				
Number examined	6	7	16	10
Body weight (g)				
0	16.5 ± 0.43 ^j	17.3 ± 0.32 ^c	16.6 ± 0.31	17.0 ± 0.41 ^c
3	26.7 ± 0.31 ^l	27.0 ± 0.38 ^c	25.6 ± 0.47	25.3 ± 0.49 ^j
6	28.4 ± 0.62 ^f	29.1 ± 0.68 ^c	27.1 ± 0.60	27.4 ± 0.68
9	34.2 ± 1.17 ^l	35.7 ± 1.32 ^f	31.5 ± 0.99 ^f	30.6 ± 0.66 [*]
12	37.0 ± 0.82 ⁱ	39.5 ± 1.66 ^f	32.4 ± 1.46 ^f	31.8 ± 1.13 [*]
15	38.8 ± 1.29 ^l	41.3 ± 1.90 ^k	32.1 ± 1.25 ^{**f}	31.3 ± 1.00 ^{**}
18	38.6 ± 0.76	43.8 ± 1.98	34.1 ± 1.30 ^l	32.8 ± 2.00 ^h
21	38.7 ± 1.11	43.9 ± 2.44	35.7 ± 1.69 ^h	33.5 ± 2.45 ^h
24	39.6 ± 0.87	46.3 ± 2.78	37.1 ± 1.43 ^h	33.2 ± 2.72 ^h
Startle response latency (msec)				
0	354 ± 15.6 ^j	408 ± 13.9 ^{*c}	393 ± 12.6	342 ± 21.1 ^c
3	373 ± 16.3 ^f	373 ± 15.2 ^c	365 ± 17.6	230 ± 19.6 ^{**j}
6	355 ± 17.8 ⁱ	383 ± 13.4 ^c	412 ± 14.3 ^{**}	361 ± 32.1
9	342 ± 32.8 ^l	340 ± 28.3 ^f	372 ± 25.3 ^l	301 ± 22.1
12	357 ± 32.4 ^l	353 ± 29.4 ^f	388 ± 28.2 ^f	300 ± 36.2
15	371 ± 39.1 ^l	349 ± 29.4 ^k	421 ± 17.8 ⁱ	373 ± 28.4
18	438 ± 11.9	419 ± 31.5	434 ± 34.6 ^l	416 ± 50.2 ^h
21	406 ± 55.3	342 ± 31.9	425 ± 32.2 ^h	311 ± 51.9 ^h
24	439 ± 23.0	347 ± 44.5	365 ± 38.6 ^h	259 ± 64.9 ^{*h}
Startle response amplitude (instrument units)				
0	205 ± 14.7 ^j	179 ± 6.7 ^c	182 ± 7.7	236 ± 20.7 ^c
3	201 ± 7.1 ^j	199 ± 10.9 ^c	210 ± 12.0	333 ± 20.0 ^{**j}
6	214 ± 9.9 ^f	189 ± 8.2 ^c	186 ± 12.0	220 ± 30.4
9	202 ± 19.8 ⁱ	222 ± 13.4 ^f	191 ± 15.4 ^f	242 ± 15.1
12	210 ± 21.4 ^l	209 ± 12.0 ^f	189 ± 21.5 ^f	276 ± 24.4
15	183 ± 17.9 ^l	204 ± 12.6 ^k	159 ± 17.4 ^f	181 ± 24.9
18	142 ± 16.0	155 ± 22.8	122 ± 21.3 ^l	138 ± 31.6 ^h
21	165 ± 34.2	197 ± 13.2	144 ± 33.7 ^h	284 ± 89.9 ^h
24	149 ± 22.3	190 ± 26.6	207 ± 38.3 ^h	283 ± 78.6 ^h
Activity latency (sec)				
0	20.3 ± 4.40 ^j	21.7 ± 4.32 ^c	18.7 ± 3.85	18.7 ± 2.78 ^c
3	29.7 ± 7.07 ^l	16.8 ± 2.93 ^c	23.7 ± 5.17 ^j	22.5 ± 3.30 ^j
6	16.4 ± 4.07 ^f	21.4 ± 4.86 ^c	18.2 ± 4.20	14.2 ± 3.33
9	15.1 ± 3.02 ^l	23.0 ± 10.55 ^k	11.5 ± 1.53 ^f	15.7 ± 2.03
12	9.2 ± 1.64 ^l	12.4 ± 3.04 ^f	18.8 ± 6.06 ^f	28.8 ± 17.00
15	11.3 ± 1.49 ^l	10.4 ± 2.57 ^e	17.0 ± 5.77 ^f	25.4 ± 5.24 [*]
18	11.2 ± 2.68	14.0 ± 4.28	8.8 ± 2.96 ^l	18.3 ± 5.21 ^h
21	14.7 ± 2.51	13.4 ± 3.18	11.7 ± 2.82 ^h	29.0 ± 9.39 ^h
24	11.8 ± 1.66	25.1 ± 6.78	8.2 ± 1.14 ^h	18.3 ± 7.52 ^h

TABLE D3
Neurobehavioral Data for Mice in the 2-Year Inhalation Studies of Methyl Bromide (continued)

Parameter/Month	0 ppm	10 ppm	33 ppm	100 ppm
Female (continued)				
Number examined	6	7	16	10
Novel side time (sec)				
0	95.9 ± 3.95 ^j	102.8 ± 4.59 ^c	97.3 ± 3.23	99.7 ± 3.21 ^c
3	100.5 ± 5.90 ^l	115.3 ± 3.90 ^c	112.4 ± 5.20	119.3 ± 3.40 ^{*j}
6	109.5 ± 5.30 ^f	111.1 ± 5.40 ^c	118.3 ± 5.80	143.0 ± 9.90 ^{**}
9	121.6 ± 6.40 ^l	118.4 ± 10.00 ^k	125.0 ± 7.60 ^k	133.6 ± 6.00
12	124.4 ± 7.40 ^l	128.6 ± 11.10 ^f	120.0 ± 4.50 ^f	127.8 ± 18.40
15	120.2 ± 11.70 ^l	136.3 ± 10.70 ^e	115.6 ± 10.30 ^f	136.4 ± 8.90
18	129.3 ± 11.90	118.1 ± 14.20	119.4 ± 10.30 ^l	118.3 ± 16.00 ^h
21	134.8 ± 12.50	118.4 ± 11.80	141.8 ± 7.20 ^h	118.5 ± 15.80 ^h
24	140.0 ± 8.30	136.0 ± 10.30	110.0 ± 13.50 ^h	115.3 ± 11.50 ^h
Novel side crossing (frequency)				
0	8.9 ± 0.69 ^j	8.7 ± 0.57 ^c	7.8 ± 0.78	9.2 ± 0.66 ^c
3	7.3 ± 0.66 ^f	7.6 ± 0.75 ^c	8.2 ± 0.59	7.3 ± 0.48 ^j
6	9.5 ± 1.12 ^f	6.0 ± 0.72 ^{*c}	6.8 ± 0.63 [*]	4.3 ± 0.73 ^{**}
9	6.1 ± 1.14 ^l	5.4 ± 0.86 ^k	6.4 ± 0.64 ^k	3.7 ± 0.63
12	6.2 ± 0.43 ^l	3.6 ± 0.47 ^{**f}	6.0 ± 0.84 ^f	2.6 ± 0.54 ^{**}
15	5.0 ± 0.67 ^l	2.5 ± 0.40 ^{*e}	5.1 ± 0.87 ^f	3.0 ± 0.65
18	6.0 ± 1.26	5.3 ± 0.89	6.5 ± 0.91 ^l	3.2 ± 0.65 ^h
21	4.0 ± 0.63	3.0 ± 0.31	5.0 ± 0.93 ^h	2.3 ± 0.80 ^h
24	3.7 ± 0.84	3.4 ± 0.92	5.5 ± 0.67 ^h	4.5 ± 0.50 ^h
Locomotor activity (instrument units)				
0	187 ± 5.2 ^j	193 ± 3.8 ^c	192 ± 4.4	191 ± 5.3 ^c
3	185 ± 6.5 ^j	187 ± 4.7 ^c	187 ± 5.7	173 ± 6.2 ^l
6	187 ± 3.5 ^f	168 ± 5.0 ^{*j}	166 ± 8.5 [*]	135 ± 9.5 ^{**}
9	172 ± 6.0 ^l	160 ± 6.9 ^k	159 ± 5.6 ^k	154 ± 10.0
12	166 ± 6.3 ^l	140 ± 6.7 ^{**f}	152 ± 5.2 ^{*f}	125 ± 16.3 ^{**}
15	149 ± 8.1 ^l	125 ± 7.8 ^c	143 ± 6.9 ^f	129 ± 8.9
18	166 ± 10.7	140 ± 7.3	170 ± 4.7 ^g	149 ± 18.3 ^h
21	137 ± 12.0	117 ± 6.4	138 ± 6.1 ^h	114 ± 13.3 ^h
24	129 ± 6.2	125 ± 15.0	150 ± 1.2 ^h	117 ± 6.8 ^h
Forelimb grip strength (g)				
0	63.6 ± 4.11 ^j	64.2 ± 5.17 ^c	63.4 ± 6.82	60.3 ± 5.16 ^c
3	90.7 ± 7.55 ^l	91.4 ± 3.57 ^c	95.6 ± 4.85	100.3 ± 3.70 ^j
6	103.5 ± 5.10 ^l	101.7 ± 4.50 ^c	101.0 ± 4.30	106.7 ± 3.50
9	90.8 ± 6.74 ^l	86.5 ± 5.18 ^f	96.5 ± 6.87 ^k	102.5 ± 3.87
12	94.8 ± 5.23 ^l	96.4 ± 4.74 ^f	89.9 ± 6.46 ^f	109.3 ± 4.29
15	101.8 ± 5.69 ^l	93.9 ± 5.56 ^k	101.0 ± 6.99 ^l	107.0 ± 7.12
18	91.4 ± 4.72	98.3 ± 4.02	107.7 ± 5.42 ^{*l}	101.9 ± 6.82 ^h
21	98.9 ± 6.74	109.0 ± 5.24	99.7 ± 7.52 ^h	103.3 ± 8.74 ^h
24	102.5 ± 2.61	91.2 ± 3.42	100.0 ± 5.10 ^h	110.0 ± 5.06 ^h

TABLE D3
Neurobehavioral Data for Mice in the 2-Year Inhalation Studies of Methyl Bromide (continued)

Parameter/Month	0 ppm	10 ppm	33 ppm	100 ppm
Female (continued)				
Number examined	6	7	16	10
Hind limb grip strength (g)				
0	24.2 ± 2.43 ^j	27.9 ± 3.70 ^c	28.8 ± 3.40	26.7 ± 2.85 ^c
3	60.2 ± 4.74 ^l	57.3 ± 3.63 ^c	58.2 ± 3.42	79.5 ± 4.69 ^{**j}
6	72.4 ± 7.06 ^f	74.4 ± 3.54 ^c	76.3 ± 4.40	88.7 ± 4.99
9	73.3 ± 7.49 ^l	75.4 ± 5.90 ^f	86.1 ± 6.12 ^k	90.7 ± 2.37
12	96.9 ± 4.08 ^l	92.3 ± 4.01 ^f	94.3 ± 4.13 ^f	94.0 ± 4.61
15	73.7 ± 4.88 ^l	67.9 ± 7.14 ^k	79.0 ± 3.12 ^f	73.8 ± 5.04
18	76.4 ± 8.74	77.9 ± 7.58	85.6 ± 4.64 ^l	85.3 ± 9.32 ^h
21	77.5 ± 5.10	84.5 ± 4.93	78.4 ± 6.30 ^h	93.0 ± 11.86 ^h
24	87.8 ± 8.38	80.2 ± 4.90	89.7 ± 8.85 ^h	87.0 ± 13.54 ^h
Hot plate latency (sec)				
0	7.9 ± 0.51 ^j	7.1 ± 0.41 ^c	7.3 ± 0.63	7.1 ± 0.43 ^c
3	7.9 ± 0.62 ^l	8.1 ± 0.72 ^c	8.1 ± 0.83	11.0 ± 1.21 ^{*j}
6	6.7 ± 0.49 ^f	7.8 ± 0.68 ^c	7.1 ± 0.81 ^k	9.4 ± 0.90
9	9.2 ± 0.88 ^l	9.5 ± 1.01 ^f	8.3 ± 1.03 ^k	7.6 ± 1.34
12	9.1 ± 1.13 ^l	8.1 ± 0.83 ^f	7.9 ± 0.77 ^f	7.7 ± 0.38
15	7.2 ± 0.74 ^l	8.7 ± 0.80 ^k	7.0 ± 0.95 ^f	8.1 ± 1.03
18	11.8 ± 2.22	8.2 ± 0.94	8.8 ± 1.24 ^l	8.7 ± 1.54 ^h
21	8.1 ± 1.79	9.2 ± 1.06	7.3 ± 1.32 ^h	8.4 ± 1.40 ^h
24	8.0 ± 0.55	7.5 ± 0.49	6.2 ± 0.60 ^h	8.3 ± 1.71 ^h
Hind limb footsplay (cm)				
0	4.8 ± 0.18 ^f	4.7 ± 0.17 ^c	5.0 ± 0.15 ^j	4.8 ± 0.13 ^c
3	5.2 ± 0.15 ^l	5.5 ± 0.20 ^c	5.0 ± 0.10	5.5 ± 0.50 ^m
6	5.3 ± 0.16 ^f	5.4 ± 0.14 ^c	5.4 ± 0.09 ^c	
9	5.5 ± 0.25 ^l	5.3 ± 0.13 ^f	5.3 ± 0.25 ^f	
12	5.1 ± 0.13 ^l	5.1 ± 0.16 ^k	4.9 ± 0.11 ^f	
15	5.0 ± 0.21 ^l	5.2 ± 0.13 ^k	5.3 ± 0.11 ^f	5.3 ± 0.64 ⁿ
18	5.2 ± 0.12	5.4 ± 0.20	5.4 ± 0.13 ^l	4.4 ± 0.70 ^o
21	5.4 ± 0.25	5.4 ± 0.18 ^h	5.0 ± 0.24 ^h	
24	4.6 ± 0.35	4.9 ± 0.22	5.0 ± 0.15 ^h	

* Significantly different ($P \leq 0.05$) from the control group by Dunn's or Shirley's test

** $P \leq 0.01$

a Mean ± standard error

b Except where noted

c n=16

d n=13

e n=10

f n=12

g n=7

h n=6

i n=9

j n=15

k n=11

l n=8

m n=2

n n=3

o n=4

APPENDIX E

HEMATOLOGY AND PSEUDOCHOLINESTERASE RESULTS

TABLE E1	Hematology Data for Rats in the 13-Week Inhalation Studies of Methyl Bromide	160
TABLE E2	Hematology and Pseudocholinesterase Data for Mice in the 13-Week Inhalation Studies of Methyl Bromide	161
TABLE E3	Hematology Data for Mice at the 6-Month, 15-Month, and Terminal Evaluations of the 2-Year Inhalation Studies of Methyl Bromide	163

TABLE E1
Hematology Data for Rats in the 13-Week Inhalation Studies of Methyl Bromide^a

Analysis	0 ppm	30 ppm	60 ppm	120 ppm
Male				
Number weighed	10	10	8	9
Hematocrit (%)	47.8 ± 0.4	47.7 ± 0.2	47.6 ± 0.3 ^d	47.1 ± 0.4
Hemoglobin (g/dL)	15.8 ± 0.2 ^d	15.9 ± 0.1	15.8 ± 0.1	15.6 ± 0.1
Erythrocytes (10 ⁶ /μL)	9.46 ± 0.08 ^c	9.71 ± 0.09	9.20 ± 0.09	9.37 ± 0.09
Mean cell volume (fL)	50.4 ± 0.4 ^d	49.1 ± 0.4	51.5 ± 0.4	50.3 ± 0.5
Mean cell hemoglobin (pg)	16.6 ± 0.1 ^d	16.4 ± 0.1	17.2 ± 0.1 ^{**}	16.7 ± 0.2
Mean cell hemoglobin concentration (g/dL)	33.0 ± 0.2 ^e	33.4 ± 0.1	33.3 ± 0.2	33.1 ± 0.1 ^e
Leukocytes (10 ³ /μL)	8.08 ± 0.48	8.16 ± 0.13	7.89 ± 0.47	8.92 ± 0.30 ^c
Female				
Number weighed	10	10	10	10
Hematocrit (%)	45.3 ± 0.3	44.2 ± 0.8 ^d	43.9 ± 0.5	43.9 ± 0.3 [*]
Hemoglobin (g/dL)	15.3 ± 0.2 ^d	14.0 ± 0.3	14.9 ± 0.2 ^d	14.6 ± 0.1 ^{**}
Erythrocytes (10 ⁶ /μL)	8.40 ± 0.05	8.30 ± 0.13	7.92 ± 0.08 ^{**}	8.00 ± 0.12 ^{**}
Mean cell volume (fL)	54.0 ± 0.4	53.4 ± 0.4 ^d	55.4 ± 0.5	55.1 ± 0.5
Mean cell hemoglobin (pg)	18.2 ± 0.2 ^d	18.1 ± 0.1	18.8 ± 0.2 ^d	18.3 ± 0.2
Mean cell hemoglobin concentration (g/dL)	33.8 ± 0.3 ^d	33.9 ± 0.2 ^d	34.0 ± 0.1 ^d	33.3 ± 0.1
Leukocytes (10 ³ /μL)	6.15 ± 0.20	6.31 ± 0.24	6.75 ± 0.14	6.54 ± 0.19

* Significantly different ($P \leq 0.05$) from the control group by Dunn's or Shirley's test

** $P \leq 0.01$

^a Mean ± standard error

^b n=10

^c n=9

^d n=8

TABLE E2
Hematology and Pseudocholinesterase Data for Mice in the 13-Week Inhalation Studies
of Methyl Bromide^a

Analysis	0 ppm	10 ppm	20 ppm	40 ppm
Male				
Number weighed	9	10	8	8
Hematocrit (%)	46.5 ± 1.2 ^c	49.3 ± 0.7	48.1 ± 1.0 ^c	50.0 ± 0.9 ^c
Hemoglobin (g/dL)	15.2 ± 0.4	16.1 ± 0.3	16.0 ± 0.4 ^c	16.3 ± 0.3 ^c
Erythrocytes (10 ⁶ /μL)	7.72 ± 0.31 ^c	7.44 ± 0.17	7.66 ± 0.20 ^c	9.19 ± 0.26 ^{**c}
Mean cell volume (fL)	60.9 ± 2.5 ^c	66.4 ± 1.4	63.0 ± 0.7 ^c	54.6 ± 0.9 ^{**c}
Mean cell hemoglobin (pg)	20.2 ± 1.0	21.7 ± 0.5	20.9 ± 0.2 ^c	17.8 ± 0.3 ^{**c}
Mean cell hemoglobin concentration (g/dL)	32.6 ± 0.7	32.6 ± 0.3	33.1 ± 0.3 ^c	32.6 ± 0.4 ^c
Leukocytes (10 ³ /μL)	7.17 ± 0.84	7.44 ± 0.92	10.81 ± 1.30 ^c	6.91 ± 0.58 ^c
Pseudocholinesterase (IU/mL)	6.0 ± 0.5 ^c	6.8 ± 0.6	7.2 ± 0.7 ^c	7.2 ± 0.5 ^c
Female				
Number weighed	8	8	8	8
Hematocrit (%)	49.8 ± 0.4 ^c	50.7 ± 0.3 ^c	50.8 ± 0.4 ^c	50.7 ± 0.3 ^c
Hemoglobin (g/dL)	16.6 ± 0.2 ^c	16.6 ± 0.2 ^c	16.8 ± 0.3 ^c	16.7 ± 0.2 ^c
Erythrocytes (10 ⁶ /μL)	9.80 ± 0.09 ^c	8.07 ± 0.26 ^{**c}	8.72 ± 0.16 ^{**c}	10.31 ± 0.14 ^c
Mean cell volume (fL)	50.8 ± 0.7 ^c	63.4 ± 1.9 ^{**c}	58.4 ± 0.8 ^{**c}	49.2 ± 0.7 ^{**c}
Mean cell hemoglobin (pg)	17.0 ± 0.2 ^c	20.7 ± 0.5 ^c	19.3 ± 0.4 ^c	16.2 ± 0.2 ^c
Mean cell hemoglobin concentration (g/dL)	33.4 ± 0.4 ^c	32.7 ± 0.5 ^c	33.0 ± 0.6 ^c	32.9 ± 0.4 ^c
Leukocytes (10 ³ /μL)	6.00 ± 0.38 ^c	6.51 ± 0.36 ^c	9.05 ± 0.62 ^{**c}	7.49 ± 0.77 ^{**c}
Pseudocholinesterase (IU/mL)	8.4 ± 0.4 ^c	8.5 ± 0.5 ^c	8.0 ± 0.6 ^d	8.7 ± 0.6 ^c

TABLE E2
Hematology and Pseudocholinesterase Data for Mice in the 13-Week Inhalation Studies
of Methyl Bromide^a (continued)

Analysis	0 ppm	80 ppm	120 ppm
Male (continued)			
Number weighed ^b	9	8	8
Hematocrit (%)	46.5 ± 1.2 ^c	47.9 ± 0.7	50.5 ± 0.8 ^d
Hemoglobin (g/dL)	15.2 ± 0.4	15.6 ± 0.3	16.7 ± 0.4** ^d
Erythrocytes (10 ⁶ /μL)	7.72 ± 0.31 ^c	8.78 ± 0.23**	10.34 ± 0.21** ^c
Mean cell volume (fL)	60.9 ± 2.5 ^c	54.7 ± 1.2*	48.8 ± 1.0** ^d
Mean cell hemoglobin (pg)	20.2 ± 1.0	17.8 ± 0.3*	16.1 ± 0.2** ^d
Mean cell hemoglobin concentration (g/dL)	32.6 ± 0.7	32.6 ± 0.4	33.2 ± 0.6 ^d
Leukocytes (10 ³ /μL)	7.17 ± 0.84	9.39 ± 0.79	6.87 ± 0.76 ^c
Pseudocholinesterase (IU/mL)	6.0 ± 0.5 ^c	7.2 ± 0.8	7.0 ± 0.4 ^c
Female (continued)			
Number weighed	8	8	8
Hematocrit (%)	49.8 ± 0.4 ^c	52.1 ± 0.3**	48.7 ± 0.3 ^c
Hemoglobin (g/dL)	16.6 ± 0.2 ^c	16.5 ± 0.3	15.9 ± 0.3 ^c
Erythrocytes (10 ⁶ /μL)	9.80 ± 0.09 ^c	9.54 ± 0.20	10.07 ± 0.18 ^c
Mean cell volume (fL)	50.8 ± 0.7 ^c	54.7 ± 1.2*	48.5 ± 0.8 ^c
Mean cell hemoglobin (pg)	17.0 ± 0.2 ^c	17.4 ± 0.2	15.8 ± 0.1* ^c
Mean cell hemoglobin concentration (g/dL)	33.4 ± 0.4 ^c	31.8 ± 0.5*	32.6 ± 0.5 ^c
Leukocytes (10 ³ /μL)	6.00 ± 0.38 ^c	9.66 ± 0.59**	6.68 ± 0.50* ^c
Pseudocholinesterase (IU/mL)	8.4 ± 0.4 ^c	9.0 ± 0.9	8.6 ± 0.2 ^c

* Significantly different (P<0.05) from the control group by Dunn's or Shirley's test

** P≤0.01

^a Mean ± standard error

^b Except where noted

^c n=10

^d n=9

^e n=6

^f n=8

^g n=4

^h n=7

TABLE E3
Hematology Data for Mice at the 6-Month, 15-Month, and Terminal Evaluations
of the 2-Year Inhalation Studies of Methyl Bromide^a

Analysis	0 ppm	10 ppm	33 ppm	100 ppm
Male				
Number weighed ^b	9	9	10	14
Hematocrit (%)				
6 month	46.1 ± 0.5	46.9 ± 0.4	47.2 ± 0.7 ^d	NT
15 month	46.7 ± 1.7	43.2 ± 3.0	45.2 ± 0.5	NT
24 month	46.7 ± 1.1 ^e	45.7 ± 1.2 ^f	46.0 ± 1.0 ^g	46.9 ± 2.9
Hemoglobin (g/dL)				
6 month	16.0 ± 0.3 ^c	16.3 ± 0.2	16.2 ± 0.2 ^d	NT
15 month	15.7 ± 0.6	14.5 ± 1.2 ^f	15.4 ± 0.2	NT
24 month	15.6 ± 0.4 ^e	15.2 ± 0.4 ^f	15.2 ± 0.3 ^g	15.4 ± 1.0
Erythrocytes (10 ⁶ /μL)				
6 month	9.37 ± 0.20 ^j	9.38 ± 0.31	9.41 ± 0.42 ^k	NT
15 month	10.30 ± 0.49	9.60 ± 0.73	9.78 ± 0.13	NT
24 month	10.23 ± 0.28 ^e	10.08 ± 0.35 ^f	10.12 ± 0.28 ^g	10.28 ± 0.81
Mean cell volume (fL)				
6 month	49.3 ± 1.3 ^j	50.3 ± 1.6	50.4 ± 1.7 ^k	NT
15 month	45.5 ± 0.4	45.2 ± 0.6	46.3 ± 0.2	NT
24 month	45.9 ± 0.3 ^e	45.7 ± 0.4 ^f	45.7 ± 0.4 ^g	47.4 ± 1.9
Mean cell hemoglobin (pg)				
6 month	17.0 ± 0.5 ^j	17.5 ± 0.4	17.3 ± 0.6 ^k	NT
15 month	15.3 ± 0.2	15.0 ± 0.4 ^f	15.7 ± 0.1	NT
24 month	15.3 ± 0.1 ^e	15.2 ± 0.2 ^f	15.3 ± 0.1 ^g	15.4 ± 0.5
Mean cell hemoglobin concentration (g/dL)				
6 month	34.7 ± 0.3 ^c	34.9 ± 0.3	34.3 ± 0.1 ^d	NT
15 month	33.7 ± 0.4	33.1 ± 0.8	34.0 ± 0.1	NT
24 month	33.3 ± 0.1 ^e	33.3 ± 0.1 ^f	33.4 ± 0.1 ^g	32.6 ± 0.4
Platelets (10 ³ /μL)				
6 month	931.8 ± 79.9 ^j	816.8 ± 73.7 ^j	873.3 ± 96.3 ^d	NT
15 month	1,263.0 ± 69.0	1,352.0 ± 121.0	1,454.0 ± 44.0*	NT
24 month	1,467.0 ± 44.0 ^f	1,413.0 ± 74.0 ^f	1,546.0 ± 62.0 ^e	1,352.0 ± 105.0 ^l
Reticulocytes (10 ⁶ /μL)				
6 month	0.0 ± 0.0 ^j	0.0 ± 0.0	0.0 ± 0.0 ^k	NT
15 month	0.3 ± 0.0	0.3 ± 0.0 ^f	0.3 ± 0.0	NT
24 month	0.2 ± 0.0 ^e	0.2 ± 0.0 ^f	0.2 ± 0.0 ^g	0.2 ± 0.0
Leukocytes (10 ³ /μL)				
6 month	3.81 ± 0.60 ^c	3.88 ± 0.43	4.65 ± 0.99 ^d	NT
15 month	4.22 ± 0.60	3.97 ± 0.79	4.62 ± 0.42	NT
24 month	7.09 ± 0.34 ^e	7.04 ± 0.30 ^f	6.89 ± 0.53 ^g	7.09 ± 1.18

TABLE E3
Hematology Data for Mice at the 6-Month, 15-Month, and Terminal Sacrifices
of the 2-Year Inhalation Studies of Methyl Bromide^a (continued)

Analysis	0 ppm	10 ppm	33 ppm	100 ppm
Male (continued)				
Number weighed	9	9	10	14
Segmented neutrophils ($10^3/\mu\text{L}$)				
6 month	0.41 ± 0.07 ^c	0.47 ± 0.15	0.65 ± 0.11 ^d	NT
15 month	1.00 ± 0.11	1.17 ± 0.30	1.27 ± 0.37	NT
24 month	2.11 ± 0.27 ^e	1.93 ± 0.15 ^f	2.36 ± 0.40 ^g	3.06 ± 1.04
Lymphocytes ($10^3/\mu\text{L}$)				
6 month	2.75 ± 0.46 ^c	2.82 ± 0.38	3.38 ± 0.87 ^d	NT
15 month	3.00 ± 0.45	2.57 ± 0.47 ^f	3.13 ± 0.28	NT
24 month	4.41 ± 0.23 ^e	4.42 ± 0.23 ^f	3.84 ± 0.25 ^g	3.48 ± 0.45*
Monocytes ($10^3/\mu\text{L}$)				
6 month	0.58 ± 0.08 ^c	0.52 ± 0.06	0.58 ± 0.18 ^d	NT
15 month	0.17 ± 0.04	0.17 ± 0.05 ^f	0.19 ± 0.03	NT
24 month	0.48 ± 0.05 ^e	0.52 ± 0.05 ^f	0.56 ± 0.12 ^g	0.41 ± 0.08
Eosinophils ($10^3/\mu\text{L}$)				
6 month	0.08 ± 0.02 ^c	0.05 ± 0.02	0.03 ± 0.01 ^d	NT
15 month	0.05 ± 0.02	0.06 ± 0.02	0.04 ± 0.02	NT
24 month	0.08 ± 0.01 ^e	0.06 ± 0.01 ^f	0.07 ± 0.01 ^g	0.15 ± 0.05
Female				
Number weighed	9	10	10	8
Hematocrit (%)				
6 month	47.4 ± 0.4 ^c	NT	47.3 ± 0.3 ^c	NT
15 month	45.2 ± 0.3	45.6 ± 0.5	45.3 ± 0.4	47.3 ± 0.3**
24 month	44.4 ± 0.6 ^m	44.7 ± 1.0 ^g	45.3 ± 0.7 ^p	45.3 ± 0.4 ^o
Hemoglobin (g/dL)				
6 month	16.4 ± 0.2 ^c	16.4 ± 0.2	16.5 ± 0.1 ^c	NT
15 month	15.6 ± 0.1	15.7 ± 0.2	15.5 ± 0.1	16.2 ± 0.1*
24 month	14.9 ± 0.2 ^m	15.1 ± 0.3 ^g	15.0 ± 0.4 ^p	15.2 ± 0.1 ^o
Erythrocytes ($10^6/\mu\text{L}$)				
6 month	9.82 ± 0.23 ^j	9.39 ± 0.24	9.30 ± 0.26 ^c	NT
15 month	9.86 ± 0.09	9.83 ± 0.11	9.82 ± 0.09	10.50 ± 0.09**
24 month	9.46 ± 0.16 ^m	9.69 ± 0.29 ^g	9.59 ± 0.19 ^p	9.86 ± 0.12 ^o
Mean cell volume (fL)				
6 month	48.1 ± 0.72 ^j	50.0 ± 1.42	51.2 ± 1.58 ^c	NT
15 month	45.9 ± 0.28	46.4 ± 0.15	46.1 ± 0.12	45.0 ± 0.18 ^o
24 month	47.2 ± 0.4 ^m	46.8 ± 0.6 ^g	47.5 ± 0.6 ^p	46.0 ± 0.2 ^o

TABLE E3
Hematology Data for Mice at the 6-Month, 15-Month, and Terminal Sacrifices
of the 2-Year Inhalation Studies of Methyl Bromide^a (continued)

Analysis	0 ppm	10 ppm	33 ppm	100 ppm
Female (continued)				
Number weighed	9	10	10	8
Mean cell hemoglobin (pg)				
6 month	16.6 ± 0.3 ^j	17.6 ± 0.4	17.8 ± 0.5 ^c	NT
15 month	15.8 ± 0.1	15.9 ± 0.1	15.8 ± 0.1	15.4 ± 0.1*
24 month	15.8 ± 0.2 ^m	15.8 ± 0.2 ^g	15.7 ± 0.3 ^p	15.4 ± 0.1 ^{**o}
Mean cell hemoglobin concentration (g/dL)				
6 month	34.6 ± 0.3 ^c	35.0 ± 0.3	34.8 ± 0.1 ^c	NT
15 month	34.5 ± 0.1	34.4 ± 0.1	34.2 ± 0.1	34.2 ± 0.1
24 month	33.6 ± 0.3 ^m	33.8 ± 0.1 ^g	33.1 ± 0.6 ^p	33.5 ± 0.1 ^o
Platelets (10 ³ /μL)				
6 month	992.5 ± 47.6 ^j	838.0 ± 55.5	1,006.3 ± 85.1	NT
15 month	1,177.0 ± 32.0	1,223.0 ± 22.0	1,181.0 ± 42.0	1,283.0 ± 56.0*
24 month	1,059.0 ± 31.0 ^m	1,064.0 ± 58.0 ^e	1,064.0 ± 38.0 ^p	1,170.0 ± 36.0 ^o
Reticulocytes (10 ⁶ /μL)				
6 month	0.0 ± 0.0 ^j	0.0 ± 0.0	0.0 ± 0.0 ^c	NT
15 month	0.3 ± 0.0	0.2 ± 0.0	0.3 ± 0.0	0.3 ± 0.0
24 month	0.2 ± 0.0 ^m	0.2 ± 0.0 ^g	0.2 ± 0.0 ^p	0.2 ± 0.0 ^o
Leukocytes (10 ³ /μL)				
6 month	3.64 ± 0.39 ^c	3.90 ± 0.43	3.71 ± 0.38 ^c	NT
15 month	2.93 ± 0.33	3.30 ± 0.38	2.87 ± 0.37	5.45 ± 1.31
24 month	4.74 ± 0.41 ^m	5.05 ± 0.54 ^g	4.98 ± 0.63 ⁿ	5.39 ± 0.40 ^o
Segmented neutrophils (10 ³ /μL)				
6 month	0.40 ± 0.05 ^c	0.44 ± 0.12	0.48 ± 0.08 ^c	NT
15 month	0.88 ± 0.11	0.88 ± 0.10	0.80 ± 0.12	1.12 ± 0.22 ^c
24 month	1.33 ± 0.20 ^m	1.46 ± 0.19 ^g	1.21 ± 0.13 ⁿ	1.66 ± 0.18 ^o
Lymphocytes (10 ³ /μL)				
6 month	2.54 ± 0.35 ^c	2.82 ± 0.31	2.64 ± 0.33 ^c	NT
15 month	1.90 ± 0.21	2.21 ± 0.30	1.93 ± 0.25	4.11 ± 1.12*
24 month	2.95 ± 0.28 ^m	3.03 ± 0.34 ^g	3.15 ± 0.44 ^p	3.17 ± 0.26 ^c
Monocytes (10 ³ /μL)				
6 month	0.62 ± 0.08 ^c	0.59 ± 0.07	0.53 ± 0.04 ^c	NT
15 month	0.12 ± 0.02	0.08 ± 0.12	0.08 ± 0.02	0.16 ± 0.03
24 month	0.38 ± 0.04 ^m	0.46 ± 0.13 ^g	0.34 ± 0.06 ^p	0.41 ± 0.05 ^e
Eosinophils (10 ³ /μL)				
6 month	0.08 ± 0.02 ^c	0.04 ± 0.01	0.05 ± 0.02 ^c	NT
15 month	0.04 ± 0.01	0.06 ± 0.01	0.07 ± 0.01	0.06 ± 0.03 ^o
24 month	0.06 ± 0.01 ^m	0.05 ± 0.01 ^g	0.06 ± 0.01 ⁿ	0.10 ± 0.02 ^o

TABLE E3
Hematology Data for Mice at the 6-Month, 15-Month, and Terminal Sacrifices
of the 2-Year Inhalation Studies of Methyl Bromide^a (continued)

NT Measurements of the parameter not taken at this dose level.

* Significantly different ($P \leq 0.05$) from the control group by Dunn's or Shirley's test

** $P \leq 0.01$

^a Mean \pm standard error

^b Except where noted

^c n=8

^d n=6

^e n=39

^f n=37

^g n=40

^h n=10

ⁱ n=15

^j n=7

^k n=5

^l n=13

^m n=36

ⁿ n=44

^o n=38

^p n=45

APPENDIX F

GENETIC TOXICOLOGY

<i>SALMONELLA</i> DESICCATOR PROTOCOL	168
<i>IN VIVO</i> MOUSE BONE MARROW SISTER CHROMATID EXCHANGE TEST	168
MOUSE PERIPHERAL BLOOD MICRONUCLEUS TEST	169
RESULTS	169
TABLE F1 Mutagenicity of Methyl Bromide in <i>Salmonella typhimurium</i>	170
TABLE F2 Cytogenetic and Micronuclei Data for Mice in the 14-Day Inhalation Studies of Methyl Bromide	172
TABLE F3 Cytogenetic and Micronuclei Data for Mice in the 12-Week Inhalation Studies of Methyl Bromide	173

GENETIC TOXICOLOGY

***Salmonella* Desiccator Protocol for Testing Methyl Bromide**

A modification of the technique reported by Zeiger (1990) was used to adequately expose the bacteria to gaseous methyl bromide. Methyl bromide was sent to the laboratory coded from Radian Corporation (Austin, TX). The minimal glucose agar plates with the *Salmonella typhimurium* tester strains (TA98, TA100) alone or with S9 mix (metabolic activation enzymes and cofactors from Aroclor 1254-induced male Sprague-Dawley rat or Syrian hamster liver) were placed, without lids, in glass desiccator jars. The desiccators were then sealed and partially evacuated to allow for addition of the gas/air mixture. Methyl bromide was equilibrated with air and introduced through valves into the sealed desiccators. The entire apparatus was incubated at 37°C for 48 hours.

Each trial consisted of triplicate plates of concurrent positive and negative controls and 2 to 5 doses of methyl bromide. High dose was limited by toxicity. All negative assays were repeated, and all positive assays were repeated under the conditions which elicited the positive response.

A positive response is defined as a reproducible, dose-related increase in histidine-independent (revertant) colonies in any one strain/activation combination. An equivocal response is defined as an increase in revertants which is not dose-related, not reproducible, or of insufficient magnitude to support a determination of mutagenicity. A negative response is obtained when no increase in revertant colonies is observed following chemical treatment.

***In Vivo* Mouse Bone Marrow Sister Chromatid Exchange Test**

The maximum concentration of methyl bromide was set at 200 ppm in the 14-day exposure test and at 120 ppm in the 12-week study. In the 14-day studies, five male and female B6C3F₁ mice were exposed to 0, 12, 25, 50, 100, or 200 ppm methyl bromide for 6 hours per day, 5 days per week for a total of 10 exposures. In the 12-week studies, four male and female B6C3F₁ mice were exposed to 0, 10, 20, 40, 80, or 120 ppm methyl bromide, 6 hours per day, 5 days per week for 12 weeks. Twenty-four hours prior to cell harvest, the mice were implanted subcutaneously with a 50 mg bromodeoxyuridine (BrdU) tablet (McFee *et al.*, 1983), and two hours prior to sacrifice, the mice received an IP injection of 2 mg/kg colchicine (in saline). After sacrifice, one or both femurs were removed and the marrow was flushed out with 5 mL PBS (pH 7.0). The cells were treated with a hypotonic salt solution, fixed, and dropped onto chilled slides. Following a 24-hour drying period, the slides were stained by the fluorescence-plus-Giemsa method and scored. Twenty-five second-division metaphase cells were scored per animal. Responses were evaluated as the number of sister chromatid exchanges (SCE) per cell. An additional 100 cells per animal were scored for cell cycle kinetics (AGT values). Square-root transformed SCE data and cell cycle data were analyzed by one-way analysis of variance with tests for regression to determine whether the slope of the dose-response curve was equal to zero. Student's t-test was used to determine significance of pairwise comparison of individual dose levels to the control.

Mouse Peripheral Blood Micronucleus Test

Peripheral blood samples were collected from four male and female B6C3F₁ mice from each exposure group at the end of the 14-day study and at 4-, 8-, and 12-week interims during the 13-week subchronic study. Smears were prepared and fixed in absolute methanol. The methanol-fixed slides were stained with acridine orange and coded. Slides were scanned to determine the frequency of micronuclei in normochromatic erythrocytes (NCE) and polychromatic erythrocytes (PCE) per animal. The criteria of Schmid (1976) were used in defining micronuclei. Micronucleus data were analyzed by Kruskal-Wallis one-way analysis of variance to determine whether the slope of the dose-response curve was equal to zero. The Mann-Whitney U test was used to ascertain those doses at which a significant increase in micronuclei above control levels occurred.

RESULTS

Methyl bromide, tested within a sealed desiccator to ensure adequate exposure, was mutagenic in *Salmonella typhimurium* strain TA100, with and without Aroclor 1254-induced male Sprague-Dawley rat liver or Syrian hamster liver S9; no mutagenic response was observed in TA98 tested under identical conditions (Table F1). Doses tested ranged from 0.0004 to 2.4 moles/L; slight to severe toxicity was noted at doses of 0.120 moles/L and above.

Methyl bromide induced SCE in bone marrow cells and micronuclei in peripheral erythrocytes of B6C3F₁ female mice exposed over a 14-day period for 6 hours per day, 5 days per week (Table F2). Elevated responses in the micronucleus test were obtained over the entire dose range (12 to 200 ppm), with the greatest responses seen at the two highest doses tested (100 and 200 ppm). In the SCE test, a dose response was observed and an increase of two SCE/cell was seen at the highest dose. In male mice exposed for 14 days to methyl bromide, a dose response was seen in the SCE test, although the magnitude at the highest dose (1 SCE per cell) was less than that observed in female mice. Likewise, in the 14-day micronucleus test with male mice, small increases were noted in the 25, 50, and 100 ppm dose groups, but analysis of the response across doses indicated less significance than the response noted in females. Therefore, these test results in male mice were considered to be equivocal. Average generation time (AGT), used as a measure of bone marrow cell cycle kinetics, was unaffected in male and female mice, even at the highest dose levels tested.

Groups of male and female B6C3F₁ mice exposed to methyl bromide for a 12-week period were examined for induction of SCE in bone marrow cells and micronuclei in peripheral erythrocytes. All tests were negative (Table F3). In addition, methyl bromide exposure produced no effect on bone marrow cell kinetics, as indicated by the average generation time (AGT) values. The percentage of PCEs in the peripheral blood was unaltered by methyl bromide exposure, indicating lack of either stimulation or suppression of erythropoiesis.

TABLE F1
Mutagenicity of Methyl Bromide in *Salmonella typhimurium*^a

Strain	Dose (moles/L)	Revertants/plate ^b					
		-S9			+30% hamster S9		
		Trial 1	Trial 2	Trial 3	Trial 1	Trial 2	Trial 3
TA100	0.000	106 ± 6.8	166 ± 6.9	129 ± 12.7	115 ± 9.0	162 ± 3.2	178 ± 9.0
	0.004			518 ± 24.4			796 ± 5.4
	0.012			510 ± 29.7			632 ± 3.1
	0.040			430 ± 5.2			577 ± 12.0
	0.120		602 ± 6.1	3 ± 0.9 ^c		871 ± 8.7	14 ± 1.3 ^c
	0.300	673 ± 19.2			650 ± 27.5		
	0.400		Toxic			0 ± 0.0 ^c	
	0.600	2 ± 0.7 ^c			4 ± 0.3 ^c		
	0.900	Toxic			Toxic		
	0.980		Toxic			Toxic	
	1.200	Toxic	Toxic		Toxic	Toxic	
	2.400	Toxic			Toxic		
	Trial summary		Positive	Positive	Positive	Positive	Positive
Positive control ^d		621 ± 10.2	363 ± 11.9	324 ± 3.0	539 ± 25.1	736 ± 22.2	516 ± 17.3
TA100 (continued)		+ 30% rat S9					
		Trial 1	Trial 2	Trial 3			
	0.000	140 ± 9.2	172 ± 11.9	190 ± 11.0			
	0.004			786 ± 34.4			
	0.012			670 ± 55.2			
	0.040			592 ± 24.5			
	0.120		811 ± 3.2	21 ± 2.7 ^c			
	0.300	567 ± 32.1					
	0.400		0 ± 0.0 ^c				
	0.600	13 ± 2.3 ^c					
	0.900	Toxic					
	0.980		Toxic				
	1.200	Toxic	Toxic				
	2.400	Toxic					
Trial summary		Positive	Positive	Positive			
Positive control		1,026 ± 85.1	701 ± 1.5	929 ± 45.0			

TABLE F1
Mutagenicity of Methyl Bromide in *Salmonella typhimurium* (continued)

Strain	Dose (moles/L)	Revertants/plate					
		-S9			+30% hamster S9		
		Trial 1	Trial 2	Trial 3	Trial 1	Trial 2	Trial 3
TA98	0.000	13 ± 1.2	26 ± 3.7	25 ± 2.9	26 ± 3.2	33 ± 3.2	29 ± 3.7
	0.004			14 ± 1.9			21 ± 3.0
	0.012			13 ± 1.2			16 ± 6.1
	0.040			3 ± 0.6			9 ± 1.7
	0.120		8 ± 1.8	0 ± 0.0 ^c		10 ± 1.2	1 ± 0.6 ^c
	0.300	8 ± 0.7			9 ± 2.5		
	0.400		0 ± 0.0 ^c			0 ± 0.0 ^c	
	0.600	Toxic			0 ± 0.3 ^c		
	0.900	Toxic			Toxic		
	0.980		Toxic			Toxic	
	1.200	Toxic	Toxic		Toxic	Toxic	
	2.400	Toxic	Toxic		Toxic	Toxic	
	Trial summary		Negative	Negative	Negative	Negative	Negative
Positive control		355 ± 5.1	299 ± 2.7	310 ± 3.5	314 ± 21.4	609 ± 23.8	393 ± 16.5
TA98 (continued)		+ 30% rat S9					
		Trial 1	Trial 2	Trial 3			
TA98	0.000	25 ± 3.9	28 ± 4.7	32 ± 1.2			
	0.004			17 ± 1.7			
	0.012			17 ± 2.0			
	0.040			10 ± 3.0			
	0.120		11 ± 0.7	2 ± 0.3 ^c			
	0.300	11 ± 1.5					
	0.400		0 ± 0.0 ^c				
	0.600	1 ± 0.7					
	0.900	Toxic					
	0.980		Toxic				
	1.200	Toxic	Toxic				
	2.400	Toxic	Toxic				
	Trial summary		Negative	Negative	Negative		
Positive control		372 ± 15.5	350 ± 16.0	294 ± 19.7			

^a Study performed by Microbiological Associates. A description of the desiccator protocol is presented in Zeiger (1990); modifications are described in the Protocol section of this appendix. Cells and methyl bromide or carrier (air) were incubated in the absence of exogenous metabolic activation (-S9) or with Aroclor 1254-induced S9 from male Syrian hamster liver or male Sprague-Dawley rat liver. High dose was limited by toxicity. 0 moles/L dose is the control.

^b Revertants are presented as mean ± standard error from three plates.

^c Slight toxicity

^d Positive control; 2-aminoanthracene was used on all strains in the presence of S9. In the absence of metabolic activation, 4-nitro-*o*-phenylenediamine was tested on TA98 and sodium azide was tested on TA100.

TABLE F2
Cytogenetic and Micronuclei Data for Mice in the 14-Day Inhalation Studies of Methyl Bromide^a

Dose	No. of SCEs ^b	Average Generation Time ^c	Micronuclei/ 1,000 Erythrocytes ^c
Male			
0 ppm	3.7 ± 0.3	13.4 ± 0.1	5.6 ± 0.5
12 ppm	3.4 ± 0.1	12.6 ± 0.2	5.4 ± 0.9
25 ppm	4.3 ± 0.3	12.7 ± 0.4	7.7 ± 1.9
50 ppm	4.4 ± 0.1	12.4 ± 0.2	6.4 ± 1.2
100 ppm	4.3 ± 0.2	12.6 ± 0.2	7.2 ± 1.0
200 ppm ^d	4.8	12.2	4.0
	P=0.021	P=0.224	P=0.622
Female			
0 ppm	3.2 ± 0.2	13.1 ± 0.4	3.0 ± 0.4
12 ppm	3.8 ± 0.5	12.8 ± 0.5	7.0 ± 1.2
25 ppm	3.6 ± 0.3	11.9 ± 0.1	5.0 ± 0.8
50 ppm	3.3 ± 1.1	12.2 ± 0.1	4.5 ± 0.5
100 ppm	4.8 ± 0.1	12.0 ± 0.2	9.0 ± 0.8
200 ppm ^e	5.3 ± 0.1	12.3 ± 0.1	16.0 ± 1.2
	P=0.003	P=0.178	P=0.001

^a Data presented as mean ± standard error. P values are for trend tests as indicated in the Protocol section of this appendix. Significance occurs at P ≤ 0.05.

^b Four animals per dose group; 25 cells scored per animal.

^c Five animals per dose group; 100 cells scored per animal for average generation time determination, and 1,000 erythrocytes per animal scored for micronuclei.

^d Only one animal survived at this dose level. Data are presented but were not used for statistical purposes.

^e One animal died at this dose level.

TABLE F3
Cytogenetic and Micronuclei Data for Mice in the 12-Week Inhalation Studies of Methyl Bromide^a

Analysis	0 ppm	10 ppm	20 ppm	40 ppm
Male				
Sister chromatid exchange	4.2 ± 0.13 ^e	3.6 ± 0.39 ^e	4.1 ± 0.26 ^e	4.0 ± 0.59 ^e
Average generation time	12.1 ± 0.15 ^c	12.3 ± 0.08 ^d	12.0 ± 0.14	12.5 ± 0.14
Micronuclei/normochromatic erythrocyte				
4 weeks	3.7 ± 0.71 ^f	3.0 ± 0.60 ^d	3.5 ± 0.42	2.8 ± 0.49
8 weeks	1.8 ± 0.68 ^d	2.7 ± 0.36 ^f	2.5 ± 0.54	1.3 ± 0.70
12 weeks	3.2 ± 0.48 ^c	2.9 ± 0.69 ^d	2.0 ± 0.33	3.3 ± 0.68
Polychromatic erythrocytes (%)				
4 weeks	4.69 ± 1.196 ^f	2.64 ± 0.377 ^d	2.75 ± 0.256	2.74 ± 0.533
8 weeks	3.05 ± 0.649 ^d	2.57 ± 0.475 ^f	2.63 ± 0.414	2.83 ± 0.673
12 weeks	2.92 ± 0.497 ^c	3.21 ± 0.383 ^d	2.86 ± 0.335	4.36 ± 0.774
Micronuclei/polychromatic erythrocyte				
4 weeks	2.9 ± 0.40 ^f	1.9 ± 0.64 ^d	1.6 ± 0.32	1.5 ± 0.50
8 weeks	2.5 ± 0.78 ^d	1.4 ± 0.37 ^f	2.8 ± 0.70	1.5 ± 0.60
12 weeks	1.8 ± 0.40 ^c	2.1 ± 0.48 ^d	1.1 ± 0.40	2.6 ± 0.65
Female				
Sister chromatid exchange	4.4 ± 0.05 ^e	5.6 ± 0.19 ^e	4.9 ± 0.33 ^e	4.2 ± 0.20 ^e
Average generation time	12.4 ± 0.16	12.3 ± 0.19	12.3 ± 0.09	12.3 ± 0.16
Micronuclei/normochromatic erythrocyte				
4 weeks	1.5 ± 0.19	2.5 ± 0.42	1.8 ± 0.31	1.8 ± 0.25
8 weeks	1.6 ± 0.38	1.8 ± 0.37	1.6 ± 0.46	1.9 ± 0.30
12 weeks	2.3 ± 0.41	3.4 ± 0.89	3.4 ± 0.42	1.8 ± 0.25
Polychromatic erythrocytes (%)				
4 weeks	2.26 ± 0.345	2.71 ± 0.387	2.46 ± 0.215	2.40 ± 0.445
8 weeks	3.21 ± 0.312	4.38 ± 0.650	3.58 ± 0.471	3.31 ± 0.524
12 weeks	2.04 ± 0.283	2.36 ± 0.205	2.70 ± 0.246	1.99 ± 0.277
Micronuclei/polychromatic erythrocyte				
4 weeks	1.8 ± 0.31	2.0 ± 0.63	1.0 ± 0.27	0.6 ± 0.18
8 weeks	1.3 ± 0.16	1.3 ± 0.31	1.4 ± 0.50	1.6 ± 0.32
12 weeks	0.9 ± 0.30	1.6 ± 0.38	1.4 ± 0.38	0.8 ± 0.16

TABLE F3
Cytogenetic and Micronuclei Data for Mice in the 12-Week Inhalation Studies of Methyl Bromide^a
 (continued)

Analysis	0 ppm	80 ppm	120 ppm
Male (continued)			
Sister chromatid exchange	4.2 ± 0.13 ^e	3.9 ± 0.38 ^e	4.1 ± 0.33 ^e
Average generation time	12.1 ± 0.15 ^c	12.2 ± 0.07	12.4 ± 0.16
Micronuclei/normochromatic erythrocyte			
4 weeks	3.7 ± 0.71 ^f	1.4 ± 0.38**	2.6 ± 0.42*
8 weeks	1.8 ± 0.68 ^d	2.1 ± 0.61	1.9 ± 0.30
12 weeks	3.2 ± 0.48 ^c	2.3 ± 0.37	3.6 ± 0.32
Polychromatic erythrocytes (%)			
4 weeks	4.69 ± 1.196 ^f	4.65 ± 0.874	3.44 ± 0.468
8 weeks	3.05 ± 0.649 ^d	3.63 ± 0.953	2.94 ± 0.551
12 weeks	2.92 ± 0.497 ^c	3.24 ± 0.374	3.39 ± 0.511
Micronuclei/polychromatic erythrocyte			
4 weeks	2.9 ± 0.40 ^f	1.9 ± 0.55	2.9 ± 0.55
8 weeks	2.5 ± 0.78 ^d	1.1 ± 0.35	2.1 ± 0.35
12 weeks	1.8 ± 0.40 ^c	1.5 ± 0.19	2.3 ± 0.75
Female (continued)			
Sister chromatid exchange	4.4 ± 0.05 ^e	4.8 ± 0.31 ^e	5.1 ± 0.21 ^e
Average generation time	12.4 ± 0.16	12.2 ± 0.18	12.2 ± 0.12
Micronuclei/normochromatic erythrocyte			
4 weeks	1.5 ± 0.19	0.8 ± 0.25	2.5 ± 0.46
8 weeks	1.6 ± 0.38	1.8 ± 0.41	1.5 ± 0.42
12 weeks	2.3 ± 0.41	1.9 ± 0.30	1.8 ± 0.37
Polychromatic erythrocytes (%)			
4 weeks	2.26 ± 0.345	2.16 ± 0.203	2.33 ± 0.158
8 weeks	3.21 ± 0.312	2.85 ± 0.402	3.90 ± 0.425
12 weeks	2.04 ± 0.283	3.39 ± 0.339*	2.69 ± 0.316
Micronuclei/polychromatic erythrocyte			
4 weeks	1.8 ± 0.31	0.9 ± 0.23	1.6 ± 0.42
8 weeks	1.3 ± 0.16	1.0 ± 0.27	1.0 ± 0.33
12 weeks	0.9 ± 0.30	1.4 ± 0.32	1.6 ± 0.32

* Significantly different ($P \leq 0.05$) from the control group

** $P \leq 0.01$

^a Mean ± standard error; four animals per dose group analyzed for SCE and AGT; eight animals per dose group analyzed for MN

^b Except where noted

^c n=6

^d n=8

^e n=4

^f n=7

APPENDIX G

CHEMICAL CHARACTERIZATION, ANALYSIS, AND GENERATION OF CHAMBER CONCENTRATIONS

PROCUREMENT AND CHARACTERIZATION OF METHYL BROMIDE	176
GENERATION AND MONITORING OF CHAMBER CONCENTRATIONS	176
FIGURE G1 Infrared Spectrum of Methyl Bromide	177
FIGURE G2 Nuclear Magnetic Resonance Spectrum of Methyl Bromide	178
FIGURE G3 Generation System for Methyl Bromide	179
TABLE G1 Analysis of Daily Chamber Concentrations in the 13-Week Inhalation Studies of Methyl Bromide	180
FIGURE G4 Weekly Mean Concentration and Standard Deviation in the 10 ppm Methyl Bromide Mouse Exposure Chamber for the 2-Year Studies	181
FIGURE G5 Weekly Mean Concentration and Standard Deviation in the 33 ppm Methyl Bromide Mouse Exposure Chamber for the 2-Year Studies	182
FIGURE G6 Weekly Mean Concentration and Standard Deviation in the 100 ppm Methyl Bromide Mouse Exposure Chamber for the 2-Year Studies	183

CHEMICAL CHARACTERIZATION, ANALYSIS, AND GENERATION OF CHAMBER CONCENTRATIONS

PROCUREMENT AND CHARACTERIZATION OF METHYL BROMIDE

Methyl bromide (purity grade 99.5%) was obtained in one lot (lot number E21-1012-00) from Matheson Gas Products (Joliet, IL) in five compressed-gas cylinders. Identity, purity, and stability analyses were conducted on representative samples from two cylinders at the analytical chemistry laboratory, Midwest Research Institute (Kansas City, MO). The study material was identified as methyl bromide by infrared (Figure G1) and nuclear magnetic resonance (Figure G2) spectroscopy (Jackman and Sternhell, 1969; Craver, 1977).

Lot number E21-1012-00 was found to be 99.8% pure, as determined by gas chromatography with flame ionization detection using an OPN/Porasil C 80/100 mesh column or a Porapak QS₁ 80/100 mesh column with nitrogen as the carrier gas at 80 or 40 mL/minute, respectively. Each system detected an impurity, with an individual peak area 0.13% or 0.12% of the major peak area. The study laboratory assessed the purity of methyl bromide with a Nicolet 7199 Fourier Transform Infrared Spectrophotometer. One impurity was noted and was identified as methyl chloride. The analysis indicated a methyl bromide purity of 99.1% (w/w).

Periodic analyses of lot E21-1012-00 for purity by gas chromatography indicated no apparent degradation of the study material throughout the studies.

GENERATION AND MONITORING OF CHAMBER CONCENTRATIONS

Vapor Generation System: Methyl bromide was delivered as a neat gas from the cylinder through a shrouded delivery tube to a distribution plenum. Rotameters controlled the gas flow to each chamber (Figure G3).

Vapor Concentration Monitoring: The concentration of methyl bromide in the chambers was determined by a MIRAN 80 infrared spectrophotometer at a wavelength of 3.327 microns. Calibration was carried out with a closed-loop system into which measured volumes of neat methyl bromide were inserted. Air from each chamber was sampled and analyzed for about 10 minutes every hour. Accuracy of the MIRAN 80 data was confirmed by a biweekly simultaneous monitoring with a gas chromatographic determination using an electron capture detector and a Porapak Q column. Generally, data from both methods were within 10% of each other. A summary of the exposure concentrations for the 13-week studies is presented in Table G1, and weekly mean exposure concentrations for the 2-year studies are presented in Figures G4-G6.

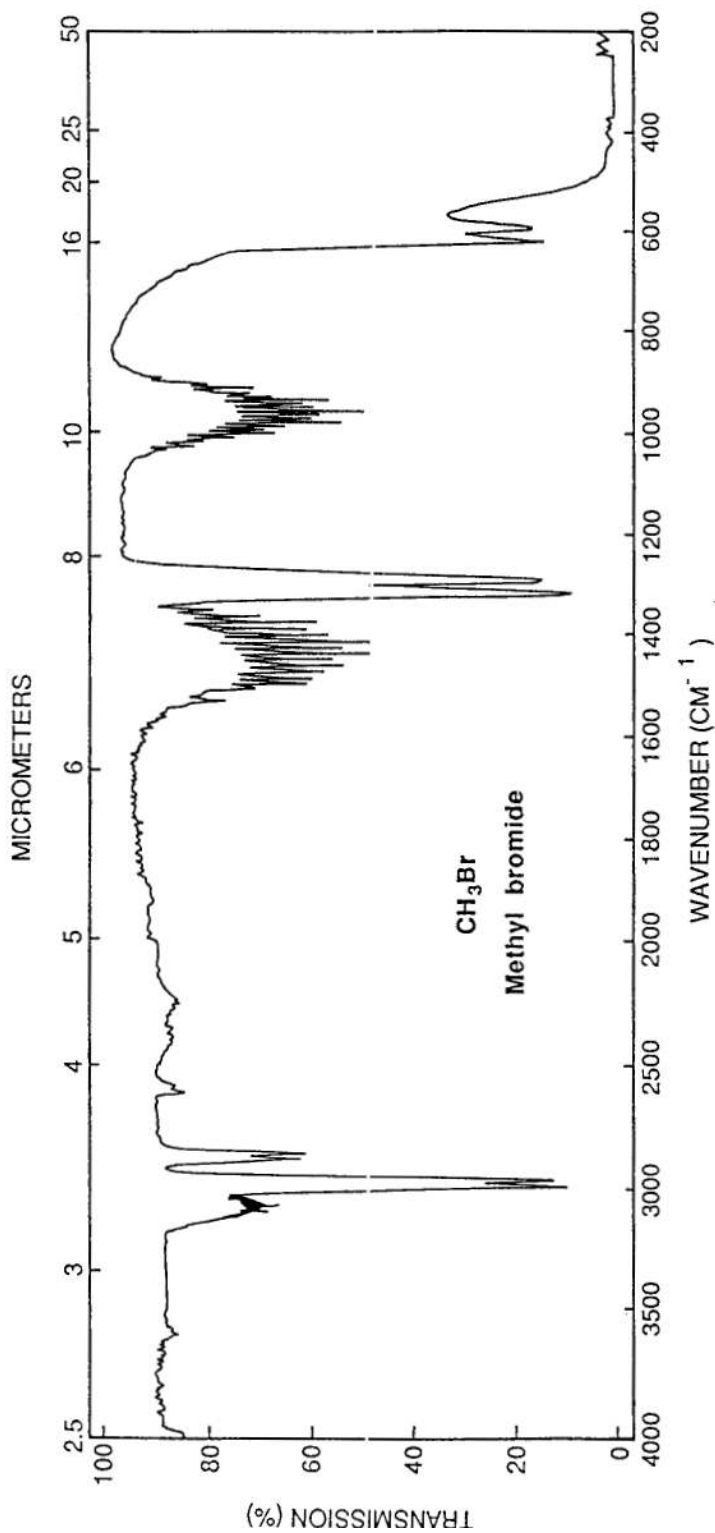

ABSCISSA EXPANSION <u>1</u> SUPPRESSION <u>-</u>	ORDINATE EXPANSION <u>1</u> % T <u>0-100</u> ABS <u>-</u>	SCAN TIME <u>24 min</u> RESPONSE <u>2</u> SLIT PROGRAM <u>6</u>	REP. SCAN <u>-</u> SINGLE BEAM <u>-</u> TIME DRIVE <u>-</u> PRE SAMPLE CHOP <u>-</u> OPERATOR <u>RNB</u> DATE <u>7/14/82</u>
SAMPLE: Methyl bromide Lot No.: M060482 Batch No.: 01	REMARKS <u>Trimmer comb</u> <u>in reference beam</u> <u>Perkin Elmer 283</u>	SOLVENT <u>-</u> CONCENTRATION <u>Neat Gas</u>	CELL PATH <u>86mm (NaCl windows)</u> REFERENCE <u>153N</u>

FIGURE G1
Infrared Spectrum of Methyl Bromide

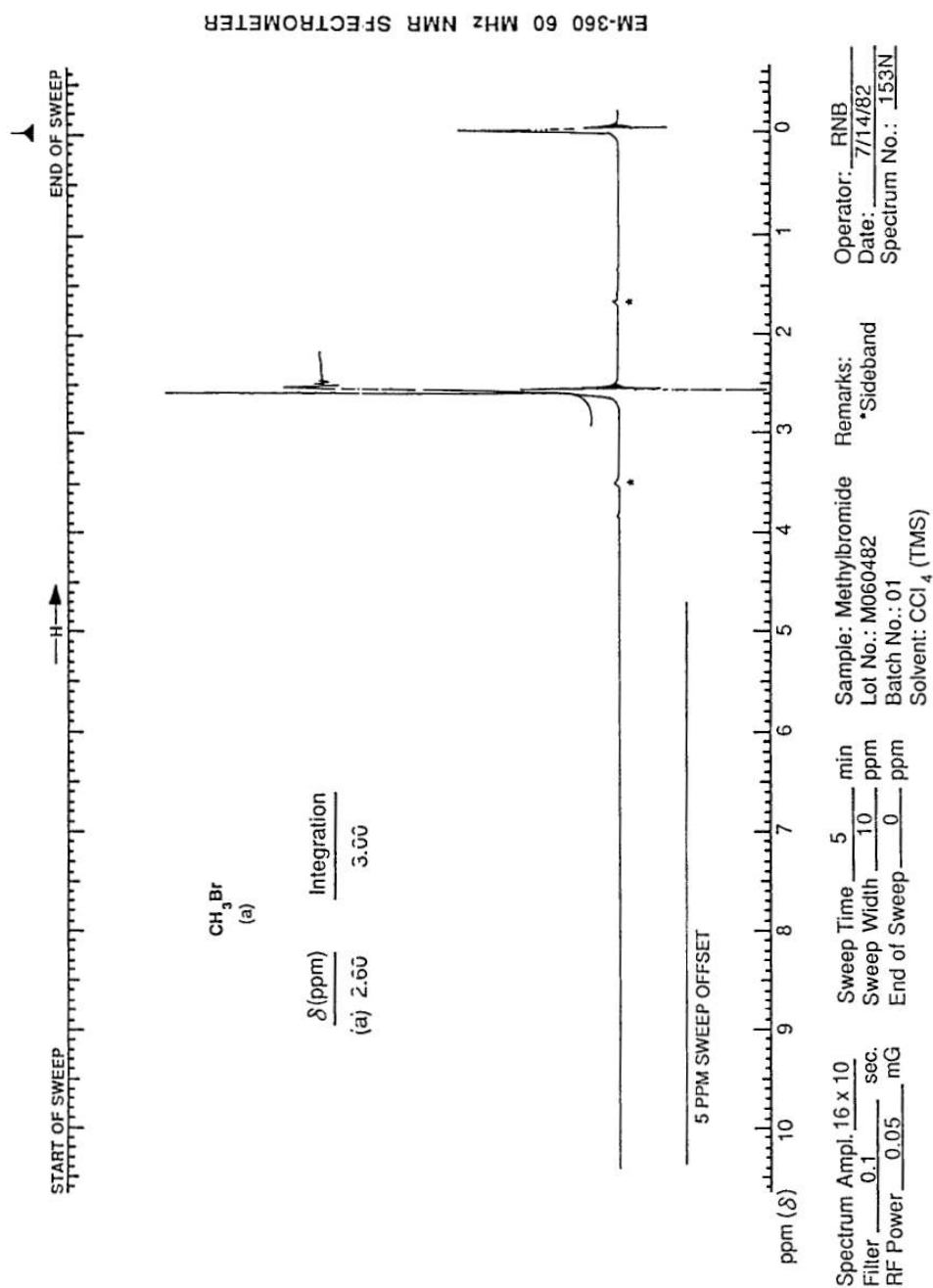

FIGURE G2
Nuclear Magnetic Resonance Spectrum of Methyl Bromide

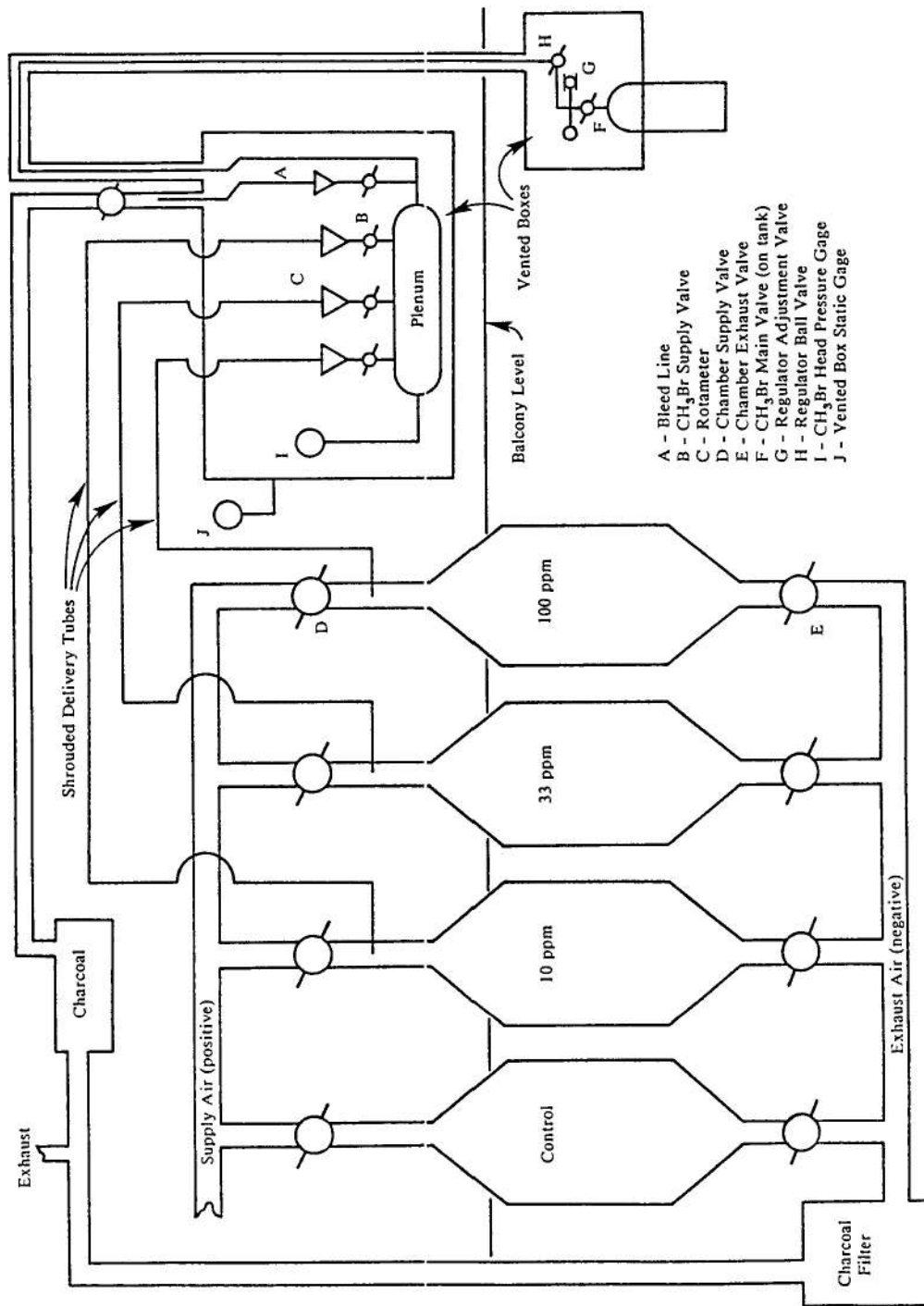

FIGURE G3
 Generation System for Methyl Bromide

TABLE G1
Analysis of Daily Chamber Concentrations in the 13-Week Inhalation Studies of Methyl Bromide

Species	Ranges (%)	Days Concentrations Within Specified Concentration ^a				
		30 ppm	60 ppm	120 ppm		
Rats	>110	0	0	0		
	90-110	61	64	64		
	<90	3	0	0		
	Highest reading	41.2	74.2 ^b	152.2 ^c		
	Lowest reading	24.9	53.9	61.3 ^d		
Mice	>110	22	14	1	0	1
	90-110	41	42	64	66	62
	<90	2	0	0	0	1
	Highest reading	16.7	27.7	48.1	99.6	149.0
	Lowest reading	7.5	14.8	27.9	60.3	71.4 ^e

^a Time weighted average

^b Second highest: 68.1 ppm

^c Second highest: 139.1 ppm

^d Occurred during recalibration of the system; second lowest: 109.4 ppm

^e Second lowest: 95.0 ppm

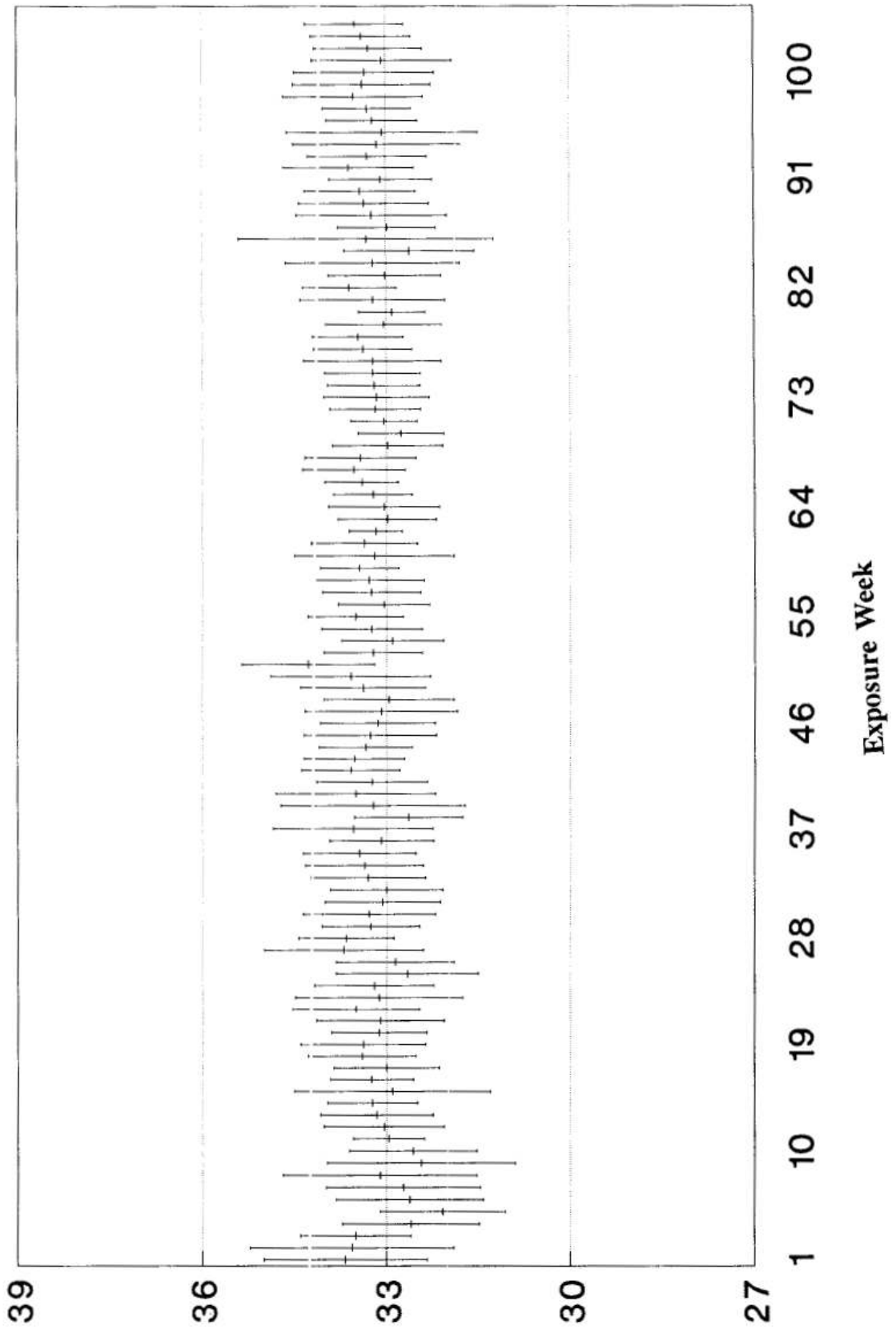

FIGURE G4
Weekly

Mean Concentration and Standard Deviation in the 10 ppm Methyl Bromide Mouse Exposure Chamber for the 2-Year Studies

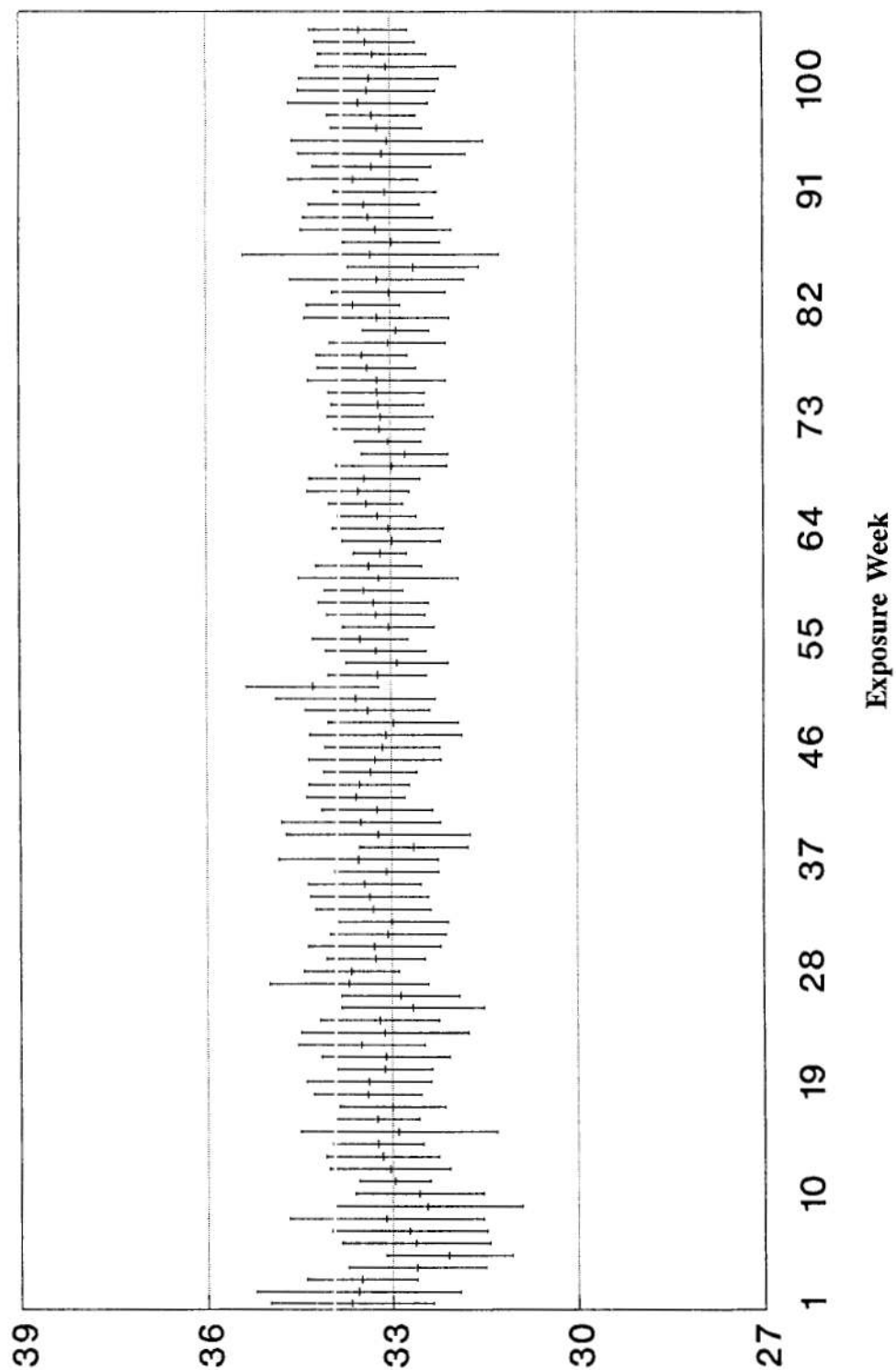

FIGURE G5
Weekly Mean Concentration and Standard Deviation in the 33 ppm Methyl Bromide Mouse Exposure Chamber for the 2-Year Studies

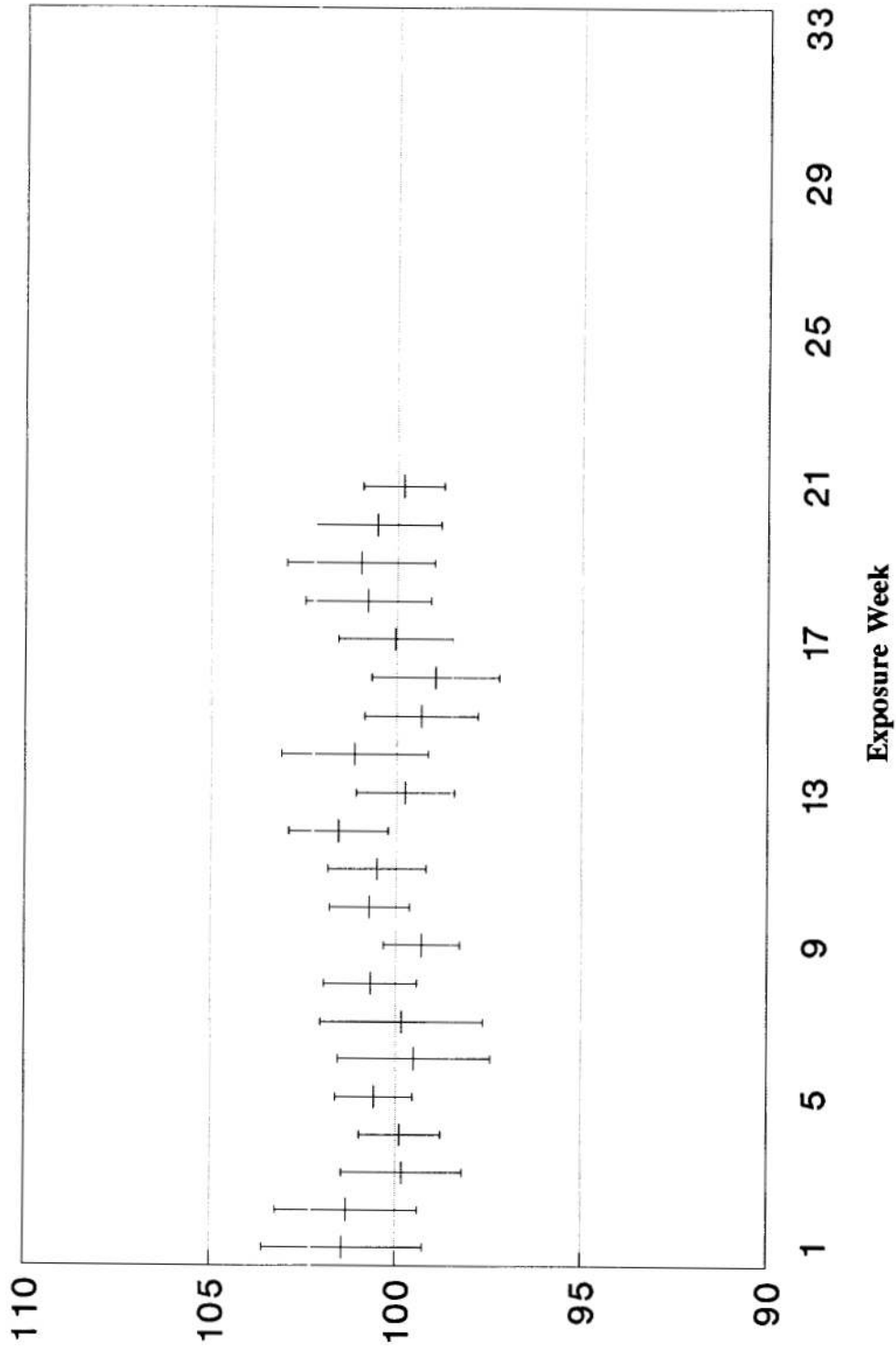

FIGURE G6
Weekly Mean Concentration and Standard Deviation in the 100 ppm Methyl Bromide Mouse Exposure Chamber for the 2-Year Studies

APPENDIX H
INGREDIENTS, NUTRIENT COMPOSITION,
AND CONTAMINANT LEVELS
IN NIH-07 RAT AND MOUSE RATION

TABLE H1	Ingredients of NIH-07 Rat and Mouse Ration	186
TABLE H2	Vitamins and Minerals in NIH-07 Rat and Mouse Ration	186
TABLE H3	Nutrient Composition of NIH-07 Rat and Mouse Ration	187
TABLE H4	Contaminant Levels in NIH-07 Rat and Mouse Ration	188

TABLE H1
Ingredients of NIH-07 Rat and Mouse Ration^a

Ingredients ^b	Percent by Weight
Ground #2 yellow shelled com	24.50
Ground hard winter wheat	23.00
Soybean meal (49% protein)	12.00
Fish meal (60% protein)	10.00
Wheat middlings	10.00
Dried skim milk	5.00
Alfalfa meal (dehydrated, 17% protein)	4.00
Corn gluten meal (60% protein)	3.00
Soy oil	2.50
Dried brewer's yeast	2.00
Dry molasses	1.50
Dicalcium phosphate	1.25
Ground limestone	0.50
Salt	0.50
Premixes (vitamin and mineral)	0.25

^a NCI, 1976; NIH, 1978

^b Ingredients ground to pass through a U.S. Standard Screen No. 16 before being mixed

TABLE H2
Vitamins and Minerals in NIH-07 Rat and Mouse Ration^a

	Amount	Source
Vitamins		
A	5,500,000 IU	Stabilized vitamin A palmitate or acetate
D ₃	4,600,000 IU	D-activated animal sterol
K ₃	2.8 g	Menadione
<i>d</i> - α -Tocopheryl acetate	20,000 IU	
Choline	560.0 g	Choline chloride
Folic acid	2.2 g	
Niacin	30.0 g	
<i>d</i> -Pantothenic acid	18.0 g	<i>d</i> -Calcium pantothenate
Riboflavin	3.4 g	
Thiamine	10.0 g	Thiamine mononitrate
B ₁₂	4,000 μ g	
Pyroxidine	1.7 g	Pyridoxine hydrochloride
Biotin	140.0 mg	<i>d</i> -Biotin
Minerals		
Iron	120.0 g	Iron sulfate
Manganese	60.0 g	Manganous oxide
Zinc	16.0 g	Zinc oxide
Copper	4.0 g	Copper sulfate
Iodine	1.4 g	Calcium iodate
Cobalt	0.4 g	Cobalt carbonate

^a Per ton (2,000 lb) of finished product

TABLE H3
Nutrient Composition of NIH-07 Rat and Mouse Ration

Nutrient	Mean \pm Standard Deviation	Range	Number of Samples
Protein (% by weight)	22.13 \pm 0.49	21.1–23.1	24
Crude fat (% by weight)	5.72 \pm 0.46	4.7–6.5	24
Crude fiber (% by weight)	3.36 \pm 0.23	2.7–3.7	24
Ash (% by weight)	6.43 \pm 0.24	6.1–7.0	24
Amino Acids (% of total diet)			
Arginine	1.320 \pm 0.072	1.310–1.390	5
Cystine	0.319 \pm 0.088	0.218–0.400	5
Glycine	1.146 \pm 0.063	1.060–1.210	5
Histidine	0.571 \pm 0.026	0.531–0.603	5
Isoleucine	0.914 \pm 0.030	0.881–0.944	5
Leucine	1.946 \pm 0.056	1.850–1.990	5
Lysine	1.280 \pm 0.067	1.200–1.370	5
Methionine	0.436 \pm 0.165	0.306–0.699	5
Phenylalanine	0.938 \pm 0.158	0.655–1.050	5
Threonine	0.855 \pm 0.035	0.824–0.898	5
Tryptophan	0.277 \pm 0.221	0.156–0.671	5
Tyrosine	0.618 \pm 0.086	0.564–0.769	5
Valine	1.108 \pm 0.043	1.050–1.170	5
Essential Fatty Acids (% of total diet)			
Linoleic	2.290 \pm 0.313	1.830–2.520	5
Linolenic	0.258 \pm 0.040	0.210–0.308	5
Vitamins			
Vitamin A (IU/kg)	8,825 \pm 2,580	4,700–15,000	24
Vitamin D (IU/kg)	4,450 \pm 1,382	3,000–6,300	4
α -Tocopherol (ppm)	43.58 \pm 6.92	31.1–48.0	5
Thiamine (ppm)	20.38 \pm 1.66	17.0–23.0	24
Riboflavin (ppm)	7.60 \pm 0.85	6.10–8.20	5
Niacin (ppm)	97.80 \pm 31.68	65.0–150.0	5
Pantothenic acid (ppm)	30.06 \pm 4.31	23.0–34.0	5
Pyridoxine (ppm)	7.68 \pm 1.31	5.60–8.80	5
Folic acid (ppm)	2.62 \pm 0.89	1.80–3.70	5
Biotin (ppm)	0.254 \pm 0.053	0.19–0.32	5
Vitamin B ₁₂ (ppb)	24.21 \pm 12.66	10.6–38.0	5
Choline (ppm)	3,122 \pm 416.8	2,400–3,430	5
Minerals			
Calcium (%)	1.13 \pm 0.10	0.95–1.41	24
Phosphorus (%)	0.91 \pm 0.05	0.73–0.99	24
Potassium (%)	0.900 \pm 0.098	0.772–0.971	3
Chloride (%)	0.513 \pm 0.114	0.380–0.635	5
Sodium (%)	0.323 \pm 0.043	0.258–0.371	5
Magnesium (%)	0.167 \pm 0.012	0.151–0.181	5
Sulfur (%)	0.304 \pm 0.064	0.268–0.420	5
Iron (ppm)	410.3 \pm 94.04	262.0–523.0	5
Manganese (ppm)	90.29 \pm 7.15	81.70–99.40	5
Zinc (ppm)	52.78 \pm 4.94	46.10–58.20	5
Copper (ppm)	10.72 \pm 2.76	8.090–15.39	5
Iodine (ppm)	2.95 \pm 1.05	1.52–3.82	4
Chromium (ppm)	1.85 \pm 0.25	1.44–2.09	5
Cobalt (ppm)	0.681 \pm 0.14	0.490–0.780	4

TABLE H4
Contaminant Levels in NIH-07 Rat and Mouse Ration

	Mean \pm Standard Deviation ^a	Range	Number of Samples
Contaminants			
Arsenic (ppm)	0.76 \pm 0.17	0.32–1.07	24
Cadmium (ppm) ^a	<0.10		24
Lead (ppm)	0.50 \pm 0.27	0.05–1.32	24
Mercury (ppm) ^a	<0.05		24
Selenium (ppm)	0.35 \pm 0.09	0.17–0.48	24
Aflatoxins (ppb) ^a	<5.0		24
Nitrate nitrogen (ppm)	14.79 \pm 4.41	2.80–22.0	24
Nitrite nitrogen (ppm)	0.40 \pm 0.73	0.10–2.60	24
BHA (ppm) ^b	2.58 \pm 1.06	2.00–5.00	24
BHT (ppm) ^b	1.83 \pm 1.09	1.00–4.00	24
Aerobic plate count (CFU/g) ^c	33,882 \pm 41,413	770–130,000	24
Coliform (MPN/g) ^d	15.67 \pm 48.48	3.00–240	24
<i>E. coli</i> (MPN/g) ^e	3.00		24
Total nitrosamines (ppb) ^f	7.65 \pm 3.28	3.80–16.00	24
N-Nitrosodimethylamine (ppb) ^f	6.50 \pm 3.09	2.80–15.00	24
N-Nitrosopyrrolidine (ppb) ^f	1.15 \pm 0.30	1.00–3.40	24
Pesticides (ppm)^a			
α -BHC ^g	<0.01		24
β -BHC	<0.02		24
γ -BHC	<0.01		24
δ -BHC	<0.01		24
Heptachlor	<0.01		24
Aldrin	<0.01		24
Heptachlor epoxide	<0.01		24
DDE	<0.01		24
DDD	<0.01		24
DDT	<0.01		24
HCB	<0.01		24
Mirex	<0.01		24
Methoxychlor	<0.05		24
Dieldrin	<0.01		25
Endrin	<0.01		24
Telodrin	<0.01		24
Chlordane	<0.05		24
Toxaphene	<0.1		24
Estimated PCBs	<0.2		24
Ronnel	<0.01		24
Ethion	<0.02		24
Trithion	<0.05		24
Diazinon	<0.1		24
Methyl parathion	<0.02		24
Ethyl parathion	<0.02		24
Malathion ^h	0.10 \pm 0.14	0.05–0.69	24
Endosulfan I	<0.01		24
Endosulfan II	<0.01		24
Endosulfan sulfate	<0.03		24

TABLE H4
Contaminant Levels in NIH-07 Rat and Mouse Ration (continued)

- ^a For values less than the limit of detection, the detection limit is given for the mean.
- ^b Source of contamination: soy oil and fish meal
- ^c CFU = colony forming unit
- ^d MPN = most probable number
- ^e One lot milled 17 October 1984 has a value of 4.0 MPN
- ^f All values were corrected for percent recovery.
- ^g BHC = hexachlorocyclohexane or benzene hexachloride
- ^h Nine lots contained more than 0.05 ppm.

APPENDIX I SENTINEL ANIMAL PROGRAM

METHODS	192
TABLE II Murine Virus Antibody Determinations for Mice in the 2-Year Inhalation Studies of Methyl Bromide	193

SENTINEL ANIMAL PROGRAM

METHODS

Rodents used in the Carcinogenesis Program of the National Toxicology Program are produced in optimally clean facilities to eliminate potential pathogens that may affect study results. The Sentinel Animal Program is part of the periodic monitoring of animal health that occurs during the toxicologic evaluation of chemical compounds. Under this program, the disease state of the rodents is monitored via serology on sera from extra (sentinel) animals in the study rooms. These animals are untreated, and these animals come from the same production source and weaning groups as the animals used for the studies of chemical compounds.

Fifteen B6C3F₁ mice of each sex were selected at the time of randomization and allocation of the animals to the various study groups. Five animals of each designated sentinel group were killed at 6, 12, and 18 months on study. Data from animals surviving 24 months were collected from 5/50 randomly selected chamber control animals of each sex and species. The blood from each animal was collected and clotted, and the serum was separated. The serum was cooled on ice and shipped to Microbiological Associates' Comprehensive Animal Diagnostic Service for determination of antibody titers. The following tests were performed:

<u>Method of Analysis</u>	<u>Time of Analysis</u>
Complement Fixation	
LCM (lymphocytic choriomeningitis virus)	6, 12, 14, 18, 19, and 24 months
ELISA	
PVM (pneumonia virus of mice)	6, 12, 14, 18, 19, and 24 months
Reo 3 (reovirus type 3)	6, 12, 14, 18, 19, and 24 months
GDVII (Theiler's encephalomyelitis virus)	6, 12, 14, 18, 19, and 24 months
MHV (mouse hepatitis virus)	6, 12, 14, 18, 19, and 24 months
M.Ad. (mouse adenovirus)	6, 12, 14, 18, 19, and 24 months
Ectro (infectious ectromelia)	6, 12, 14, 18, 19, and 24 months
Sendai	6, 12, 14, 18, 19, and 24 months
<i>M. pulmonis</i> (<i>Mycoplasma pulmonis</i>)	6, 12, 14, 18, 19, and 24 months
<i>M. arthritidis</i> (<i>Mycoplasma arthritidis</i>)	6, 12, 14, 18, 19, and 24 months
Hemagglutination Inhibition	
Poly (polyoma virus)	6, 12, 14, 18, 19, and 24 months
MVM (minute virus of mice)	6, 12, 14, 18, 19, and 24 months
K (papovavirus)	6, 12, 14, 18, 19, and 24 months
Immunofluorescence Assay	
EDIM (epizootic diarrhea of infant mice)	6, 12, 14, 18, 19, and 24 months

TABLE II
Murine Virus Antibody Determinations for Mice in the 2-Year Inhalation Studies of Methyl Bromide

Interval (months)	Incidence of Antibody in Sentinel Animals	Positive Serologic Reaction for
6	0/10	None
12	1/10	<i>M. arthriditis</i>
14	0/4	None
18	2/9	<i>M. pulmonis</i> ^a
19	1/10	M. Ad.
24	1/5	<i>M. arthriditis</i>

^a Further evaluation of this assay indicated that it was not specific for *M. pulmonis*, and these results were considered to be false positive.

APPENDIX J
SPECIAL 6-WEEK TARGET ORGAN TOXICITY STUDIES

**Toxicology and Pathology of Methyl Bromide in F344 Rats and
B6C3F1 Mice following Repeated Inhalation Exposure**

S. L. Eustis, S. B. Haber, R. T. Drew, and R. S. H. Yang

***Fundamental and Applied Toxicology* 11, 594-610 (1988).**

(Reproduced with permission of Academic Press)

FUNDAMENTAL AND APPLIED TOXICOLOGY **11**, 594-610 (1988)

Toxicology and Pathology of Methyl Bromide in F344 Rats and B6C3F1 Mice following Repeated Inhalation Exposure¹

S. L. EUSTIS,* S. B. HABER,† R. T. DREW,†² AND R. S. H. YANG*

*National Toxicology Program, National Institute of Environmental Health Sciences, P.O. Box 12233, Research Triangle Park, North Carolina 27709, and †Medical Department, Brookhaven National Laboratory, Upton, Long Island, New York 11973

Received October 19, 1987; accepted April 25, 1988

Toxicology and Pathology of Methyl Bromide in F344 Rats and B6C3F1 Mice following Repeated Inhalation Exposure. EUSTIS, S. L., HABER, S. B., DREW, R. T., AND YANG, R. S. H. (1988). *Fundam. Appl. Toxicol* **11**, 594-610. The toxicity of methyl bromide was studied in male and female F344 rats and B6C3F1 mice exposed by inhalation to 160 ppm methyl bromide or air 6 hr/day, 5 days/week for up to 6 weeks. The animals were killed after 3, 10, or 30 exposure days, or when 50% mortality was observed in any group. Only female rats survived the entire 30 exposure days at 160 ppm methyl bromide with less than 50% mortality. There were clear species- and sex-related differences in susceptibility of specific organs to methyl bromide. Primary target organs were the brain, kidney, nasal cavity, heart, adrenal gland, liver, and testis. In rats, neuronal necrosis occurred in the cerebral cortex, hippocampus, and thalamus of the brain whereas in mice neuronal necrosis occurred primarily in the internal granular layer of the cerebellum. Nephrosis occurred in all exposed mice, but not rats, and was likely a major cause of moribundity and death. Necrosis of the olfactory epithelium was more severe and extensive in rats than mice. Myocardial degeneration occurred in male and female rats and to a lesser degree in male mice. There was atrophy of the inner zone of the adrenal cortex in female mice and cytoplasmic vacuolation of the adrenal cortex in rats. Testicular degeneration occurred in rats and mice. The target organ specificity of methyl bromide is similar to that of methyl chloride, suggesting that the two monohalomethanes may have a common mechanism of action. © 1988 Society of Toxicology.

Methyl bromide is widely used as a fumigant. Its popularity as a fumigant is largely attributable to its high toxicity to many pests, the variety of settings in which it can be applied, its ability to penetrate the fumigated substances, and its rapid dissipation following application (Alexeeff and Kilgore, 1983). Methyl bromide is colorless and has little odor at potentially toxic concentrations. Therefore, serious human exposure can occur unknowingly. Even though a warning agent such as

chloropicrin is generally added, the differential vapor pressure between methyl bromide (1420 mm Hg at 20°C) and chloropicrin (18.3 mm Hg at 20°C) makes the effectiveness of this warning agent questionable (Alexeeff and Kilgore, 1983).

Methyl bromide is highly toxic to mammals. Single (0.1 to 32 hr duration) and repeated (7.5 to 8 hr/day, 5 days/week) inhalation exposures, at methyl bromide concentrations ranging from 0.065 to 50 mg/liter (approximately 17 to 13,000 ppm), up to 259 exposures were given to rats, guinea pigs, rabbits, and monkeys (Irish *et al.*, 1940). Rats, guinea pigs, and rabbits succumbed after very few exposures at 220 ppm. While most of the

¹ Presented in part at the 25th Annual Meeting of the Society of Toxicology, March 1986, New Orleans, LA.

² Present address: American Petroleum Institute, 1220 L Street, N.W., Washington, D.C. 20005

rats died without showing significant microscopic lesions, almost all of the guinea pigs showed marked pulmonary damage (congestion, edema, and leucocytic infiltration with frequent hemorrhage into the alveoli). At 100 ppm, there was definite toxicity with some mortality. The guinea pigs appeared to be more resistant than the rats. Rabbits rapidly responded to this concentration, usually developing a paralysis. The one monkey exposed developed convulsions following 11 exposures over a 14-day period. The lung was identified as the primary site of injury. At 66 ppm, rats and guinea pigs showed essentially no response for up to 6 months exposure. Rabbits and monkeys, however, developed paralysis with less than 68 exposures. The paralysis was particularly severe in the rabbits which also had pulmonary lesions. At 33 ppm, rabbits still showed pulmonary damage, whereas the monkeys appeared normal. At 17 ppm, all of the animals survived with no observable toxic response to the exposure.

Danse *et al.* (1984) reported that Wistar rats given 50 mg/kg of methyl bromide in arachis oil by gavage five times a week for 13 weeks developed squamous cell papillomas and carcinomas of the forestomach. This report, however, was disputed by other scientists (Anonymous, 1984). A 13-week stop study using the same experimental design as Danse *et al.* (1984) demonstrated that the proliferative lesions observed after 13 weeks of treatment do regress and should not be considered to be neoplasms (Boorman *et al.*, 1986).

The primary route of exposure of humans to methyl bromide is inhalation. A number of reports (Van Den Oever *et al.*, 1982; Alexeeff and Kilgore, 1983; NIOSH, 1984) provided summaries of the many studies in the literature related to occupational exposures to methyl bromide, including fatal incidences. There are at least 115 known fatalities and 843 known systemic, skin, eye, and other injuries (Alexeeff and Kilgore, 1983). In fatal cases, the most frequently reported lesion included pulmonary edema, congestion, and

hemorrhage. Approximately 105,000 U.S. workers are potentially exposed to methyl bromide (NIOSH, 1984).

The National Toxicology Program (NTP), based upon the original nomination from the California Department of Health Services, initiated a series of studies on the toxicity of methyl bromide. Toxicological studies conducted and/or ongoing in the NTP methyl bromide program include chemical disposition studies (Medinsky *et al.*, 1984, 1985; Bond *et al.*, 1985), 14-day inhalation studies in B6C3F1 mice, 13-week subchronic inhalation studies in F344 rats and B6C3F1 mice, and a 2-year chronic toxicity and carcinogenicity study in B6C3F1 mice. The prechronic studies in rats and mice at exposure concentrations up to 120 ppm indicated that the concentration-response curve with respect to mortality is extremely steep; however, these studies failed to provide a clear-cut indication of target organ effects (Drew *et al.*, 1984; Haber *et al.*, 1985; NTP, unpublished data). Therefore, the present study was carried out to further characterize the target organ toxicity of methyl bromide at near lethal dose in rats and mice; information generated in this study was used in the dose setting and experimental design of the chronic study in mice.

MATERIAL AND METHODS

Animals and animal care. Male and female F344/N rats and B6C3F1 (C57Bl/6N × C3H/HeN MTV-) mice were produced under barrier conditions at the Simonsen Labs, Inc., Gilroy, California, under a contract to the National Toxicology Program. Animals were transferred at 4–5 weeks of age to Brookhaven National Laboratory (BNL) where the inhalation toxicology study was conducted. The rodents were placed on studies at 6–7 weeks of age following quarantine and assessment of the animals health. The health of the animals was verified by a veterinarian and necropsy of five rats and mice each. Each animal was identified with a unique number by toe clipping and a computerized randomization process based on animal body weights was employed for cage and group assignment.

The animals were housed one per stainless-steel hanging wire cage, 10 per cage pack; each species and sex were caged separately. The animals were in the respective in-

596

EUSTIS ET AL.

halation chambers at all times except when the chambers were cleaned, the animals were provided food or weighed, or clinical observations were made. Feed (Ziegler Bros. NIH-07 pelleted diet) was available *ad libitum* during nonexposure hours. Water was available *ad libitum* from an automatic watering system. Animal chambers were maintained at $75 \pm 3^\circ\text{F}$ and 40–70% relative humidity for at least 90% of the time. There were 15 ± 2 changes of room air/hr and fluorescent lighting 12 hr/day.

Test chemical and vapor generation. Methyl bromide was obtained from Matheson Gas Products, Cllet, Illinois (Lot No. EZ1-1012-00). According to the manufacturer, the purity grade was 99.5%. Purity and identity analyses using gas chromatography, infrared and/or nuclear magnetic resonance spectroscopy of the methyl bromide samples were also conducted independently at Midwest Research Institute (MRI) and at BNL and a greater than 99.8% purity was confirmed. Methyl bromide remained stable over the entire experimental period based on the results of the periodical stability analyses.

A cylinder of methyl bromide was enclosed in a vented box and a shrouded deliver tube carried the neat gas to a distribution plenum mounted inside another vented box. The plenum had five ports, three attached to rotameters which controlled the flow to each chamber (only one was used in this study), one as a dampening valve to control plenum pressure, and one as an inlet port. Methyl bromide was metered from the head space of the cylinder through the above distribution system to the intake airstream of the inhalation chamber.

Chamber exposure and monitoring. Animals were exposed via inhalation to either 160 or 0 ppm (control) methyl bromide. Exposures were in 1.4 m³ stainless-steel and glass chambers designed after those described by Hinners *et al.* (1968). The rats and mice were exposed on weekdays only for either 3, 10, or 30 exposure days. Exposure time on each day was T_{90} (time necessary to reach 90% of target concentration; approximately 15 min) plus 6 hr.

The methyl bromide concentration in each chamber was monitored at approximately 40 min intervals using a Miran 80 infrared spectrophotometer. A sampling system drew air (or methyl bromide vapor/air mixture) from each chamber continuously to a manifold very close to the detector. At any given time, one sample was drawn through the detector, while the other sample was being routed through the manifold. The detector switched from chamber to chamber at 10-min intervals, cycling through the two chambers sequentially from the control to the 160 ppm chamber. After sampling the chambers, the system sampled air from the chamber room, and then from the scrubbed exhaust air. As an additional confirmation, the 160 ppm methyl bromide chamber was periodically and simultaneously monitored by gas chromatography. The above chamber analyses

TABLE I
EXPERIMENTAL DESIGN AND TOXICOLOGICAL
ENDPOINTS

Groups	Species	No. of animals (M/F)	
		160 ppm	0 ppm
3 Exposures	Rats ^a	5/5	5/5
10 Exposures	Rats ^a	5/5	5/5
	Mice ^b	5/5	5/5
30 Exposures	Rats ^a	5/5	5/5
	Rats ^b	5/5	5/5
	Mice ^b	15/15	15/15
Total	Rats	20/20	20/20
	Mice	20/20	20/20

^a Endpoints included liver and kidney function assessment, histopathology, and hematology.

^b Endpoints included histopathology and hematology.

^c If mortality within any group reached 50% prior to the scheduled sacrifice, the remaining animals in that particular group were killed at that time.

yielded methyl bromide concentration well within 10% of the target concentration (160 ppm) throughout the study.

Experimental design and toxicological endpoints. Twenty animals/sex/species were exposed to 160 or 0 ppm methyl bromide vapor in each of the two chambers. The anticipated serial deaths, the subgroups, and the toxicological evaluations for each of the subgroups are summarized in Table 1. Toxicological endpoints assessed included clinical observations, mortality, body and organ weights, hematology, clinical chemistry, urinalysis, and gross and histopathology. The analytes of hematology included red and white blood cell counts (RBC, WBC, respectively), hemoglobin (Hgb), hematocrit (HCT), mean corpuscular volume (MCV), mean corpuscular hemoglobin (MCH), and mean corpuscular hemoglobin concentration (MCHC). Those of clinical chemistry included creatinine, sorbitol dehydrogenase (SDH), alanine aminotransferase (ALT), and aspartate aminotransferase (AST or SGOT). Urine was analyzed for volume, specific gravity, protein, glucose, creatinine, and sediment.

All animals were observed twice daily for signs of morbidity or mortality. Body weights were recorded for all animals on the day prior to the first exposure. Animals in the 3 exposure group were weighed again immediately prior to death. All other animals were weighed weekly and immediately prior to death. Animals were killed after the designated exposures or when the number of interim deaths reached 50% of the total in the respective group. A complete necropsy examination was per-

TOXICOLOGY AND PATHOLOGY OF METHYL BROMIDE

597

TABLE 2
SUMMARY OF BODY AND ORGAN WEIGHTS OF B6C3F1 MICE AND F344 RATS FOLLOWING
REPEATED INHALATION EXPOSURE TO 160 ppm METHYL BROMIDE

	Male mice		Female mice	
	Concentration (ppm): 0 n = 20	160 n = 4	0 n = 20	160 n = 10
Body weight (g)	27.3 ± 0.32	20.1 ± 1.48 ^c	20.2 ± 0.25	16.53 ± 0.54 ^c
Lung (g)	0.19 ± 0.00	0.14 ± 0.01 ^c	0.17 ± 0.00	0.12 ± 0.01 ^c
Heart (g)	0.17 ± 0.00	0.13 ± 0.01 ^b	0.12 ± 0.00	0.09 ± 0.00 ^c
Spleen (g)	0.08 ± 0.01	0.05 ± 0.02 ^a	0.08 ± 0.00	0.10 ± 0.01
Right kidney (g)	0.29 ± 0.01	0.24 ± 0.02 ^a	0.19 ± 0.00	0.17 ± 0.01
Thymus (g)	0.05 ± 0.00	0.02 ± 0.00 ^{c*}	0.07 ± 0.01	0.03 ± 0.00 ^c
Brain (g)	0.45 ± 0.01	0.43 ± 0.01 ^a	0.45 ± 0.01	0.42 ± 0.01 ^c
Liver (g)	1.57 ± 0.04	1.18 ± 0.15 ^c	1.22 ± 0.02	0.95 ± 0.05 ^c
Right testes (g)	0.10 ± 0.01	0.10 ± 0.00		
	Male rats		Female rats	
	Concentration (ppm): 0 n = 10	160 n = 5	0 n = 10	160 n = 5
Body weight (g)	164.2 ± 3.0	112.0 ± 10.3 ^c	150.5 ± 3.4	123.6 ± 2.8 ^c
Lung (g)	1.01 ± 0.03	0.73 ± 0.04 ^c	0.87 ± 0.02	0.78 ± 0.03 ^a
Heart (g)	0.66 ± 0.02	0.58 ± 0.02 ^a	0.57 ± 0.01	0.54 ± 0.01
Spleen (g)	0.41 ± 0.01	0.22 ± 0.04 ^c	0.39 ± 0.01	0.38 ± 0.01
Right kidney (g)	0.77 ± 0.02	0.59 ± 0.03 ^c	0.65 ± 0.02	0.55 ± 0.01 ^a
Adrenals (g)	0.05 ± 0.00	0.05 ± 0.01	0.05 ± 0.00	0.06 ± 0.00
Brain (g)	1.66 ± 0.02	1.56 ± 0.02 ^a	1.68 ± 0.02	1.52 ± 0.03 ^c
Liver (g)	6.95 ± 0.19	3.77 ± 0.36 ^c	6.00 ± 0.21	4.65 ± 0.33 ^b
Right testes (g)	1.06 ± 0.03	0.76 ± 0.15 ^a		

Note. All values expressed as $\bar{x} \pm SE$. Male mice killed after 10 exposure days; female mice killed after 8 exposure days. Male rats killed after 14 exposure days; female rats killed after 30 exposure days.

^a 0.01 < $p \leq 0.05$.

^b 0.001 < $p \leq 0.01$.

^c $p \leq 0.001$.

* $n = 3$.

formed. The tissues were fixed in 10% buffered formalin, embedded in paraffin, sectioned at 6 μm , and stained with hematoxylin and eosin. Tissues examined microscopically included adrenal glands, brain, testes, thymus, spleen, heart, liver, kidneys, lung, and nasal cavity.

All variables including body and organ weights, analytes of hematology, kidney and liver function tests, were compared with an analysis of variance (ANOVA) procedure. If body weight appeared as a covariant for the other parameters, an analysis of covariance (ANCOVA) was substituted. When significant differences ($p < 0.05$) were indicated, individual t tests were performed. Bonferroni's correction for multiple t tests was applied.

RESULTS

Mortality, Clinical Observations, and Body and Organ Weights

Higher mortality rates were observed in male and female mice and male rats than in female rats exposed to 160 ppm methyl bromide. The only group that survived the entire 30 exposure days at 160 ppm methyl bromide with less than 50% mortality was the female

598

EUSTIS ET AL.

TABLE 3
SUMMARY OF HEMATOLOGICAL EVALUATION OF B6C3F1 MICE FOLLOWING REPEATED
INHALATION EXPOSURE TO 160 ppm METHYL BROMIDE

Concentration (ppm):	Male mice		Female mice	
	0 (n)	160 (n)	0 (n)	160 (n)
RBC ($10^6/\text{mm}^3$)	8.86 ± 0.19 (19)	8.58 ± 0.18 (3)	10.00 ± 0.07 (20)	6.64 ± 0.26 ^c (10)
WBC ($10^3/\text{mm}^3$)	9.54 ± 0.47 (19)	9.83 ± 2.04 (3)	7.90 ± 0.31 (20)	25.52 ± 5.22 ^c (10)
HgB (g %)	16.72 ± 0.29 (19)	16.57 ± 0.32 (3)	16.42 ± 0.10 (19)	11.30 ± 0.59 ^c (9)
HCT (%)	50.18 ± 0.74 (20)	51.31 ± 0.95 (4)	50.44 ± 0.31 (20)	38.88 ± 2.31 ^c (10)
MCV	56.66 ± 0.55 (19)	60.45 ± 1.83 ^a (3)	50.50 ± 0.43 (20)	58.54 ± 2.72 ^c (10)
MCH	18.91 ± 0.4 (19)	19.30 ± 0.13 (3)	16.45 ± 0.10 (19)	17.12 ± 0.16 ^c (9)
MCHC	33.38 ± 0.6 (19)	31.98 ± 0.80 ^a (3)	32.64 ± 0.19 (19)	29.71 ± 1.19 ^b (9)

Note. All values expressed as $\bar{x} \pm \text{SE}$. Males killed after 10 exposure days; females killed after 8 exposure days.

^a $0.01 < p \leq 0.05$.

^b $0.001 < p \leq 0.01$.

^c $p \leq 0.001$.

rats. Mice were more sensitive than rats and the mortality rate exceeded 50% in the male and female 160 ppm groups after 8 and 6 exposures, respectively. In the male rats exposed to methyl bromide, the mortality rate exceeded 50% after 14 exposure days. According to the original design of the experiment, any group reaching 50% mortality was to be killed. Therefore, the male and female mice and male rats were killed after 10, 8, and 14 exposures, respectively. Logistic problems caused a 4-day (2 exposure days) delay of death of the male mice. At the time of termination, the 160 ppm male mice had only four survivors (20%).

Clinical observations reflecting methyl bromide toxicity in mice included red urine, lethargy, and neurological signs (curling and crossing of the hindlimbs, forelimb twitching and tremors). Similar neurological signs, but to a lesser degree, were observed in the rats exposed to 160 ppm methyl bromide.

Body weight reduction or decreases in body weight gain were seen in the 160 ppm methyl bromide animals. Significant differences between methyl bromide-treated animals and controls were apparent after 5 days of exposure in male and female mice or after 14 exposures in male and female rats. As shown in Table 2, the body weights of the 160 ppm mice and rats were about 18 to 32% lower than those of the corresponding controls at death.

A general trend of organ weight reduction was seen at terminal deaths in both the mice and rats (Table 2). Thus, in mice lung, heart, thymus, brain, and liver weighed significantly less (4 to 60%) than those of the respective controls. Similarly, significant organ weight reduction in rats (6 to 46%) was seen in lung, kidney, spleen, liver, brain, and testes in one or both sexes. Body and organ weight data for the rats on earlier time points (i.e., after 3 and 10 exposure days) were collected; there were

TABLE 4
SUMMARY INCIDENCES OF EXPOSURE-RELATED HISTOPATHOLOGICAL LESIONS IN RATS

	Male rats						Female rats					
	0 ppm		160 ppm		(10)		0 ppm		160 ppm		(10)	
Adrenal gland (No. examined)	(5)	(5)	(10)	(5)	(5)	(10)	(5)	(5)	(10)	(5)	(5)	(10)
Cortex–Cytoplasmic Vacuolation					4	10				5	9	
Brain (No. examined)	(5)	(5)	(10)	(5)	(5)	(10)	(5)	(5)	(10)	(5)	(5)	(10)
Cerebral cortex–Neuronal necrosis						5						10
Cerebral cortex–Gliosis												1
Hippocampus–Neuronal necrosis						1						2
Hippocampus–Gliosis												1
Thalamus–Neuronal necrosis						2						4
Thalamus–Gliosis												1
Cerebellum–Mineralization												2
Testes (No. examined)	(5)	(5)	(10)	(5)	(5)	(10)						
Degeneration	1					3						
Atrophy						2						
Thymus (No. examined)	(5)	(5)	(10)	(5)	(5)	(9)	(5)	(5)	(10)	(5)	(5)	(10)
Necrosis						4						3
Atrophy						5						4
Spleen (No. examined)	(5)	(5)	(10)	(5)	(5)	(10)	(5)	(5)	(10)	(5)	(5)	(10)
Lymphoid depletion						2						4
Hemosiderosis												7
Heart (No. examined)	(5)	(5)	(10)	(5)	(5)	(10)	(5)	(5)	(10)	(5)	(5)	(10)
Degeneration	1	1	7	3	5	10	2	1	9	5	5	10
Liver (No. examined)	(5)	(5)	(10)	(5)	(5)	(10)	(5)	(5)	(10)	(5)	(5)	(10)
Inflammation, subacute focal		2	1			3			2	1	1	6
Necrosis						6						2
Nasal cavity (No. examined)	(5)	(5)	(10)	(5)	(5)	(10)	(5)	(5)	(10)	(5)	(5)	(10)
Olfactory epithelium degeneration				5	3	7				5	5	9
Olfactory epithelium atrophy					5	10					5	10

Note. Male rats were killed after 14 exposure days because the mortality rate exceeded 50%.

TOXICOLOGY AND PATHOLOGY OF METHYL BROMIDE

599

600

EUSTIS ET AL.

TABLE 5
SUMMARY INCIDENCES OF EXPOSURE-RELATED HISTOPATHOLOGICAL LESIONS IN MICE

	Male mice		Female mice	
	0 ppm	160 ppm	0 ppm	160 ppm
Adrenal gland (No. examined)	(20)	(20)	(20)	(18)
x-Zone-Atrophy				16
Brain (No. examined)	(20)	(20)	(20)	(20)
Cerebral cortex-Neuronal necrosis		11		
Cerebellum-Neuronal necrosis		12		10
Hemorrhage		1		
Testes (No. examined)	(20)	(20)		
Atrophy	2	2		
Degeneration	1	15		
Necrosis		1		
Thymus (No. examined)	(20)	(4)	(19)	(7)
Atrophy		4	1	6
Spleen (No. examined)	(20)	(20)	(20)	(20)
Lymphoid depletion	1	17		17
Hematopoiesis	2	7		7
Red pulp cellular depletion				8
Heart (No. examined)	(20)	(20)	(20)	(20)
Degeneration		14		2
Kidney (No. examined)	(20)	(20)	(20)	(20)
Nephrosis		20		19
Lung (No. examined)	(20)	(19)	(20)	(19)
Congestion		4		
Hemorrhage		4		
Thrombi		8	1	5
Nasal cavity (No. examined)	(20)	(20)	(20)	(20)
Olfactory epithelium degeneration		14		1
Olfactory epithelium atrophy		12		

Note. Male mice were killed after 10 exposure days and female mice after 8 exposure days because the mortality rate exceeded 50%.

some indication of reduction of body weight and some organ weights in the methyl bromide-treated rats.

Clinical Laboratory Studies

Changes in hematological analytes were mainly observed in the female mice (Table 3), the most sensitive species and sex. A depression of RBC and related parameters and an elevation of WBC were observed in the female mice. The data on the male mice and the rats, although statistically significant in some instances, were generally unremark-

able. There were no apparent treatment related changes in any of the clinical chemistry and urinalysis analytes measured.

Histopathology of Methyl Bromide Toxicity

Microscopic lesions related to methyl bromide treatment are discussed with respect to individual target organs below. The group incidences of the major histopathologic findings are presented in Tables 4 and 5. Because of the number of early deaths and early termination of all groups of mice, the findings are summarized together.

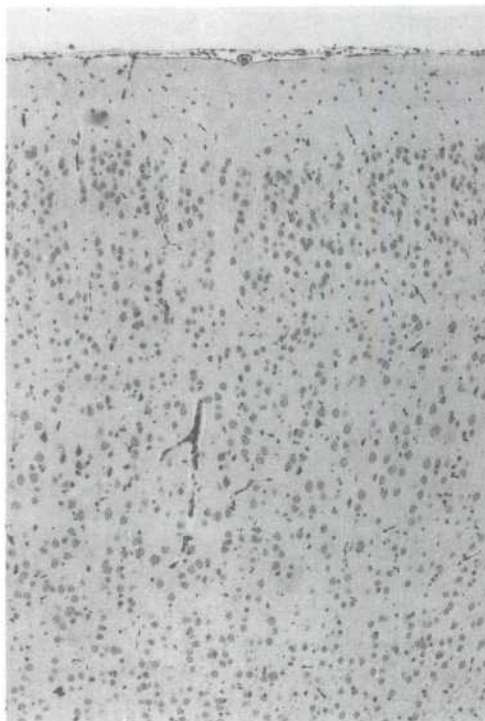

FIG 1 Cerebral cortex from a control male rat. H&E. original magnification X25

Brain. Necrosis and loss of neurons occurred in the cerebral cortex, hippocampus, and thalamus of exposed rats. The lesions were focal, sometimes bilateral, but not symmetrical, and were generally more frequent and severe in female rats than male rats. Minimal lesions primarily involved neurons of the external pyramidal layer. Within the affected areas the neurons had shrunken, pyknotic nuclei and pale eosinophilic cytoplasm and there was rarefaction and vacuolation of the neuropil. In some females there was loss of neurons and proliferation of glial cells (gliosis) (Figs. 1, 2, and 3). The differences between males and females may be related to duration of exposure since the interim deaths and final termination occurred earlier in males than females. Neuronal necrosis in the internal granular layer of the cerebellar folia was frequent in exposed mice (Figs. 4 and 5). This lesion was slightly more

frequent and severe in males than females. Necrosis of pyramidal neurons of the cerebral cortex similar to that in rats also occurred in treated male mice, but it was an extremely subtle change characterized by nuclear pyknosis and occasionally vacuolization of the perikaryon (Fig. 6).

Kidney. Nephrosis, which occurred in all treated mice, was characterized by degeneration, necrosis, and sloughing of the epithelium of convoluted tubules in the renal cortex. There was dilatation of tubules with atrophy of the epithelium, hyaline and granular casts in the tubules, and increased cytoplasmic basophilia indicative of epithelial regeneration (Fig. 7). Because mice died or were terminated after differing numbers of exposures, the extent of involvement by these lesions varied. Minimal nephrosis characterized by focal necrosis and sloughing of tubular epithelium in the renal cortex occurred in a single female rat. This lesion differed from spontaneous nephropathy which was an incidental finding in male and female rats and was characterized by single small clusters of cortical tubules lined by basophilic epithelium (regenerative epithelium).

Testes. Degeneration and atrophy of seminiferous tubules of the testes occurred in several exposed rats. Degeneration included separation and sloughing of spermatocytes and late stage spermatids and/or formation of intratubular multinucleate giant cells. Atrophy was characterized by variable loss of all components of the spermatogenic epithelium. Although degeneration of the testis was diagnosed in one control rat, the lesion was minimal and characterized only by the appearance of a few multinucleated cells.

Degeneration of testes, albeit minimal in severity in many instances, occurred frequently in exposed mice, and mild bilateral atrophy was present in two. One control mouse had severe bilateral atrophy with a relative increase in interstitial Ledge cells, and another control male had unilateral atrophy. Although testicular atrophy in the two control male mice diminishes the potential sig-

602

EUSTIS ET AL.

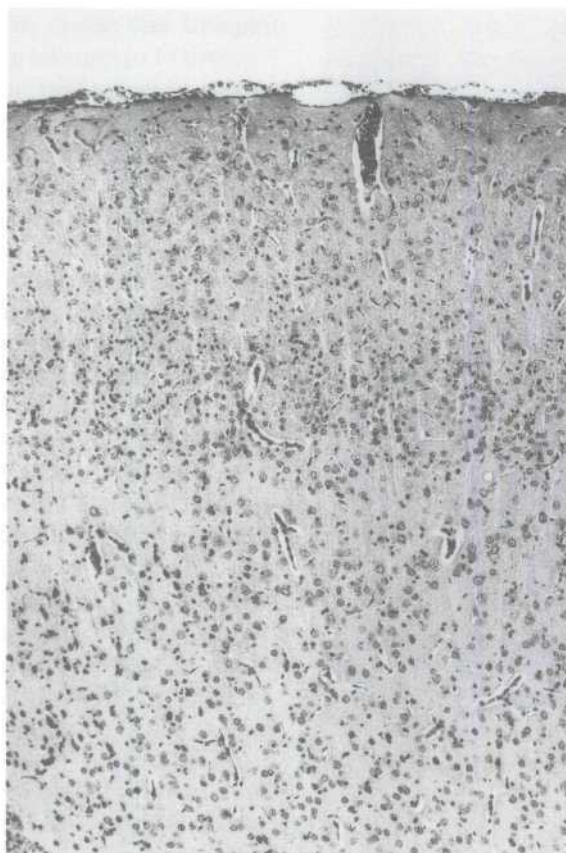

FIG. 2. Cerebral cortex from a male rat exposed to 160 ppm methyl bromide showing shrunken, pyknotic nuclei of cells especially in the external pyramidal layer and the general pallor of the neuropil. Compare with Fig. 1 H&E, original magnification X25.

nificance of this lesion in exposed mice, testicular degeneration is a clear exposure-related effect (Fig. 8).

Nasal cavity. In male and female rats killed after three exposures to methyl bromide, there was moderate to marked degeneration of the olfactory epithelium of the ethmoturbinates and posterior dorsal nasal septum. This was characterized by extensive necrosis and sloughing of olfactory epithelial cells often leaving only a single layer of flattened cells lining the basement membrane. Although there were occasional foci of complete erosion of the olfactory mucosal epithelium, there was no inflammatory response. In rats killed or dying after 10 or

more exposures, actual degeneration of the olfactory epithelium was minimal or mild, but there was focal or multifocal loss of olfactory sensory cells. Foci of atrophy differed from the eroded olfactory epithelium seen more acutely in that a continuous layer of differentiated sustentacular cells remained or in some instances was replaced by ciliated columnar cells (respiratory epithelial metaplasia) (Figs. 9 and 10).

Exposed male mice had varied degrees of degeneration and atrophy of the nasal olfactory epithelium similar to that seen in rats. Because there was no termination after three exposures, the distinction between the more immediate response (degeneration) and later

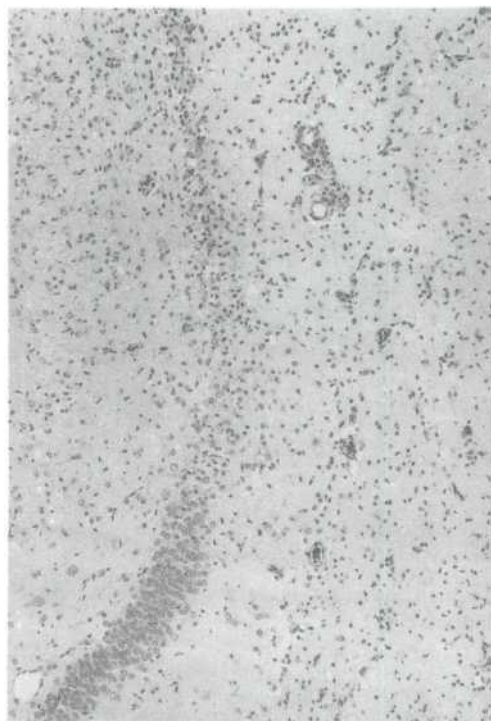

FIG. 3. Hippocampus from a female rat exposed to 160 ppm methyl bromide showing abrupt transition from unaffected neurons of the dentate gyrus to the affected area exhibiting loss of neurons and nuclear pyknosis. There is a locally diffuse increase in microglial cells. H&E, original magnification X25.

response (atrophy) was not as obvious in mice as it was in rats. Minimal degeneration of the olfactory epithelium occurred in only a single female mouse.

Heart. Degeneration of the myocardium occurred more frequently and with greater severity in treated than control male and female rats. The spontaneous myocardial degeneration (cardiomyopathy) that occurs in F344 rats is characterized in young rats by infrequent, small clusters of mononuclear cells and rare myofibers undergoing hyaline degeneration. In rats exposed to methyl bromide, there were increased numbers of mononuclear cells and fusiform nuclei that may represent interstitial cells, foci showing a relative increase in fine reticular fibers, and scattered clear vacuoles (Fig. 11). In mice, de-

generation of the myocardium primarily occurred in treated males and was similar to that in rats but was generally less severe. Minimal degeneration was present in two female mice.

Adrenal gland. Minimal to mild cytoplasmic vacuolation occurred in the adrenal cortex of exposed rats. This consisted of large clear vacuoles in epithelial cells of the zona fasciculata that are presumed to represent lipid droplets. Minimal to marked atrophy of the so called "x-zone" of the adrenal cortex was a frequent finding in female mice (Figs. 12 and 13). The x-zone is a transitory zone surrounding the medulla that regresses at sexual maturity in the male or with the first pregnancy in the female. In methyl bromide-exposed female mice, there was diminished cellularity of the x-zone and the affected cells had less cytoplasm and smaller, more hyperchromatic nuclei than normal cells. Occasional necrotic cells with pyknotic or fragmented nuclei were observed in the x-zone of some females.

Liver. Individual cell necrosis occurred in the liver of several treated rats and generally was more severe in affected males than females. In three treated males and one treated female rat, an inflammatory reaction consisting primarily of macrophages accompanied the hepatocellular necrosis and exceeded the minimal subchronic inflammation noted in other treated and control rats.

Thymus and spleen. Atrophy of the thymus and lymphoid depletion of the spleen occurred in treated rats and mice of both sexes. Thymic atrophy was often severe, and in many mice thymic tissue could not be identified for trimming and embedding.

DISCUSSION

In earlier subchronic studies of methyl bromide in F344 rats and B6C3F1 mice (Drew *et al.*, 1984; Haber *et al.*, 1985; NTP, unpublished data), inhalation exposure to methyl bromide at concentration levels up to 120

604

EUSTIS ET AL.



FIG. 4. Cerebellum of a male mouse exposed to 160 ppm of methyl bromide with focal loss of cellularity in the internal granular cell layer. H&E, original magnification X25.

ppm for 13 weeks at approximately 6 hr/day, 5 days/week resulted in a 17% (4/24) mortality in male mice. No mortality was observed

in female mice and the rats of both sexes. No methyl bromide-induced histological changes were seen in the rats and mice at any

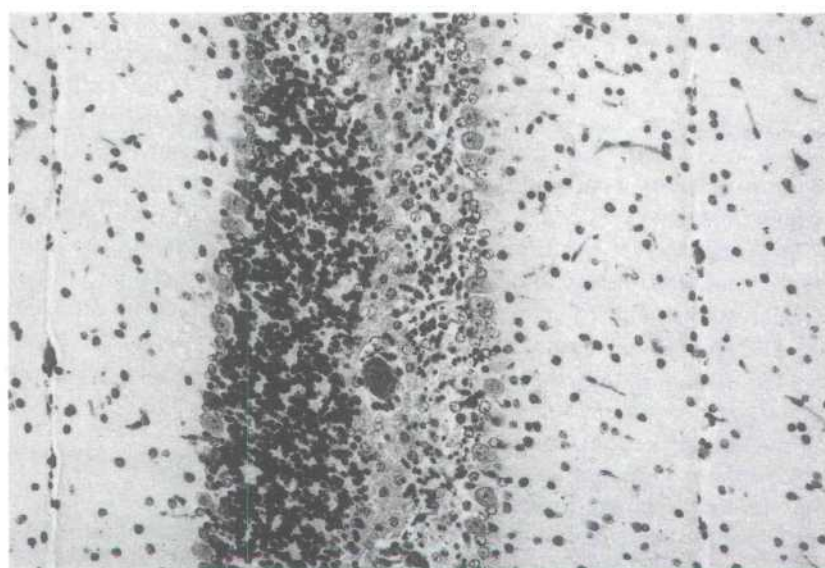

FIG. 5. Higher magnification of the cerebellum shown in Fig. 4. Many of the remaining neurons in the internal granular cell layer are pyknotic. Note the unaffected Purkinje cells. H&E, original magnification X50.

TOXICOLOGY AND PATHOLOGY OF METHYL BROMIDE

605

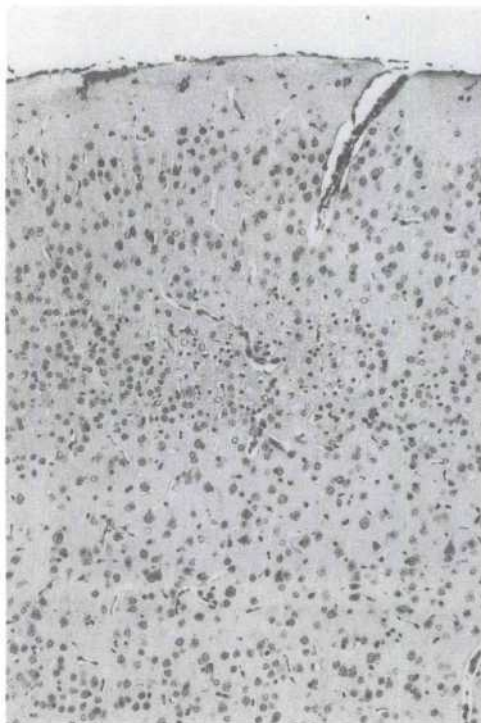

FIG. 6. Cerebral cortex of a male mouse exposed to 160 ppm of methyl bromide with shrunken pyknotic cells in the external pyramidal layer. H&E, original magnification X33.

of the exposure levels including mice killed in a moribund state. In the present study, however, repeated exposure to 160 ppm methyl bromide had profound toxicological effects on mice and rats. High mortality resulted only after a few days exposure to 160 ppm. These findings confirmed our earlier speculation of a very steep concentration-response curve for this chemical.

The most remarkable findings include the clear species and sex differences in sensitivity to methyl bromide toxicity. The mouse was the more susceptible species and females were more susceptible than males. In addition to the differences in mortality, species, and sex-related changes in body and organ weights, differences in hematological analytes and histopathology of certain organs were observed.

Lesions related to exposure to methyl bromide occurred in the kidney, brain, testes, heart, nasal olfactory epithelium, adrenal glands, liver, spleen, and thymus of rats and/or mice. Differences in organ involvement and susceptibility of specific cell types were observed. Nephrosis was likely a major cause of morbidity and death of mice, whereas neuronal necrosis may have been the principal lesion contributing to the early death of some rats. Atrophy of the thymus and lymphoid depletion in the spleen may be related to stress and debilitation rather than a direct toxic effect of methyl bromide.

Our findings generally confirm those of Hurtt *et al.* (1987) who reported similar lesions in male F344 rats exposed to methyl



FIG. 7. Kidney from a female mouse exposed to 160 ppm of methyl bromide. Dilated tubules beneath the capsule are devoid of a lining epithelium, others contain hyaline or granular casts and some are mineralized. Many tubules are lined by regenerating epithelial cells that have large vesicular nuclei and basophilic cytoplasm. H&E, original magnification X25.

606

EUSTIS ET AL.

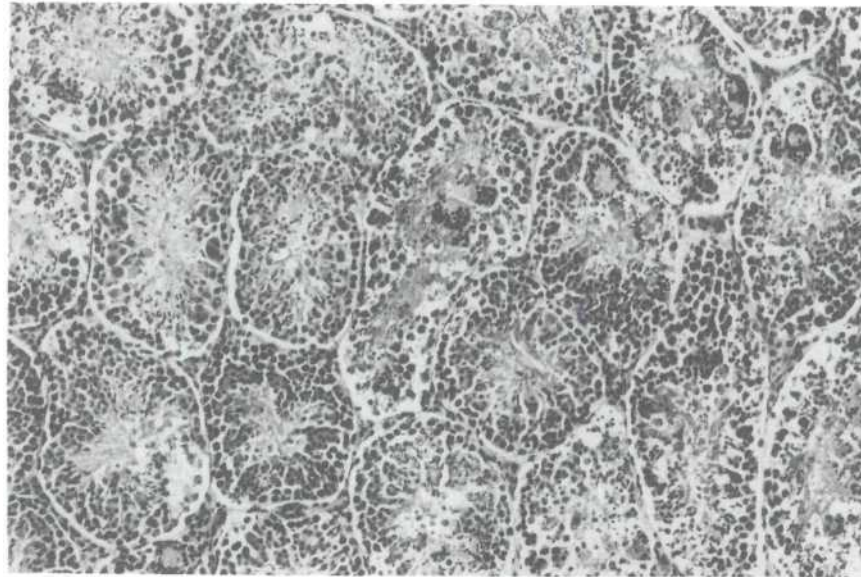

FIG. 8. Testes from a male mouse exposed to 160 ppm of methyl bromide. Note the degeneration of spermatocytes from the germinal epithelium and formation of multinucleated giant cells. H&E, original magnification X25.

bromide at concentrations up to 325 ppm for 6 hr/day for 5 days (female rats were not included in the study). Some important differ-

ences are to be noted, however, and deserve further investigation. Although we identified neuronal necrosis in the cerebral cortex of

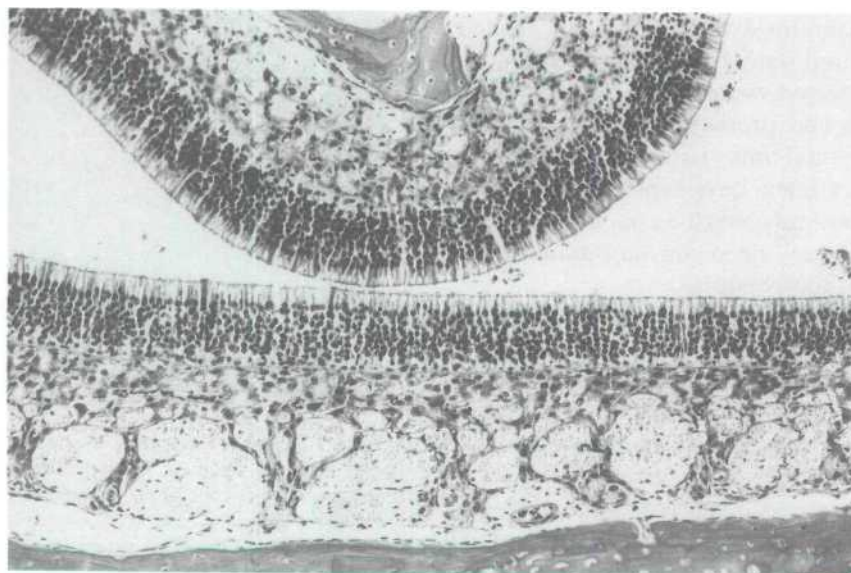

FIG. 9. Olfactory epithelium from a control male rat. H&E, original magnification X50.

TOXICOLOGY AND PATHOLOGY OF METHYL BROMIDE

607

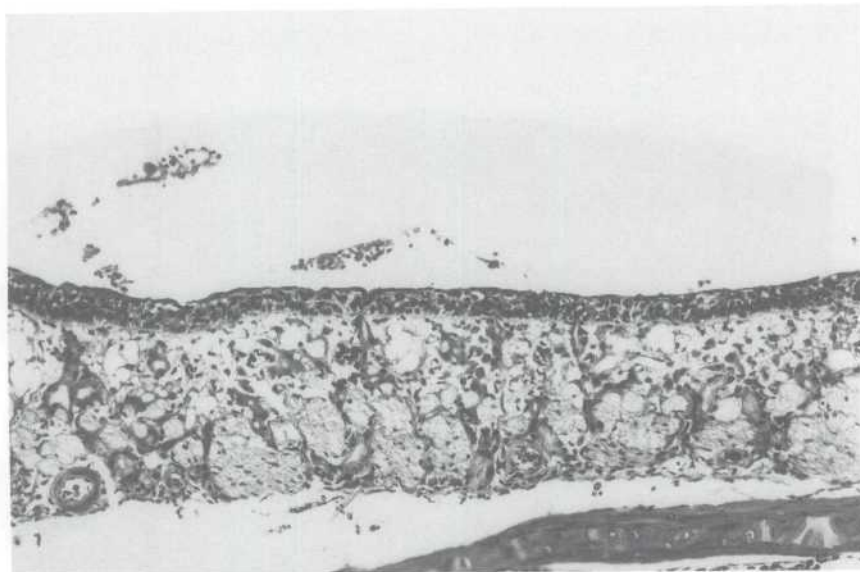

FIG. 10. Olfactory epithelium from a male rat exposed to 160 ppm methyl bromide. Note the reduced thickness of the olfactory epithelium due to loss of differentiated olfactory sensory cells. The remaining epithelial cells are undifferentiated regenerating cells. H&E, original magnification X50.

rats similar to that described by Hurtt *et al.* (1987), we did not see the extensive degeneration of granule cells in the cerebellar cortex of

rats as reported by these authors. This might be explained by the differences in exposure concentrations between their study and ours,

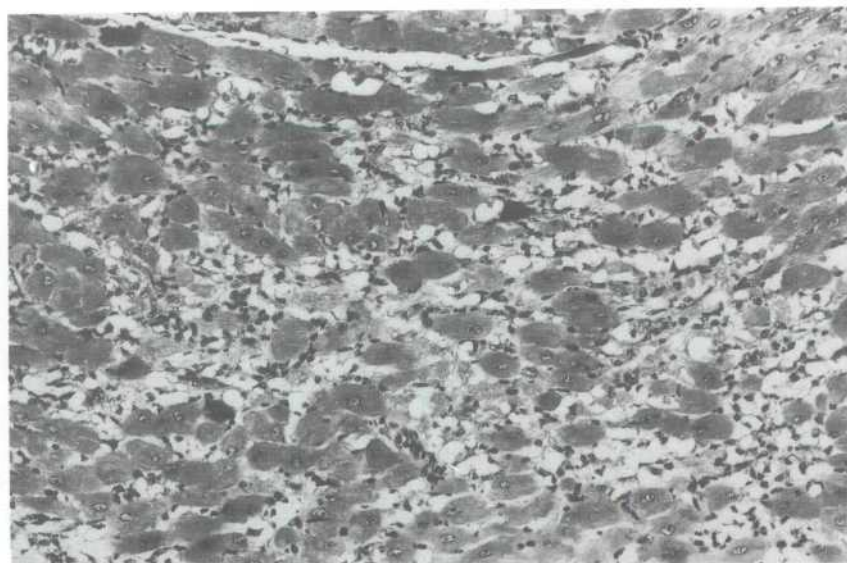

FIG. 11. Myocardium from a male mouse exposed to 160 ppm methyl bromide. Myofibers are separated by interstitial cells with elongated or round nuclei and clear vacuoles. H&E, original magnification X50.

608

EUSTIS ET AL.

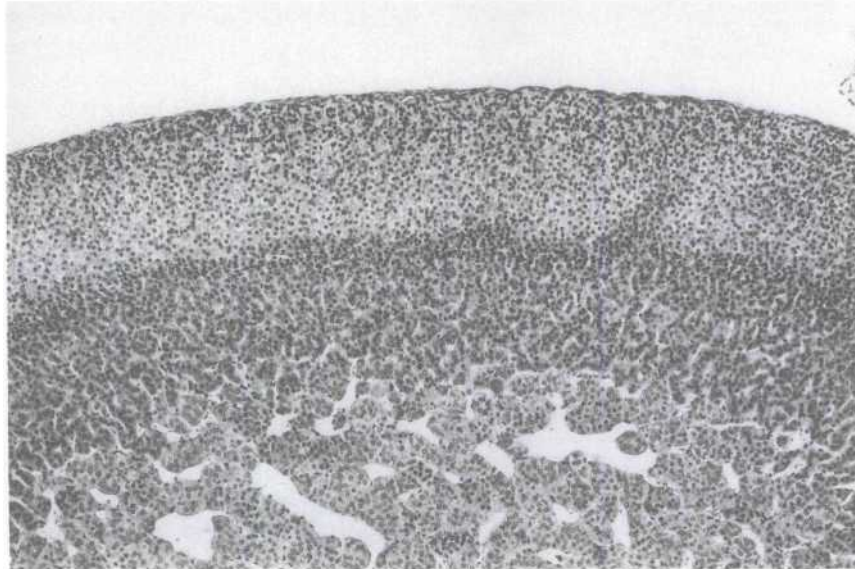

FIG. 12. Adrenal gland from a control female mouse. Note the broad "x-zone" adjacent to the medulla in the inner cortex. H&E, original magnification X25.

since the cerebellar lesion was seen only in rats exposed at levels of 325 and 250 ppm. However, these authors also reported that

cerebellar lesions but not the cerebrocortical lesions were present in rats exposed to 250 ppm methyl bromide, suggesting that the in-

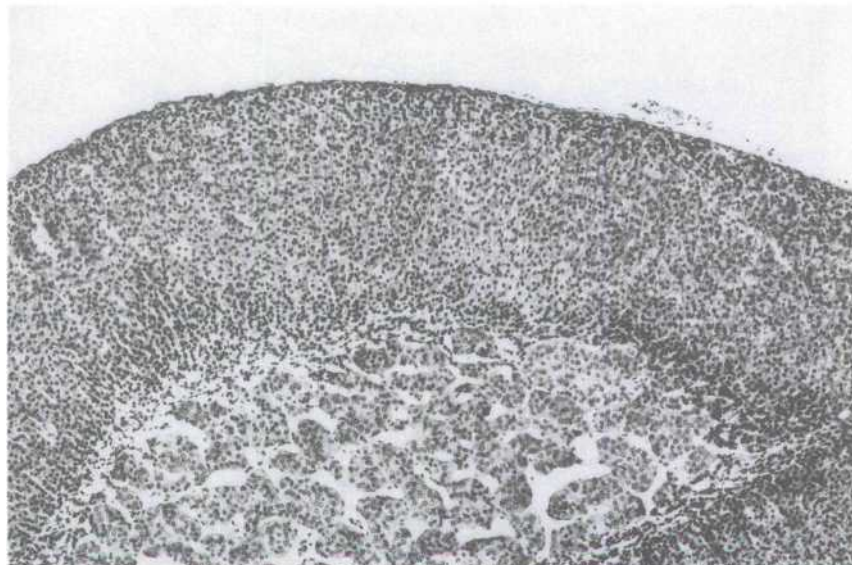

FIG. 13. Adrenal gland from a female mouse exposed to 160 ppm methyl bromide with diminished thickness and atrophy of cells comprising the "x-zone".

TOXICOLOGY AND PATHOLOGY OF METHYL BROMIDE

609

ternal granular cell layer of the cerebellum is more sensitive to the toxic effects of methyl bromide than the cerebral cortex. In contrast we found cerebrocortical lesions but not cerebellar lesions in rats exposed to 160 ppm methyl bromide.

The histopathological lesions occurring in rats and mice are similar in many respects to those seen after inhalation exposure to methyl chloride (Morgan *et al.*, 1982). Cerebellar degeneration characterized by necrosis of neurons in the internal granular cell layer was reported in male and female C57B1/6 mice and to a lesser extent in female B6C3F1 mice exposed to 1000 and/or 2000 ppm of methyl chloride. Lesions in the brains of rats exposed to 5000 ppm of methyl chloride occurred in the internal granular cell layer of the cerebellum similar to that in mice exposed to methyl chloride or methyl bromide. Renal tubular degeneration and necrosis were seen in male and female C3H, C57B1/6, and B6C3F1 mice at 2000 ppm methyl chloride. Moderate to severe renal tubular degeneration and necrosis also occurred in rats exposed to methyl chloride, unlike rats exposed to methyl bromide. Testicular degeneration occurred in male rats exposed to methyl chloride but not in mice. Morgan *et al.* (1982) did not microscopically examine the nasal cavity or heart, so it is unknown if lesions were present at these sites similar to those that occurred in rats and mice exposed to methyl bromide.

It is important to note that clinical and pathological findings in cases of methyl bromide poisoning in man have close similarities with findings in rodents. In addition to the clinical symptoms indicative of neurological, renal, and pulmonary effects in man, autopsies have demonstrated lesions in the cerebral and cerebellar cortices, renal tubular necrosis, and pulmonary edema (Alexeeff and Kilgore, 1983). Pulmonary edema also has been observed in experimental animals at very high concentrations of methyl bromide.

Methyl bromide is readily absorbed from the respiratory tract of the rat, widely distributed in tissues, and rapidly metabolized

(Bond *et al.*, 1985; Medinsky *et al.*, 1985). These authors reported that following a single 6-hr inhalation exposure to 337 nmol of [¹⁴C]methyl bromide/liter air, radioactivity was present in the highest concentrations in lung, adrenal, kidney, liver, and nasal turbinates. In all tissues examined over 90% of the ¹⁴C in the tissues was methyl bromide metabolites. Elimination of ¹⁴C as ¹⁴CO₂ in the exhaled air was the major route of excretion and 47% of the total [¹⁴C]methyl bromide was excreted by this route. Kornbrust and Bus (1982) reported similar findings for the elimination of ¹⁴C following a single inhalation exposure of rats to [¹⁴C]methyl chloride.

Studies from a number of laboratories suggest that methyl halides are metabolized by reaction with glutathione (Johnson, 1966; Barnsley and Young, 1965; Kornbrust and Bus, 1983). In addition, the acute effects of methyl chloride toxicity in male B6C3F1 mice are inhibited by glutathione depletion prior to exposure (Chellman *et al.*, 1986). Kornbrust and Bus (1983) further suggested that the neurotoxic effects and possibly the hepatic and renal toxicity of methyl chloride may be due to the formation of methanethiol in the glutathione metabolic pathway. Similar patterns in the uptake, disposition, metabolism, and excretion of methyl bromide and methyl chloride likely account for many of the similarities of the tissues affected and types of lesions observed.

Studies of methyl bromide and methyl chloride have demonstrated species, strain, sex, and organ differences in susceptibility to the toxic effects of these compounds. Further studies on the pathogenesis of methyl bromide-induced lesions may provide valuable clues for predicting the potential hazard to humans. Two-year studies are currently underway to assess the potential long-term toxicity and carcinogenicity of this compound to B6C3F1 mice.

ACKNOWLEDGMENTS

We thank Dr. Morrow Thompson of National Institute of Environmental Health Sciences for conducting

610

EUSTIS ET AL.

the sorbital dehydrogenase assays; Dr. W. M. Kluwe, formerly of National Institute of Environmental Health Sciences, for the initial discussion on the experimental design; and Drs. D. D. Joel, E. P. Cronkite, L. V. Hankes, Ms. M. O'Connor, Ms. J. Firriolo, Mr. R. Peck, Mr. M. Schmaeler, Mr. P. Bonti, and Mr. R. Tuthill of Brookhaven National Laboratory for their scientific input and technical assistance.

REFERENCES

- ALEXEEFF, G. V. , AND KILGORE, W. W. (1983) Methyl bromide. *Residue Rev.* **88**, 101-153.
- Anonymous (1984). No evidence of methyl bromide carcinogenicity found by NTP panel *Pestic. Toxicol. Chem. News* **13**,9-10
- BARNESLEY E. A. AND YOUNG, L. (1965) Biochemical studies of toxic agents. The metabolism of lodomethane *Biochem J.* **95**, 77-81.
- BOND, J. A. , DUTCHER, J. S. MEDINSKY, M. S. , HENDERSON, R. F. , AND BIRNBAUM, L. S. (1985) Disposition of [¹⁴C]methyl bromide in rats after inhalation *Toxicol. Appl. Pharmacol.* **78**,259-267.
- BOORMAN, G. A. , HONG, H. L., JAMESON, C. W., YOSHITOMI, K., AND MARONPOT, R. R. (1986) Regression of methyl bromide-induced forestomach lesions in the rat. *Toxicol. Appl. Pharmacol.* **86**, 131-139.
- CHELLMAN, G. J. , WHITE, R. D., NORTON, R. M. , AND BUS, J. S. (1986) Inhibition of the acute toxicity of methyl chloride in male B6C3F1 mice by glutathione depletion. *Toxicol. Appl. Pharmacol.* **86**, 93-104.
- DANSE, L. H. J. C., VAN VELSEN, F. L., AND VAN DER HEIJDEN, C. A. (1984) Methyl bromide Carcinogenic effects in the rat forestomach. *Toxicol. Appl. Pharmacol.* **72**, 262-271.
- DREW, R. T., HABER, S. B., AND TICE, R. R. (1984). Sub chronic studies of methyl bromide toxicity in mice. *Toxicologist* **4**, 1 .[Abstract]
- HABER, S. B., DREW, R. T., EUSTIS, S., AND YANG, R. S. H. (1985) Methyl bromide toxicity: A target organ? *Toxicologist* **5**, 130. [Abstract]
- HINNERS, R. G., BURKHART, J. K., AND PUNTE, C. L. (1968) Animal inhalation exposure chambers. *Arch. Environ Health* **16**, 194-206.
- IRISH, D. D., ADAMS, E. M., SPENCER, H. C., AND ROWE, V. K. (1940) The response attending exposure of laboratory animals to vapors of methyl bromide. *J. Ind. Hyg. Toxicol.* **22**, 218-230.
- JOHNSON, M. K. (1966) Studies on glutathione S-alkyl transferase of the rat. *Biochem. J.* **98**, 44-56.
- KORNBRUST, K. J., AND BUS, J. S. (1982) Metabolism of methyl chloride to formate in rats. *Toxicol. Appl. Pharmacol.* **65**, 135-143.
- KORNBRUST, K. J. , AND BUS, J. S. (1983) The role of glutathione and cytochrome P-450 in the metabolism of methyl chloride. *Toxicol. Appl. Pharmacol.* **67**, 246-256.
- MEDINSKY, M. A. , DUTCHER, J. S. , BOND, J. A. , HENDERSON, R. F., MAUDERLY, J. L., SNIPES, M. B., MEWHINNEY, J. A. , CHENG, Y. S. , AND BIRNBAUM, L. S. (1985) Uptake and excretion of [¹⁴C]methyl bromide as influenced by exposure concentration. *Toxicol. Appl. Pharmacol.* **78**, 215-225.
- MORGAN, K. T., SWENBURG, J. A. , HAMM, T. E. , WOLKOWSKI-TYL, R., AND PHELPS, M. (1982) Histopathology of acute toxic response in rats and mice exposed to methyl chloride by inhalation. *Fundam. Appl. Toxicol.* **2**,293-299.
- NIOSH (1984) Monohalomethanes. *Current Intelligence Bulletin* **43**, September 27.
- VAN DEN OEVER, R. , ROOSELS, D., AND LAHAYE, D. (1982) Acute hazard of methyl bromide fumigation in soil disinfection. *Brit. J. Ind. Med.* **39**, 140-144.

**NATIONAL TOXICOLOGY PROGRAM TECHNICAL REPORTS
PRINTED AS OF JANUARY 1992**

TR No.	CHEMICAL	TR No.	CHEMICAL
201	2,3,7,8-Tetrachlorodibenzo- <i>p</i> -dioxin (Dermal)	274	Tris(2-ethylhexyl)phosphate
206	1,2-Dibromo-3-chloropropane	275	2-Chloroethanol
207	Cytembena	276	8-Hydroxyquinoline
208	FD & C Yellow No. 6	277	Tremolite
209	2,3,7,8-Tetrachlorodibenzo- <i>p</i> -dioxin (Gavage)	278	2,6-Xylidine
210	1,2-Dibromoethane	279	Amosite Asbestos
211	C.I. Acid Orange 10	280	Crocidolite Asbestos
212	Di(2-ethylhexyl)adipate	281	HC Red No. 3
213	Butyl Benzyl Phthalate	282	Chlorodibromomethane
214	Caprolactam	284	Diallylphthalate (Rats)
215	Bisphenol A	285	C.I. Basic Red 9 Monohydrochloride
216	11-Aminoundecanoic Acid	287	Dimethyl Hydrogen Phosphite
217	Di(2-ethylhexyl)phthalate	288	1,3-Butadiene
219	2,6-Dichloro- <i>p</i> -phenylenediamine	289	Benzene
220	C.I. Acid Red 14	291	Isophorone
221	Locust Bean Gum	293	HC Blue No. 2
222	C.I. Disperse Yellow 3	294	Chlorinated Trisodium Phosphate
223	Eugenol	295	Chrysotile Asbestos (Rats)
224	Tara Gum	296	Tetrakis(hydroxymethyl) phosphonium Sulfate & Tetrakis(hydroxymethyl) phosphonium Chloride
225	D & C Red No. 9		Dimethyl Morpholinophosphoramidate
226	C.I. Solvent Yellow 14	298	C.I. Disperse Blue 1
227	Gum Arabic	299	3-Chloro-2-methylpropene
228	Vinylidene Chloride	300	<i>o</i> -Phenylphenol
229	Guar Gum	301	4-Vinylcyclohexene
230	Agar	303	Chlorendic Acid
231	Stannous Chloride	304	Chlorinated Paraffins (C ₂₃ , 43% chlorine)
232	Pentachloroethane	305	Dichloromethane (Methylene Chloride)
233	2-Biphenylamine Hydrochloride	306	Ephedrine Sulfate
234	Allyl Isothiocyanate	307	Chlorinated Paraffins (C ₁₂ , 60% chlorine)
235	Zearalenone	308	Decabromodiphenyl Oxide
236	<i>D</i> -Mannitol	309	Marine Diesel Fuel and JP-5 Navy Fuel
237	1,1,1,2-Tetrachloroethane	310	Tetrachloroethylene (Inhalation)
238	Ziram	311	<i>n</i> -Butyl Chloride
239	Bis(2-chloro-1-methylethyl)ether	312	Mirex
240	Propyl Gallate	313	Methyl Methacrylate
242	Diallyl Phthalate (Mice)	314	Oxytetracycline Hydrochloride
243	Trichloroethylene (Rats and Mice)	315	1-Chloro-2-methylpropene
244	Polybrominated Biphenyl Mixture	316	Chlorpheniramine Maleate
245	Melamine	317	Ampicillin Trihydrate
246	Chrysotile Asbestos (Hamsters)	318	1,4-Dichlorobenzene
247	L-Ascorbic Acid	319	Rotenone
248	4,4'-Methylenedianiline Dihydrochloride	320	Bromodichloromethane
249	Amosite Asbestos (Hamsters)	321	Phenylephrine Hydrochloride
250	Benzyl Acetate	322	Dimethyl Methylphosphonate
251	2,4- & 2,6-Toluene Diisocyanate	323	Boric Acid
252	Geranyl Acetate	324	Pentachloronitrobenzene
253	Allyl Isovalerate	325	Ethylene Oxide
254	Dichloromethane (Methylene Chloride)	326	Xylenes (Mixed)
255	1,2-Dichlorobenzene	327	Methyl Carbamate
257	Diglycidyl Resorcinol Ether	328	1,2-Epoxybutane
259	Ethyl Acrylate	329	4-Hexylresorcinol
261	Chlorobenzene	330	Malonaldehyde, Sodium Salt
263	1,2-Dichloropropane	331	2-Mercaptobenzothiazole
266	Monuron	332	<i>N</i> -Phenyl-2-naphthylamine
267	1,2-Propylene Oxide	333	2-Amino-5-nitrophenol
269	Telone II® (1,3-Dichloropropene)	334	C.I. Acid Orange 3
271	HC Blue No. 1	335	Penicillin VK
272	Propylene	336	Nitrofurazone
273	Trichloroethylene (Four Rat Strains)	337	

**NATIONAL TOXICOLOGY PROGRAM TECHNICAL REPORTS
PRINTED AS OF JANUARY 1992**

TR No.	CHEMICAL	TR No.	CHEMICAL
338	Erythromycin Stearate	366	Hydroquinone
339	2-Amino-4-nitrophenol	367	Phenylbutazone
340	Iodinated Glycerol	368	Nalidixic Acid
341	Nitrofurantoin	369	Alpha-Methylbenzyl Alcohol
342	Dichlorvos	370	Benzofuran
343	Benzyl Alcohol	371	Toluene
344	Tetracycline Hydrochloride	372	3,3'-Dimethoxybenzidine Dihydrochloride
345	Roxarsone	373	Succinic Anhydride
346	Chloroethane	374	Glycidol
347	D-Limonene	375	Vinyl Toluene
348	<i>α</i> -Methyldopa Sesquihydrate	376	Allyl Glycidyl Ether
349	Pentachlorophenol	377	<i>o</i> -Chlorobenzalmalonitrile
350	Tribromomethane	378	Benzaldehyde
351	<i>p</i> -Chloroaniline Hydrochloride	379	2-Chloroacetophenone
352	N-Methylolacrylamide	380	Epinephrine Hydrochloride
353	2,4-Dichlorophenol	381	<i>d</i> -Carvone
354	Dimethoxane	382	Furfural
355	Diphenhydramine Hydrochloride	386	Tetranitromethane
356	Furosemide	387	Amphetamine Sulfate
357	Hydrochlorothiazide	389	Sodium Azide
358	Ochratoxin A	390	3,3'-Dimethylbenzidine Dihydrochloride
359	8-Methoxypsoralen	391	Tris(2-chloroethyl) Phosphate
360	N,N-Dimethylaniline	393	Sodium Fluoride
361	Hexachloroethane	395	Probenecid
362	4-Vinyl-1-Cyclohexene Diepoxide	396	Monochloroacetic Acid
363	Bromoethane (Ethyl Bromide)	399	Titanocene Dichloride
364	Rhodamine 6G (C.I. Basic Red 1)	405	C.I. Acid Red 114
365	Pentaerythritol Tetranitrate	415	Polysorbate 80

These NTP Technical Reports are available for sale from the National Technical Information Service, U.S. Department of Commerce, 5285 Port Royal Road, Springfield, VA 22161 (703-487-4650). Single copies of this Technical Report are available without charge (and while supplies last) from the Public Health Service, National Toxicology Program, Central Data Management, P.O. Box 12233, MD A0-01, Research Triangle Park, NC 27709