

**NATIONAL TOXICOLOGY PROGRAM**  
**Technical Report Series**  
**No. 447**



**TOXICOLOGY AND CARCINOGENESIS**

**STUDIES OF ACETONITRILE**

**(CAS NO. 75-05-8)**

**IN F344/N RATS AND B6C3F<sub>1</sub> MICE**

**(INHALATION STUDIES)**

**U.S. DEPARTMENT OF HEALTH AND HUMAN SERVICES**  
**Public Health Service**  
**National Institutes of Health**

## FOREWORD

The National Toxicology Program (NTP) is made up of four charter agencies of the U.S. Department of Health and Human Services (DHHS): the National Cancer Institute (NCI), National Institutes of Health; the National Institute of Environmental Health Sciences (NIEHS), National Institutes of Health; the National Center for Toxicological Research (NCTR), Food and Drug Administration; and the National Institute for Occupational Safety and Health (NIOSH), Centers for Disease Control. In July 1981, the Carcinogenesis Bioassay Testing Program, NCI, was transferred to the NIEHS. The NTP coordinates the relevant programs, staff, and resources from these Public Health Service agencies relating to basic and applied research and to biological assay development and validation.

The NTP develops, evaluates, and disseminates scientific information about potentially toxic and hazardous chemicals. This knowledge is used for protecting the health of the American people and for the primary prevention of disease.

The studies described in this Technical Report were performed under the direction of the NIEHS and were conducted in compliance with NTP laboratory health and safety requirements and must meet or exceed all applicable federal, state, and local health and safety regulations. Animal care and use were in accordance with the Public Health Service Policy on Humane Care and Use of Animals. The prechronic and chronic studies were conducted in compliance with Food and Drug Administration (FDA) Good Laboratory Practice Regulations, and all aspects of the chronic studies were subjected to retrospective quality assurance audits before being presented for public review.

These studies are designed and conducted to characterize and evaluate the toxicologic potential, including carcinogenic activity, of selected chemicals in laboratory animals (usually two species, rats and mice). Chemicals selected for NTP toxicology and carcinogenesis studies are chosen primarily on the bases of human exposure, level of production, and chemical structure. The interpretive conclusions presented in this Technical Report are based only on the results of these NTP studies. Extrapolation of these results to other species and quantitative risk analyses for humans require wider analyses beyond the purview of these studies. Selection *per se* is not an indicator of a chemical's carcinogenic potential.

These NTP Technical Reports are available for sale from the National Technical Information Service, U.S. Department of Commerce, 5285 Port Royal Road, Springfield, VA 22161 (703-487-4650). Single copies of this Technical Report are available without charge while supplies last from NTP Central Data Management, NIEHS, P.O. Box 12233, MD E1-02, Research Triangle Park, NC 27709 (919-541-3419). Listings of all published NTP reports and ongoing studies are also available from NTP Central Data Management. The Abstracts and other study information for 2-year studies are also available on the NTP's World Wide Web site: <http://ntp-server.niehs.nih.gov>.

**NTP TECHNICAL REPORT**  
**ON THE**  
**TOXICOLOGY AND CARCINOGENESIS**  
**STUDIES OF ACETONITRILE**  
**(CAS NO. 75-05-8)**  
**IN F344/N RATS AND B6C3F<sub>1</sub> MICE**  
**(INHALATION STUDIES)**

**NATIONAL TOXICOLOGY PROGRAM**  
**P.O. Box 12233**  
**Research Triangle Park, NC 27709**

**April 1996**

**NTP TR 447**

**NIH Publication No. 96-3363**

**U.S. DEPARTMENT OF HEALTH AND HUMAN SERVICES**  
**Public Health Service**  
**National Institutes of Health**

## CONTRIBUTORS

### National Toxicology Program

*Evaluated and interpreted results and reported findings*

C.J. Alden, Ph.D.  
 G.A. Boorman, D.V.M., Ph.D.  
 D.A. Bridge, B.S.  
 J.R. Bucher, Ph.D.  
 M.R. Elwell, D.V.M., Ph.D.  
 T.J. Goehl, Ph.D.  
 J.K. Haseman, Ph.D.  
 H.A. Herbert, D.V.M., Ph.D.  
 G.N. Rao, D.V.M., Ph.D.  
 J.H. Roycroft, Ph.D.  
 G.S. Travlos, D.V.M.  
 D.B. Walters, Ph.D.  
 K.L. Witt, M.S., Oak Ridge Associated Universities

### Battelle Pacific Northwest Laboratories

*Conducted studies, evaluated pathology findings*

B.J. Chou, D.V.M., Ph.D., Principal Investigator  
 R.A. Miller, D.V.M., Ph.D.  
 H.A. Ragan, D.V.M., Ph.D.  
 S.E. Rowe, D.V.M., M.S.  
 R.B. Westerberg, Ph.D.

### Experimental Pathology Laboratories, Inc.

*Provided pathology quality assurance*

J.F. Hardisty, D.V.M., Principal Investigator  
 E.T. Gaillard, M.S., D.V.M.

### Dynamac Corporation

*Prepared quality assurance audits*

S. Brecher, Ph.D., Principal Investigator

### Analytical Sciences, Inc.

*Provided statistical analyses*

R.W. Morris, M.S., Principal Investigator  
 N.G. Mintz, B.S.  
 S. Rosenblum, M.S.

### NTP Pathology Working Group

*Evaluated slides, prepared pathology report on rats  
 (30 June 1992)*

M.P. Jokinen, D.V.M., Chair  
 Pathology Associates, Inc.  
 J. Cullen, V.M.D., Ph.D.  
 North Carolina State University  
 C. David, D.V.M.  
 North Carolina State University  
 E.T. Gaillard, M.S., D.V.M.  
 Experimental Pathology Laboratories, Inc.  
 J.R. Hailey, D.V.M.  
 National Toxicology Program  
 C.C. Shackelford, D.V.M., M.S., Ph.D.  
 National Toxicology Program  
 R.C. Sills, D.V.M., Ph.D.  
 National Toxicology Program  
 K. Takahashi, D.V.M., M.Sc., Ph.D.  
 National Toxicology Program

*Evaluated slides, prepared pathology report on mice  
 (14 July 1992)*

M.P. Jokinen, D.V.M., Chair  
 Pathology Associates, Inc.  
 D. Dixon, D.V.M., Ph.D.  
 National Toxicology Program  
 E.T. Gaillard, M.S., D.V.M.  
 Experimental Pathology Laboratories, Inc.  
 J.R. Hailey, D.V.M.  
 National Toxicology Program  
 K.T. Morgan, B.V.Sc., Ph.D.  
 Chemical Industry Institute of Toxicology  
 C.C. Shackelford, D.V.M., M.S., Ph.D.  
 National Toxicology Program

### Biotechnical Services, Inc.

*Prepared Technical Report*

D.D. Lambright, Ph.D., Principal Investigator  
 J.R. Beverly, B.A.  
 N.F. Fisher, M.A., M.P.H.  
 G. Gordon, M.A.  
 S.R. Gunnels, M.A.

# CONTENTS

<b>ABSTRACT</b>		<b>5</b>
<b>EXPLANATION OF LEVELS OF EVIDENCE OF CARCINOGENIC ACTIVITY</b>		<b>9</b>
<b>TECHNICAL REPORTS REVIEW SUBCOMMITTEE</b>		<b>10</b>
<b>SUMMARY OF TECHNICAL REPORTS REVIEW SUBCOMMITTEE COMMENTS</b>		<b>11</b>
<b>INTRODUCTION</b>		<b>13</b>
<b>MATERIALS AND METHODS</b>		<b>21</b>
<b>RESULTS</b>		<b>31</b>
<b>DISCUSSION AND CONCLUSIONS</b>		<b>55</b>
<b>REFERENCES</b>		<b>59</b>
<b>APPENDIX A</b>	<b>Summary of Lesions in Male Rats in the 2-Year Inhalation Study of Acetonitrile</b>	<b>65</b>
<b>APPENDIX B</b>	<b>Summary of Lesions in Female Rats in the 2-Year Inhalation Study of Acetonitrile</b>	<b>107</b>
<b>APPENDIX C</b>	<b>Summary of Lesions in Male Mice in the 2-Year Inhalation Study of Acetonitrile</b>	<b>143</b>
<b>APPENDIX D</b>	<b>Summary of Lesions in Female Mice in the 2-Year Inhalation Study of Acetonitrile</b>	<b>177</b>
<b>APPENDIX E</b>	<b>Genetic Toxicology</b>	<b>219</b>
<b>APPENDIX F</b>	<b>Organ Weights and Organ-Weight-to-Body-Weight Ratios</b>	<b>229</b>
<b>APPENDIX G</b>	<b>Hematology and Thyroid Hormone Assay Results</b>	<b>237</b>
<b>APPENDIX H</b>	<b>Chemical Characterization and Generation of Chamber Concentrations</b>	<b>241</b>
<b>APPENDIX I</b>	<b>Ingredients, Nutrient Composition, and Contaminant Levels in NIH-07 Rat and Mouse Ration</b>	<b>259</b>
<b>APPENDIX J</b>	<b>Sentinel Animal Program</b>	<b>265</b>



## ABSTRACT



## ACETONITRILE

CAS No. 75-05-8

Chemical Formula: C<sub>2</sub>H<sub>3</sub>N      Molecular Weight: 41.05

**Synonyms:** Cyanomethane, ethanenitrile, ethyl nitrile, methanecarbonitrile, methyl cyanide, nitrile of acetic acid

Acetonitrile is used primarily as a solvent in extractive distillation and crystallization of pharmaceutical and agricultural products and as a catalyst in chemical reactions. It was nominated for testing by the National Cancer Institute due to its presence in drinking water supplies and the environment, due to lack of information on the carcinogenicity of alkyl cyanides, and because of widespread worker exposure. Male and female F344/N rats and B6C3F<sub>1</sub> mice were exposed to acetonitrile (at least 99% pure) by inhalation for 13 weeks or 2 years. Genetic toxicology studies were conducted in *Salmonella typhimurium*, cultured Chinese hamster ovary cells, and peripheral blood of B6C3F<sub>1</sub> mice exposed to acetonitrile for 13 weeks.

### 13-WEEK STUDY IN RATS

Groups of 10 male and 10 female F344/N rats were exposed to 0, 100, 200, 400, 800, or 1,600 ppm (equivalent to 0, 168, 335, 670, 1,340, or 2,681 mg/m<sup>3</sup>) acetonitrile by inhalation for 6 hours per day, 5 days per week for 13 weeks. Six male and three female rats that received 1,600 ppm and one male that received 800 ppm died during the study. At exposure

concentrations up to and including 800 ppm, the final mean body weights and body weight gains were generally similar to those of the controls. At 1,600 ppm, body weight gain was lower and the final mean body weights of both males and females were significantly lower than those of the controls. Hypoactivity and ruffled fur were observed during the first week of the study in males receiving 800 ppm and males and females receiving 1,600 ppm. Additional clinical findings in 1,600 ppm males that died during week 1 were ataxia, abnormal posture, and clonic convulsions. Clinical pathology findings included nonresponsive, normocytic, normochromic anemia in 1,600 ppm males and females and in 800 ppm females, and decreased triiodothyronine (T<sub>3</sub>) concentrations in 1,600 ppm females. Absolute and relative thymus weights were significantly lower than those of the controls in the 800 and 1,600 ppm males and females. Females exposed to 1,600 ppm had significantly greater absolute and relative heart, kidney, and liver weights than those of the controls. There were no clear exposure-related histopathologic effects, although pulmonary congestion and edema and hemorrhage in the lung and brain were seen in some rats that died early. These lesions are consistent with cyanide-induced anoxia.

### 13-WEEK STUDY IN MICE

Groups of 10 male and 10 female B6C3F<sub>1</sub> mice were exposed to 0, 100, 200, 400, 800, or 1,600 ppm (equivalent to 0, 168, 335, 670, 1,340, or 2,681 mg/m<sup>3</sup>) acetonitrile by inhalation for 6 hours per day, 5 days per week for 13 weeks. All mice exposed to 1,600 ppm died during the first 3 weeks of the study. In addition, one 400 ppm female and one male and four females from the 800 ppm groups also died before the end of the study. Body weight gains were similar to those of controls for all surviving groups of mice except the 800 ppm males, for which the final mean body weight was slightly lower than that of the controls. Clinical findings observed during the first week in 800 and 1,600 ppm mice were hypoactivity and a hunched, rigid posture. In males that received 200 ppm and above, absolute liver weights were greater than that of the controls and relative liver weights were greater in all exposed groups. In 800 ppm females, the absolute liver weight was greater than that of the controls and relative liver weights of females that received 400 ppm and above were greater than that of the controls. Lesions clearly associated with acetonitrile exposure were observed in the stomach, predominantly the forestomach, of males that received 400 ppm and above and of females that received 200 ppm and above. Histologically, these focal or multifocal pale to dark raised lesions consisted of areas of focal epithelial hyperplasia and ulceration, sometimes associated with hemosiderin deposition. An increased incidence of cytoplasmic vacuolation occurred in the liver of males and females exposed to 400 or 800 ppm. A lack of fatty degenerative change was observed in the X-zone of the adrenal cortex of 800 and 1,600 ppm female mice.

### 2-YEAR STUDY IN RATS

The doses selected for the 2-year study of acetonitrile were based on reduced survival of 800 ppm males and 1,600 ppm males and females in the 13-week study. Groups of up to 56 male and 56 female rats were exposed to 0, 100, 200, or 400 ppm (equivalent to 0, 168, 335, or 670 mg/m<sup>3</sup>) acetonitrile by inhalation for 6 hours per day, 5 days per week for 2 years. Eight male and eight female rats from each exposure group were evaluated at 15 months for histopathology and hematology parameters.

### *Survival, Body Weights, Clinical Findings, and Hematology*

Two-year survival, mean body weights, organ weights, behavior, general health, and appearance of exposed male and female rats were similar to those of the controls. The hematologic effects observed were minor and of no biological significance.

### *Pathology Findings*

The incidences of hepatocellular adenoma (3/48), hepatocellular carcinoma (3/48), and hepatocellular adenoma or carcinoma (combined; 5/48) were greater in male rats exposed to 400 ppm than in the controls (one carcinoma). The incidences of hepatocellular adenoma and hepatocellular carcinoma were within the range of historical controls. However, the incidence of hepatocellular adenoma or carcinoma (combined) slightly exceeded the range of historical controls (2%-8%). In addition, the incidences of basophilic, eosinophilic, and mixed cell foci in 400 ppm males were marginally greater than in controls, suggesting hepatotoxicity of acetonitrile. There were no exposure-related liver lesions in female rats.

### 2-YEAR STUDY IN MICE

The exposure concentrations selected for the 2-year study were based on reduced survival and gross and histopathologic lesions in 400, 800, and 1,600 ppm groups of male and female mice in the 13-week study. Groups of 60 male and 60 female mice were exposed to 0, 50, 100, or 200 ppm (equivalent to 0, 84, 168, or 335 mg/m<sup>3</sup>) acetonitrile by inhalation for 6 hours per day, 5 days per week for 2 years. Ten male and 10 female mice from each exposure group were evaluated at 15 months for histopathology.

### *Survival, Body Weights, and Clinical Findings*

Two-year survival of exposed male and female mice was similar to that of the controls, except that the survival of male mice in the 200 ppm group was significantly greater than that of the controls. Mean body weights and organ weights of exposed groups of male and female mice were similar to those of the controls, and no clinical observations in any group were clearly related to acetonitrile exposure.



### ***Pathology Findings***

There were no increases in the incidences of neoplasms that were considered related to acetonitrile exposure in mice. The incidence of squamous hyperplasia of the epithelium of the forestomach was significantly increased at 15 months in 200 ppm females. At 2 years, the increased incidence of this lesion was dose related in all exposed groups of males and females.

### **GENETIC TOXICOLOGY**

Acetonitrile was not mutagenic in *Salmonella typhimurium* strain TA97, TA98, TA100, TA1535, or TA1537, with or without S9 metabolic activation. In cultured Chinese hamster ovary cells, acetonitrile produced a weakly positive response in the sister chromatid exchange test without, but not with, S9. A small increase in chromosomal aberrations was observed in cultured Chinese hamster ovary cells treated with acetonitrile in the presence, but not in the absence, of S9. A significant increase in micronucleated normochromatic erythrocytes was observed

in peripheral blood samples from male mice treated with acetonitrile for 13 weeks; the frequency of micronucleated erythrocytes in female mice was not affected by exposure to acetonitrile.

### **CONCLUSIONS**

Under the conditions of these 2-year inhalation studies, there was *equivocal evidence of carcinogenic activity\** of acetonitrile in male F344/N rats based on marginally increased incidences of hepatocellular adenoma and carcinoma. There was *no evidence of carcinogenic activity* of acetonitrile in female F344/N rats exposed to 100, 200, or 400 ppm. There was *no evidence of carcinogenic activity* of acetonitrile in male or female B6C3F<sub>1</sub> mice exposed to 50, 100, or 200 ppm.

Exposure to acetonitrile by inhalation resulted in increased incidences of hepatic basophilic foci in male rats and of squamous hyperplasia of the forestomach in male and female mice.

---

\* Explanation of Levels of Evidence of Carcinogenic Activity is on page 9. A summary of the Technical Reports Review Subcommittee comments and the public discussion on this Technical Report appears on page 11.

---

**Summary of the 2-Year Carcinogenesis and Genetic Toxicology Studies of Acetonitrile**

---

	Male F344/N Rats	Female F344/N Rats	Male B6C3F <sub>1</sub> Mice	Female B6C3F <sub>1</sub> Mice
<b>Doses</b>	0, 100, 200, or 400 ppm by inhalation (equivalent to 0, 168, 335, or 670 mg/m <sup>3</sup> )	0, 100, 200, or 400 ppm by inhalation (equivalent to 0, 168, 335, or 670 mg/m <sup>3</sup> )	0, 50, 100, or 200 ppm by inhalation (equivalent to 0, 84, 168, or 335 mg/m <sup>3</sup> )	0, 50, 100, or 200 ppm by inhalation (equivalent to 0, 84, 168, or 335 mg/m <sup>3</sup> )
<b>Body weights</b>	Exposed groups similar to controls	Exposed groups similar to controls	Exposed groups similar to controls	Exposed groups similar to controls
<b>2-Year survival rates</b>	11/48, 13/47, 9/48, 17/48	23/48, 21/48, 26/48, 29/48	32/50, 32/50, 32/50, 43/50	28/50, 33/50, 29/50, 32/50
<b>Nonneoplastic effects</b>	<u>Liver</u> : basophilic focus (15/48, 22/47, 25/48, 31/48)	None	<u>Forestomach</u> : squamous hyperplasia (3/49, 3/50, 6/48, 12/50)	<u>Forestomach</u> : squamous hyperplasia (2/49, 7/50, 9/50, 19/48)
<b>Neoplastic effects</b>	None	None	None	None
<b>Uncertain findings</b>	<u>Liver</u> : hepatocellular adenoma (0/48, 1/47, 1/48, 3/48); hepatocellular carcinoma (1/48, 0/47, 0/48, 3/48); hepatocellular adenoma or carcinoma (combined) (1/48, 1/47, 1/48, 5/48)	None	None	None
<b>Level of evidence of carcinogenic activity</b>	Equivocal evidence	No evidence	No evidence	No evidence
<b>Genetic toxicology</b>				
<i>Salmonella typhimurium</i> gene mutations:		Negative with and without S9 in strains TA97, TA98, TA100, TA1535, and TA1537		
Sister chromatid exchanges		Weakly positive without S9; negative with S9		
Cultured Chinese hamster ovary cells <i>in vitro</i> :				
Chromosomal aberrations		Negative without S9; equivocal with S9		
Cultured Chinese hamster ovary cells <i>in vitro</i> :				
Micronucleated erythrocytes		Negative in female mice; positive in male mice		
Mouse peripheral blood <i>in vivo</i> :				

---

## EXPLANATION OF LEVELS OF EVIDENCE OF CARCINOGENIC ACTIVITY

The National Toxicology Program describes the results of individual experiments on a chemical agent and notes the strength of the evidence for conclusions regarding each study. Negative results, in which the study animals do not have a greater incidence of neoplasia than control animals, do not necessarily mean that a chemical is not a carcinogen, inasmuch as the experiments are conducted under a limited set of conditions. Positive results demonstrate that a chemical is carcinogenic for laboratory animals under the conditions of the study and indicate that exposure to the chemical has the potential for hazard to humans. Other organizations, such as the International Agency for Research on Cancer, assign a strength of evidence for conclusions based on an examination of all available evidence, including animal studies such as those conducted by the NTP, epidemiologic studies, and estimates of exposure. Thus, the actual determination of risk to humans from chemicals found to be carcinogenic in laboratory animals requires a wider analysis that extends beyond the purview of these studies.

Five categories of evidence of carcinogenic activity are used in the Technical Report series to summarize the strength of the evidence observed in each experiment: two categories for positive results (**clear evidence** and **some evidence**); one category for uncertain findings (**equivocal evidence**); one category for no observable effects (**no evidence**); and one category for experiments that cannot be evaluated because of major flaws (**inadequate study**). These categories of interpretative conclusions were first adopted in June 1983 and then revised in March 1986 for use in the Technical Report series to incorporate more specifically the concept of actual weight of evidence of carcinogenic activity. For each separate experiment (male rats, female rats, male mice, female mice), one of the following five categories is selected to describe the findings. These categories refer to the strength of the experimental evidence and not to potency or mechanism.

- **Clear evidence** of carcinogenic activity is demonstrated by studies that are interpreted as showing a dose-related (i) increase of malignant neoplasms, (ii) increase of a combination of malignant and benign neoplasms, or (iii) marked increase of benign neoplasms if there is an indication from this or other studies of the ability of such tumors to progress to malignancy.
- **Some evidence** of carcinogenic activity is demonstrated by studies that are interpreted as showing a chemical-related increased incidence of neoplasms (malignant, benign, or combined) in which the strength of the response is less than that required for clear evidence.
- **Equivocal evidence** of carcinogenic activity is demonstrated by studies that are interpreted as showing a marginal increase of neoplasms that may be chemical related.
- **No evidence** of carcinogenic activity is demonstrated by studies that are interpreted as showing no chemical-related increases in malignant or benign neoplasms.
- **Inadequate study** of carcinogenic activity is demonstrated by studies that, because of major qualitative or quantitative limitations, cannot be interpreted as valid for showing either the presence or absence of carcinogenic activity.

When a conclusion statement for a particular experiment is selected, consideration must be given to key factors that would extend the actual boundary of an individual category of evidence. Such consideration should allow for incorporation of scientific experience and current understanding of long-term carcinogenesis studies in laboratory animals, especially for those evaluations that may be on the borderline between two adjacent levels. These considerations should include:

- adequacy of the experimental design and conduct;
- occurrence of common versus uncommon neoplasia;
- progression (or lack thereof) from benign to malignant neoplasia as well as from preneoplastic to neoplastic lesions;
- some benign neoplasms have the capacity to regress but others (of the same morphologic type) progress. At present, it is impossible to identify the difference. Therefore, where progression is known to be a possibility, the most prudent course is to assume that benign neoplasms of those types have the potential to become malignant;
- combining benign and malignant tumor incidence known or thought to represent stages of progression in the same organ or tissue;
- latency in tumor induction;
- multiplicity in site-specific neoplasia;
- metastases;
- supporting information from proliferative lesions (hyperplasia) in the same site of neoplasia or in other experiments (same lesion in another sex or species);
- presence or absence of dose relationships;
- statistical significance of the observed tumor increase;
- concurrent control tumor incidence as well as the historical control rate and variability for a specific neoplasm;
- survival-adjusted analyses and false positive or false negative concerns;
- structure-activity correlations; and
- in some cases, genetic toxicology.

**NATIONAL TOXICOLOGY PROGRAM BOARD OF SCIENTIFIC COUNSELORS  
TECHNICAL REPORTS REVIEW SUBCOMMITTEE**

The members of the Technical Reports Review Subcommittee who evaluated the draft NTP Technical Report on acetonitrile on June 21, 1994, are listed below. Subcommittee members serve as independent scientists, not as representatives of any institution, company, or governmental agency. In this capacity, subcommittee members have five major responsibilities in reviewing NTP studies:

- to ascertain that all relevant literature data have been adequately cited and interpreted,
- to determine if the design and conditions of the NTP studies were appropriate,
- to ensure that the Technical Report presents the experimental results and conclusions fully and clearly,
- to judge the significance of the experimental results by scientific criteria, and
- to assess the evaluation of the evidence of carcinogenic activity and other observed toxic responses.

**Arnold L. Brown, M.D., Chair**  
University of Wisconsin Medical School  
Madison, WI

**Irma Russo, M.D.**  
Fox Chase Cancer Center  
Philadelphia, PA

**Paul T. Bailey, Ph.D.**  
Environmental and Health Sciences Laboratory  
Mobil Oil Corporation  
Princeton, NJ

**Louise Ryan, Ph.D.**  
Division of Biostatistics  
Harvard School of Public Health and  
Dana-Farber Cancer Institute  
Boston, MA

**Meryl H. Karol, Ph.D., Principal Reviewer**  
Department of Environmental Occupational Health  
University of Pittsburgh  
Pittsburgh, PA

**Robert E. Taylor, M.D., Ph.D., Principal Reviewer**  
Department of Pharmacology  
Howard University College of Medicine  
Washington, DC

**Curtis D. Klaassen, Ph.D., Principal Reviewer**  
Department of Pharmacology and Toxicology  
University of Kansas Medical Center  
Kansas City, KS

**Matthew J. van Zwieten, D.V.M., Ph.D.**  
Department of Safety Assessment  
Merck Research Laboratories  
West Point, PA

**Claudia S. Miller, M.D.**  
University of Texas Health Sciences Center  
San Antonio, TX

**Mary Jo Vodick, Ph.D.**  
Lilly MSG Development Center  
Belgium

**Janardan K. Reddy, M.D.**  
Department of Pathology  
Northwestern University Medical School  
Chicago, IL

**Jerrold M. Ward, D.V.M., Ph.D.**  
National Cancer Institute  
Frederick, MD

## SUMMARY OF TECHNICAL REPORTS REVIEW SUBCOMMITTEE COMMENTS

On June 21, 1994, the draft Technical Report on the toxicology and carcinogenesis studies of acetonitrile received public review by the National Toxicology Program's Board of Scientific Counselors' Technical Reports Review Subcommittee. The review meeting was held at the National Institute of Environmental Health Sciences, Research Triangle Park, NC.

Dr. J.R. Bucher, NIEHS, introduced the toxicology and carcinogenesis studies of acetonitrile by discussing the uses of the chemical and rationale for study, describing the experimental design, reporting on survival and body weight effects, and commenting on possible chemical-related neoplastic lesions in male rats and nonneoplastic lesions in male and female mice. The proposed conclusions for the studies were *equivocal evidence of carcinogenic activity* in male F344/N rats, *no evidence of carcinogenic activity* in female F344/N rats, and *no evidence of carcinogenic activity* in male or female B6C3F<sub>1</sub> mice.

Dr. Taylor, a principal reviewer, agreed with the proposed conclusions. He suggested that a sentence be added to the conclusions that in the 2-year studies in male rats there might be some hepatotoxic effects based upon the findings of basophilic, eosinophilic, and mixed cell foci, and Dr. Bucher agreed. Dr. Taylor noted the statement that tobacco smoke contains acetonitrile and wondered if there was literature that could be cited with data quantifying the levels of acetonitrile in cigarette smoke.

Dr. Klaassen, the second principal reviewer, agreed with the proposed conclusions. He thought the highest exposure concentration of acetonitrile in the 2-year studies should have been higher in rats, perhaps 800 ppm.

Dr. Karol, the third principal reviewer, agreed with the proposed conclusions. She concurred with Dr. Klaassen that 800 ppm would have been an appropriate exposure concentration in the 2-year rat studies based on survival in the 13-week studies. Dr. Karol said if gross and histopathological changes observed in rats exposed to 800 ppm were part of the rationale for choosing 400 ppm as the highest exposure concentration for the 2-year studies, a statement should be added. Dr. Bucher disagreed and explained that when setting exposure concentrations based on lethality, the aim is to set the highest exposure concentration slightly greater than a quarter of the lethal dose determined in the 13-week studies unless there is good evidence for a pharmacologic action that is the cause of death. Dr. Karol further commented on the "uncertain" association between acetonitrile exposure and liver neoplasms in male rats that appeared to be based on historical control data showing a 10% incidence of liver neoplasms in feed studies. She said that concurrent controls and the historical data from inhalation studies would be more relevant and likely would support a causal relationship. Dr. Bucher acknowledged that an argument could be made for *some evidence*, but based on the lack of a strong dose-related response, no increase in preneoplastic lesions or atypical foci, and up to four neoplasms in the control groups in some inhalation studies, *equivocal evidence* was considered to be the best conclusion.

Dr. Taylor moved that the Technical Report on acetonitrile be accepted with the revisions discussed and with the conclusions as written for male rats, *equivocal evidence of carcinogenic activity*, and for female rats and male and female mice, *no evidence of carcinogenic activity*. Dr. Klaassen seconded the motion, which was accepted unanimously with 11 votes.



# INTRODUCTION

## CH<sub>3</sub>CN

### ACETONITRILE

CAS No. 75-05-8

Chemical Formula: C<sub>2</sub>H<sub>3</sub>N      Molecular Weight: 41.05

**Synonyms:** Cyanomethane, ethanenitrile, ethyl nitrile, methanecarbonitrile, methyl cyanide, nitrile of acetic acid

#### CHEMICAL AND PHYSICAL PROPERTIES

Acetonitrile is a volatile, clear, colorless liquid with a sweet, ether-like odor, a boiling point of 81.6° C at 760 mm, a density of 0.78745, a vapor pressure of 74.0 mm at 20° C, and a vapor density of 1.42. It is readily miscible with water, acetone, chloroform, carbon tetrachloride, ethanol, ether, ethyl acetate, acetamide solutions, ethylene chloride, methanol, methyl acetate, and many unsaturated hydrocarbons. It is immiscible with many saturated hydrocarbons (petroleum fractions) (*Patty's Industrial Hygiene and Toxicology*, 1982; *Merck Index*, 1989). Acetonitrile produces hydrogen cyanide when heated to decomposition or when reacted with acids or oxidizing agents (Reynolds and Prasad, 1982).

#### PRODUCTION, USE, AND HUMAN EXPOSURE

Acetonitrile is produced as a minor by-product in the commercial synthesis of acrylonitrile by a process involving a high-temperature catalytic reaction between propylene and ammonia. Other production methods involve dehydration of an acetic acid and ammonia mixture, acetamide, or ammonium acetate; the reaction of ethanol and ammonia at moderate temperatures in the presence of a catalyst (e.g., Ag,

Cu, MoO<sub>3</sub> or ZnS); or the reaction of cyanogen chloride with methane, ketones, ethanol, alkylene epoxides, and paraffins or olefins (WHO, 1993).

Acetonitrile is a highly polar solvent with a high dielectric constant and is used primarily to extract fatty acids and animal and vegetable oils (WHO, 1993). It is used for extractive distillation and crystallization of pharmaceutical and agricultural products, such as vitamins, steroids, bactericides, insecticides, plant growth regulators, and fungicides (*Merck Index*, 1976); for separating olefin-diolefin mixtures and C<sub>4</sub>-hydrocarbons in the petrochemical industry; and for isolating components from crude products such as crude wood resin. Due to its superior solvency with polymers, acetonitrile is used as a solvent for spinning fibers and for casting and molding plastics. It is also a component of products used for removing artificial fingernails. It is a common laboratory solvent, and is widely used in high-performance liquid chromatography and as a solvent for DNA synthesis and peptide sequencing (Borman, 1990).

Acetonitrile has been available in commercial amounts in the United States since 1950 (Gergel and Revelise, 1952); United States workers have been potentially exposed to acetonitrile for more than

40 years. The reported annual production of acetonitrile in the United States during 1991 was 10.2 million kg (USITC, 1993), with the extent of potential human exposure in 1991 estimated at greater than 31,000 workers, 25% of whom were female (NIOSH, 1994). The 1991 occupational exposure limit for acetonitrile during an 8-hour shift in the United States was 70 mg/m<sup>3</sup> (40 ppm). Synthesis of acetonitrile is usually carried out in a closed system; therefore, occupational exposure during production could only occur accidentally. However, for many industrial processes, acetonitrile is used in open systems where its high volatility and relatively high air odor threshold influence worker exposure potential. At 25° C, the volatility of acetonitrile will allow concentrations of about 170 ppm in air, and exposure of workers to concentrations in excess of 100 ppm in air is possible (Amoore and Hautala, 1983). In addition, because of the many noncaptive uses of acetonitrile, the general population may also be exposed (NIOSH, 1979).

Smokers have been identified as a group chronically exposed to moderate levels of acetonitrile. Tobacco smoke contains acetonitrile, and its absorption from smoke has been confirmed by urinalysis in 40 smokers and 20 nonsmokers. The average urinary level of acetonitrile was 40 times higher in smokers (117.6 µg/L) than in nonsmokers (2.9 µg/L) (McKee *et al.*, 1962). Estimates of the acetonitrile concentrations in cigarette smoke were not found in the literature. Acetonitrile vapor is also released by the thermal decomposition of flexible polyurethane foams (Woolley, 1972).

## ENVIRONMENTAL IMPACT

Acetonitrile volatilizes from water and soil surfaces (Lyman *et al.*, 1982). It is readily biodegraded by several strains of bacteria common in wastewater sludge, natural waters, and soil; regular exposure of these bacteria to acetonitrile selects strains that are able to degrade these compounds, thus increasing the rate of aerobic degradation. Anaerobic degradation is limited or absent and does not appear to be an effective means of removing the compound from wastewater sludge (Ludzack *et al.*, 1961).

Although the Environmental Survey of Chemicals in Japan reported acetonitrile concentrations between

0.02 and 0.54 mg/kg in 11 out of 60 aquatic sediments sampled in all 47 prefectures, acetonitrile was not detected in 72 water samples (OHS, 1990). To our knowledge, no report was found in the literature showing contamination of food by acetonitrile.

Hydrolysis of acetonitrile in water is extremely slow, and photodegradation is not expected to occur either in the aquatic environment or in air. Volatilization and microbial degradation appear to be the significant factors for removal of acetonitrile from water. The half-life of acetonitrile in natural waters at 20° to 25° C has been estimated based on volatility and biodegradation studies to be approximately 1 to 2 weeks (WHO, 1993).

Acetonitrile has low toxicity to microorganisms (bacteria, cyanobacteria, green algae and protozoans) with thresholds at 520 mg/L or more (Bringmann and Kühn, 1980). The LC<sub>50</sub> for freshwater fish and invertebrates are more than 700 mg/L, with the common carp (*Cyprinus carpio*) being the most sensitive species (48-hour LC<sub>50</sub> of 730 mg/L) (Nishiuchi, 1981).

The major mechanism for removal of acetonitrile from the troposphere is reaction with hydroxyl radicals; reaction with ozone is slow, as is the reaction with singlet oxygen (USEPA, 1985). The atmospheric half-life in air is estimated to be approximately 42 days. However, the hydroxyl reaction rate is 10 times faster than normal in moderately polluted air, which reduces the half-life to less than 20 days. The complete water solubility of acetonitrile suggests that dissolution into clouds and rain droplets may occur, with subsequent removal by rainfall (USEPA, 1985).

Air monitored close to the ground has been shown to contain acetonitrile at concentrations of 3,360 to 11,960 µg/m<sup>3</sup> (2 to 7 ppb by volume), with higher values reported in urban areas than in rural areas; air concentrations of 7.4 ± 2.4 ppb were reported for the city of Wuppertal, Germany. Air samples monitored for acetonitrile in a rural area both before and after burning of bush and grass by farm workers showed a 9-fold increase in acetonitrile concentration from 4.0 to 34.9 ppb. The combustion of wood, straw, and vegetation appears to be the only non-anthropogenic source of atmospheric acetonitrile (Becker and Ionescu, 1982).



## ABSORPTION, DISTRIBUTION, METABOLISM, AND EXCRETION

### *Experimental Animals*

Although no quantitative analytical data are available, acetonitrile is readily absorbed from the lungs and gastrointestinal tract and through the skin, resulting in systemic toxicity. Most of the systemic toxic effects of acetonitrile and other nitriles are mediated through metabolism to cyanide, which is subsequently conjugated with thiosulfate to form thiocyanate and eliminated in the urine (Freeman and Hayes, 1987). Experimental studies with rats, monkeys, and dogs have documented cyanide in the blood and thiocyanate in the urine following exposure to acetonitrile via inhalation or injection (Pozzani *et al.*, 1959a,b). The conversion of acetonitrile to cyanide proceeds at a slower rate than that of other nitriles (Ahmed and Farooqui, 1982). Peak concentrations of blood cyanide were achieved 7.5 hours after acetonitrile dosing and were comparable to blood cyanide levels 1 hour after dosing with similar amounts of other nitriles or potassium cyanide (Freeman and Hayes, 1985a). The percentage of acetonitrile excreted in the urine as thiocyanate was also lower than that for other nitriles, even when the initial dose was higher. These data indicate that the cyanide-dependent toxicity of acetonitrile is less than other nitriles, because it is converted to cyanide more slowly and, consequently, detoxification via thiocyanate excretion is more efficient. Interspecies variations in toxic response are probably related to the relative speed of cyanide formation from acetonitrile; the rapid rate at which cyanide is produced in the mouse appears to account for the high sensitivity of this species to acetonitrile toxicity (Willhite and Smith, 1981).

In pharmacokinetic studies in male rats, free and conjugated hydrogen cyanide, as well as unchanged acetonitrile, were detected in various tissues and organs following intraperitoneal injection or inhalation exposure (Haguenoer *et al.*, 1975a,b). Whole body autoradiography with 2-[<sup>14</sup>C]-acetonitrile in mice demonstrated heavy localization of acetonitrile and its metabolites in the liver, kidney, gastrointestinal tract, gallbladder, and urinary bladder 5 minutes after dosing. At 24 and 48 hours, radioactivity was still retained in the liver and gastrointestinal tract, and delayed accumulation and retention of 2-[<sup>14</sup>C]-acetonitrile was demonstrated in the male reproductive organs and, to a lesser extent, in the brain. The

results of this study suggest that acetonitrile neurotoxicity may be due to the parent acetonitrile molecule rather than to any of its metabolites containing the methyl group, which cannot penetrate the blood-brain barrier (Ahmed *et al.*, 1992). There are no indications that repeated administrations of acetonitrile result in its accumulation in animal tissues.

Elimination of acetonitrile occurs primarily through urinary excretion of the unchanged compound and free and bound hydrogen cyanide. Urinary excretion is greatest during the first 24 hours after dosing, but small amounts were recovered in the urine of rats for up to 4 days following intraperitoneal administration; thiocyanate excretion occurred for up to 11 days (Haguenoer *et al.*, 1975a,b). Pulmonary clearance of unchanged acetonitrile via exhalation is also an important pathway of elimination, especially at high exposure levels.

Biotransformation of acetonitrile to cyanide and thiocyanate have also been demonstrated in a variety of *in vitro* preparations (Ohkawa *et al.*, 1972; Willhite, 1983; Tani and Hashimoto, 1984; Freeman and Hayes, 1987). Acetonitrile is biotransformed via a cytochrome P<sub>450</sub> monooxygenase system to cyanohydrin, which then spontaneously decomposes to hydrogen cyanide and formaldehyde. In a study with liver microsomes isolated from rats pretreated with acetone, an inducer of cytochrome P<sub>450</sub> isozyme 2E1 (Koop and Casazza, 1985), microsomal metabolism of acetonitrile to cyanide was found to be NADPH-dependent and inactivated by heat (Freeman and Hayes, 1985b).

### *Humans*

Acetonitrile is readily absorbed by all routes and rapidly distributed through the body. Exposure can occur via ingestion, inhalation, or absorption through the skin (Fassett, 1963; Losek *et al.*, 1991). Although there is little information on absorption of inhaled acetonitrile in humans, studies on smokers showed that 91% ± 4% of the acetonitrile inhaled in cigarette smoke was retained (Dalhamn *et al.*, 1968a); a significant portion of this could have been retained in the mouth (Dalhamn *et al.*, 1968b). There are no experimental studies of oral or dermal absorption in humans; however, human poisoning cases indicate that acetonitrile is well absorbed by both routes. In a clinical study of 15 cases of accidental acetonitrile poisoning during an industrial exposure that resulted

in one fatality, Amdur (1959) documented the presence of cyanide in the blood, urine, and tissues, and of thiocyanate in the serum. In a case of suicidal oral acetonitrile ingestion, elimination half-lives of 32 hours for acetonitrile and 15 hours for cyanide were calculated during the hospitalization of the patient prior to death (Michaelis *et al.*, 1991).

## TOXICITY

### *Experimental Animals*

Acetonitrile toxicity has been demonstrated in animals following administration by inhalation, injection, gavage, or dermal application. The LD<sub>50</sub> values for acetonitrile vary widely (175 to 5,620 mg/kg body weight) depending on the species and route of administration (Smyth and Carpenter, 1948; Pozzani *et al.*, 1959a,b; Kimura *et al.*, 1971). The LC<sub>50</sub> values in acute inhalation studies with acetonitrile range from approximately 2,700 ppm for a 1-hour inhalation exposure or 2,300 ppm for a 2-hour inhalation exposure in mice to 16,000 ppm for a 4-hour inhalation exposure or 12,000 ppm for an 8-hour inhalation exposure in rats. Mice appear to be the species most sensitive to exposure to acetonitrile by inhalation. The lowest published LC<sub>50</sub> for a single, 4-hour inhalation exposure in rats is 8,000 ppm (Smyth and Carpenter, 1948). The LD<sub>50</sub> values for dermal applications in rabbits (1.25 mL/kg undiluted acetonitrile) are similar to or lower than those obtained after oral administration in other animal species.

Signs and symptoms of acute acetonitrile intoxication are similar in different animal species and indistinguishable from those observed after exposure to cyanide or other nitriles (Willhite, 1981; Willhite and Smith, 1981). Animals exposed to acetonitrile via different routes of administration always exhibit respiratory symptoms, often followed by prostration and seizures. Rapid and irregular respiration occurred 1 to 3 hours after a subcutaneous injection in rabbits, followed by immobilization, convulsions, and the death of two out of seven animals (Verbrugge, 1899). Rats exposed to 2,800 ppm acetonitrile by inhalation for 2 hours per day for 5 days had difficulty breathing, impaired renal function, and paralysis of the extremities (Haguenoer *et al.*, 1975b). CD-1 mice exposed to concentrations of 500 to 5,000 ppm by inhalation displayed dyspnea, tachypnea, gasping, tremors, convulsions, and corneal

opacity within 30 to 300 minutes; the LC<sub>50</sub> for a 60-minute exposure was 2,693 ppm. All mice exposed to 5,000 ppm for 60 minutes died within 2 hours (Willhite, 1981). In an inhalation study in four Rhesus monkeys, one monkey exposed to 2,510 ppm acetonitrile appeared normal after the first day of inhalation, but showed poor coordination followed by prostration and labored breathing during the second day; death occurred a few hours later. Two monkeys exposed to 660 ppm appeared uncoordinated from the second week; one monkey died on day 23 and the other on day 51. The last monkey was exposed to 330 ppm and showed overextension reflexes and hyperexcitability toward the end of the 99-day inhalation period (Pozzani *et al.*, 1959a).

In rats exposed to 1,038, 3,104, or 10,485 mg/m<sup>3</sup> acetonitrile vapor 6 hours per day, 5 days per week for 1 month, lower body weight and death were observed at the highest exposure level, and respiratory and/or ocular irritation occurred at 3,104 and 10,485 mg/m<sup>3</sup> (Roloff *et al.*, 1985). Exposure of F344 male rats and B6C3F<sub>1</sub> mice to 100, 200, or 400 ppm acetonitrile by inhalation for 13 weeks had no effect on body weight, testicular weight, or sperm motility (Morrissey *et al.*, 1988).

Histopathologic examination of rat lungs after acetonitrile inhalation exposure showed hemorrhage and congestion (Haguenoer *et al.*, 1975b). In a 90-day inhalation study in which rats were exposed to acetonitrile concentrations of 166, 330, or 665 ppm for 7 hours per day, 5 days per week, lesions observed at 665 ppm were cloudy swelling of the kidney and liver and alveolar capillary congestion and/or focal edema with or without bronchial inflammation in the lung (Pozzani *et al.*, 1959a). Also observed in this study were sporadic, focal hemorrhagic lesions in the brain that were characteristic of anoxia. In another inhalation study, CD-1 rats were exposed to 3,000 ppm acetonitrile for 4 hours and had markedly increased serum enzymes (glutamic oxaloacetic transaminase, glutamic pyruvic transaminase, and ornithine carbamyl transferase), indicating acute hepatic injury (Drew *et al.*, 1978). Three monkeys were exposed to 350 ppm acetonitrile by inhalation 7 hours per day, 5 days per week for 91 days. Hemorrhages of the superior and inferior sagittal sinuses were found at necropsy in all three monkeys (Pozzani *et al.*, 1959a).

### **Humans**

The levels causing toxicity in humans are unknown, but are probably in excess of 840 mg/m<sup>3</sup> (500 ppm) in air. In an inhalation study in three human volunteers, exposure to 40 ppm of acetonitrile for 4 hours produced no adverse effects during the exposure period, although one subject reported a slight tightness of the chest a few hours later. All three subjects detected the odor of acetonitrile for the first 2 to 3 hours of exposure, and then experienced some olfactory fatigue. A slightly elevated urinary thiocyanate level was observed in one subject, although no cyanide was detected in the blood. One week later, two of the subjects were exposed to 80 ppm for 4 hours with no adverse effects. Blood cyanide was not detected, and urinary thiocyanate excretion was not increased. Nine days later, exposure of the two subjects to 160 ppm for 4 hours caused a slight flushing of the face in one subject after 2 hours of exposure, and a feeling of bronchial tightness 5 hours later, despite the fact that no significant changes in blood cyanide or urinary thiocyanate occurred (Pozzani *et al.*, 1959a).

Symptoms of acute acetonitrile intoxication following the accidental poisoning of 15 workers at a chemical plant included irritation of the nose, throat, and skin, chest pain, tightness in the chest, tachycardia, hypotension, nausea, emesis, respiratory depression, headache, extreme weakness, semiconsciousness, convulsions, coma, and death (Amdur, 1959). Another fatal case of acute acetonitrile poisoning occurred when a laboratory worker poured acetonitrile and boiling water on the floor to clean it. Four hours after leaving work he complained of epigastric pain and nausea and vomited repeatedly. The following day he became comatose and had convulsions. Large amounts of cyanide, thiocyanate, and acetonitrile were found in his blood and urine and he died 6 days after the exposure (DeQuidt *et al.*, 1974).

Accidental dermal and inhalation exposures to acetonitrile contained in artificial fingernail remover have been reported in children, resulting in nausea, emesis, hypotension, and tachycardia. Accidental ingestion of artificial fingernail remover resulted in the death of another child (Caravati and Litovitz, 1988). Cases of suicidal ingestion of acetonitrile have resulted in death (Michaelis *et al.*, 1991) or recovery of the patient after vomiting, convulsions, coma,

acute respiratory insufficiency, severe metabolic acidosis, and cardiac arrest (Jaeger *et al.*, 1977). In two fatal cases of accidental ingestion, acetonitrile was detected in the blood (0.8 g/L), urine (1.0 g/L), and stomach contents (1.3 g/L) (Jones *et al.*, 1992). In other cases, successful treatment of patients with sodium nitrate and sodium thiosulfate has been reported following acetonitrile ingestion (Geller *et al.*, 1991; Turchen *et al.*, 1991).

## **REPRODUCTIVE AND DEVELOPMENTAL TOXICITY**

### **Experimental Animals**

Acetonitrile had no teratogenic potential in a chick embryo system (Levene, 1961). However, more recent studies have demonstrated a significant and dose-dependent increase in the number of abnormal fetuses in Syrian golden hamsters exposed to 5,000 or 8,000 ppm acetonitrile by inhalation on day 8 of gestation. Additional studies in pregnant hamsters demonstrated that single gavage doses of 300 to 400 mg/kg produced a significant increase in the number of malformed fetuses or resorptions, while single intraperitoneal injections of 200 to 400 mg/kg caused a significant increase only in the average fetal body weight compared to controls. Thus, the same dose given by gavage elicited greater toxic and teratogenic effects than when administered intraperitoneally (Willhite, 1983).

In a study with pregnant Charles River rats that received acetonitrile by gavage on gestation days 6 through 15, a dose of 275 mg/kg caused maternal body weight reduction and death and embryotoxic effects which included increases in early resorptions and post-implantation losses (Bertheau *et al.*, 1982). A similar study in Long-Evans rats given acetonitrile by gavage on gestation days 7 through 21 demonstrated maternal body weight reduction and death at 500 mg/kg, as well as fewer dams delivering viable litters at 300 and 500 mg/kg (Smith *et al.*, 1987). Pregnant rabbits administered 2, 15, or 30 mg/kg acetonitrile orally on gestation days 6 through 18 showed decreased body weight gain, and five out of 25 animals receiving 30 mg/kg died. Body weight gain was also reduced at 15 mg/kg. Embryotoxicity was observed only at the 30 mg/kg dose level. Consequently, acetonitrile is not considered to be toxic to fetuses at doses below those causing maternal toxicity (WHO, 1993).

This conclusion is supported by a more recent inhalation study in Sprague-Dawley rats exposed to acetonitrile at concentrations of 100, 400, or 1,200 ppm for 6 hours per day on gestation days 6 through 19 (NTP, 1994a). Despite the absence of significant exposure-related effects upon maternal body weight, reproductive indices, or the incidence of fetal malformations, a few maternal deaths occurred at the 1,200 ppm concentration, and one occurred at 400 ppm. Analysis results indicated significant, exposure-related concentrations of acetonitrile in the blood of all exposed groups and the presence of cyanide in the blood of the 1,200 ppm group (cyanide was also detected in the blood of one 400 ppm rat at each time point, but it could not be quantified). The concentration of cyanide in the blood of 1,200 ppm rats declined from approximately 2 mg/mL on gestation day 8 to approximately 0.8 mg/mL on day 18, while the acetonitrile concentration remained essentially constant during the same period. The decrease in the maternal blood cyanide level may have been due to induction of rhodanese, the enzyme thought to be responsible for the detoxification of cyanide (Klaassen *et al.*, 1986).

### **Humans**

No information related to the reproductive or developmental toxicity of acetonitrile in humans has been reported in the literature.

### **CARCINOGENICITY**

No carcinogenicity studies of acetonitrile in experimental animals or humans have been reported in the literature.

### **GENETIC TOXICITY**

Acetonitrile did not induce mutations in *Salmonella typhimurium* (Florin *et al.*, 1980; Maron *et al.*, 1981; Mortelmans *et al.*, 1986; Schlegelmilch *et al.*, 1988), in L5178Y mouse lymphoma cells (Rudd *et al.*, 1983), or in cultured Chinese hamster ovary cells (Bioassay Systems Corp., 1984). These tests were conducted with and without S9 metabolic activation enzymes. In cytogenetic tests with cultured Chinese hamster ovary cells, acetonitrile induced slight increases in sister chromatid exchanges without S9 and chromo-

somal aberrations with S9; these responses were judged to be equivocal (Galloway *et al.*, 1987). No induction of unscheduled DNA synthesis was observed in rat hepatocytes exposed *in vivo* or *in vitro* to acetonitrile (Mirsalis *et al.*, 1983).

In contrast to the essentially negative results that were obtained with acetonitrile in the assays described previously, positive results have been reported in assays that measure the induction of aneuploidy events. Acetonitrile induced sex chromosomal aneuploidy (both chromosome loss and chromosome gain) in oocytes of female *Drosophila melanogaster* fed an aqueous solution of the chemical either as larvae or as adults (Osgood *et al.*, 1991a,b). Acetonitrile was also found to be a potent inducer of aneuploidy, but not point mutations or recombination, in a diploid strain of *Saccharomyces cerevisiae*, although relatively high concentrations (approximately 5%) of acetonitrile were required to produce this effect (Zimmerman *et al.*, 1985; Whittaker *et al.*, 1989). In addition, weakly positive results were reported in a bone marrow micronucleus test with acetonitrile administered by intraperitoneal injection to male and female NMRI mice (Schlegelmilch *et al.*, 1988). However, this particular study did not include control micronucleus frequencies for comparison to the "induced" levels, and the data, therefore, cannot be critically evaluated.

In conclusion, acetonitrile was not active in gene mutation assays conducted either in bacteria or cultured mammalian cells, but positive results were reported in assays designed to detect chromosomal aberrations.

A metabolite of acetonitrile, hydrogen cyanide, was found to be a direct-acting mutagen (no requirement for S9 activation) in *Salmonella typhimurium* strain TA100 (Kushi *et al.*, 1983). Mutagenicity test data from the acetonitrile analogue propionitrile show the same pattern of activity demonstrated by acetonitrile; no mutagenicity in *Salmonella* was observed (Zeiger *et al.*, 1988), but there was induction of aneuploidy in *Saccharomyces cerevisiae* (Whittaker *et al.*, 1989, 1990; Zimmermann *et al.*, 1989) and in oocytes of female *Drosophila* exposed via inhalation or feeding (Osgood *et al.*, 1991a,b).

**STUDY RATIONALE**

The National Cancer Institute nominated acetonitrile for study because of its widespread use in manufacturing processes, its disposal by manufacturers when it occurs as a byproduct in the synthesis of acrylo-

nitrile, its high potential for worker exposure, as well as exposure of the general population due to its many noncaptive uses. Inhalation was chosen as the route of exposure to mimic the principal means of human exposure to acetonitrile.



## MATERIALS AND METHODS

### PROCUREMENT AND CHARACTERIZATION OF ACETONITRILE

Acetonitrile was obtained in three lots (2485, B082889, and V041381). Lot 2485 was obtained from E.I. DuPont de Nemours (Wilmington, DE) and was used throughout the 13-week studies and for the majority of the 2-year studies. Lots B082889 (J.T. Baker, Phillipsburg, N.J.) and V041381 (Vistron Corporation, Cleveland, OH) were used for a portion of the 2-year studies. Identity, purity, and stability analyses were conducted by the analytical chemistry laboratory, Midwest Research Institute (Kansas City, MO). Reports on analyses performed in support of the acetonitrile studies are on file at the National Institute of Environmental Health Sciences (NIEHS). The methods and results of these studies are detailed in Appendix H.

The chemical, a clear, colorless liquid, was identified as acetonitrile by infrared, ultraviolet/visible, and nuclear magnetic resonance spectroscopy. Purity of all lots was determined by elemental analyses, Karl Fischer water analysis, free acid titration, and gas chromatography. Elemental analyses for carbon, hydrogen, and nitrogen agreed with the theoretical values for acetonitrile. Karl Fischer water analysis indicated less than 0.2% for all lots. Titration indicated less than 35 ppm free acid. Gas chromatography using two systems indicated one major peak and no impurities with areas greater than 0.1% relative to the major peak for lots 2485 and B082889. For lot V041381, gas chromatography using one system indicated one major peak and one impurity with an area of 0.14% relative to the major peak, and gas chromatography using a second system indicated one major peak and no impurities with areas greater than 0.1% relative to the major peak. The overall purity for all lots was determined to be at least 99%.

Stability studies of the bulk chemical were performed by the analytical chemistry laboratory using gas chromatography. These studies indicated that acetonitrile was stable as a bulk chemical for at least 2 weeks when stored in tightly sealed containers

protected from light at temperatures up to 60° C. To ensure stability, the bulk chemical was stored at approximately 22° C in the original containers.

The study laboratory monitored the stability of the bulk chemical using gas chromatography and free acid titration. No degradation of the bulk chemical was detected.

### GENERATION AND MONITORING OF CHAMBER CONCENTRATIONS

Chamber concentrations were monitored with a single on-line HP-5840 gas chromatograph. The monitor was coupled with the inhalation chambers using an automated, multiplexed, 8-port (13-week studies) or 12-port (2-year studies) sampling valve. Calibration was accomplished by acquiring grab samples from each exposure chamber using dimethylformamide-filled, fritted-glass bubblers and a calibrated critical-orifice sampling system. These samples were analyzed against gravimetrically prepared standards using an off-line gas chromatograph. Chamber atmosphere uniformity was maintained throughout the 13-week and 2-year studies. The monthly mean exposure concentrations in the chambers during the 2-year studies are presented in Figures H6 through H11. Detailed descriptions of vapor generation and monitoring are given in Appendix H.

Buildup and decay rates for chamber concentrations were determined with and without animals present in the chambers. The time to achieve 90% of target concentrations after the start of vapor generation ( $T_{90}$ ) was determined to be 15 to 17 minutes in the 13-week studies and 10 to 15 minutes in the 2-year studies. The time for the chamber concentration to decay to 10% of the target concentration after vapor generation was terminated ( $T_{10}$ ) ranged from 12 to 14 minutes in the 13-week studies and 14 to 17 minutes in the 2-year studies. A  $T_{90}$  of 12 minutes was used in the 13-week and 2-year studies.

Uniformity of vapor concentration in the inhalation exposure chambers was confirmed during the 13-week and 2-year studies. Studies of acetonitrile degradation were conducted during the 13-week studies in the 100 and 1,600 ppm chambers, and during the 2-year studies in the 50 and 400 ppm chambers and in the vapor distribution line. The results of these analyses indicated that no test chemical degradation occurred in the chambers or in the vapor distribution line as a result of test chemical generation.

### 13-WEEK STUDIES

These studies were conducted to evaluate the cumulative toxic effects of repeated exposure to acetonitrile, and to determine the appropriate concentrations to be used in the 2-year studies.

Male and female F344/N rats and B6C3F<sub>1</sub> mice were obtained from Simonsen Laboratories (Gilroy, CA). Upon receipt, the rats and mice were approximately 4 weeks old. Animals were quarantined for 12 to 14 days and were approximately 6 weeks old on the first day of exposure. Prior to study start, five male and five female rats and mice were randomly selected for parasite evaluation and gross observation of disease. Serology samples were collected from an additional five male and five female rats and mice 3 weeks after their arrival for viral screening. At the end of the studies, serologic analyses were performed on sentinel animals using the protocols of the NTP Sentinel Animal Program (Appendix J).

Groups of 10 male and 10 female rats and mice were exposed to acetonitrile at concentrations of 0, 100, 200, 400, 800, or 1,600 ppm (equivalent to 0, 168, 335, 670, 1,340, or 2,681 mg/m<sup>3</sup>). The animals were exposed for 6 hours plus T<sub>90</sub> (12 minutes) per day, 5 days per week for 13 weeks (excluding two holidays). Feed was available *ad libitum*, except during exposure periods, and water was available *ad libitum*. Both rats and mice were housed individually. Clinical examinations were recorded weekly. The animals were weighed initially, weekly thereafter, and at the end of the studies. Details of the study design and animal maintenance are summarized in Table 1.

Clinical pathology studies were performed on 10 male and 10 female rats per exposure group at the end of the 13-week studies. The rats were anesthetized with

a 70% CO<sub>2</sub>:30% air mixture and blood was drawn from the retroorbital sinus. Blood for hematology determinations was placed in tubes containing potassium EDTA as the anticoagulant. Blood for thyroid hormone analyses was placed in tubes without anticoagulant, allowed to clot at room temperature, and centrifuged. The serum was separated and placed in plastic containers for storage at -70° C until the analyses were performed. Hematology determinations were performed on an Ortho ELT-8/ds hematology analyzer (Ortho Instruments, Westwood, MA). Leukocyte differential counts and morphologic evaluation of blood cells were determined by light microscopic examination of blood films stained with Wright-Giemsa. Reticulocyte counts were determined by light microscopy, using smears prepared by incubating equal volumes of whole blood and new methylene blue and a Miller disc for reticulocyte quantitation. Serum triiodothyronine (T<sub>3</sub>), thyroxine (T<sub>4</sub>), and thyroid-stimulating hormone (TSH) concentrations were determined by radioimmunoassay methods using a Packard Auto-Gamma scintillation spectrometer (Packard Instrument Company, Downers Grove, IL). Tri-Tab and Tetra-Tab commercial reagent kits (NML Organon Teknika Corp.) were used for the T<sub>3</sub> and T<sub>4</sub> assays. TSH concentration was measured using a double-antibody technique. The hematology and thyroid hormone parameters evaluated are listed in Table 1.

A necropsy was performed on all animals. The brain, heart, right and left kidneys, liver, lungs, right testis, and thymus of animals surviving until the end of the study were weighed. Tissues for microscopic examination were fixed and preserved in 10% neutral buffered formalin, processed, trimmed, embedded in paraffin, sectioned to a thickness of 5 to 6 μm, and stained with hematoxylin and eosin. A complete histopathologic examination was performed on all control and 1,600 ppm animals, on 800 ppm male rats and mice, and on 800 ppm female mice. Table 1 lists the tissues and organs that were examined.

### 2-YEAR STUDIES

#### Study Design

Groups of up to 56 male and 56 female rats were exposed to acetonitrile by inhalation at concentrations of 0, 100, 200, or 400 ppm (equivalent to 0, 168, 335, or 670 mg/m<sup>3</sup>) and groups of 60 male and 60 female mice were exposed to acetonitrile by



inhalation at concentrations of 0, 50, 100, or 200 ppm (equivalent to 0, 84, 168, or 335 mg/m<sup>3</sup>) for 6 hours per day, 5 days per week for 103 weeks. Eight male and eight female rats and 10 male and 10 female mice from each exposure group were evaluated at 15 months.

### Source and Specification of Animals

Male and female F344/N rats and B6C3F<sub>1</sub> mice were obtained from Simonsen Laboratories (Gilroy, CA) for use in the 2-year studies. Upon receipt the animals were 4 weeks old. Both rats and mice were quarantined for 15 days before the beginning of the studies and were approximately 6 weeks old on the first day of exposure. Prior to study start, five male and five female rats and mice were randomly selected for parasite evaluation and gross observation of disease. Serology samples were collected from an additional five male and five female rats and mice 3 weeks after their arrival for viral screening. During the studies, the health of the animals was monitored using the protocols of the NTP Sentinel Animal Program (Appendix J).

### Animal Maintenance

Rats and mice were housed individually. Feed was available *ad libitum*, except during periods of exposure, and water was available *ad libitum*. Cages and racks were rotated weekly. Further details of animal maintenance are given in Table 1. Information on feed composition and contaminants is provided in Appendix I.

### Clinical Examinations and Pathology

The animals were observed twice daily for mortality and signs of toxicity or moribundity. Individual clinical observations were recorded every 4 weeks. The animals were weighed initially, weekly for the first 13 weeks, and at 4-week intervals thereafter. During the final 13 weeks of the study, body weights and clinical findings were recorded every 2 weeks.

Eight male and up to eight female rats and 10 male and 10 female mice per exposure group were designated for interim evaluation at 15 months. Blood was taken from the retroorbital sinus of rats anesthetized with a 70% CO<sub>2</sub>:30% air mixture. Blood for hematology determinations was placed in tubes containing potassium EDTA as the anticoagulant. Hematology determinations were performed on an Ortho ELT-8/ds hematology analyzer. Leukocyte

differential and nucleated erythrocyte counts were determined by light microscopic examination of blood films stained with Wright-Giemsa. The hematology parameters evaluated at 15 months are listed in Table 1. The liver, right kidney, and lungs were weighed.

A complete necropsy and microscopic examination were performed on all rats and mice. All organs and tissues were examined for grossly visible lesions, and all major tissues were fixed and preserved in 10% neutral buffered formalin, processed, trimmed, embedded in paraffin, sectioned to a thickness of 5 to 6  $\mu$ m, and stained with hematoxylin and eosin for microscopic examination. For all paired organs (i.e., adrenal gland, kidney, and ovary), samples from each organ were examined. Tissues that were examined microscopically are listed in Table 1.

Microscopic evaluations were completed by the study laboratory pathologist, and the pathology data were entered into the Toxicology Data Management System. The microscopic slides, paraffin blocks, and residual wet tissues were sent to the NTP Archives for inventory, slide/block match, and wet tissue audit. The slides, individual animal data records, and pathology tables were evaluated by an independent quality assessment laboratory. The individual animal records and tables were compared for accuracy, the slide and tissue counts were verified, and the histo-technique was evaluated. For the 2-year studies, a quality assessment pathologist reviewed the lung of rats and mice, the liver of male rats and male and female mice, and the forestomach of female rats and male and female mice. Additional tissues reviewed for specific lesions included the pancreas and thyroid gland of rats; the adrenal medulla and testis of male rats; the liver of female rats; and the brain and kidneys of mice.

The quality assessment report and slides were submitted to the NTP Pathology Working Group (PWG) chair, who reviewed the selected tissues and any other tissues for which a disagreement in diagnosis between the laboratory and quality assessment pathologists existed. Representative histopathology slides containing examples of lesions related to chemical administration, examples of disagreements in diagnoses between the laboratory and quality assessment pathologist, or lesions of general interest were presented by the chair to the PWG for review. The

PWG consisted of the quality assessment pathologist and other pathologists experienced in rodent toxicologic pathology. This group examined the tissues without any knowledge of dose groups or previously rendered diagnoses. When the PWG consensus differed from the opinion of the laboratory pathologist, the diagnosis was changed. Thus, the final diagnoses represent a consensus of contractor pathologists and the PWG. Details of these review procedures have been described, in part, by Maronpot and Boorman (1982) and Boorman *et al.* (1985). For subsequent analyses of the pathology data, the diagnosed lesions for each tissue type were evaluated separately or combined according to the guidelines of McConnell *et al.* (1986).

## Statistical Methods

### Survival Analyses

The probability of survival was estimated by the product-limit procedure of Kaplan and Meier (1958) and is presented in the form of graphs. Animals found dead of other than natural causes were censored from the survival analyses; animals dying from natural causes were not censored. Statistical analyses for possible dose-related effects on survival used Cox's (1972) method for testing two groups for equality and Tarone's (1975) life table test to identify dose-related trends. All reported P values for the survival analyses are two sided.

### Calculation of Incidence

The incidences of neoplasms or nonneoplastic lesions as presented in Tables A1, A5, B1, B4, C1, C5, D1, and D5 are given as the number of animals bearing such lesions at a specific anatomic site and the number of animals with that site examined microscopically. For calculation of statistical significance, the incidences of most neoplasms (Tables A3, B3, C3, and D3) and all nonneoplastic lesions are given as the numbers of animals affected at each site examined microscopically. However, when macroscopic examination was required to detect neoplasms in certain tissues (e.g., skin, intestine, harderian gland, and mammary gland) before microscopic evaluation, or when neoplasms had multiple potential sites of occurrence (e.g., leukemia or lymphoma), the denominators consist of the number of animals on which a necropsy was performed. Tables A3, B3, C3, and D3 also give the survival-adjusted neoplasm rate for each group and each site-specific neoplasm, i.e., the

Kaplan-Meier estimate of the neoplasm incidence that would have been observed at the end of the study in the absence of mortality from all other competing risks (Kaplan and Meier, 1958).

### Analysis of Neoplasm Incidences

The majority of neoplasms in these studies were considered to be incidental to the cause of death or not rapidly lethal. Thus, the primary statistical method used was logistic regression analysis, which assumed that the diagnosed neoplasms were discovered as the result of death from an unrelated cause and thus did not affect the risk of death. In this approach, neoplasm prevalence was modeled as a logistic function of chemical exposure and time. Both linear and quadratic terms in time were incorporated initially, and the quadratic term was eliminated if the fit of the model was not significantly enhanced. The neoplasm incidences of exposed and control groups were compared on the basis of the likelihood score test for the regression coefficient of dose. This method of adjusting for intercurrent mortality is the prevalence analysis of Dinse and Lagakos (1983), further described and illustrated by Dinse and Haseman (1986). When neoplasms are incidental, this comparison of the time-specific neoplasm prevalences also provides a comparison of the time-specific neoplasm incidences (McKnight and Crowley, 1984).

In addition to logistic regression, other methods of statistical analysis were used, and the results of these tests are summarized in the appendixes. These methods include the life table test (Cox, 1972; Tarone, 1975), appropriate for rapidly lethal neoplasms, and the Fisher exact test and the Cochran-Armitage trend test (Armitage, 1971; Gart *et al.*, 1979), procedures based on the overall proportion of neoplasm-bearing animals.

Tests of significance included pairwise comparisons of each exposed group with controls and a test for an overall dose-related trend. Continuity-corrected tests were used in the analysis of neoplasm incidence, and reported P values are one sided. The procedures described in the preceding paragraphs were also used to evaluate selected nonneoplastic lesions. For further discussion of these statistical methods, refer to Haseman (1984).

### ***Analysis of Nonneoplastic Lesion Incidences***

Because all nonneoplastic lesions in this study were considered to be incidental to the cause of death or not rapidly lethal, the primary statistical analysis used was a logistic regression analysis in which nonneoplastic lesion prevalence was modeled as a logistic function of chemical exposure and time. For lesions detected at the interim evaluation, the Fisher exact test was used, a procedure based on the overall proportion of affected animals.

### ***Analysis of Continuous Variables***

Two approaches were employed to assess the significance of pairwise comparisons between exposed and control groups in the analysis of continuous variables. Organ and body weight data, which have approximately normal distributions, were analyzed using the parametric multiple comparison procedures of Dunnett (1955) and Williams (1971, 1972). Hematology and thyroid hormone assay data, which have typically skewed distributions, were analyzed using the nonparametric multiple comparison methods of Shirley (1977) and Dunn (1964). Jonckheere's test (1954) was used to assess the significance of the dose-related trends and to determine whether a trend-sensitive test (Williams' or Shirley's test) was more appropriate for pairwise comparisons than a test that does not assume a monotonic dose-related trend (Dunnett's or Dunn's test). Prior to analysis, extreme values identified by the outlier test of Dixon and Massey (1951) were examined by NTP personnel, and implausible values were eliminated from the analysis. Average severity values were analyzed for significance using the Mann-Whitney U test (Hollander and Wolfe, 1973).

### ***Historical Control Data***

Although the concurrent control group is always the first and most appropriate control group used for evaluation, historical control data can be helpful in the overall assessment of neoplasm incidence in certain instances. Consequently, neoplasm incidences from the NTP historical control database (Haseman *et al.*, 1984, 1985) are included in the NTP reports for neoplasms appearing to show compound-related effects.

### ***Quality Assurance Methods***

The 13-week and 2-year studies were conducted in compliance with Food and Drug Administration

Good Laboratory Practice Regulations (21 CFR, Part 58). In addition, as records from the 2-year studies were submitted to the NTP Archives, these studies were audited retrospectively by an independent quality assurance contractor. Separate audits covering completeness and accuracy of the pathology data, pathology specimens, final pathology tables, and draft of this NTP Technical Report were conducted. Audit procedures and findings are presented in the reports and are on file at NIEHS. The audit findings were reviewed and assessed by NTP staff, so all comments had been resolved or were otherwise addressed during the preparation of this Technical Report.

## **GENETIC TOXICOLOGY**

The genetic toxicity of acetonitrile was assessed by testing the ability of the chemical to induce mutations in various strains of *Salmonella typhimurium* and sister chromatid exchanges and chromosomal aberrations in cultured Chinese hamster ovary cells, and to increase the frequency of micronucleated erythrocytes in peripheral blood. The protocols for these studies and the results are given in Appendix E.

The genetic toxicity studies of acetonitrile are part of a larger effort by the NTP to develop a database that would permit the evaluation of carcinogenicity in experimental animals from the structure and responses of the chemical in short-term *in vitro* and *in vivo* genetic toxicity tests. These genetic toxicity tests were originally developed to study mechanisms of chemically induced DNA damage and to predict carcinogenicity in animals, based on the electrophilic theory of chemical carcinogenesis and the somatic mutation theory (Miller and Miller, 1977; Straus, 1981; Crawford, 1985).

There is a strong correlation between a chemical's potential electrophilicity (structural alert to DNA reactivity), mutagenicity in *Salmonella*, and carcinogenicity in rodents. The combination of electrophilicity and *Salmonella* mutagenicity is highly correlated with the induction of carcinogenicity in rats and mice and/or at multiple tissue sites (Ashby and Tennant, 1991). Other *in vitro* genetic toxicity tests do not correlate well with rodent carcinogenicity (Tennant *et al.*, 1987; Zeiger *et al.*, 1990), although these other tests can provide information on the types of DNA and chromosome effects that can be

induced by the chemical being investigated. Data from NTP studies show that a positive response in *Salmonella* is currently the most predictive *in vitro* test for rodent carcinogenicity (89% of the *Salmonella* mutagens were rodent carcinogens), and that there is no complementarity among the *in vitro*

genetic toxicity tests. That is, no battery of tests that included the *Salmonella* test improved the predictivity of the *Salmonella* test alone. The predictivity for rodent carcinogenicity of a positive response in rodent bone marrow micronucleus tests is still being evaluated.

**TABLE 1**  
**Experimental Design and Materials and Methods in the Inhalation Studies of Acetonitrile**

13-Week Studies	2-Year Studies
<b>Study Laboratory</b> Battelle Pacific Northwest Laboratories (Richland, WA)	Battelle Pacific Northwest Laboratories (Richland, WA)
<b>Strain and Species</b> Rats: F344/N Mice: B6C3F <sub>1</sub>	Rats: F344/N Mice: B6C3F <sub>1</sub>
<b>Animal Source</b> Simonsen Laboratories (Gilroy, CA)	Simonsen Laboratories (Gilroy, CA)
<b>Time Held Before Studies</b> Rats: 12 days Mice: 14 days	15 days
<b>Average Age When Studies Began</b> 6 weeks	6 weeks
<b>Date of First Dose</b> Rats: 8 April 1986 Mice: 10 April 1986	Rats: 31 March 1988 Mice: 7 April 1988
<b>Duration of Dosing</b> 6 hours per day, 5 days per week for 13 weeks (excluding 2 holidays)	6 hours per day, 5 days per week for 103 weeks (excluding 2 holidays, 7 unscheduled early terminations of exposure, and 1 day of nonexposure)
<b>Date of Last Dose</b> Rats: 8-9 July 1986 Mice: 9-10 July 1986	Rats: 15-Month interim evaluation: 28-29 June 1989 Terminal: 23 March 1990 Mice: 15-Month interim evaluation: 5-6 July 1989 Terminal: 30 March 1990
<b>Necropsy Dates</b> Rats: 8-9 July 1986 Mice: 9-10 July 1986	Rats: 15-Month interim evaluation: 29-30 June 1989 Terminal: 2-4 April 1990 Mice: 15-Month interim evaluation: 6-7 July 1989 Terminal: 9-12 April 1990

**TABLE 1**  
**Experimental Design and Materials and Methods in the Inhalation Studies of Acetonitrile** (continued)

13-Week Studies	2-Year Studies
<b>Average Age at Necropsy</b> 19 weeks	15-Month interim evaluation: 72 weeks Terminal: 111 weeks
<b>Size of Study Groups</b> 10 males and 10 females	Rats: 15-Month interim evaluation: 8 males and 8 females Terminal: up to 48 males and 48 females Mice: 15-Month interim evaluation: 10 males and 10 females Terminal: 50 males and 50 females
<b>Method of Animal Distribution</b> Animals were randomly assigned to exposure and control groups using the XYBION PATH/TOX SYSTEM (XYBION Medical Systems Corp., Cedar Knolls, NJ), with body weight as the blocking variable.	Same as 13-week studies
<b>Animals per Cage</b> 1	1
<b>Method of Identification</b> Toe clip and cage position during exposure	Rats: tail tattoo and cage position during exposure Mice: toe clip and cage position during exposure
<b>Diet</b> NIH-07 diet/pelleted (Zeigler Brothers, Inc., Gardners, PA); available <i>ad libitum</i> , except during exposure periods.	Same as 13-week studies
<b>Water Distribution</b> Tap water (Richland municipal supply) softened (Illinois Water Treatment Company, Rockford, IL) and supplied via automatic watering system (Edstrom Industries, Waterford, WI); available <i>ad libitum</i> .	Same as 13-week studies
<b>Cages</b> Stainless steel wire bottom cages (Lab Products, Inc., Aberdeen, MD); cage units changed weekly and rotated in chamber weekly	Same as 13-week studies
<b>Bedding/Cage Board</b> Sani-Chips (P.J. Murphy Forest Products, Rochelle Park, NY) during quarantine period; none used during study period	Untreated Shepard Specialty Papers (Kalamazoo, MI)
<b>Chamber Air Supply Filters</b> Single HEPA (Flanders Filters, Inc., San Rafael, CA) and charcoal (RSE, Inc., New Baltimore, MI)	Same as 13-week studies

**TABLE 1**  
**Experimental Design and Materials and Methods in the Inhalation Studies of Acetonitrile** (continued)

13-Week Studies	2-Year Studies
<p><b>Chambers</b>            Stainless steel (Lab Products, Aberdeen, MD),            changed weekly</p>	<p>Same as 13-week studies</p>
<p><b>Chamber Environment</b>            Temperature: 19.1°-27.4° C (rats); 21.0°-27.4° C (mice)            Relative humidity: 30%-75%            Fluorescent light: 12 hours/day</p>	<p>Temperature: 20.9°-26.8° C (rats), 20.5°-26.7° C (mice)            Relative humidity: 55.3%-57.8% (rats), 54.0%-54.4% (mice)            Fluorescent light: 12 hours/day</p>
<p><b>Doses</b>            0, 100, 200, 400, 800, or 1,600 ppm (equivalent to 0, 168, 335,            670, 1,340, or 2,681 mg/m<sup>3</sup>)</p>	<p>Rats: 0, 100, 200, or 400 ppm (equivalent to 0, 168, 335, or            670 mg/m<sup>3</sup>)            Mice: 0, 50, 100, or 200 ppm (equivalent to 0, 84, 168, or            335 mg/m<sup>3</sup>)</p>
<p><b>Type and Frequency of Observation</b>            Animals were observed twice daily; clinical observations were            recorded weekly. Body weights were recorded weekly for            13 weeks in rats and 12 weeks in mice.</p>	<p>Animals were observed twice daily; clinical observations were            recorded monthly. Body weights were recorded initially, weekly            for the first 13 weeks, and monthly thereafter. During the final            13 weeks, clinical observations and body weights were recorded            every 2 weeks.</p>
<p><b>Method of Sacrifice</b>            70% carbon dioxide asphyxiation</p>	<p>Anesthetization with 70% carbon dioxide followed by            exsanguination via the brachial artery</p>
<p><b>Necropsy</b>            Necropsies were performed on all animals. Organs weighed            were brain, heart, right and left kidneys, liver, lungs, right testis,            and thymus.</p>	<p>Necropsies were performed on all animals. Organs weighed at            the 15-month interim evaluations were liver, lungs, and right            kidney.</p>
<p><b>Clinical Pathology</b>            Blood was taken from the retroorbital sinus of all rats surviving            to study termination for clinical pathology.  <b>Hematology:</b> hematocrit, hemoglobin concentration, erythrocyte            counts, mean cell volume, mean cell hemoglobin, mean cell            hemoglobin concentration, total leukocyte counts and            differentials, reticulocyte counts, and platelet counts.  <b>Thyroid hormone assays:</b> triiodothyronine (T<sub>3</sub>), thyroxine (T<sub>4</sub>),            and thyroid-stimulating hormone (TSH) concentrations.</p>	<p>Blood was taken from the retroorbital sinus of rats at the            15-month interim evaluation.  <b>Hematology:</b> hematocrit, hemoglobin concentration, erythrocyte            counts, mean cell volume, mean cell hemoglobin, mean cell            hemoglobin concentration, total leukocyte counts and            differentials, reticulocyte counts, platelet counts, and nucleated            erythrocyte counts.</p>

**TABLE 1**  
**Experimental Design and Materials and Methods in the Inhalation Studies of Acetonitrile** (continued)

13-Week Studies	2-Year Studies
<p><b>Histopathology</b></p> <p>Complete histopathologic examinations were performed on 0, 800 (excluding female rats), and 1,600 ppm rats and mice. In addition to gross lesions and tissue masses with regional lymph nodes, tissues examined included: adrenal gland, brain, bone and marrow, clitoral gland (rats), esophagus, gallbladder (mice), heart, kidney, large intestine (colon, cecum, rectum), larynx, liver, lung, lymph nodes (bronchial, mandibular, mediastinal, and mesenteric), mammary gland, nose (3 levels), ovary, pancreas, parathyroid gland, pituitary gland, preputial gland (rats), prostate gland, salivary gland, skin, small intestine (duodenum, jejunum, ileum), spleen, stomach (forestomach and glandular), testis, thymus, thyroid gland, trachea, urinary bladder, and uterus. Selected organs examined in rats included: bone and marrow, brain, lung, mesenteric lymph node, ovary, spleen, and thymus of 800 ppm females; and bone and marrow, testes, and thymus of 400 ppm males. Selected organs in mice included: adrenal gland of 200 and 400 ppm females; liver of 200 and 400 ppm males and females; lung of 400 ppm females; stomach of 200 and 400 ppm males and all females; and thymus of 400 ppm females.</p>	<p>Complete histopathologic examinations were performed on all animals. In addition to gross lesions and tissue masses with regional lymph nodes, tissues examined included: adrenal gland, brain, bone and marrow, clitoral gland, esophagus, gallbladder (mice), heart, kidney, large intestine (colon, cecum, rectum), larynx, liver, lung, lymph nodes (bronchial, mandibular, mediastinal, and mesenteric), mammary gland, nose, ovary, parathyroid gland, pituitary gland, preputial gland, prostate gland, salivary gland, seminal vesicle, skin, small intestine (duodenum, jejunum, ileum), spleen, stomach (forestomach and glandular), testis, thymus, thyroid gland, trachea, urinary bladder, and uterus.</p>



## RESULTS

### RATS

#### 13-WEEK STUDY

Six male and three female rats exposed by inhalation to acetonitrile concentrations of 1,600 ppm and one male exposed to 800 ppm died during the study; all but one of these deaths occurred during the first 2 weeks of the study (Table 2). At exposure concentrations up to and including 800 ppm, final mean body weights and body weight gains were similar to

those of the controls. At the 1,600 ppm concentration, body weight gains were lower than those of the controls; the final mean body weights were 81% of the control value in males and 91% of the control value in females (Table 2). Hypoactivity and ruffled fur were observed in 800 ppm males and 1,600 ppm males and females during the first week of the study. Additional clinical findings in 1,600 ppm males that died during week 1 were ataxia, abnormal posture,

**TABLE 2**  
**Survival and Body Weights of Rats in the 13-Week Inhalation Study of Acetonitrile**

Dose (ppm)	Survival <sup>a</sup>	Mean Body Weight <sup>b</sup> (g)			Final Weight Relative to Controls (%)
		Initial	Final	Change	
<b>Male</b>					
0	10/10	115 ± 2	336 ± 4	220 ± 4	
100	10/10	118 ± 2	343 ± 5	225 ± 4	102
200	10/10	121 ± 3	352 ± 5	231 ± 4	105
400	10/10	118 ± 2	339 ± 5	221 ± 4	101
800	9/10 <sup>c</sup>	117 ± 3	338 ± 7	222 ± 6	101
1,600	4/10 <sup>d</sup>	119 ± 2	272 ± 11 <sup>**</sup>	153 ± 10 <sup>**</sup>	81
<b>Female</b>					
0	10/10	97 ± 2	197 ± 4	99 ± 3	
100	10/10	97 ± 2	190 ± 4	92 ± 3	96
200	10/10	98 ± 2	200 ± 4	102 ± 3	102
400	10/10	96 ± 2	209 ± 5	113 ± 4*	106
800	10/10	98 ± 2	203 ± 3	105 ± 3	103
1,600	7/10 <sup>e</sup>	95 ± 1	180 ± 4*	85 ± 3*	91

\* Significantly different ( $P \leq 0.05$ ) from the control group by Dunnett's test.

\*\*  $P \leq 0.01$

<sup>a</sup> Number of animals surviving at 13 weeks/number initially in group

<sup>b</sup> Weights and weight changes are given as mean ± standard error. Subsequent calculations are based on animals surviving to the end of the study.

<sup>c</sup> Week of death: 1

<sup>d</sup> Week of death: 1, 1, 1, 1, 2, 4

<sup>e</sup> Week of death: 1, 2, 2

and clonic convulsions. No other treatment-related clinical findings were observed. Absolute and relative thymus weights of 800 and 1,600 ppm males and females were significantly lower than those of the controls (Table F1). Females exposed to 1,600 ppm had significantly greater absolute and relative heart, kidney, and liver weights than those of the controls. No other organ weight differences were considered biologically significant.

An anemia, evidenced by decreases in red blood cell count, hemoglobin concentration, and hematocrit, occurred in the 1,600 ppm males and females and in 800 ppm female rats (Table G1). The anemia was characterized as nonresponsive, normocytic, and normochromic because the reticulocyte counts, mean cell volume, and mean cell hemoglobin concentrations in these groups were similar to those of the controls. In the 1,600 ppm female rats, decreases in triiodothyronine ( $T_3$ ) concentration occurred in the

absence of alterations in thyroxine ( $T_4$ ) and thyroid-stimulating hormone (TSH) concentrations. Minor, sporadic changes in other parameters were considered unrelated to treatment.

Gross and histopathologic changes were restricted to the 800 ppm male and 1,600 ppm male and female rats that died during the study. These included lung lesions consisting of congestion; edema; hemorrhage in alveoli; and a spectrum of lesions typically noted primarily in animals dying early that included brain hemorrhage, cellular depletion of the bone marrow, thymic atrophy, lymphoid depletion of the spleen (females), and depletion of corpora lutea in the ovary.

*Dose Selection Rationale:* Based on reduced survival, acetonitrile exposure concentrations selected for the 2-year inhalation study in rats were 100, 200, and 400 ppm.

## 2-YEAR STUDY

### Survival

Estimates of 2-year survival probabilities for male and female rats are shown in Table 3 and in the Kaplan-Meier survival curves in Figure 1. Survival rates of exposed rats were similar to those of the controls.

### Body Weights and Clinical Findings

Exposure to acetonitrile by inhalation for 15 months or 2 years had no effect on body weight gain or final mean body weights (Figure 2, Tables 4 and 5), and

the behavior, general health, and appearance of exposed male and female rats were similar to those of the controls throughout the study.

### Hematology

At the 15-month interim evaluation, the hematocrit value, hemoglobin concentration, erythrocyte count, mean cell volume, and mean cell hemoglobin in 400 ppm female rats were minimally lower than those of the controls (Table G2). Mean cell volume and mean cell hemoglobin in 400 ppm males were also minimally lower than controls; however, the erythrocyte count was slightly greater than that of controls.

**TABLE 3**  
**Survival of Rats in the 2-Year Inhalation Study of Acetonitrile**

	0 ppm	100 ppm	200 ppm	400 ppm
<b>Male</b>				
Animals initially in study	56	55	56	56
15-Month interim evaluation <sup>a</sup>	8	8	8	8
Moribund	36	26	35	26
Natural deaths	1	8	4	5
Animals surviving to study termination	11	13	9	17
Percent probability of survival at end of study <sup>b</sup>	23	28	19	35
Mean survival (days) <sup>c</sup>	613	614	606	641
Survival analysis <sup>d</sup>	P=0.141N	P=0.746N	P=0.667	P=0.137N
<b>Female</b>				
Animals initially in study	56	56	56	56
15-Month interim evaluation <sup>a</sup>	8	8	8	8
Accidental death <sup>a</sup>	1	0	0	0
Moribund	24	25	21	14
Natural deaths	0	2	1	5
Animals surviving to study termination	23	21	26	29
Percent probability of survival at end of study	50	44	55	61
Mean survival (days)	622	647	638	661
Survival analysis	P=0.166N	P=0.752	P=0.843N	P=0.290N

<sup>a</sup> Censored from survival analyses

<sup>b</sup> Kaplan-Meier determinations based on the number of animals alive on the first day of terminal sacrifice

<sup>c</sup> Mean of all deaths (uncensored, censored, and terminal sacrifice)

<sup>d</sup> The result of the life table trend test (Tarone, 1975) is in the control column, and the results of the life table pairwise comparisons (Cox, 1972) with the controls are in the exposed columns. A negative trend or lower mortality in an exposure group is indicated by N.

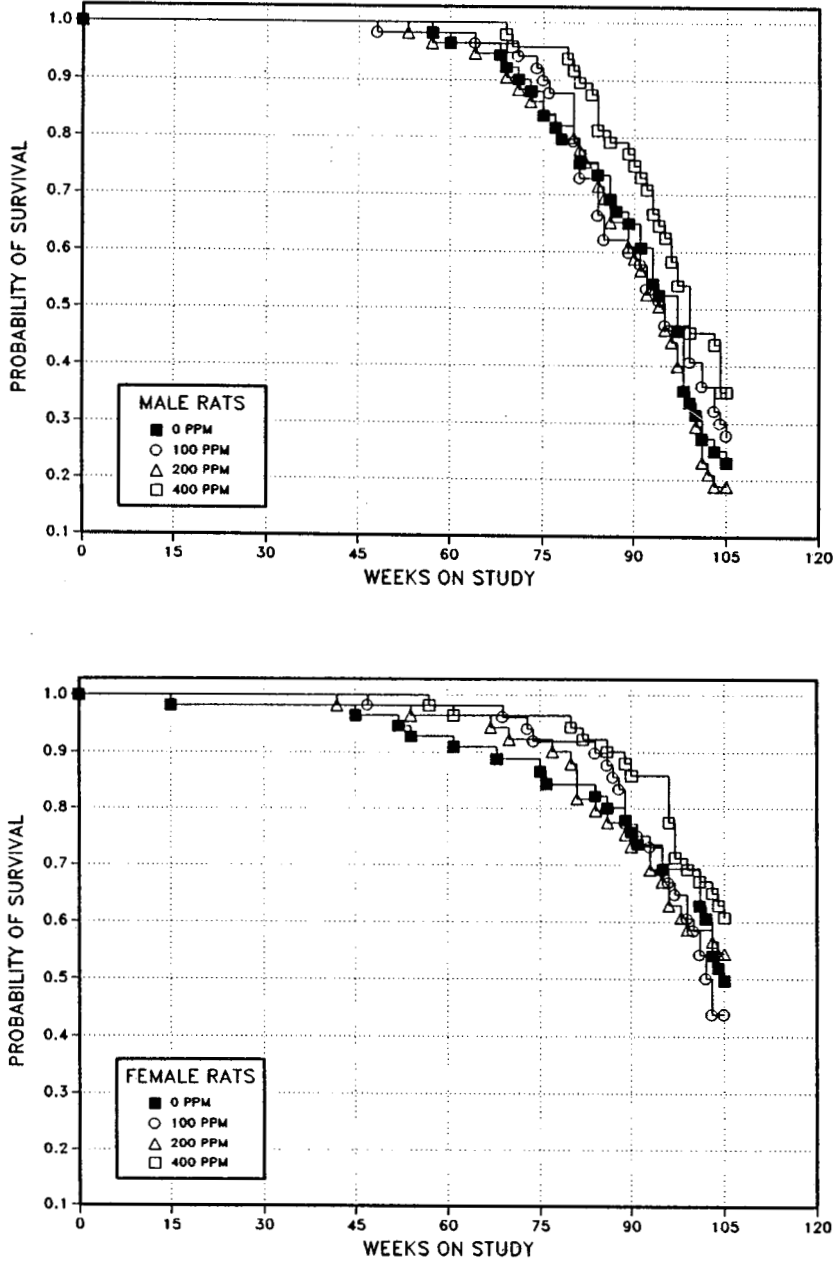

**FIGURE 1**  
**Kaplan-Meier Survival Curves for Rats Administered Acetonitrile**  
**by Inhalation for 2 Years**

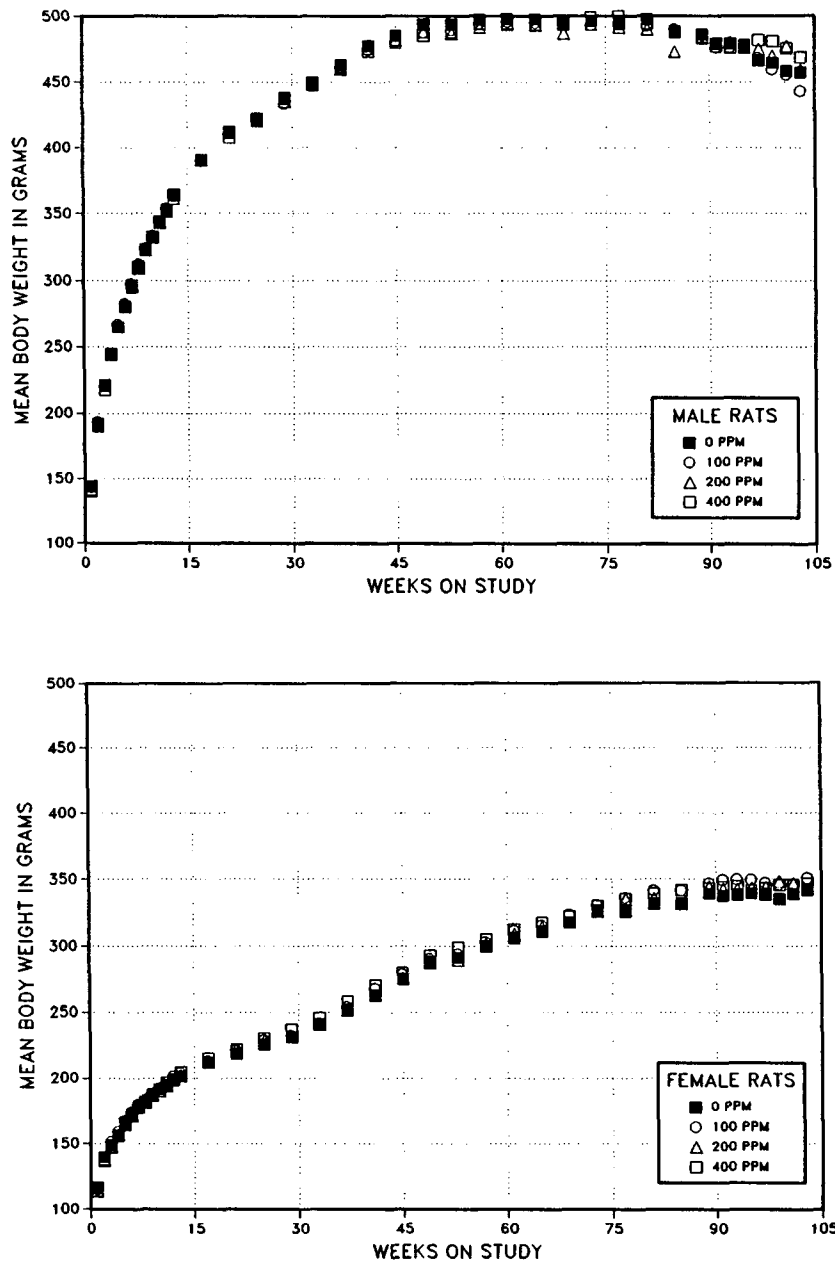

**FIGURE 2**  
**Growth Curves for Rats Administered Acetonitrile by Inhalation for 2 Years**

**TABLE 4**  
**Mean Body Weights and Survival of Male Rats in the 2-Year Inhalation Study of Acetonitrile**

Weeks on Study	0 ppm		100 ppm			200 ppm			400 ppm		
	Av. Wt. (g)	No. of Survivors	Av. Wt. (g)	Wt. (% of controls)	No. of Survivors	Av. Wt. (g)	Wt. (% of controls)	No. of Survivors	Av. Wt. (g)	Wt. (% of controls)	No. of Survivors
1	144	56	143	99	55	142	98	56	140	97	56
2	192	56	193	100	55	192	100	56	190	99	56
3	221	56	221	100	55	221	100	56	218	98	56
4	245	56	245	100	55	245	100	56	244	100	56
5	265	56	267	101	55	266	100	56	265	100	56
6	280	56	283	101	55	282	101	56	281	100	56
7	297	56	298	101	55	296	100	56	295	100	56
8	311	56	312	101	55	310	100	56	309	100	56
9	324	56	325	100	55	323	100	56	323	100	56
10	332	56	334	100	55	333	100	56	333	100	56
11	344	56	344	100	55	344	100	56	343	100	56
12	353	56	354	100	55	352	100	56	352	100	56
13	364	56	363	100	55	362	99	56	365	100	56
17	391	56	390	100	55	391	100	56	391	100	56
21	412	56	411	100	55	412	100	56	408	99	56
25	422	56	421	100	55	421	100	56	422	100	56
29	438	56	434	99	55	436	99	56	437	100	56
33	450	56	447	99	55	448	100	56	449	100	56
37	463	56	462	100	55	460	99	56	461	100	56
41	478	56	474	99	55	476	100	56	473	99	56
45	485	56	480	99	55	482	99	56	480	99	56
49	494	56	488	99	54	488	99	56	485	98	56
53	494	56	490	99	54	487	99	56	488	99	56
57	497	55	494	99	54	491	99	54	494	99	56
61	498	54	496	100	54	495	99	54	494	99	56
65	498	54	495	99	53	493	99	53	494	99	56
69 <sup>a</sup>	493	45	495	100	45	487	99	44	494	100	48
73	497	42	493	99	44	494	99	41	499	101	46
77	494	40	494	100	41	492	100	40	500	101	46
81	498	36	493	99	34	490	99	37	494	99	43
85	489	35	490	100	30	473	97	33	488	100	39
89	486	31	486	100	28	485	100	29	483	99	37
91	479	29	476	99	27	479	100	27	477	100	35
93	479	26	476	99	25	480	100	25	476	99	32
95	479	25	478	100	22	476	100	22	477	100	30
97	467	23	468	100	22	475	102	19	482	103	26
99	465	16	460	99	19	470	101	16	481	103	22
101	459	13	456	99	17	477	104	11	476	104	22
103	458	12	443	97	15	459	100	9	469	103	21
<b>Mean for weeks</b>											
1-13	282		283	100		282	100		281	100	
14-52	448		445	99		446	100		445	99	
53-103	484		481	99		483	100		486	100	

<sup>a</sup> Interim evaluation occurred during week 66.

**TABLE 5**  
**Mean Body Weights and Survival of Female Rats in the 2-Year Inhalation Study of Acetonitrile**

Weeks on Study	0 ppm		100 ppm			200 ppm			400 ppm		
	Av. Wt. (g)	No. of Survivors	Av. Wt. (g)	Wt. (% of controls)	No. of Survivors	Av. Wt. (g)	Wt. (% of controls)	No. of Survivors	Av. Wt. (g)	Wt. (% of controls)	No. of Survivors
1	117	56	115	99	56	114	98	56	113	97	56
2	140	56	140	100	56	138	99	56	137	98	56
3	149	56	151	102	56	149	100	56	147	99	56
4	156	56	159	102	56	157	100	56	156	100	56
5	164	56	168	102	56	167	101	56	166	101	56
6	171	56	174	102	56	172	101	56	173	101	56
7	179	56	180	101	56	178	100	56	177	99	56
8	182	56	184	101	56	182	100	56	182	100	56
9	187	56	188	100	56	187	100	56	187	100	56
10	191	56	192	101	56	190	99	56	191	100	56
11	195	56	196	101	56	194	100	56	197	101	56
12	198	56	201	102	56	199	100	56	199	101	56
13	201	56	204	102	56	202	101	56	205	102	56
17	212	55	213	101	56	213	101	56	215	102	56
21	218	55	221	101	56	222	102	56	222	102	56
25	226	55	229	102	56	229	101	56	230	102	56
29	231	55	233	101	56	233	101	56	237	103	56
33	241	55	241	100	56	241	100	56	246	102	56
37	252	55	254	101	56	252	100	56	258	102	56
41	263	55	268	102	56	263	100	56	270	103	56
45	275	54	279	101	56	276	101	55	280	102	56
49	288	53	290	101	55	287	100	55	293	102	56
53	292	52	294	101	55	290	99	55	299	103	56
57	300	51	303	101	55	301	101	54	305	102	55
61	306	51	312	102	55	309	101	54	313	102	54
65	311	50	316	101	55	314	101	54	317	102	54
69 <sup>a</sup>	318	41	324	102	46	318	100	45	322	101	46
73	327	41	331	101	45	326	100	44	330	101	46
77	326	39	336	103	44	335	103	43	335	103	46
81	332	39	342	103	44	336	101	39	339	102	45
85	332	38	342	103	43	332	100	38	342	103	44
89	339	36	347	102	37	345	102	36	343	101	42
91	338	34	349	103	36	343	102	35	344	102	41
93	339	34	350	103	35	343	101	33	345	102	41
95	340	33	350	103	33	344	101	32	342	101	41
97	338	32	347	103	31	344	102	30	343	101	34
99	336	32	346	103	29	349	104	28	346	103	33
101	339	29	346	102	26	347	102	28	346	102	32
103	342	25	351	103	21	343	100	27	347	101	31
<b>Mean for weeks</b>											
1-13	172		173	101		171	99		172	100	
14-52	245		248	101		246	100		250	102	
53-103	327		334	102		331	101		333	102	

<sup>a</sup> Interim evaluation occurred during week 66.

### *Pathology and Statistical Analyses*

This section describes the statistically significant or biologically noteworthy changes in the incidences of nonneoplastic lesions and neoplasms of the liver and other organs. Summaries of the incidences of neoplasms and nonneoplastic lesions, individual animal tumor diagnoses, statistical analyses of primary neoplasms that occurred with an incidence of at least 5% in at least one animal group, and historical incidences for the neoplasms mentioned in this section are presented in Appendix A for male rats and Appendix B for female rats.

*Liver:* The incidences of hepatocellular adenoma, hepatocellular carcinoma, and hepatocellular adenoma or carcinoma (combined) occurred with a statistically significant positive trend in males (Tables 6 and A3). However, pairwise comparisons between exposure groups and controls were not significantly different, and the incidence of hepatocellular adenoma or carcinoma (combined) in the 400 ppm group of males was only slightly greater than the historical range for inhalation study controls (Tables 6 and A4a). The incidence of basophilic foci was greater in 200 and 400 ppm males than that in controls, and the incidences of eosinophilic and mixed cell foci were marginally greater in 400 ppm males than those in controls (Tables 6 and A5). The incidences of liver lesions in exposed female groups were similar to those in the controls (Tables B1 and B4).

*Other organs:* In the adrenal medulla, the incidences of benign pheochromocytoma and benign or malignant pheochromocytoma (combined) were increased in 100 and 200 ppm male rats [benign pheochromocytoma: 0 ppm, 4/48; 100 ppm, 14/46; 200 ppm, 12/48; 400 ppm, 7/48; benign or malignant pheochromocytoma (combined): 4/48, 15/46, 14/48, 8/48; Tables A1 and A3]. In addition, the incidence of adenoma or carcinoma (combined) of the pancreatic islets was also increased in the 200 ppm males (2/48, 4/47, 8/48, 2/48; Tables A1 and A3). However, in both the adrenal medulla and the pancreatic islets, the increases in neoplasm incidences were marginal; the incidences of benign or malignant pheochromocytoma (combined) and of pancreatic islet adenoma or carcinoma (combined) in the controls were low when compared to historical controls (Tables A4b and A4c), and incidences in the 400 ppm group were not significantly increased. Therefore, these increased incidences were considered to be due to chance; in fact, higher incidences of these neoplasms have been observed in certain historical control groups. Although the increased incidence of keratoacanthoma in the skin occurred with a statistically significant trend (0/48, 1/47, 0/48, 4/48; Tables A1 and A3), the increase was not considered to be due to chemical exposure. No keratoacanthomas were observed in the control group, and the incidence of keratoacanthomas in 400 ppm males was within the historical control range (0%-8%, Table A4d).



**TABLE 6**  
**Incidences of Neoplasms and Nonneoplastic Lesions of the Liver of Male Rats**  
**in the 2-Year Inhalation Study of Acetonitrile**

Dose	0 ppm	100 ppm	200 ppm	400 ppm
<b>15-Month Interim Evaluation</b>				
Number Examined	8	8	8	8
Basophilic Focus <sup>a</sup>	6	6	7	7
Clear Cell Focus	3	0	0	2
<b>2-Year Study</b>				
Number Examined	48	47	48	48
Basophilic Focus	15	22	25*	31**
Clear Cell Focus	3	1	2	5
Eosinophilic Focus	3	7	5	10
Mixed Cell Focus	1	1	1	5
<b>Hepatocellular Adenoma<sup>b</sup></b>				
Overall rate <sup>c</sup>	0/48 (0%)	1/47 (2%)	1/48 (2%)	3/48 (6%)
Adjusted rate <sup>d</sup>	0.0%	3.4%	4.8%	16.2%
Terminal rate <sup>e</sup>	0/11 (0%)	0/13 (0%)	0/9 (0%)	2/17 (12%)
First incidence (days)	— <sup>g</sup>	623	673	727
Logistic regression test <sup>f</sup>	P=0.083	P=0.495	P=0.492	P=0.204
<b>Hepatocellular Carcinoma<sup>h</sup></b>				
Overall rate	1/48 (2%)	0/47 (0%)	0/48 (0%)	3/48 (6%)
Adjusted rate	3.3%	0.0%	0.0%	14.5%
Terminal rate	0/11 (0%)	0/13 (0%)	0/9 (0%)	1/17 (6%)
First incidence (days)	637	—	—	693
Logistic regression test	P=0.121	P=0.504N	P=0.500N	P=0.374
<b>Hepatocellular Adenoma or Carcinoma<sup>i</sup></b>				
Overall rate	1/48 (2%)	1/47 (2%)	1/48 (2%)	5/48 (10%)
Adjusted rate	3.3%	3.4%	4.8%	25.2%
Terminal rate	0/11 (0%)	0/13 (0%)	0/9 (0%)	3/17 (18%)
First incidence (days)	637	623	673	693
Logistic regression test	P=0.045	P=0.757	P=0.758	P=0.164

\* Significantly different ( $P \leq 0.05$ ) from the control by the logistic regression test.

\*\*  $P \leq 0.01$

<sup>a</sup> Number of animals with lesion

<sup>b</sup> Historical incidence for 2-year inhalation studies with control groups (mean  $\pm$  standard deviation): 11/398 (2.8%  $\pm$  2.6%); range, 0%-8%

<sup>c</sup> Number of animals with neoplasm per number of animals with liver examined microscopically

<sup>d</sup> Kaplan-Meier estimated neoplasm incidence at the end of the study after adjustment for intercurrent mortality

<sup>e</sup> Observed incidence in animals surviving until the end of the study

<sup>f</sup> In the control column are the P values associated with the trend test. In the exposed group columns are the P values corresponding to the pairwise comparisons between the controls and that exposed group. The logistic regression test regards these lesions as nonfatal. A lower incidence in an exposure group is indicated by N.

<sup>g</sup> Not applicable; no neoplasms in animal group

<sup>h</sup> Historical incidence: 4/398 (1.0%  $\pm$  1.5%); range, 0%-4%

<sup>i</sup> Historical incidence: 15/398 (3.8%  $\pm$  2.7%); range, 2%-8%

## MICE

### 13-WEEK STUDY

All male and female mice in the 1,600 ppm groups died by week 3 of the study. Six additional animals, one female receiving 400 ppm and one male and four females receiving 800 ppm also died before the end of the study (Table 7). The final mean body weights and body weight gains of all exposed groups of females that survived were similar to those of the

controls. The final mean body weights of all exposed male groups were slightly lower than that of the controls. Hypoactivity and a hunched, rigid posture were observed in 800 and 1,600 ppm mice during the first week of the study. These findings did not recur during the remainder of the study, and no other treatment-related findings were observed in any group.

TABLE 7  
Survival and Body Weights of Mice in the 13-Week Inhalation Study of Acetonitrile

Dose (ppm)	Survival <sup>a</sup>	Mean Body Weight <sup>b</sup> (g)			Final Weight Relative to Controls (%)
		Initial	Final <sup>c</sup>	Change	
<b>Male</b>					
0	10/10	25.4 ± 0.3	35.1 ± 0.5	9.7 ± 0.5	
100	10/10	25.0 ± 0.4	32.9 ± 0.5	8.0 ± 0.6	94
200	10/10	24.7 ± 0.2	34.2 ± 0.5	9.5 ± 0.5	97
400	10/10	24.8 ± 0.2	33.7 ± 0.7	8.9 ± 0.6	96
800	9/10 <sup>d</sup>	25.1 ± 0.3	32.5 ± 0.5**	7.3 ± 0.4*	92
1,600	0/10 <sup>e</sup>	25.1 ± 0.2	-	-	-
<b>Female</b>					
0	10/10	21.1 ± 0.3	29.4 ± 0.9	8.3 ± 0.7	
100	10/10	21.0 ± 0.4	29.9 ± 0.7	8.9 ± 0.6	102
200	10/10	20.3 ± 0.2	29.9 ± 0.8	9.5 ± 0.7	102
400	9/10 <sup>f</sup>	20.2 ± 0.3	29.0 ± 0.4	8.6 ± 0.5	99
800	6/10 <sup>g</sup>	20.4 ± 0.3	30.2 ± 0.9	9.7 ± 1.0	103
1,600	0/10 <sup>h</sup>	20.5 ± 0.2	-	-	-

\* Significantly different ( $P \leq 0.05$ ) from the control group by Williams' or Dunnett's test.

\*\*  $P \leq 0.01$

<sup>a</sup> Number of animals surviving at 13 weeks/number initially in group

<sup>b</sup> Weights and weight changes are given as mean ± standard error. Subsequent calculations are based on animals surviving to the end of the study. No final mean body weights were calculated for groups with 100% mortality.

<sup>c</sup> Body weight taken during week 12.

<sup>d</sup> Week of death: sometime during weeks 6-13

<sup>e</sup> Week of death: 1, 1, 3, 3, 3, 3, 3, 3, 3

<sup>f</sup> Week of death: 2

<sup>g</sup> Week of death: 3, 3, 2 during weeks 6-13

<sup>h</sup> Week of death: 1, 1, 1, 1, 3, 3, 3, 3, 3

Absolute liver weights of males exposed to concentrations of 200 ppm and above and of 800 ppm females were significantly greater than those of the controls. Relative liver weights of all exposed male groups and of females exposed to 400 ppm and above were significantly greater than those of the controls (Table F3).

Microscopic lesions were observed in the forestomach, liver, and adrenal gland of mice (Table 8). Focal or multifocal pale, dark brown or black lesions were consistently observed in the mucosa of the anterior forestomach of male and female mice exposed to concentrations of 400 ppm and above and 200 ppm and above, respectively. Microscopically, these lesions corresponded to focal or multifocal

squamous epithelial hyperplasia. The average severity of these lesions was similar between exposure groups, with the exception of female mice exposed to 200 ppm in which the lesions were less prominent. Lesions varied from uniform, mildly thickened epithelium (Plates 1 and 2) to marked epithelial thickening and folding (Plates 3 and 4). Hyperplasia was associated with mild thickening of the overlying keratin layer (hyperkeratosis) and mixed inflammatory cell infiltrate in the adjacent submucosa. Focal ulcers associated with areas of epithelial hyperplasia (Plates 5 and 6) occurred in one female exposed to 200 ppm and one male and five females exposed to 1,600 ppm. A high incidence of hepatocellular cytoplasmic vacuolation occurred in the male and female mice exposed to 400 ppm and 800 ppm.

**TABLE 8**  
**Incidences of Selected Nonneoplastic Lesions in Mice in the 13-Week Inhalation Study of Acetonitrile**

	0 ppm	100 ppm	200 ppm	400 ppm	800 ppm	1,600 ppm
<b>Male</b>						
Forestomach <sup>a</sup>	10	— <sup>c</sup>	10	10	9	9 <sup>e</sup>
Hyperplasia <sup>b</sup>	0		0	3 (1.7) <sup>d</sup>	6** (2.0)	1 (2.0)
Ulcer	0		0	0	0	1 (2.0)
Liver	10	—	10	10	9	10
Cytoplasmic Vacuolation	0		0	8** (1.8)	7** (2.3)	0
<b>Female</b>						
Forestomach	10	10	10	10	10	10 <sup>e</sup>
Hyperplasia	0	0	7** (1.4)	8** (2.6)	7** (2.1)	5* (2.0)
Ulcer	0	0	1 (1.0)	0	0	5* (1.8)
Liver	10	—	10	10	10	10
Cytoplasmic Vacuolation	0		0	7** (2.4)	6** (3.0)	0
Adrenal Gland, Cortex	10	—	10	10	10	10
Fatty Degeneration	9 (1.2)		10 (1.1)	6 (1.0)	0**	0**

\* Significantly different ( $P \leq 0.05$ ) from the control group by the Fisher exact test

\*\* ( $P \leq 0.01$ )

<sup>a</sup> Number of animals with organ examined microscopically

<sup>b</sup> Number of animals with lesion

<sup>c</sup> Animals in these groups not examined microscopically

<sup>d</sup> Average severity grade of lesions in affected animals (1 = minimal; 2 = mild; 3 = moderate; 4 = marked)

<sup>e</sup> All mice died by week 4.

Vacuolation appeared to be a slight distension of preexisting cytoplasmic clear spaces and is considered to represent increased glycogen storage. The absence of such changes in hepatocytes of 1,600 ppm mice that died may be indicative of increased utilization of hepatocyte glycogen stores. Fatty degeneration was observed in the X-zone of the adrenal cortex in female control mice and female mice exposed to 200 ppm and, to a lesser extent, in female mice exposed to 400 ppm. This change, which represents normal age-related regression or involution of this zone of the adrenal cortex, was absent in females exposed to 800 or 1,600 ppm. The absence of such a change in female mice exposed to 800 or 1,600 ppm may be an indication of stress- or exposure-related

acceleration of this normal process. Additional alterations that occurred only in mice that died during the study, including lymphoid depletion and lymphocytolysis in the thymus, spleen, and bone marrow, and pulmonary congestion, were considered to be nonspecific changes typically observed in moribund animals.

*Dose Selection Rationale:* Based on reduced survival and gross and histopathologic lesions in 400, 800, and 1,600 ppm males and females in the 13-week study, acetonitrile exposure concentrations selected for the 2-year inhalation study in mice were 50, 100, and 200 ppm.

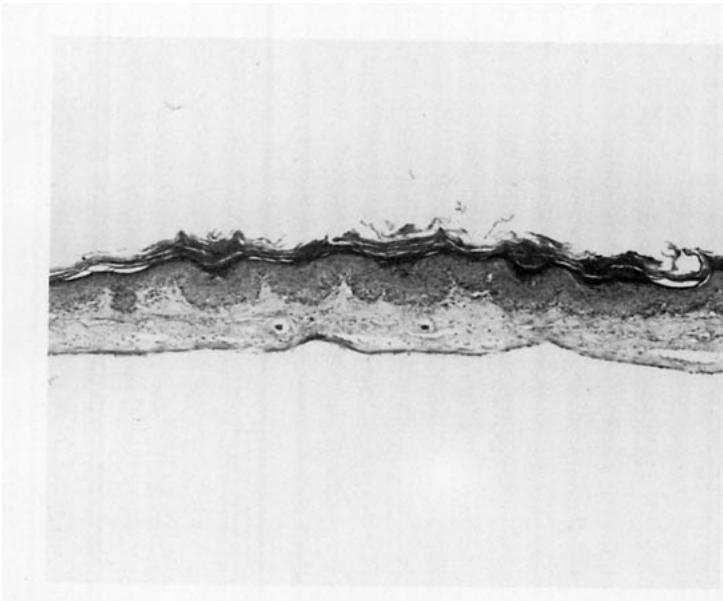

**PLATE 1**

Mild focal hyperplasia of the squamous epithelium in the forestomach of a female B6C3F<sub>1</sub> mouse exposed to 400 ppm acetonitrile by inhalation for 13 weeks. H&E; 45.5×

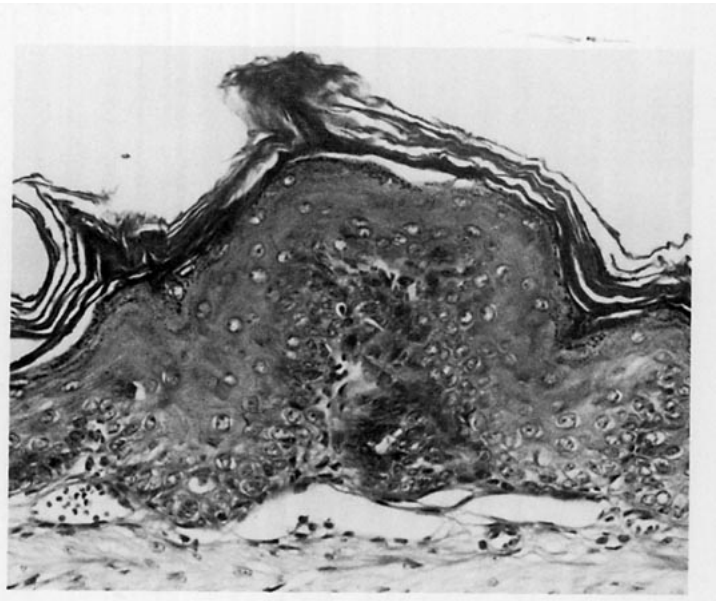

**PLATE 2**

Higher magnification of Plate 1. Note orderly maturation of the thickened epithelium and mildly thickened keratin layer (hyperkeratosis). H&E; 87.5×



**PLATE 3**

Marked focal hyperplasia of the squamous epithelium in the forestomach of a female B6C3F<sub>1</sub> mouse exposed to 800 ppm acetonitrile by inhalation for 13 weeks. Note papillary-like folding of the epithelium and thickened keratin layer. H&E; 56×

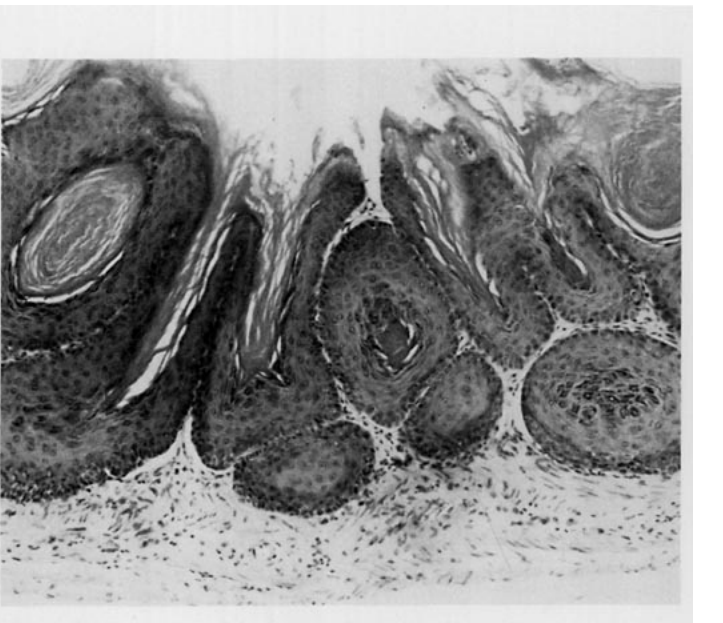

**PLATE 4**

Higher magnification of Plate 3. H&E; 87.5×

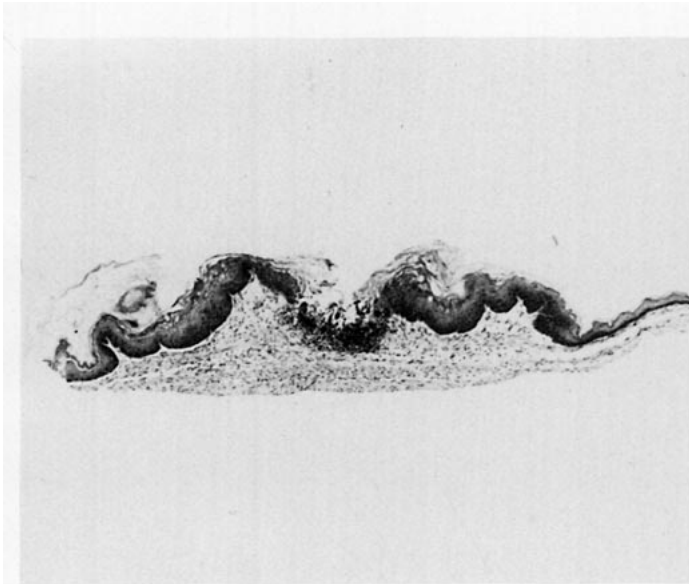

**PLATE 5**

Ulcer within focal hyperplasia of the squamous epithelium in the forestomach of a male B6C3F<sub>1</sub> mouse exposed to 1,600 ppm acetonitrile by inhalation for 13 weeks. H&E; 35×

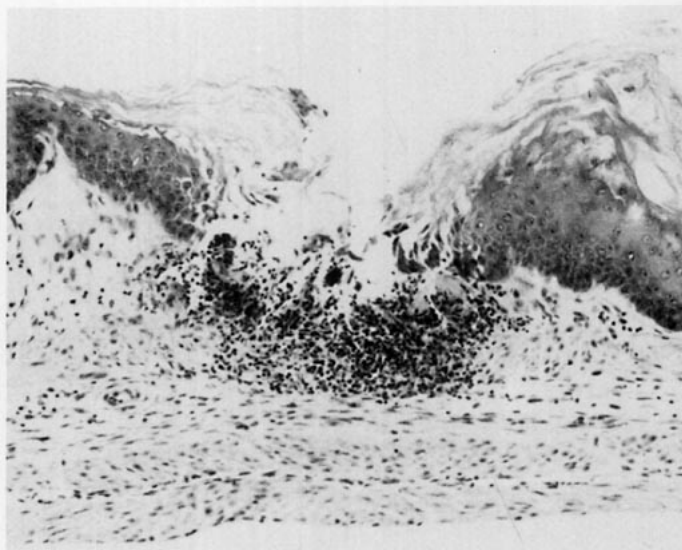

**PLATE 6**

Higher magnification of Plate 5. Note focal loss of the epithelium and inflammatory cell infiltrates (neutrophils) in the adjacent submucosal stroma. The keratin layer on the surface of the adjacent hyperplastic epithelium is slightly thickened. H&E; 115.5×

## 2-YEAR STUDY

### Survival

Estimates of 2-year survival probabilities for male and female mice are shown in Table 9 and in the Kaplan-Meier survival curves in Figure 3. Survival of exposed males and females was generally similar to that of the controls. Survival of 200 ppm male mice was significantly greater than that of controls.

### Body Weights and Clinical Findings

Exposure to acetonitrile by inhalation for up to 2 years had no effect on body weight gains or final mean body weights of male and female mice (Figure 4, Tables 10 and 11). Clinical observations were not considered related to exposure to acetonitrile.

**TABLE 9**  
**Survival of Mice in the 2-Year Inhalation Study of Acetonitrile**

	0 ppm	50 ppm	100 ppm	200 ppm
<b>Male</b>				
Animals initially in study	60	60	60	60
15-Month interim evaluation <sup>a</sup>	10	10	10	10
Natural deaths	5	4	2	1
Moribund	13	14	16	6
Animals surviving to study termination	32	32	32	43
Percent probability of survival at end of study <sup>b</sup>	64	64	64	86
Mean survival (days) <sup>c</sup>	651	653	653	677
Survival analysis <sup>d</sup>	P=0.013N	P=1.000N	P=1.000N	P=0.017N
<b>Female</b>				
Animals initially in study	60	60	60	60
15-Month interim evaluation <sup>a</sup>	10	10	10	10
Accidental death <sup>a</sup>	1	0	0	0
Natural deaths	6	5	8	5
Moribund	15	12	13	13
Animals surviving to study termination	28	33 <sup>e</sup>	29	32
Percent probability of survival at end of study	58	67	58	65
Mean survival (days)	642	655	665	629
Survival analysis	P=0.905N	P=0.554N	P=0.918N	P=0.822N

<sup>a</sup> Censored from survival analyses

<sup>b</sup> Kaplan-Meier determinations based on the number of animals alive on the first day of terminal sacrifice

<sup>c</sup> Mean of all deaths (uncensored, censored, and terminal sacrifice)

<sup>d</sup> The result of the life table trend test (Tarone, 1975) is in the control column, and the results of the life table pairwise comparisons (Cox, 1972) with the controls are in the exposed columns. A negative trend or lower mortality in an exposure group is indicated by N.

<sup>e</sup> Includes one animal that died the last week of the study

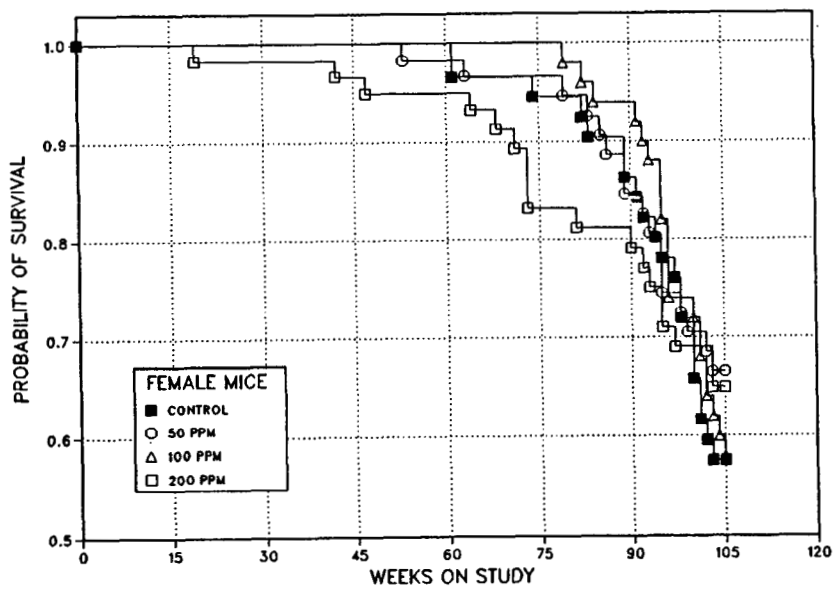
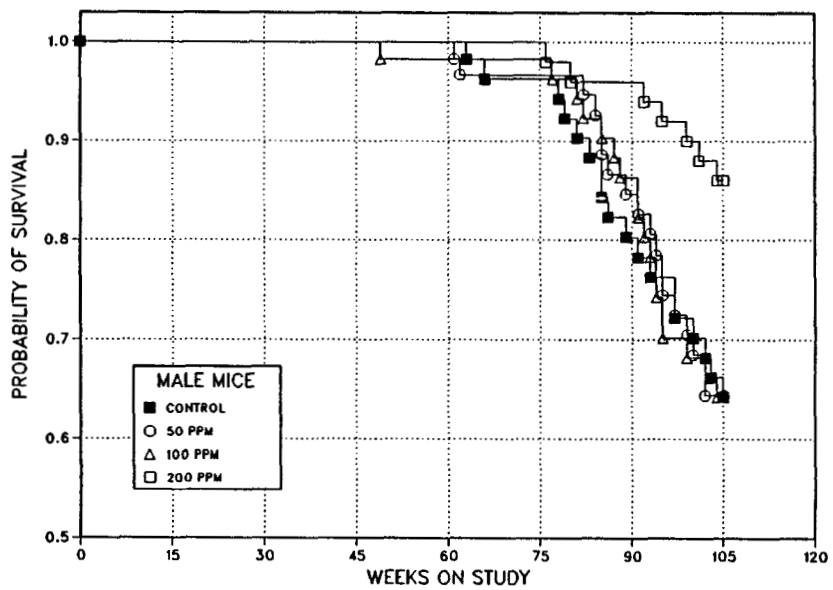

**FIGURE 3**  
**Kaplan-Meier Survival Curves for Mice Administered Acetonitrile**  
**by Inhalation for 2 Years**



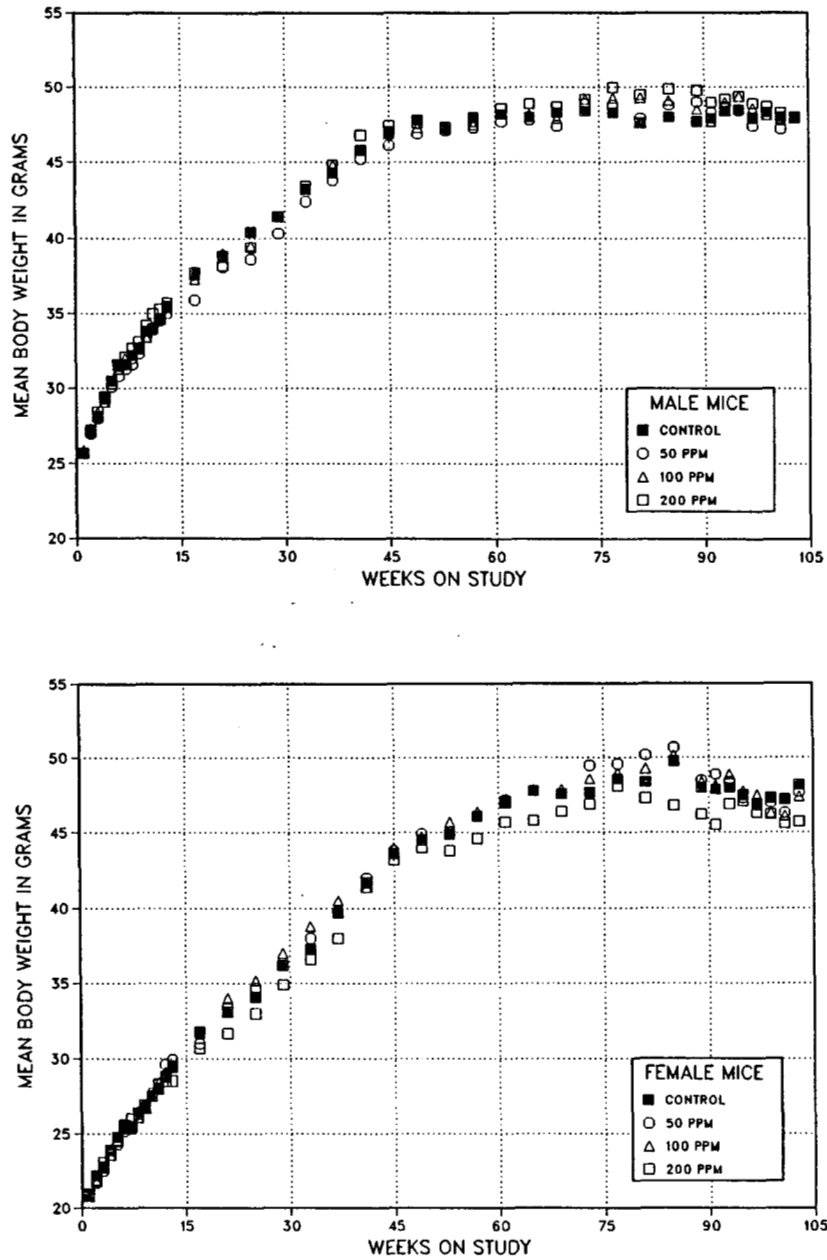

FIGURE 4  
Growth Curves for Mice Administered Acetonitrile by Inhalation for 2 Years

**TABLE 10**  
**Mean Body Weights and Survival of Male Mice in the 2-Year Inhalation Study of Acetonitrile**

Weeks on Study	0 ppm		50 ppm			100 ppm			200 ppm		
	Av. Wt. (g)	No. of Survivors	Av. Wt. (g)	Wt. (% of controls)	No. of Survivors	Av. Wt. (g)	Wt. (% of controls)	No. of Survivors	Av. Wt. (g)	Wt. (% of controls)	No. of Survivors
1	25.0	60	24.9	100	60	25.0	100	60	24.6	98	60
2	27.2	60	27.0	99	60	27.3	100	60	27.1	100	60
3	28.1	60	28.0	100	60	28.4	101	60	28.4	101	60
4	29.3	60	29.1	99	60	29.1	99	60	29.4	100	60
5	30.5	60	30.1	99	60	30.3	99	60	30.5	100	60
6	31.5	60	30.8	98	60	31.3	99	60	31.6	100	60
7	31.7	60	31.3	99	60	32.0	101	60	32.1	101	60
8	32.2	60	31.6	98	60	32.0	99	60	32.7	102	60
9	32.7	60	32.3	99	60	32.6	100	60	33.1	101	60
10	33.8	60	33.4	99	60	33.4	99	60	34.2	101	60
11	34.0	60	33.9	100	60	34.1	100	60	35.0	103	60
12	34.6	60	34.5	100	60	34.7	100	60	35.3	102	60
13	35.5	60	35.0	99	60	35.4	100	60	35.7	101	60
17	37.7	60	35.9	95	60	37.3	99	60	37.6	100	60
21	38.8	60	38.1	98	60	39.0	101	60	38.2	99	60
25	40.4	60	38.6	96	60	39.5	98	60	39.4	98	60
29	41.4	60	40.3	97	60	41.4	100	60	41.4	100	60
33	43.2	60	42.4	98	60	43.2	100	60	43.4	101	60
37	44.3	60	43.8	99	60	44.8	101	60	44.8	101	60
41	45.8	60	45.2	99	60	45.8	100	60	46.8	102	60
45	47.0	60	46.1	98	60	46.9	100	60	47.4	101	60
49	47.8	60	46.9	98	60	47.3	99	59	47.6	100	60
53	47.3	60	47.1	100	60	47.2	100	59	47.3	100	60
57	48.0	60	47.3	99	60	47.5	99	59	47.7	99	60
61	48.2	60	47.7	99	59	48.2	100	59	48.6	101	60
65	48.0	59	47.8	100	58	48.2	100	59	48.9	102	60
69 <sup>a</sup>	48.3	48	47.4	98	48	47.9	99	49	48.7	101	50
73	48.4	48	48.9	101	48	49.2	102	49	49.3	102	50
77	48.3	48	48.8	101	48	49.3	102	48	50.0	104	49
81	47.6	45	47.9	101	48	49.3	104	48	49.5	104	48
85	48.1	44	48.8	102	46	49.1	102	46	49.9	104	48
89	47.7	41	49.0	103	43	48.5	102	43	49.8	104	48
91	47.9	40	48.3	101	41	47.8	100	42	49.0	102	48
93	48.4	38	48.7	101	40	49.0	101	39	49.2	102	47
95	48.5	38	48.4	100	37	49.4	102	36	49.4	102	47
97	47.9	36 <sup>b</sup>	47.4	99	36	48.6	102	35	48.9	102	46
99	48.3	36	48.1	100	35	48.1	100	34	48.7	101	45
101	48.0	35	47.2	98	34	47.8	100	34	48.3	101	44
103	48.0	33	48.0	100	32	47.9	100	33	47.9	100	44
<b>Mean for weeks</b>											
1-13	31.2		30.9	99		31.2	100		31.5	101	
14-52	42.9		41.9	98		42.8	100		43.0	100	
53-103	48.1		48.1	100		48.4	101		48.9	102	

<sup>a</sup> Interim evaluation occurred during week 66.

<sup>b</sup> The number of animals weighed for this week is fewer than the number of animals surviving.

**TABLE 11**  
**Mean Body Weights and Survival of Female Mice in the 2-Year Inhalation Study of Acetonitrile**

Weeks on Study	0 ppm		50 ppm			100 ppm			200 ppm		
	Av. Wt. (g)	No. of Survivors	Av. Wt. (g)	Wt. (% of controls)	No. of Survivors	Av. Wt. (g)	Wt. (% of controls)	No. of Survivors	Av. Wt. (g)	Wt. (% of controls)	No. of Survivors
1	20.3	60	20.0	99	60	20.0	99	60	19.8	98	60
2	22.2	59	21.8	98	60	21.8	98	60	21.9	99	60
3	22.8	59	22.5	99	60	22.7	100	60	23.1	101	60
4	23.9	59	23.6	99	60	23.6	99	60	23.6	99	60
5	24.8	59	24.3	98	60	24.6	99	60	24.5	99	60
6	25.5	59	25.2	99	60	25.4	100	60	25.6	100	60
7	25.5	59	25.4	100	60	25.5	100	60	26.0	102	60
8	26.4	59	26.3	100	60	26.1	99	60	26.3	100	60
9	26.7	59	26.8	100	60	26.9	101	60	26.9	101	60
10	27.5	59	27.7	101	60	27.6	100	60	27.5	100	60
11	28.0	59	28.3	101	60	28.4	101	60	28.3	101	60
12	28.8	59	29.6	103	60	29.1	101	60	28.5	99	60
13	29.5	59	29.9	101	60	29.4	100	60	28.5	97	60
17	31.8	59	31.0	98	60	31.7	100	60	30.7	97	60
21	33.1	59	33.4	101	60	34.0	103	60	31.7	96	59
25	34.1	59	34.7	102	60	35.2	103	60	33.0	97	59
29	36.2	59	36.2	100	60	37.0	102	60	34.9	96	59
33	37.3	59	38.0	102	60	38.8	104	60	36.6	98	59
37	39.7	59	39.8	100	60	40.5	102	60	38.0	96	59
41	41.7	59	42.0	101	60	41.4	99	60	41.4	99	59
45	43.6	59	43.8	101	60	44.0	101	60	43.2	99	58
49	44.5	59	44.9	101	60	44.7	100	60	44.0	99	57
53	44.9	59	44.9	100	59	45.7	102	60	43.8	98	57
57	46.1	59	46.1	100	59	46.4	101	60	44.6	97	57
61	47.1	57	47.2	100	59	47.0	100	60	45.7	97	57
65	47.8	57	47.8	100	58	47.9	100	60	45.8	96	56
69 <sup>a</sup>	47.6	47	47.6	100	48	47.9	101	50	46.4	98	45
73	47.7	47	49.5	104	48	48.6	102	50	46.9	98	41
77	48.6	46	49.6	102	48	49.0	101	50	48.1	99	41
81	48.4	46	50.2	104	47	49.3	102	49	47.3	98	40
85	49.8	44	50.7	102	46	50.2	101	47	46.8	94	40
89	48.0	43	48.5	101	43	48.4	101	47	46.2	96	40
91	47.9	41	48.9	102	42	48.2	101	46	45.5	95	39
93	48.0	40	48.4	101	40	48.9	102	44	46.9	98	37
95	47.5	38	47.3	100	38	47.8	101	43	47.1	99	35
97	46.9	37	46.8	100	37	47.5	101	37	46.3	99	34
99	47.3	35	47.0	99	35	46.3	98	37	46.2	98	34
101	47.2	30	46.3	98	35	46.1	98	35	45.6	97	34
103	48.2	28	47.7	99	33	47.4	98	31	45.7	95	32
<b>Mean for weeks</b>											
1-13	25.5		25.5	100		25.5	100		25.4	100	
14-52	38.0		38.2	101		38.6	102		37.1	98	
53-103	47.6		47.9	101		47.8	100		46.2	97	

<sup>a</sup> Interim evaluation occurred during week 66.

### Pathology and Statistical Analyses

This section describes the statistically significant or biologically noteworthy changes in the incidences of nonneoplastic lesions of the forestomach, and neoplasms of the lung, liver, and forestomach. Summaries of the incidences of neoplasms and nonneoplastic lesions, individual animal tumor diagnoses, statistical analyses of primary neoplasms that occurred with an incidence of at least 5% in at

least one animal group, and historical incidences for the neoplasms mentioned in this section are presented in Appendix C for male mice and Appendix D for female mice.

*Lung:* There was an increased incidence of alveolar/bronchiolar adenoma in exposed male mice. The incidence was significantly increased in 200 ppm males (Tables 12 and C3) and was at the upper limit

**TABLE 12**  
**Incidences of Neoplasms and Nonneoplastic Lesions of the Lung of Mice**  
**in the 2-Year Inhalation Study of Acetonitrile**

Dose	0 ppm	50 ppm	100 ppm	200 ppm
<b>Male</b>				
<b>15-Month Interim Evaluation</b>				
Number Examined	10	10	10	10
Alveolar/bronchiolar Adenoma <sup>a</sup>	1	3	2	3
Alveolar/bronchiolar Carcinoma	2	1	0	0
<b>2-Year Study</b>				
<b>Lung</b>	50	50	48	50
Alveolar Epithelium, Hyperplasia	4 (1.5) <sup>b</sup>	5 (1.2)	3 (1.3)	2 (1.5)
Alveolar/bronchiolar Adenoma <sup>c</sup>				
Overall rate <sup>d</sup>	6/50 (12%)	9/50 (18%)	8/48 (17%)	18/50 (36%)
Adjusted rate <sup>e</sup>	18.8%	28.1%	24.2%	38.2%
Terminal rate <sup>f</sup>	6/32 (19%)	9/32 (28%)	7/32 (22%)	14/43 (33%)
First incidence (days)	733 (T)	733 (T)	727	554
Logistic regression test <sup>g</sup>	P=0.010	P=0.279	P=0.375	P=0.011
Alveolar/bronchiolar Carcinoma <sup>h</sup>				
Overall rate	4/50 (8%)	6/50 (12%)	6/48 (13%)	4/50 (8%)
Adjusted rate	12.1%	16.5%	16.4%	9.3%
Terminal rate	3/32 (9%)	4/32 (13%)	3/32 (9%)	4/43 (9%)
First incidence (days)	729	583	607	733 (T)
Logistic regression test	P=0.450N	P=0.374	P=0.367	P=0.491N
Alveolar/bronchiolar Adenoma or Carcinoma <sup>i</sup>				
Overall rate	10/50 (20%)	14/50 (28%)	14/48 (29%)	21/50 (42%)
Adjusted rate	30.3%	40.3%	38.5%	44.6%
Terminal rate	9/32 (28%)	12/32 (38%)	10/32 (31%)	17/43 (40%)
First incidence (days)	729	583	607	554
Logistic regression test	P=0.038	P=0.239	P=0.234	P=0.042

(continued)

**TABLE 12**  
**Incidences of Neoplasms and Nonneoplastic Lesions of the Lung of Mice**  
**in the 2-Year Inhalation Study of Acetonitrile (continued)**

Dose	0 ppm	50 ppm	100 ppm	200 ppm
<b>Female</b>				
<b>15-Month Interim Evaluation</b>				
Number Examined	10	10	10	10
Adenoma	0	0	2	1
<b>2-Year Study</b>				
Number Examined	49	50	50	49
Alveolar Epithelium, Hyperplasia	3 (1.0)	4 (1.8)	2 (1.5)	1 (2.0)
Alveolar/bronchiolar Adenoma <sup>j</sup>				
Overall rate	7/49 (14%)	2/50 (4%)	2/50 (4%)	0/49 (0%)
Adjusted rate	25.0%	6.1%	6.9%	0.0%
Terminal rate	7/28 (25%)	2/33 (6%)	2/29 (7%)	0/32 (0%)
First incidence (days)	735 (T)	735 (T)	735 (T)	- <sup>k</sup>
Logistic regression test	P=0.003N	P=0.044N	P=0.067N	P=0.005N
Alveolar/bronchiolar Carcinoma <sup>l</sup>				
Overall rate	1/49 (2%)	1/50 (2%)	0/50 (0%)	1/49 (2%)
Adjusted rate	3.1%	3.0%	0.0%	3.1%
Terminal rate	0/28 (0%)	1/33 (3%)	0/29 (0%)	1/32 (3%)
First incidence (days)	706	735 (T)	-	735 (T)
Logistic regression test	P=0.621N	P=0.753N	P=0.491N	P=0.758
Alveolar/bronchiolar Adenoma or Carcinoma <sup>m</sup>				
Overall rate	8/49 (16%)	3/50 (6%)	2/50 (4%)	1/49 (2%)
Adjusted rate	27.3%	9.1%	6.9%	3.1%
Terminal rate	7/28 (25%)	3/33 (9%)	2/29 (7%)	1/32 (3%)
First incidence (days)	706	735 (T)	735 (T)	735 (T)
Logistic regression test	P=0.007N	P=0.065N	P=0.032N	P=0.012N

(T)Terminal sacrifice

<sup>a</sup> Number of animals with lesion

<sup>b</sup> Average severity of lesions in affected mice: 1 = minimal; 2 = mild; 3 = moderate; 4 = marked

<sup>c</sup> Historical incidence for 2-year inhalation studies with control groups (mean  $\pm$  standard deviation): 113/673 (16.8%  $\pm$  7.6%); range, 6%-36%

<sup>d</sup> Number of animals with neoplasm per number of animals with lung examined microscopically

<sup>e</sup> Kaplan-Meier estimated neoplasm incidence at the end of the study after adjustment for intercurrent mortality

<sup>f</sup> Observed incidence in animals surviving until the end of the study

<sup>g</sup> In the control column are the P values associated with the trend test. In the exposed group columns are the P values corresponding to the pairwise comparisons between the controls and that exposed group. The logistic regression test regards these lesions as nonfatal. A negative trend or lower incidence in an exposure group is indicated by N.

<sup>h</sup> Historical incidence: 45/673 (6.7%  $\pm$  5.6%); range, 0%-16%

<sup>i</sup> Historical incidence: 150/673 (22.3%  $\pm$  9.0%); range, 10%-42%

<sup>j</sup> Historical incidence: 40/659 (6.1%  $\pm$  2.8%); range, 0%-10%

<sup>k</sup> Not applicable; no neoplasms in animal group

<sup>l</sup> Historical incidence: 19/659 (2.9%  $\pm$  2.5%); range, 0%-6%

<sup>m</sup> Historical incidence: 58/659 (8.8%  $\pm$  3.5%); range, 0%-15%

of the range of historical controls (Tables 12 and C4a). The incidences of alveolar/bronchiolar adenoma or carcinoma (combined) were similarly increased in exposed males. In contrast, the incidences of alveolar/bronchiolar adenoma and adenoma or carcinoma (combined) were inversely related to exposure concentration in females (Tables 12 and D3); the incidences of these neoplasms in female controls were greater than the upper range of historical controls (Tables 12 and D4a).

*Liver:* At 2 years, the incidence of hepatocellular carcinoma in 100 ppm males was significantly greater than that in the controls. The incidence of hepatocellular adenoma or carcinoma (combined) was significantly increased in 100 ppm males and exceeded the range of historical controls (Tables 13, C3, and C4b). In exposed females, the incidences of hepatocellular adenoma and hepatocellular adenoma or carcinoma (combined) were similar to those of controls (Tables 13 and D3).

**TABLE 13**  
**Incidences of Neoplasms of the Liver of Mice in the 2-Year Inhalation Study of Acetonitrile**

Dose	0 ppm	50 ppm	100 ppm	200 ppm
<b>Male</b>				
<b>15-Month Interim Evaluation</b>				
Number Examined	10	10	10	10
Hepatocellular Adenoma <sup>a</sup>	2	1	2	1
Hepatocellular Carcinoma	1	3	0	0
<b>2-Year Study</b>				
<b>Hepatocellular Adenoma<sup>b</sup></b>				
Overall rate <sup>c</sup>	13/50 (26%)	12/50 (24%)	18/49 (37%)	10/50 (20%)
Adjusted rate <sup>d</sup>	35.0%	31.7%	49.1%	22.2%
Terminal rate <sup>e</sup>	9/32 (28%)	8/32 (25%)	14/32 (44%)	8/43 (19%)
First incidence (days)	563	434	595	701
Logistic regression test <sup>f</sup>	P=0.293N	P=0.500N	P=0.189	P=0.249N
<b>Hepatocellular Carcinoma<sup>g</sup></b>				
Overall rate	7/50 (14%)	11/50 (22%)	13/49 (27%)	7/50 (14%)
Adjusted rate	15.3%	24.6%	30.3%	15.0%
Terminal rate	1/32 (3%)	1/32 (3%)	4/32 (13%)	4/43 (9%)
First incidence (days)	437	571	342	532
Logistic regression test	P=0.163	P=0.128	P=0.038	P=0.208
<b>Hepatocellular Adenoma or Carcinoma<sup>h</sup></b>				
Overall rate	19/50 (38%)	21/50 (42%)	30/49 (61%)	15/50 (30%)
Adjusted rate	44.5%	46.7%	67.7%	31.8%
Terminal rate	10/32 (31%)	9/32 (28%)	18/32 (56%)	11/43 (26%)
First incidence (days)	437	434	342	532
Logistic regression test	P=0.437N	P=0.394	P=0.013	P=0.454N

(continued)

**TABLE 13**  
**Incidences of Neoplasms of the Liver of Mice in the 2-Year Inhalation Study of Acetonitrile** (continued)

Dose	0 ppm	50 ppm	100 ppm	200 ppm
<b>Female</b>				
<b>15-Month Interim Evaluation</b>				
Number Examined	10	10	10	10
Hepatocellular Adenoma	0	2	1	0
<b>2-Year Study</b>				
Hepatocellular Adenoma <sup>i</sup>				
Overall rate	4/49 (8%)	8/50 (16%)	8/50 (16%)	6/49 (12%)
Adjusted rate	12.0%	22.4%	25.6%	18.8%
Terminal rate	2/28 (7%)	6/33 (18%)	6/29 (21%)	6/32 (19%)
First incidence (days)	569	664	708	735 (T)
Logistic regression test	P=0.390	P=0.191	P=0.211	P=0.346
Hepatocellular Carcinoma <sup>j</sup>				
Overall rate	7/49 (14%)	6/50 (12%)	6/50 (12%)	5/49 (10%)
Adjusted rate	23.1%	15.8%	16.4%	13.6%
Terminal rate	5/28 (18%)	3/33 (9%)	2/29 (7%)	3/32 (9%)
First incidence (days)	706	595	570	510
Logistic regression test	P=0.340N	P=0.475N	P=0.457N	P=0.399N
Hepatocellular Adenoma or Carcinoma <sup>k</sup>				
Overall rate	9/49 (18%)	13/50 (26%)	13/50 (26%)	10/49 (20%)
Adjusted rate	28.0%	33.5%	36.9%	28.5%
Terminal rate	6/28 (21%)	8/33 (24%)	8/29 (28%)	8/32 (25%)
First incidence (days)	569	595	570	510
Logistic regression test	P=0.489	P=0.257	P=0.284	P=0.466

(T)Terminal sacrifice

<sup>a</sup> Number of animals with neoplasm per number of animals with liver examined microscopically

<sup>b</sup> Historical incidence for 2-year inhalation studies with control groups (mean ± standard deviation): 120/673 (17.8% ± 11.0%); range, 4%-38%

<sup>c</sup> Number of animals with neoplasm per number of animals examined microscopically

<sup>d</sup> Kaplan-Meier estimated neoplasm incidence at the end of the study after adjustment for intercurrent mortality

<sup>e</sup> Observed incidence in animals surviving until the end of the study

<sup>f</sup> In the control column are the P values associated with the trend test. In the exposed group columns are the P values corresponding to the pairwise comparisons between the controls and that exposed group. The logistic regression test regards these lesions as nonfatal. A negative trend or lower incidence in an exposure group is indicated by N.

<sup>g</sup> Historical incidence: 136/673 (20.2% ± 5.9%); range, 9%-29%

<sup>h</sup> Historical incidence: 241/673 (35.8% ± 12.1%); range, 11%-56%

<sup>i</sup> Historical incidence: 56/657 (8.5% ± 6.2%); range, 0%-22%

<sup>j</sup> Historical incidence: 57/657 (8.7% ± 4.8%); range, 0%-16%

<sup>k</sup> Historical incidence: 111/657 (16.9% ± 8.7%); range, 3%-31%

**Forestomach:** The incidence of squamous cell papilloma of the forestomach was marginally increased in male and female mice exposed to 200 ppm (Tables 14, C1, and D1) and these rates equaled the highest values observed in the historical controls (Tables 14, C4c, and D4c). At 15 months, the incidence of squamous hyperplasia of the forestomach in males and females exposed to 50 or 200 ppm was greater than that in the controls; however, the increase was only significant in 200 ppm females. At 2 years, the incidences increased with increasing exposure concentration in exposed groups; the increases were significant in 200 ppm males and 100 and 200 ppm females (Tables 14, C5, and D5).

Hyperplasia was generally focal and of minimal to marked severity. Minimal lesions were characterized by slight thickening of the epithelium, frequently accompanied by slight thickening of the overlying keratin layer and increased numbers of basal cells. Increasing severity was accompanied by progressive epithelial thickening and folding. In markedly severe lesions, folds of thickened epithelium projected above the mucosal surface. Focal ulcers and suppurative inflammation occurred in some severe lesions. Papillomas were exophytic, pedunculated, and frond-like masses composed of hyperplastic, sometimes hyperkeratotic, squamous epithelium supported by a branched core of fibrous connective tissue stroma.

**TABLE 14**  
**Incidences of Neoplasms and Nonneoplastic Lesions of the Forestomach of Mice**  
**in the 2-Year Inhalation Study of Acetonitrile**

Dose	0 ppm	50 ppm	100 ppm	200 ppm
<b>Male</b>				
<b>15-Month Interim Evaluation</b>				
Number Examined	10	10	10	10
Squamous Hyperplasia <sup>a</sup>	0	2	0	3
<b>2-Year Study</b>				
Number Examined	49	50	48	50
Squamous Hyperplasia	3 (2.3) <sup>b</sup>	3 (3.3)	6 (2.5)	12* (1.9)
Squamous Cell Papilloma <sup>c</sup>	0	0	1	2
<b>Female</b>				
<b>15-Month Interim Evaluation</b>				
Number Examined	10	10	10	10
Squamous Hyperplasia	0	1	0	6**
<b>2-Year Study</b>				
Number Examined	49	50	50	48
Squamous Hyperplasia	2 (3.5)	7 (2.6)	9** (2.3)	19** (2.6)
Squamous Cell Papilloma <sup>d</sup>	1	0	1	3

\* Significantly different ( $P \leq 0.05$ ) from the control group by the logistic regression test

\*\* Significantly different ( $P \leq 0.01$ ) from the control group by the Fisher exact test (15-month interim evaluation) or the logistic regression test (2-year study)

<sup>a</sup> Number of animals with lesion

<sup>b</sup> Average severity grade of lesions in affected animals (1 = minimal; 2 = mild; 3 = moderate; 4 = marked)

<sup>c</sup> Historical incidence for 2-year inhalation studies with control groups (mean  $\pm$  standard deviation): 5/676 (0.7%  $\pm$  1.3%); range, 0%-4%

<sup>d</sup> Historical incidence: 8/661 (1.2%  $\pm$  2.0%); range, 0%-6%



## GENETIC TOXICOLOGY

Acetonitrile (100 to 10,000  $\mu\text{g}/\text{plate}$ ) was tested in two laboratories for induction of mutations in *Salmonella typhimurium* strains TA97, TA98, TA100, TA1535, and TA1537, with and without Aroclor 1254-induced rat and hamster liver S9; no mutagenic activity was observed in any strain/activation combination (Mortelmans *et al.*, 1986; Table E1). In cytogenetic tests with cultured Chinese hamster ovary cells, acetonitrile was a weak inducer of sister chromatid exchanges in the absence of S9 (Galloway *et al.*, 1987; Table E2) and chromosomal aberrations in the presence of S9 (Galloway *et al.*, 1987; Table E3); for both endpoints, the increases were noted at the highest dose tested (5,000  $\mu\text{g}/\text{mL}$ ). Despite the increase in aberrations noted at the high dose in the trial conducted with S9, the trend test was not significant ( $P > 0.015$ ) and the trial results were concluded to be equivocal.

The ability of acetonitrile to induce chromosomal damage in mammalian cells *in vivo* was assessed by determining the frequency of micronucleated normochromatic erythrocytes in peripheral blood samples of male and female mice treated for 13 weeks with acetonitrile (100 to 800 ppm) by inhalation (Table E4). Results with female mice were negative but in males, a small but significant increase in micronucleated normochromatic erythrocytes was observed in the 400 ppm group.

In conclusion, acetonitrile did not induce gene mutations in bacteria and showed only weak clastogenic activity in cultured mammalian cells; *in vivo*, evidence for chromosomal damage in male mice was observed in the form of increased frequencies of micronucleated normochromatic erythrocytes.



## DISCUSSION AND CONCLUSIONS

The results of the 13-week inhalation studies of acetonitrile are consistent with those expected based on the toxicity information in the literature. The dose response for acetonitrile toxicity is quite steep, with little evidence of adverse effects in animals exposed to concentrations lower than those that resulted in death, or in survivors in exposure groups in which some animals died.

In the 13-week study, several male and female rats exposed to 1,600 ppm and one male exposed to 800 ppm died. The deaths occurred primarily during the first week of exposure, suggesting either adaptation of the remaining animals to continuing exposure or a range of susceptibility to acetonitrile-induced lethality. Body weight gains were not affected at exposure concentrations below 1,600 ppm, nor were there significant exposure-related clinical findings. Rats that died during the study showed a spectrum of lesions consistent with previous descriptions of acetonitrile-induced toxicity, in addition to lesions typically encountered in early death animals in other NTP studies. Pulmonary lesions of congestion, edema, and hemorrhage in the alveoli and evidence of hemorrhage in the brain are consistent with prior reports (Pozzani *et al.*, 1959a; Haguenoer *et al.*, 1975b) and have been attributed to cyanide-induced anoxia. Atrophy and cellular depletion of lymphoid tissues and corpora lutea of the ovary are frequently seen in debilitated animals and occurred in the current study only in those rats that died early. There are no specific gross or histopathologic lesions produced in acute cyanide poisoning, but tissues often show congestion with hemorrhage in various organs, and gastric erosions have been reported (Way, 1981; Ballantyne, 1983). Surviving female rats exposed to 1,600 ppm did show increases in a number of organ weights, suggesting possible congestion and edema. A mild nonresponsive anemia occurred in males exposed to 1,600 ppm and females exposed to 800 or 1,600 ppm. This would suggest that the survivors were affected by acetonitrile exposure at these concentrations.

Mice appeared somewhat more susceptible to acetonitrile-induced mortality than rats. Mortality in the 13-week mouse study was complete at 1,600 ppm, and deaths of females extended down to the 400 ppm group. As with the rats, body weight gains of survivors were not markedly affected and specific clinical findings were not noted. In contrast to the rats, lesions other than lymphoid depletion were observed in mice, occurring primarily among those mice surviving to the end of the study. These lesions were largely absent in mice dying during the first 3 weeks. In mice, acetonitrile-related toxicity was observed in the adrenal gland, the liver, and the forestomach. The most significant lesions were hyperplasia with occasional inflammation and ulceration in the forestomach. The character of the lesion was similar to forestomach lesions occasionally seen in mice in other NTP inhalation studies (Melnick *et al.*, 1990), suggesting that the effect may not be specifically related to acetonitrile exposure but rather to some other factor associated with the conditions of exposure. However, gastric erosions have been observed with cyanide intoxication, as noted above, and may represent a true effect of acetonitrile exposure.

The primary factor influencing the selection of exposure concentrations for the 2-year studies was the mortality observed in the 13-week studies. The greater number of deaths of mice than rats at 400 and 800 ppm, coupled with the forestomach effects in mice, led to the selection of 200 ppm as the highest exposure concentration for mice and 400 ppm for rats. Thus, the high exposure concentrations selected were within a factor of two of those that were lethal in the 13-week studies.

In the 2-year rat study, neither body weight gains nor survival were affected by acetonitrile exposure. This agrees with previous data indicating that acetonitrile does not accumulate in the body (Haguenoer *et al.*, 1975a,b) and suggests that there is no significant age-related decline in acetonitrile metabolism. At 15 months, minimal anemia was noted in females

exposed to 400 ppm. However, there was no evidence of significant exposure-related nonneoplastic lesions in male or female rats at 15 months or 2 years.

The only partially positive neoplastic finding in rats was a marginal increase in the incidence of hepatocellular adenoma or carcinoma (combined) in male rats exposed to 400 ppm. Statistical significance was achieved ( $P=0.045$ ) for a dose-related trend, but pairwise comparisons of the exposed group incidences versus the control incidence were not significant. In 400 ppm males, the incidence of hepatocellular adenoma or carcinoma (combined) (5/48, 10%) is higher than the historical control incidence of 3.8% for inhalation studies and slightly higher than the upper range of incidences observed in any one control group (8%). A 10% incidence has been noted in four previous control groups in dosed feed studies (NTP, 1989, 1991, 1993, 1994b). The incidences of basophilic foci were also significantly increased in the 200 and 400 ppm exposure groups, and the incidences of eosinophilic and mixed cell foci were marginally increased in the 400 ppm group. While the specific relationship between various hepatocellular foci and neoplasia is not clearly understood, these foci did not appear atypical, as with those considered more directly involved in the carcinogenic process (Harada *et al.*, 1989). However, evidence of chemical-related increased incidences of hepatocellular foci does provide support for an acetonitrile-related effect on the liver and suggests that a liver tumor response is biologically plausible. Overall, a causal relationship between acetonitrile exposure and liver neoplasia in male rats remains uncertain.

In the 2-year study in mice, adverse effects on body weight gains and survival were not observed and, in fact, survival of male mice exposed to 200 ppm was significantly greater than that of the controls. Effects on the forestomach were again noted in exposed mice, with significant increases in the incidences of squamous hyperplasia in males exposed to 200 ppm and in females exposed to 100 or 200 ppm. A few squamous cell papillomas were noted in mice exposed to 100 or 200 ppm, and one occurred in a control female. The incidences of this benign tumor were not statistically significant in males or females and were within the ranges of historical controls. Thus, these findings establish an effect of prolonged acetonitrile exposure on the forestomach of mice, but the

magnitude of the neoplastic findings is insufficient to attribute to the chemical with any confidence.

The incidence of alveolar/bronchiolar adenoma in male mice exposed to 200 ppm was significantly greater than that in the controls. Conversely, the incidence of alveolar/bronchiolar adenoma decreased with a significant dose-related trend in females. Proliferative lesions of the alveolar/bronchiolar region were present as a continuum, with the distinction between hyperplasia, adenoma, and carcinoma based on the size and morphologic characteristics of the lesion. Thus, a true chemical-related increased incidence in this neoplasm type would be expected to manifest as an increase in proliferative lesions of all three stages, which was not apparent in the current study. Although the incidence of alveolar/bronchiolar adenoma (18/50, 36%) in the 200 ppm male group is equal to the highest incidence seen in previous control groups for inhalation studies, the 86% survival of this group at 2 years was quite high and may have contributed to the apparent effect. For these reasons, the increased incidence of alveolar/bronchiolar adenoma in the 200 ppm males was not attributed to acetonitrile exposure.

The incidence of hepatocellular carcinoma was significantly increased in male mice exposed to 100 ppm acetonitrile. The incidence of hepatocellular adenoma or carcinoma (combined) was also increased in 100 ppm males. However, the incidences of hepatocellular neoplasms in 200 ppm males were less than those in the controls, and there was no indication of an effect of acetonitrile exposure on hepatocellular neoplasia in the females. The lack of evidence for a dose response in hepatocellular neoplasms in males coupled with an absence of confounding factors that would be expected to decrease the neoplasm response, such as a markedly lower body weight of 200 ppm males, suggests that this is a sporadic finding unrelated to acetonitrile exposure.

Acetonitrile was found to be nonmutagenic in studies with *Salmonella* and exhibited weak clastogenic effects in cultured mammalian cells. It also induced a marginal increase in micronucleated normochromatic erythrocytes in mice in the 13-week study. Nitriles have not been specifically designated as structural alerts for genotoxic activity (Ashby and Tennant, 1991).

## CONCLUSIONS

Under the conditions of these 2-year inhalation studies, there was *equivocal evidence of carcinogenic activity*\* of acetonitrile in male F344/N rats based on marginally increased incidences of hepatocellular adenoma and carcinoma. There was *no evidence of carcinogenic activity* of acetonitrile in female F344/N rats exposed to 100, 200, or 400 ppm. There was *no*

*evidence of carcinogenic activity* of acetonitrile in male or female B6C3F<sub>1</sub> mice exposed to 50, 100 or 200 ppm.

Exposure to acetonitrile by inhalation resulted in increased incidences of hepatic basophilic foci in male rats and of squamous hyperplasia of the fore-stomach in male and female mice.

---

\* Explanation of Levels of Evidence of Carcinogenic Activity is on page 9. A summary of the Technical Reports Review Subcommittee comments and the public discussion on this Technical Report appears on page 11.



## REFERENCES

- Ahmed, A.E., and Farooqui, M.Y.H. (1982). Comparative toxicities of aliphatic nitriles. *Toxicol. Lett.* **12**, 157-163.
- Ahmed, A.E., Loh, J.-P., Ghanayem, B., and Hussein, G.I. (1992). Studies on the mechanism of acetonitrile toxicity I: Whole body autoradiographic distribution and macromolecular interaction of 2-<sup>14</sup>C-acetonitrile in mice. *Pharmacol. Toxicol.* **70**, 322-330.
- Amdur, M.L. (1959). Accidental group exposure to acetonitrile. *J. Occup. Med.* **1**, 627-633.
- Amoore, J.E., and Hautala, E. (1983). Odor as an aid to chemical safety: Odor thresholds compared with threshold limit values and volatilities for 214 industrial chemicals in air and water dilution. *J. Appl. Toxicol.* **3**, 272-290.
- Armitage, P. (1971). *Statistical Methods in Medical Research*, pp. 362-365. John Wiley and Sons, New York.
- Ashby, J., and Tennant, R.W. (1991). Definitive relationships among chemical structure, carcinogenicity, and mutagenicity for 301 chemicals tested by the U.S. NTP. *Mutat. Res.* **257**, 229-306.
- Ballantyne, B. (1983). Artifacts in the definition of toxicity by cyanides and cyanogens. *Fundam. Appl. Toxicol.* **3**, 400-408.
- Becker, K.H., and Ionescu, A. (1982). Acetonitrile in the lower troposphere. *Geophys. Res. Lett.* **9**, 1349-1351.
- Berteau, P.E., Levinskas, G.J., and Rodwell, D.E. (1982). Teratogenic evaluation of aliphatic nitriles in rats. *Toxicologist* **2**, 118.
- Bioassay Systems Corp. (1984). *In vivo* gene mutation assay (HGPRT locus) in cultured Chinese hamster ovary (CHO) cells on acetonitrile. Revised Report (April 27, 1984). Project No. 11725.
- Boorman, G.A., Montgomery, C.A., Jr., Eustis, S.L., Wolfe, M.J., McConnell, E.E., and Hardisty, J.F. (1985). Quality assurance in pathology for rodent carcinogenicity studies. In *Handbook of Carcinogen Testing* (H.A. Milman and E.K. Weisburger, Eds.), pp. 345-357. Noyes Publications, Park Ridge, NJ.
- Borman, S. (1990). Acetonitrile shortage hurts research laboratories. *Chem. Eng. News* **68**, 15.
- Bringmann, G., and Kühn, R. (1980). Comparison of the toxicity thresholds of water pollutants to bacteria, algae, and protozoa in the cell multiplication inhibition test. *Water Res.* **14**, 231-241.
- Caravati, E.M., and Litovitz, T.L. (1988). Pediatric cyanide intoxication and death from an acetonitrile-containing cosmetic. *JAMA* **260**, 3470-3473.
- Code of Federal Regulations (CFR) **21**, Part 58.
- Cox, D.R. (1972). Regression models and life-tables. *J. R. Stat. Soc.* **B34**, 187-220.
- Crawford, B.D. (1985). Perspectives on the somatic mutation model of carcinogenesis. In *Advances in Modern Environmental Toxicology: Mechanisms and Toxicity of Chemical Carcinogens and Mutagens* (M.A. Mehlman, W.G. Flamm, and R.J. Lorentzen, Eds.), pp. 13-59. Princeton Scientific Publishing Co., Inc., Princeton, NJ.
- Dalhamn, T., Edfors, M.-L., and Rylander, R. (1968a). Retention of cigarette smoke components in human lungs. *Arch. Environ. Health* **17**, 746-748.
- Dalhamn, T., Edfors, M.-L., and Rylander, R. (1968b). Mouth absorption of various compounds in cigarette smoke. *Arch. Environ. Health* **16**, 831-835.
- DeQuidt, J., Furon, D., Wattel, F., Haguenoer, J.M., Scherpereel, P., Gosselin, B., and Ginestet, A. (1974). Les intoxications par l'acétonitrile à propos d'un cas mortel. *Eur. J. Toxicol. Environ. Hyg.* **7**, 91-97.

- Dinse, G.E., and Haseman, J.K. (1986). Logistic regression analysis of incidental-tumor data from animal carcinogenicity experiments. *Fundam. Appl. Toxicol.* **6**, 44-52.
- Dinse, G.E., and Lagakos, S.W. (1983). Regression analysis of tumour prevalence data. *Appl. Statist.* **32**, 236-248.
- Dixon, W.J., and Massey, F.J., Jr. (1951). *Introduction to Statistical Analysis*, 1st ed., pp. 145-147. McGraw-Hill Book Company, Inc., New York.
- Drew, R.T., Patel, J.M., and Lin, F.-N. (1978). Changes in serum enzymes in rats after inhalation of organic solvents singly and in combination. *Toxicol. Appl. Pharmacol.* **45**, 809-819.
- Dunn, O.J. (1964). Multiple comparisons using rank sums. *Technometrics* **6**, 241-252.
- Dunnett, C.W. (1955). A multiple comparison procedure for comparing several treatments with a control. *J. Am. Stat. Assoc.* **50**, 1096-1121.
- Fassett, D.W. (1963). Cyanide and nitriles. In *Patty's Industrial Hygiene and Toxicology* (F.A. Patty, Ed.). John Wiley and Sons, New York.
- Florin, I., Rutberg, L., Curvall, M., and Enzell, C.R. (1980). Screening of tobacco smoke constituents for mutagenicity using the Ames' test. *Toxicology* **18**, 219-232.
- Freeman, J.J., and Hayes, E.P. (1985a). Acetone potentiation of acute acetonitrile toxicity in rats. *J. Toxicol. Environ. Health* **15**, 609-621.
- Freeman, J.J., and Hayes, E.P. (1985b). Effects of acetone on microsomal metabolism of acetonitrile to cyanide. *Toxicologist* **5**, 246.
- Freeman, J.J., and Hayes, E.P. (1987). The metabolism of acetonitrile to cyanide by isolated rat hepatocytes. *Fundam. Appl. Toxicol.* **8**, 263-271.
- Galloway, S.M., Armstrong, M.J., Reuben, C., Colman, S., Brown, B., Cannon, C., Bloom, A.D., Nakamura, F., Ahmed, M., Duk, S., Rimpo, J., Margolin, B.H., Resnick, M.A., Anderson, B., and Zeiger, E. (1987). Chromosome aberrations and sister chromatid exchanges in Chinese hamster ovary cells: Evaluations of 108 chemicals. *Environ. Mol. Mutagen.* **10**, 1-175.
- Gart, J.J., Chu, K.C., and Tarone, R.E. (1979). Statistical issues in interpretation of chronic bioassay tests for carcinogenicity. *J. Natl. Cancer Inst.* **62**, 957-974.
- Geller, R.J., Ekins, B.R., and Iknoian, R.C. (1991). Cyanide toxicity from acetonitrile-containing false nail remover. *Am. J. Emerg. Med.* **9**, 268-270.
- Gergel, M.G., and Revelise, M. (1952). Nitriles and isocyanides. In *Kirk-Othmer Encyclopedia of Chemical Technology*, 1st ed., Vol. 9. (R.E. Kirk and D.F. Othmer, Eds.), pp. 352-374. The Interscience Encyclopedia, Inc., New York.
- Haguenoer, J.-M., DeQuidt, J., and Jacquemont, M.-C. (1975a). Intoxications expérimentales par l'acétonitrile. 1<sup>re</sup> note: Intoxications aiguës par voie intrapéritonéale. *Eur. J. Toxicol.* **8**, 94-101.
- Haguenoer, J.-M., DeQuidt, J., and Jacquemont, M.-C. (1975b). Intoxications expérimentales par l'acétonitrile. 2<sup>e</sup> note: Intoxications aiguës par voie pulmonaire. *Eur. J. Toxicol.* **8**, 102-106.
- Harada, T., Maronpot, R.R., Morris, R.W., and Boorman, G.A. (1989). Observations on altered hepatocellular foci in National Toxicology Program two-year carcinogenicity studies in rats. *Toxicol. Pathol.* **17**, 690-708.
- Haseman, J.K. (1984). Statistical issues in the design, analysis and interpretation of animal carcinogenicity studies. *Environ. Health Perspect.* **58**, 385-392.
- Haseman, J.K., Huff, J., and Boorman, G.A. (1984). Use of historical control data in carcinogenicity studies in rodents. *Toxicol. Pathol.* **12**, 126-135.



- Haseman, J.K., Huff, J.E., Rao, G.N., Arnold, J.E., Boorman, G.A., and McConnell, E.E. (1985). Neoplasms observed in untreated and corn oil gavage control groups of F344/N rats and (C57BL/6N × C3H/HeN)F<sub>1</sub> (B6C3F<sub>1</sub>) mice. *JNCI* **75**, 975-984.
- Hollander, M., and Wolfe, D.A. (1973). *Nonparametric Statistical Methods*, pp. 120-123. John Wiley and Sons, New York.
- Jaeger, A., Tempe, J.D., Porte, A., Stoeckel, L., and Mantz, J.M. (1977). Acute voluntary intoxication by acetonitrile. *Acta Pharmacol. Toxicol.* **41**, 340 (Abstr.).
- Jonckheere, A.R. (1954). A distribution-free *k*-sample test against ordered alternatives. *Biometrika* **41**, 133-145.
- Jones, A.W., Löfgren, A., and Eklund, A. (1992). Two fatalities from ingestion of acetonitrile: Limited specificity of analysis by headspace gas chromatography. *J. Anal. Toxicol.* **16**, 104-106.
- Kaplan, E.L., and Meier, P. (1958). Nonparametric estimation from incomplete observations. *J. Am. Stat. Assoc.* **53**, 457-481.
- Kimura, E.T., Ebert, D.M., and Dodge, P.W. (1971). Acute toxicity and limits of solvent residue for sixteen organic solvents. *Toxicol. Appl. Pharmacol.* **19**, 699-704.
- Klaassen, C.D., Amdur, M.O., and Doull, J. (1986). In *Casarett and Doull's Toxicology*, pp. 241, 372, and 888. MacMillan Publishing Co., New York.
- Koop, D.R., and Casazza, J.P. (1985). Identification of ethanol-inducible P-450 isozyme 3a as the acetone and acetol monooxygenase of rabbit microsomes. *J. Biol. Chem.* **260**, 13,607-13,612.
- Kushi, A., Matsumoto, T., and Yoshida, D. (1983). Mutagen from the gaseous phase of protein pyrolyzate. *Agric. Biol. Chem.* **47**, 1979-1982.
- Levene, C.I. (1961). Structural requirements for lathyrogenic agents. *J. Exp. Med.* **114**, 295-311.
- Losek, J.D., Rock, A.L., and Boldt, R.R. (1991). Cyanide poisoning from a cosmetic nail remover. *Pediatrics* **88**, 337-340.
- Ludzack, F.J., Schaffer, R.B., and Bloomhuff, R.N. (1961). Experimental treatment of organic cyanides by conventional processes. *J. Water Pollut. Control Fed.* **33**, 492-505.
- Lyman, W.J., Reehl, W.F., and Rosenblatt, D.H. (1982). *Handbook of Chemical Property Estimation Methods*. McGraw-Hill, Inc., New York.
- McConnell, E.E., Solleveld, H.A., Swenberg, J.A., and Boorman, G.A. (1986). Guidelines for combining neoplasms for evaluation of rodent carcinogenesis studies. *JNCI* **76**, 283-289.
- MacGregor, J.T., Wehr, C.M., and Langlois, R.G. (1983). A simple fluorescent staining procedure for micronuclei and RNA in erythrocytes using Hoechst 33258 and pyronin Y. *Mutat. Res.* **120**, 269-275.
- MacGregor, J.T., Wehr, C.M., Henika, P.R., and Shelby, M.D. (1990). The *in vivo* erythrocyte micronucleus test: Measurement at steady state increases assay efficiency and permits integration with toxicity studies. *Fundam. Appl. Toxicol.* **14**, 513-522.
- McKee, H.C., Rhoades, J.W., Campbell, J., and Gross, A.L. (1962). Acetonitrile in body fluids related to smoking. *Public Health Rep.* **77**, 553-554.
- McKnight, B., and Crowley, J. (1984). Tests for differences in tumor incidence based on animal carcinogenesis experiments. *J. Am. Stat. Assoc.* **79**, 639-648.
- Margolin, B.H., Risko, K.J., Frome, E.L., and Tice, R.R. (1990). *A General Purpose Statistical Analysis Program for Micronucleus Assay Data. Appendix 2: Micronucleus Assay Data Management and Analysis System, Version 1.4a*. Integrated Laboratory Systems, Research Triangle Park, NC.
- Maron, D., Katzenellenbogen, J., and Ames, B.N. (1981). Compatibility of organic solvents with the *Salmonella*/microsome test. *Mutat. Res.* **88**, 343-350.
- Maronpot, R.R., and Boorman, G.A. (1982). Interpretation of rodent hepatocellular proliferative alterations and hepatocellular tumors in chemical safety assessment. *Toxicol. Pathol.* **10**, 71-80.

Melnick, R.L., Roycroft, J.H., Chou, B.J., Ragan, H.A., and Miller, R.A. (1990). Inhalation toxicology of isoprene in F344 rats and B6C3F<sub>1</sub> mice following two-week exposures. *Environ. Health Perspect.* **86**, 93-98.

*The Merck Index* (1976). 9th ed. (W. Windholz, Ed.), p. 8. Merck and Company, Rahway, NJ.

*The Merck Index* (1989). 11th ed. (S. Budavari, Ed.), p. 11. Merck and Company, Rahway, NJ.

Michaelis, H.C., Clemens, C., Kijewski, H., Neurath, H., and Eggert, A. (1991). Acetonitrile serum concentrations and cyanide blood levels in a case of suicidal oral acetonitrile ingestion. *Clin. Toxicol.* **29**, 447-458.

Miller, J.A., and Miller, E.C. (1977). Ultimate chemical carcinogens as reactive mutagenic electrophiles. In *Origins of Human Cancer* (H.H. Hiatt, J.D. Watson, and J.A. Winsten, Eds.), pp. 605-627. Cold Spring Harbor Laboratory, Cold Spring Harbor, NY.

Mirsalis, J., Tyson, K., Beck, J., Loh, F., Steinmetz, K., Contreras, C., Austere, L., Martin, S., and Spalding, J. (1983). Induction of unscheduled DNA synthesis (UDS) in hepatocytes following *in vitro* and *in vivo* treatment. *Environ. Mutagen.* **5**, 482 (Abstr.).

Morrissey, R.E., Schwetz, B.A., Lamb, J.C., IV, Ross, M.D., Teague, J.L., and Morris, R.W. (1988). Evaluation of rodent sperm, vaginal cytology, and reproductive organ weight data from National Toxicology Program 13-week studies. *Fundam. Appl. Toxicol.* **11**, 343-358.

Mortelmans, K., Haworth, S., Lawlor, T., Speck, W., Tainer, B., and Zeiger, E. (1986). *Salmonella* mutagenicity tests: II. Results from the testing of 270 chemicals. *Environ. Mutagen.* **8** (Suppl. 7), 1-119.

National Cancer Institute (NCI) (1976). Guidelines for Carcinogen Bioassay in Small Rodents. Technical Report Series No. 1. NIH Publication No. 76-801. U.S. Department of Health, Education, and Welfare, Public Health Service, National Institutes of Health, Bethesda, MD.

National Institute for Occupational Safety and Health (NIOSH) (1979). National occupational hazards survey: Updated projection data collected 1972-1974. Cincinnati, OH.

National Institute for Occupational Safety and Health (NIOSH) (1994). National Occupational Exposure Survey (NOES) (1981-1983), unpublished provisional data as of January 31, 1994.

National Institutes of Health (NIH) (1978). Open Formula Rat and Mouse Ration (NIH-07). Specification NIH-11-1335. U.S. Department of Health, Education, and Welfare, Public Health Service, National Institutes of Health, Bethesda, MD.

National Toxicology Program (NTP) (1989). Toxicology and Carcinogenesis Studies of 2,4-Dichlorophenol (CAS No. 120-83-2) in F344/N Rats and B6C3F<sub>1</sub> Mice (Feed Studies). Technical Report Series No. 353. NIH Publication No. 89-2808. U.S. Department of Health and Human Services, Public Health Service, National Institutes of Health, Research Triangle Park, NC.

National Toxicology Program (NTP) (1991). Toxicology and Carcinogenesis Studies of *dl*-Amphetamine Sulfate (CAS No. 60-13-9) in F344/N Rats and B6C3F<sub>1</sub> Mice (Feed Studies). Technical Report Series No. 387. NIH Publication No. 91-2842. U.S. Department of Health and Human Services, Public Health Service, National Institutes of Health, Research Triangle Park, NC.

National Toxicology Program (NTP) (1993). Toxicology and Carcinogenesis Studies of Tumeric Oleoresin (CAS No. 8024-37-1) (Major Component 79%-85% Curcumin, CAS No. 458-37-7) in F344/N Rats and B6C3F<sub>1</sub> Mice (Feed Studies). Technical Report Series No. 427. NIH Publication No. 93-3158. U.S. Department of Health and Human Services, Public Health Service, National Institutes of Health, Research Triangle Park, NC.

National Toxicology Program (NTP) (1994a). Inhalation Developmental Toxicology Studies: Acetonitrile in Rats. National Institutes of Health, Research Triangle Park, NC.

- National Toxicology Program (NTP) (1994b). Toxicology and Carcinogenesis Studies of Triamterene (CAS No. 396-01-0) in F344/N Rats and B6C3F<sub>1</sub> Mice (Feed Studies). Technical Report Series No. 420. NIH Publication No. 94-3151. U.S. Department of Health and Human Services, Public Health Service, National Institutes of Health, Research Triangle Park, NC.
- Nishiuchi, Y. (1981). Toxicity of pesticides to some aquatic animals. II. Toxicity of several solvents to carp and daphnids [in Japanese]. *Seikagaku* 4, 45-47.
- Office of Health Studies (OHS), Department of Environmental Health, Environmental Agency, Japan (1990). Chemicals in the environment. The annual report of chemical assessment [in Japanese]. Tokyo, Environment Agency, pp. 492-493 (Office of Health Studies Report Series).
- Ohkawa, H., Ohkawa, R., Yamamoto, I., and Casida, J.E. (1972). Enzymatic mechanisms and toxicological significance of hydrogen cyanide liberation from various organothiocyanates and organonitriles in mice and houseflies. *Pestic. Biochem. Physiol.* 2, 95-112.
- Osgood, C., Zimmering, S., and Mason, J.M. (1991a). Aneuploidy in *Drosophila*, II. Further validation of the FIX and ZESTE genetic test systems employing female *Drosophila melanogaster*. *Mutat. Res.* 259, 147-163.
- Osgood, C., Bloomfield, M., and Zimmering, S. (1991b). Aneuploidy in *Drosophila*. IV. Inhalation studies on the induction of aneuploidy by nitriles. *Mutat. Res.* 259, 165-176.
- Patty's Industrial Hygiene and Toxicology* (1982). 3rd ed. (G.D. Clayton and F.E. Clayton, Eds.) Vol. 2C, John Wiley and Sons, New York.
- Pozzani, U.C., Carpenter, C.P., Palm, P.E., Weil, C.S., and Nair, J.H., III. (1959a). An investigation of the mammalian toxicity of acetonitrile. *J. Occup. Med.* 1, 634-642.
- Pozzani, U.C., Weil, C.S., and Carpenter, C.P. (1959b). The toxicological basis of threshold limit values: 5. The experimental inhalation of vapor mixtures by rats, with notes upon the relationship between single dose inhalation and single dose oral data. *Ind. Hyg. J.* 20, 364-369.
- Reynolds, J.E.F., and Prasad, A.B., Eds. (1982). *Martindale: The Extra Pharmacopoeia*, 28th ed. The Pharmaceutical Press, London.
- Roloff, V., Short, R., Ribelin, W., and Dietrich, M. (1985). Comparison of subchronic inhalation toxicity of five aliphatic nitriles in rats. *Toxicologist* 5, 30.
- Rudd, C.J., Mitchell, A.D., and Spalding, J. (1983). L5178Y mouse lymphoma cell mutagenesis assay of coded chemicals incorporating analyses of the colony size distributions. *Environ. Mutagen.* 5, 419 (Abstr.).
- Sadtler Standard Spectra*. IR No. 269; NMR No. 9154M. Sadtler Research Laboratories, Philadelphia.
- Schlegelmilch, R., Krug, A., and Wolf, H.U. (1988). Mutagenic activity of acetonitrile and fumaronitrile in three short term assays with special reference to autoinduction. *J. Appl. Toxicol.* 8, 201-209.
- Schmid, W. (1976). The micronucleus test for cytogenetic analysis. In *Chemical Mutagens: Principles and Methods for their Detection* (A. Hollaender, Ed.), Vol. 4, pp. 31-53. Plenum Press, New York.
- Shirley, E. (1977). A non-parametric equivalent of Williams' test for contrasting increasing dose levels of a treatment. *Biometrics* 33, 386-389.
- Smith, M.K., George, E.L., Zenick, H., Manson, J.M., and Stober, J.A. (1987). Developmental toxicity of halogenated acetonitriles: Drinking water by-products of chlorine disinfection. *Toxicology* 46, 83-93.
- Smyth, H.F., Jr., and Carpenter, C.P. (1948). Further experience with the range finding test in the industrial toxicology laboratory. *J. Ind. Hyg. Toxicol.* 30, 63-68.
- Straus, D.S. (1981). Somatic mutation, cellular differentiation, and cancer causation. *JNCI* 67, 233-241.
- Tanii, H., and Hashimoto, K. (1984). Studies on the mechanism of acute toxicity of nitriles in mice. *Arch. Toxicol.* 55, 47-54.
- Tarone, R.E. (1975). Tests for trend in life table analysis. *Biometrika* 62, 679-682.

- Tennant, R.W., Margolin, B.H., Shelby, M.D., Zeiger, E., Haseman, J.K., Spalding, J., Caspary, W., Resnick, M., Stasiewicz, S., Anderson, B., and Minor, R. (1987). Prediction of chemical carcinogenicity in rodents from *in vitro* genetic toxicity assays. *Science* **236**, 933-941.
- Turchen, S.G., Manoguerra, A.S., and Whitney, C. (1991). Severe cyanide poisoning from the ingestion of acetonitrile-containing cosmetic. *Am. J. Emerg. Med.* **9**, 264-267.
- United States Environmental Protection Agency (USEPA) (1985). Health and environmental effects profile for acetonitrile. Office of Solid Waste and Emergency Response, Washington, DC.
- United States International Trade Commission (USITC) (1993). Synthetic organic chemicals: United States Production and Sales, 1991. USITC Publication 2607. U.S. Government Printing Office, Washington, DC.
- Verbrugge, R. (1899). Toxicité des mononitriles gras et aromatiques et action antitoxique de l'hyposulfite de soude vis à vis de ces mononitriles. *Arch. Int. Pharmacodyn. Ther.* **5**, 161-197.
- Way, J.L. (1981). Pharmacologic aspects of cyanide and its antagonism. In *Cyanide in Biology* (B. Vennesland, E.E. Conn, C.J. Knowles, J. Westley, and F. Wissing, Eds.), pp. 29-49. Academic Press, New York.
- Whittaker, S.G., Zimmerman, F.K., Dicus, B., Piegorsch, W.W., Fogel, S., and Resnick, M.A. (1989). Detection of induced mitotic chromosome loss in *Saccharomyces cerevisiae* — an interlaboratory study. *Mutat. Res.* **224**, 31-78.
- Whittaker, S.G., Moser, S.F., Maloney, D.H., Piegorsch, W.W., Resnick, M.A., and Fogel, S. (1990). The detection of mitotic and meiotic chromosome gain in the yeast *Saccharomyces cerevisiae*: Effects of methyl benzimidazol-2-yl carbamate, methyl methanesulfonate, ethyl methanesulfonate, dimethyl sulfoxide, propionitrile and cyclophosphamide monohydrate. *Mutat. Res.* **242**, 231-258.
- Willhite, C.C. (1981). Inhalation toxicology of acute exposure to aliphatic nitriles. *Clin. Toxicol.* **18**, 991-1003.
- Willhite, C.C. (1983). Developmental toxicology of acetonitrile in the Syrian golden hamster. *Teratology* **27**, 313-325.
- Willhite, C.C., and Smith, R.P. (1981). The role of cyanide liberation in the acute toxicity of aliphatic nitriles. *Toxicol. Appl. Pharmacol.* **59**, 589-602.
- Williams, D.A. (1971). A test for differences between treatment means when several dose levels are compared with a zero dose control. *Biometrics* **27**, 103-117.
- Williams, D.A. (1972). The comparison of several dose levels with a zero dose control. *Biometrics* **28**, 519-531.
- Woolley, W.D. (1972). Nitrogen-containing products from the thermal decomposition of flexible polyurethane foams. *Br. Polym. J.* **4**, 27-43.
- World Health Organization (WHO) (1993). Environmental Health Criteria: Acetonitrile. Technical Report Series 154. World Health Organization, Geneva.
- Zeiger, E., Anderson, B., Haworth, S., Lawlor, T., and Mortelmans, K. (1988). *Salmonella* mutagenicity tests: IV. Results from the testing of 300 chemicals. *Environ. Mol. Mutagen.* **11** (Suppl. 12), 1-158.
- Zeiger, E., Haseman, J.K., Shelby, M.D., Margolin, B.H., and Tennant, R.W. (1990). Evaluation of four *in vitro* genetic toxicity tests for predicting rodent carcinogenicity: Confirmation of earlier results with 41 additional chemicals. *Environ. Mol. Mutagen.* **16** (Suppl. 18), 1-14.
- Zimmerman, F.K., Mayer, V.W., Scheel, I., and Resnick, M.A. (1985). Acetone, methyl ethyl ketone, ethyl acetate, acetonitrile and other polar aprotic solvents are strong inducers of aneuploidy in *Saccharomyces cerevisiae*. *Mutat. Res.* **149**, 339-351.
- Zimmerman, F.K., Scheel, I., and Resnick, M.A. (1989). Induction of chromosome loss by mixtures of organic solvents including neurotoxins. *Mutat. Res.* **224**, 287-303.

## APPENDIX A

### SUMMARY OF LESIONS IN MALE RATS IN THE 2-YEAR INHALATION STUDY OF ACETONITRILE

TABLE A1	Summary of the Incidence of Neoplasms in Male Rats in the 2-Year Inhalation Study of Acetonitrile .....	67
TABLE A2	Individual Animal Tumor Pathology of Male Rats in the 2-Year Inhalation Study of Acetonitrile .....	72
TABLE A3	Statistical Analysis of Primary Neoplasms in Male Rats in the 2-Year Inhalation Study of Acetonitrile .....	90
TABLE A4a	Historical Incidence of Hepatocellular Neoplasms in Untreated Male F344/N Rats .....	96
TABLE A4b	Historical Incidence of Adrenal Gland Pheochromocytomas in Untreated Male F344/N Rats .....	96
TABLE A4c	Historical Incidence of Pancreatic Islet Neoplasms in Untreated Male F344/N Rats ...	97
TABLE A4d	Historical Incidence of Skin Keratoacanthomas in Untreated Male F344/N Rats .....	97
TABLE A5	Summary of the Incidence of Nonneoplastic Lesions in Male Rats in the 2-Year Inhalation Study of Acetonitrile .....	98



**TABLE A1**  
**Summary of the Incidence of Neoplasms in Male Rats in the 2-Year Inhalation Study of Acetonitrile<sup>a</sup>**

	0 ppm	100 ppm	200 ppm	400 ppm
<b>Disposition Summary</b>				
Animals initially in study	56	55	56	56
<b>15-Month interim evaluation</b>	8	8	8	8
Early deaths				
Moribund	36	26	35	26
Natural deaths	1	8	4	5
Survivors				
Terminal sacrifice	11	13	9	17
Animals examined microscopically	56	55	56	56
<b>15-Month Interim Evaluation</b>				
<b>Endocrine System</b>				
Adrenal medulla	(8)	(7)	(5)	(8)
Pheochromocytoma malignant		1 (14%)		
Pheochromocytoma benign		1 (14%)		
Pituitary gland	(8)	(7)	(8)	(7)
Pars distalis, adenoma	2 (25%)	2 (29%)	2 (25%)	
Pars intermedia, adenoma	1 (13%)			
Thyroid gland	(8)	(8)	(8)	(8)
C-cell, adenoma			1 (13%)	
<b>Genital System</b>				
Testes	(8)	(8)	(8)	(8)
Bilateral, interstitial cell, adenoma	3 (38%)	1 (13%)	3 (38%)	8 (100%)
Interstitial cell, adenoma	3 (38%)	7 (88%)	5 (63%)	
<b>Integumentary System</b>				
Skin	(8)	(8)	(8)	(8)
Keratoacanthoma	1 (13%)			
<b>Systems Examined With No Neoplasms Observed</b>				
Alimentary System				
Cardiovascular System				
General Body System				
Hematopoietic System				
Musculoskeletal System				
Nervous System				
Respiratory System				
Special Senses System				
Urinary System				

**TABLE A1**  
**Summary of the Incidence of Neoplasms in Male Rats in the 2-Year Inhalation Study of Acetonitrile (continued)**

	0 ppm	100 ppm	200 ppm	400 ppm
<b>2-Year Study</b>				
<b>Alimentary System</b>				
Intestine large, colon	(48)	(42)	(46)	(45)
Intestine small, jejunum	(47)	(42)	(46)	(44)
Carcinoma				1 (2%)
Fibrosarcoma	1 (2%)			
Intestine small, ileum	(47)	(42)	(46)	(43)
Liver	(48)	(47)	(48)	(48)
Hepatocellular carcinoma	1 (2%)			2 (4%)
Hepatocellular carcinoma, multiple				1 (2%)
Hepatocellular adenoma		1 (2%)	1 (2%)	3 (6%)
Osteosarcoma, metastatic, bone			1 (2%)	
Mesentery	(10)	(9)	(9)	(11)
Pancreas	(48)	(47)	(48)	(48)
Adenoma				1 (2%)
Pharynx		(1)		(1)
Squamous cell papilloma		1 (100%)		1 (100%)
Stomach, forestomach	(48)	(47)	(48)	(47)
Stomach, glandular	(48)	(46)	(48)	(47)
Tongue		(2)		(1)
Squamous cell carcinoma		1 (50%)		1 (100%)
<b>Cardiovascular System</b>				
Heart	(48)	(47)	(48)	(48)
<b>Endocrine System</b>				
Adrenal medulla	(48)	(46)	(48)	(48)
Pheochromocytoma malignant		1 (2%)	2 (4%)	1 (2%)
Pheochromocytoma benign	2 (4%)	10 (22%)	10 (21%)	6 (13%)
Bilateral, pheochromocytoma benign	2 (4%)	4 (9%)	2 (4%)	1 (2%)
Islets, pancreatic	(48)	(47)	(48)	(48)
Adenoma	1 (2%)	4 (9%)	4 (8%)	1 (2%)
Adenoma, multiple			1 (2%)	
Carcinoma	1 (2%)		3 (6%)	1 (2%)
Pituitary gland	(48)	(46)	(48)	(47)
Pars distalis, adenoma	25 (52%)	27 (59%)	23 (48%)	23 (49%)
Pars intermedia, adenoma	1 (2%)			
Thyroid gland	(48)	(47)	(48)	(48)
Bilateral, C-cell, adenoma			1 (2%)	
Bilateral, C-cell, carcinoma				1 (2%)
C-cell, adenoma	6 (13%)	5 (11%)	6 (13%)	6 (13%)
C-cell, carcinoma	3 (6%)	1 (2%)		
Follicular cell, adenoma		1 (2%)		
Follicular cell, carcinoma			1 (2%)	
<b>General Body System</b>				
None				



**TABLE A1**  
**Summary of the Incidence of Neoplasms in Male Rats in the 2-Year Inhalation Study of Acetonitrile (continued)**

	0 ppm	100 ppm	200 ppm	400 ppm
<b>2-Year Study (continued)</b>				
<b>Genital System</b>				
Epididymis	(48)	(47)	(48)	(48)
Preputial gland	(47)	(47)	(47)	(48)
Adenoma			1 (2%)	
Carcinoma	5 (11%)	1 (2%)	2 (4%)	1 (2%)
Testes	(48)	(47)	(48)	(48)
Osteosarcoma, metastatic, bone			1 (2%)	
Bilateral, interstitial cell, adenoma	25 (52%)	29 (62%)	30 (63%)	34 (71%)
Interstitial cell, adenoma	8 (17%)	6 (13%)	10 (21%)	8 (17%)
<b>Hematopoietic System</b>				
Bone marrow	(48)	(47)	(48)	(48)
Lymph node	(12)	(7)	(13)	(12)
Axillary, osteosarcoma, metastatic, bone			1 (8%)	
Lymph node, bronchial	(41)	(40)	(40)	(41)
Osteosarcoma, metastatic, bone			1 (3%)	
Lymph node, mandibular	(43)	(43)	(45)	(47)
Lymph node, mesenteric	(48)	(47)	(47)	(48)
Lymph node, mediastinal	(48)	(46)	(48)	(48)
Spleen	(48)	(47)	(48)	(48)
Fibrosarcoma				1 (2%)
Osteosarcoma, metastatic, bone			1 (2%)	
Sarcoma		2 (4%)		
Thymus	(48)	(45)	(47)	(48)
Thymoma NOS			1 (2%)	
<b>Integumentary System</b>				
Mammary gland	(47)	(47)	(48)	(48)
Carcinoma			1 (2%)	1 (2%)
Fibroadenoma		2 (4%)		2 (4%)
Skin	(48)	(47)	(48)	(48)
Basal cell adenoma		1 (2%)		1 (2%)
Fibroma	3 (6%)	2 (4%)		3 (6%)
Fibroma, multiple			1 (2%)	
Fibrosarcoma		1 (2%)		
Hemangiopericytoma			1 (2%)	
Keratoacanthoma		1 (2%)		4 (8%)
Trichoepithelioma			1 (2%)	
Sebaceous gland, carcinoma				1 (2%)
<b>Musculoskeletal System</b>				
Bone	(48)	(47)	(48)	(48)
Humerus, osteosarcoma			1 (2%)	
Rib, osteosarcoma	1 (2%)			

**TABLE A1**  
**Summary of the Incidence of Neoplasms in Male Rats in the 2-Year Inhalation Study of Acetonitrile** (continued)

	0 ppm	100 ppm	200 ppm	400 ppm
<b>2-Year Study</b> (continued)				
<b>Nervous System</b>				
Brain	(48)	(47)	(48)	(48)
Astrocytoma NOS				1 (2%)
Glioma malignant	1 (2%)			
Glioma NOS				1 (2%)
Oligodendroglioma NOS		1 (2%)		
Sarcoma, metastatic, spleen		1 (2%)		
Meninges, meningioma benign			1 (2%)	
<b>Respiratory System</b>				
Lung	(48)	(47)	(48)	(48)
Alveolar/bronchiolar adenoma	1 (2%)	1 (2%)		
Alveolar/bronchiolar carcinoma	1 (2%)	1 (2%)	1 (2%)	
Carcinoma, metastatic, thyroid gland				1 (2%)
Neoplasm nos, metastatic, uncertain primary site	1 (2%)			
Osteosarcoma, metastatic, bone	1 (2%)		1 (2%)	
Pheochromocytoma malignant, metastatic, adrenal medulla				1 (2%)
<b>Special Senses System</b>				
Ear	(2)			
Pinna, schwannoma benign	1 (50%)			
Zymbal's gland				(1)
Carcinoma				1 (100%)
<b>Urinary System</b>				
Kidney	(48)	(47)	(48)	(48)
Renal tubule, adenoma	1 (2%)			
Urinary bladder	(48)	(47)	(48)	(48)
Transitional epithelium, carcinoma			1 (2%)	
<b>Systemic Lesions</b>				
Multiple organs <sup>b</sup>	(48)	(47)	(48)	(48)
Leukemia mononuclear	29 (60%)	32 (68%)	35 (73%)	32 (67%)
Mesothelioma NOS	3 (6%)	5 (11%)	2 (4%)	1 (2%)

**TABLE A1**  
**Summary of the Incidence of Neoplasms in Male Rats in the 2-Year Inhalation Study of Acetonitrile (continued)**

	0 ppm	100 ppm	200 ppm	400 ppm
<b>Neoplasm Summary</b>				
Total animals with primary neoplasms <sup>c</sup>				
15-Month interim evaluation	8	8	8	8
2-Year study	48	47	48	48
Total primary neoplasms				
15-Month interim evaluation	10	12	11	8
2-Year study	122	141	143	142
Total animals with benign neoplasms				
15-Month interim evaluation	8	8	8	8
2-Year study	45	45	45	47
Total benign neoplasms				
15-Month interim evaluation	10	11	11	8
2-Year study	76	95	93	94
Total animals with malignant neoplasms				
15-Month interim evaluation		1		
2-Year study	36	35	38	34
Total malignant neoplasms				
15-Month interim evaluation		1		
2-Year study	43	40	47	45
Total animals with metastatic neoplasms				
2-Year study	3	1	1	2
Total metastatic neoplasms				
2-Year study	4	1	6	2
Total animals with malignant neoplasms- uncertain primary site				
2-Year study	1			
Total animals with uncertain neoplasms- benign or malignant				
2-Year study	3	6	3	3
Total uncertain neoplasms				
2-Year study	7	10	6	6

<sup>a</sup> Number of animals examined microscopically at the site and the number of animals with neoplasm

<sup>b</sup> Number of animals with any tissue examined microscopically

<sup>c</sup> Primary neoplasms: all neoplasms except metastatic neoplasms

**TABLE A2**  
**Individual Animal Tumor Pathology of Male Rats in the 2-Year Inhalation Study of Acetonitrile: 0 ppm**

Number of Days on Study	3	4	4	4	4	5	5	5	5	5	5	5	5	5	5	6	6	6	6	6	6	6	6	6	6	6	6	
Carcass ID Number	9	1	7	8	9	1	2	2	3	4	6	6	8	9	0	0	2	3	3	4	5	5	5	7	7			
	4	8	2	3	2	1	0	4	9	6	1	6	7	7	2	9	3	2	7	6	1	1	2	4	9			
<b>Alimentary System</b>	0	0	0	0	0	0	0	0	0	0	0	0	0	0	0	0	0	0	0	0	0	0	0	0	0	0	0	
Esophagus	1	3	3	0	3	3	3	1	3	5	2	1	1	3	5	2	1	0	0	1	0	0	1	4	2			
Intestine large, colon	6	1	4	7	7	9	2	0	6	1	5	1	7	8	2	0	3	4	3	9	6	9	2	7	1			
Intestine large, rectum	+	+	+	+	+	+	+	+	+	+	+	+	+	+	+	+	+	+	+	+	+	+	+	+	+	+	+	
Intestine large, cecum	+	+	+	+	+	+	+	+	+	+	+	+	+	+	+	+	+	+	+	+	+	+	+	+	+	+	+	
Intestine small, duodenum	+	+	+	+	+	+	+	+	+	+	+	+	+	+	+	+	+	+	+	+	+	+	+	+	+	+	+	
Intestine small, jejunum	+	+	+	+	+	+	+	+	+	+	+	+	+	+	+	+	+	+	+	+	+	+	+	+	+	+	+	
Fibrosarcoma																												
Intestine small, ileum	+	+	+	+	+	+	+	+	+	+	+	+	+	+	+	+	+	+	+	+	+	+	+	+	+	+	+	
Liver	+	+	+	+	+	+	+	+	+	+	+	+	+	+	+	+	+	+	+	+	+	+	+	+	+	+	+	
Hepatocellular carcinoma																												
Mesentery								+	+				+				+	+										
Pancreas	+	+	+	+	+	+	+	+	+	+	+	+	+	+	+	+	+	+	+	+	+	+	+	+	+	+	+	
Salivary glands	+	+	+	+	+	+	+	+	+	+	+	+	+	+	+	+	+	+	+	+	+	+	+	+	+	+	+	
Stomach, forestomach	+	+	+	+	+	+	+	+	+	+	+	+	+	+	+	+	+	+	+	+	+	+	+	+	+	+	+	
Stomach, glandular	+	+	+	+	+	+	+	+	+	+	+	+	+	+	+	+	+	+	+	+	+	+	+	+	+	+	+	
<b>Cardiovascular System</b>																												
Blood vessel	+	+	+	+	+	+	+	+	+	+	+	+	+	+	+	+	+	+	+	+	+	+	+	+	+	+	+	
Heart	+	+	+	+	+	+	+	+	+	+	+	+	+	+	+	+	+	+	+	+	+	+	+	+	+	+	+	
Mesothelioma NOS, metastatic, testes																												
<b>Endocrine System</b>																												
Adrenal cortex	+	+	+	+	+	+	+	+	+	+	+	+	+	+	+	+	+	+	+	+	+	+	+	+	+	+	+	
Adrenal medulla	+	+	+	+	+	+	+	+	+	+	+	+	+	+	+	+	+	+	+	+	+	+	+	+	+	+	+	
Pheochromocytoma benign																												
Bilateral, pheochromocytoma benign																												
Islets, pancreatic	+	+	+	+	+	+	+	+	+	+	+	+	+	+	+	+	+	+	+	+	+	+	+	+	+	+	+	
Adenoma																												
Carcinoma																												
Parathyroid gland	+	+	+	+	+	M	+	+	+	+	+	+	+	+	+	+	+	+	+	+	+	+	+	+	+	+	+	
Pituitary gland	+	+	+	+	+	+	+	+	+	+	+	+	+	+	+	+	+	+	+	+	+	+	+	+	+	+	+	
Pars distalis, adenoma	X	X	X			X	X			X	X	X				X	X	X	X	X								
Pars intermedia, adenoma																												
Thyroid gland	+	+	+	+	+	+	+	+	+	+	+	+	+	+	+	+	+	+	+	+	+	+	+	+	+	+	+	
C-cell, adenoma																												
C-cell, carcinoma																												
<b>General Body System</b>																												
None																												
<b>Genital System</b>																												
Epididymis	+	+	+	+	+	+	+	+	+	+	+	+	+	+	+	+	+	+	+	+	+	+	+	+	+	+	+	
Preputial gland	M	+	+	+	+	+	+	+	+	+	+	+	+	+	+	+	+	+	+	+	+	+	+	+	+	+	+	
Carcinoma																												
Prostate	+	+	+	+	+	+	+	+	+	+	+	+	+	+	+	+	+	+	+	+	+	+	+	+	+	+	+	
Seminal vesicle	+	+	+	+	+	+	+	+	+	+	+	+	+	+	+	+	+	+	+	+	+	+	+	+	+	+	+	
Testes	+	+	+	+	+	+	+	+	+	+	+	+	+	+	+	+	+	+	+	+	+	+	+	+	+	+	+	
Bilateral, interstitial cell, adenoma																												
Interstitial cell, adenoma																												

+: Tissue examined microscopically  
M: Missing tissue  
A: Autolysis precludes examination  
I: Insufficient tissue  
X: Lesion present  
Blank: Not examined







**TABLE A2**  
**Individual Animal Tumor Pathology of Male Rats in the 2-Year Inhalation Study of Acetonitrile: 100 ppm**

Number of Days on Study	3	4	4	5	5	5	5	5	5	5	5	5	5	5	5	5	5	5	5	6	6	6	6	6	6
	3	4	9	1	2	3	5	5	5	6	6	6	6	8	8	8	9	9	2	3	3	4	5	6	
	1	6	6	7	5	0	5	8	9	0	1	4	7	6	6	8	0	5	3	7	9	2	3	5	
Carcass ID Number	1	1	1	1	1	1	1	1	1	1	1	1	1	1	1	1	1	1	1	1	1	1	1	1	
	4	4	2	5	3	3	2	2	6	1	6	2	3	4	4	5	3	3	3	1	4	1	6	5	
	9	0	3	7	3	7	7	4	3	3	5	8	8	2	4	9	9	5	6	9	5	7	2	1	
<b>Alimentary System</b>																									
Esophagus	+	+	+	+	+	+	+	+	+	+	+	+	+	+	+	+	+	+	+	+	+	+	+	+	+
Intestine large, colon	+	+	A	+	+	+	+	A	+	+	+	+	+	+	+	A	+	A	+	+	+	+	+	+	+
Intestine large, rectum	+	+	+	+	+	+	+	+	+	+	+	+	+	+	+	A	+	A	+	+	+	+	+	+	+
Intestine large, cecum	+	+	A	+	+	+	+	+	M	+	+	+	+	+	+	A	+	+	+	+	+	+	+	+	+
Intestine small, duodenum	+	+	+	+	+	+	+	+	+	+	+	+	+	+	+	A	+	+	+	+	+	+	+	+	+
Intestine small, jejunum	+	+	A	+	+	+	+	A	+	+	+	+	+	+	+	A	+	A	+	+	+	+	+	+	+
Intestine small, ileum	+	+	A	A	+	+	+	+	+	+	+	+	+	+	+	A	+	A	+	+	+	+	+	+	+
Liver	+	+	+	+	+	+	+	+	+	+	+	+	+	+	+	+	+	+	+	+	+	+	+	+	+
Hepatocellular adenoma																									X
Mesentery				+												+							+	+	
Pancreas	+	+	+	+	+	+	+	+	+	+	+	+	+	+	+	+	+	+	+	+	+	+	+	+	+
Pharynx																									
Squamous cell papilloma																									
Salivary glands	+	+	+	+	+	+	+	+	+	+	+	+	+	+	+	+	+	+	+	+	+	+	+	+	+
Stomach, forestomach	+	+	+	+	+	+	+	+	+	+	+	+	+	+	+	+	+	+	+	+	+	+	+	+	+
Stomach, glandular	+		+	+	+	+	+	+	+	+	+	+	+	+	+	+	+	+	+	+	+	+	+	+	+
Tongue																									
Squamous cell carcinoma																									
Tooth																									
<b>Cardiovascular System</b>																									
Blood vessel	+	+	+	+	+	+	+	+	+	+	+	+	+	+	+	+	+	+	+	M	+	+	+	+	+
Heart	+	+	+	+	+	+	+	+	+	+	+	+	+	+	+	+	+	+	+	+	+	+	+	+	+
<b>Endocrine System</b>																									
Adrenal cortex	+	+	+	+	+	+	+	+	+	+	+	+	+	+	+	+	+	+	+	+	+	+	+	+	+
Adrenal medulla	+	+	+	+	+	+	+	+	+	+	+	+	+	+	+	+	+	+	M	+	+	+	+	+	+
Pheochromocytoma malignant																									X
Pheochromocytoma benign																									X
Bilateral, pheochromocytoma benign																									X
Islets, pancreatic	+	+	+	+	+	+	+	+	+	+	+	+	+	+	+	+	+	+	+	+	+	+	+	+	+
Adenoma																									X
Parathyroid gland	+	+	+	+	+	+	+	+	+	+	+	+	+	+	+	+	+	+	+	+	+	+	+	+	+
Pituitary gland	+	+	+	+	+	+	+	+	+	+	+	+	+	+	+	+	+	+	+	I	+	+	+	+	+
Pars distalis, adenoma	X			X	X			X	X	X						X				X			X	X	
Thyroid gland	+	+	+	+	+	+	+	+	+	+	+	+	+	+	+	+	+	+	+	+	+	+	+	+	+
C-cell, adenoma																									X
C-cell, carcinoma																									
Follicular cell, adenoma																									
<b>General Body System</b>																									
None																									
<b>Genital System</b>																									
Epididymis	+	+	+	+	+	+	+	+	+	+	+	+	+	+	+	+	+	+	+	+	+	+	+	+	+
Preputial gland	+	+	+	+	+	+	+	+	+	+	+	+	+	+	+	+	+	+	+	+	+	+	+	+	+
Carcinoma																									X
Prostate	+	+	+	+	+	+	+	+	+	+	+	+	+	+	+	+	+	+	+	+	+	+	+	+	+
Seminal vesicle	+	+	+	+	+	+	+	+	+	+	+	+	+	+	+	+	+	+	+	+	+	+	+	+	+
Testes	+	+	+	+	+	+	+	+	+	+	+	+	+	+	+	+	+	+	+	+	+	+	+	+	+
Bilateral, interstitial cell, adenoma				X			X	X					X	X	X							X	X	X	X
Interstitial cell, adenoma			X					X	X				X									X			



**TABLE A2**  
**Individual Animal Tumor Pathology of Male Rats in the 2-Year Inhalation Study of Acetonitrile: 100 ppm (continued)**

Number of Days on Study	6 6 6 6 7 7 7 7 7 7 7 7 7 7 7 7 7 7 7 7 7																				Total Tissues/ Tumors
	6 8 8 9 0 0 1 2 2 3 3 3 3 3 3 3 3 3 3 3 3																				
	5 8 9 3 1 7 8 1 3 2 3 3 3 3 3 3 3 3 3 3 3																				
Carcass ID Number	1 1																				
	5 3 4 1 4 4 3 4 5 5 1 1 2 2 2 2 3 4 5 5 5																				
	5 1 6 5 3 7 2 8 2 8 4 8 0 1 2 9 4 1 0 3 4																				
<b>Alimentary System</b>																					
Esophagus	+ +																				47
Intestine large, colon	+ + A +																				42
Intestine large, rectum	+ + A +																				44
Intestine large, cecum	+ + A +																				43
Intestine small, duodenum	+ + A +																				45
Intestine small, jejunum	+ + A +																				42
Intestine small, ileum	+ + A +																				42
Liver	+ +																				47
Hepatocellular adenoma																					1
Mesentery	+                                +   +   +                                +																				9
Pancreas	+ +																				47
Pharynx	+ +																				1
Squamous cell papilloma																					1
Salivary glands	+ +																				47
Stomach, forestomach	+ +																				47
Stomach, glandular	+ +																				46
Tongue	+ +																				2
Squamous cell carcinoma																					1
Tooth																					
<b>Cardiovascular System</b>																					
Blood vessel	+ +																				46
Heart	+ +																				47
<b>Endocrine System</b>																					
Adrenal cortex	+ +																				47
Adrenal medulla	+ +																				46
Pheochromocytoma malignant																					1
Pheochromocytoma benign	X                                X X X                                X																				10
Bilateral, pheochromocytoma benign	X                                X                                X                                X																				4
Islets, pancreatic	+ +																				47
Adenoma	+ +																				4
Parathyroid gland	+ +																				46
Pituitary gland	+ +																				46
Pars distalis, adenoma	X X    X X X X X X    X X    X X X X    X    X X X																				27
Thyroid gland	+ +																				47
C-cell, adenoma	X                                X                                X                                X																				5
C-cell, carcinoma																					1
Follicular cell, adenoma																					1
<b>General Body System</b>																					
None																					
<b>Genital System</b>																					
Epididymis	+ +																				47
Preputial gland	+ +																				47
Carcinoma																					1
Prostate	+ +																				47
Seminal vesicle	+ M +																				46
Testes	+ +																				47
Bilateral, interstitial cell, adenoma	X    X X X X X    X X X X X X X X X X X X X X X X X X																				29
Interstitial cell, adenoma																					6







TABLE A2

Individual Animal Tumor Pathology of Male Rats in the 2-Year Inhalation Study of Acetonitrile: 200 ppm (continued)

Number of Days on Study	6 6 6 6 6 6 6 6 7 7 7 7 7 7 7 7 7 7 7 7		Total Tissues/ Tumors
	6 6 7 7 8 8 9 9 0 0 0 0 0 1 3 3 3 3 3 3 3 3		
	5 6 3 4 4 4 1 8 0 5 7 7 9 9 3 3 3 3 3 3 3 3		
Carcass ID Number	2 2		
	5 7 8 5 4 7 5 3 6 6 4 5 5 3 3 4 4 4 4 4 6 7 7 7		
	1 1 0 7 7 6 0 7 7 6 3 2 4 8 4 0 1 6 8 8 0 3 5		
<b>Alimentary System</b>			
Esophagus	+	+	48
Intestine large, colon	+	A	46
Intestine large, rectum	+	A	47
Intestine large, cecum	+	A	46
Intestine small, duodenum	+	+	48
Intestine small, jejunum	+	A	46
Intestine small, ileum	+	A	46
Liver	+	+	48
Hepatocellular adenoma	X		1
Osteosarcoma, metastatic, bone			1
Mesentery	+	+	9
Pancreas	+	+	48
Salivary glands	+	+	48
Stomach, forestomach	+	+	48
Stomach, glandular	+	+	48
<b>Cardiovascular System</b>			
Blood vessel	+	+	48
Heart	+	+	48
<b>Endocrine System</b>			
Adrenal cortex	+	+	48
Adrenal medulla	+	+	48
Pheochromocytoma malignant			2
Pheochromocytoma benign		X X X	10
Bilateral, pheochromocytoma benign		X	2
Islets, pancreatic	+	+	48
Adenoma		X X	4
Adenoma, multiple			1
Carcinoma	X		3
Parathyroid gland	+	+	46
Pituitary gland	+	+	48
Pars distalis, adenoma	X	X X X	23
Thyroid gland	+	+	48
Bilateral, C-cell, adenoma			1
C-cell, adenoma	X	X	6
Follicular cell, carcinoma		X	1
<b>General Body System</b>			
None			
<b>Genital System</b>			
Epididymis	+	+	48
Preputial gland	+	M	47
Adenoma			1
Carcinoma	X X		2
Prostate	+	+	48
Seminal vesicle	+	+	48
Testes	+	+	48
Osteosarcoma, metastatic, bone			1
Bilateral, interstitial cell, adenoma	X X X X	X X X X X X X X X X	30
Interstitial cell, adenoma		X X	10



**TABLE A2**  
**Individual Animal Tumor Pathology of Male Rats in the 2-Year Inhalation Study of Acetonitrile: 200 ppm (continued)**

Number of Days on Study	6	6	6	6	6	6	6	6	7	7	7	7	7	7	7	7	7	7	7	7	7	7	7	Total Tissues/ Tumors
Carcass ID Number	5	7	8	5	4	7	5	3	6	6	4	5	5	3	3	4	4	4	4	6	7	7	7	
	1	1	0	7	7	6	0	7	7	6	3	2	4	8	4	0	1	6	8	8	0	3	5	
<b>Hematopoietic System</b>																								
Bone marrow	+	+	+	+	+	+	+	+	+	+	+	+	+	+	+	+	+	+	+	+	+	+	+	48
Lymph node	+							+	+					+										13
Axillary, osteosarcoma, metastatic, bone																								1
Lymph node, bronchial	+	+	+	+	+	M	+	+	+	+	+	+	+	+	M	+	+	+	+	+	+	M	M	40
Osteosarcoma, metastatic, bone																								1
Lymph node, mandibular	+	+	M	+	+	+	+	+	+	+	+	+	+	+	+	+	+	+	+	+	+	+	+	45
Lymph node, mesenteric	+	+	+	+	+	+	+	+	+	M	+	+	+	+	+	+	+	+	+	+	+	+	+	47
Lymph node, mediastinal	+	+	+	+	+	+	+	+	+	+	+	+	+	+	+	+	+	+	+	+	+	+	+	48
Spleen	+	+	+	+	+	+	+	+	+	+	+	+	+	+	+	+	+	+	+	+	+	+	+	48
Osteosarcoma, metastatic, bone																								1
Thymus	+	+	+	+	+	+	+	+	+	+	+	+	+	+	+	+	+	+	+	+	+	M	+	47
Thymoma NOS																						X		1
<b>Integumentary System</b>																								
Mammary gland	+	+	+	+	+	+	+	+	+	+	+	+	+	+	+	+	+	+	+	+	+	+	+	48
Carcinoma			X																					1
Skin	+	+	+	+	+	+	+	+	+	+	+	+	+	+	+	+	+	+	+	+	+	+	+	48
Fibroma, multiple														X										1
Hemangiopericytoma														X										1
Trichoepithelioma			X																					1
<b>Musculoskeletal System</b>																								
Bone	+	+	+	+	+	+	+	+	+	+	+	+	+	+	+	+	+	+	+	+	+	+	+	48
Humerus, osteosarcoma																								1
<b>Nervous System</b>																								
Brain	+	+	+	+	+	+	+	+	+	+	+	+	+	+	+	+	+	+	+	+	+	+	+	48
Meninges, meningioma benign																						X		1
<b>Respiratory System</b>																								
Larynx	+	+	+	+	+	+	+	+	+	+	+	+	+	+	+	+	+	+	+	+	+	+	+	48
Lung	+	+	+	+	+	+	+	+	+	+	+	+	+	+	+	+	+	+	+	+	+	+	+	48
Alveolar/bronchiolar carcinoma																								1
Osteosarcoma, metastatic, bone																								1
Nose	+	+	+	+	+	+	+	+	+	+	+	+	+	+	+	+	+	+	+	+	+	+	+	48
Trachea	+	+	+	+	+	+	+	+	+	+	+	+	+	+	+	+	+	+	+	+	+	+	+	48
<b>Special Senses System</b>																								
Eye																						+		2
<b>Urinary System</b>																								
Kidney	+	+	+	+	+	+	+	+	+	+	+	+	+	+	+	+	+	+	+	+	+	+	+	48
Urinary bladder	+	+	+	+	+	+	+	+	+	+	+	+	+	+	+	+	+	+	+	+	+	+	+	48
Transitional epithelium, carcinoma																								1
<b>Systemic Lesions</b>																								
Multiple organs	+	+	+	+	+	+	+	+	+	+	+	+	+	+	+	+	+	+	+	+	+	+	+	48
Leukemia mononuclear		X	X	X	X	X	X	X	X	X	X	X	X	X	X	X	X	X	X	X	X	X	X	35
Mesothelioma NOS			X																			X		2

**TABLE A2**  
**Individual Animal Tumor Pathology of Male Rats in the 2-Year Inhalation Study of Acetonitrile: 400 ppm**

Number of Days on Study	4 4 5 5 5 5 5 5 5 5 6 6 6 6 6 6 6 6 6 6 6 6 6 6 6
	8 8 4 6 6 7 8 8 8 9 2 2 3 4 4 5 5 6 7 7 7 7 9 9 9
	3 5 7 0 7 6 6 8 8 7 3 8 2 1 9 0 2 5 2 2 9 9 1 2 2
Carcass ID Number	3 3
	5 7 7 7 8 8 8 4 9 8 4 5 6 6 6 4 8 5 5 8 7 8 4 6 9
	7 0 3 4 5 7 9 0 2 3 1 0 0 1 5 3 6 8 4 8 5 1 6 9 0
<b>Alimentary System</b>	
Esophagus	+ +
Intestine large, colon	+ + + + + + + + + + + A + + A + + + + + + + + + + A
Intestine large, rectum	+ + + + + + A + + + + A + + + + + + + + + + + + + +
Intestine large, cecum	+ + A + + + + + + + + A + + A + + + + + + + + + + A
Intestine small, duodenum	+ A
Intestine small, jejunum	+ + + + + + A + + + + A + + A + + + + + + + + + + A
Carcinoma	X
Intestine small, ileum	+ + A + + + A + + + + A + + A + + + + + + + + + + A
Liver	+ +
Hepatocellular carcinoma	
Hepatocellular carcinoma, multiple	
Hepatocellular adenoma	
Mesentery	
+	
Pancreas	+ +
Adenoma	
Pharynx	
Squamous cell papilloma	
Salivary glands	+ +
Stomach, forestomach	+ +
Stomach, glandular	+ +
Tongue	
Squamous cell carcinoma	
Tooth	
<b>Cardiovascular System</b>	
Blood vessel	+ +
Heart	+ +
<b>Endocrine System</b>	
Adrenal cortex	+ +
Adrenal medulla	+ +
Pheochromocytoma malignant	
Pheochromocytoma benign	
Bilateral, pheochromocytoma benign	X X X X X X
Islets, pancreatic	+ +
Adenoma	
Carcinoma	
Parathyroid gland	+ + + + + + + + + + M M + + + + + + + + + + + + + +
Pituitary gland	+ + + + + + + + + + + I + + + + + + + + + + + + + +
Pars distalis, adenoma	X X
Thyroid gland	+ +
Bilateral, C-cell, carcinoma	
C-cell, adenoma	X X
<b>General Body System</b>	
None	











**TABLE A2**  
**Individual Animal Tumor Pathology of Male Rats in the 2-Year Inhalation Study of Acetonitrile: 400 ppm (continued)**

<b>Number of Days on Study</b>	6 7	
	9 1 2 2 2 2 3 3 3 3 3 3 3 3 3 3 3 3 3 3 3 3	
	3 6 3 7 7 7 3 3 3 3 3 3 3 3 3 3 3 3 3 3 3 3	
<b>Carcass ID Number</b>	3 3	Total
	7 4 7 4 8 8 3 3 4 4 4 5 5 6 6 6 6 6 7 7 7 7 8	Tissues/
	6 4 7 7 0 4 7 9 5 8 9 3 9 2 3 4 6 8 1 2 8 9 2	Tumors
<b>Special Senses System</b>		
Eye		2
Lacrimal gland	+	1
Zymbal's gland		1
Carcinoma		1
<b>Urinary System</b>		
Kidney	+ +	48
Urinary bladder	+ +	48
<b>Systemic Lesions</b>		
Multiple organs	+ +	48
Leukemia mononuclear	X X	32
Mesothelioma NOS	X	1

**TABLE A3**  
**Statistical Analysis of Primary Neoplasms in Male Rats in the 2-Year Inhalation Study of Acetonitrile**

	0 ppm	100 ppm	200 ppm	400 ppm
<b>Adrenal Medulla: Benign Pheochromocytoma</b>				
Overall rate <sup>a</sup>	4/48 (8%)	14/46 (30%)	12/48 (25%)	7/48 (15%)
Adjusted rate <sup>b</sup>	25.0%	56.0%	52.1%	22.1%
Terminal rate <sup>c</sup>	2/11 (18%)	3/13 (23%)	2/9 (22%)	0/17 (0%)
First incidence (days)	646	588	507	632
Life table test <sup>d</sup>	P=0.335N	P=0.025	P=0.025	P=0.441
Logistic regression test <sup>d</sup>	P=0.480N	P=0.002	P=0.022	P=0.244
Cochran-Armitage test <sup>d</sup>	P=0.502			
Fisher exact test <sup>d</sup>		P=0.006	P=0.026	P=0.262
<b>Adrenal Medulla: Benign or Malignant Pheochromocytoma</b>				
Overall rate	4/48 (8%)	15/46 (33%)	14/48 (29%)	8/48 (17%)
Adjusted rate	25.0%	57.1%	55.0%	26.2%
Terminal rate	2/11 (18%)	3/13 (23%)	2/9 (22%)	0/17 (0%)
First incidence (days)	646	559	507	632
Life table test	P=0.396N	P=0.016	P=0.010	P=0.358
Logistic regression test	P=0.518	P=0.003	P=0.008	P=0.173
Cochran-Armitage test	P=0.410			
Fisher exact test		P=0.003	P=0.008	P=0.178
<b>Liver: Hepatocellular Adenoma</b>				
Overall rate	0/48 (0%)	1/47 (2%)	1/48 (2%)	3/48 (6%)
Adjusted rate	0.0%	3.4%	4.8%	16.2%
Terminal rate	0/11 (0%)	0/13 (0%)	0/9 (0%)	2/17 (12%)
First incidence (days)	- <sup>e</sup>	623	673	727
Life table test	P=0.110	P=0.480	P=0.465	P=0.214
Logistic regression test	P=0.083	P=0.495	P=0.492	P=0.204
Cochran-Armitage test	P=0.055			
Fisher exact test		P=0.495	P=0.500	P=0.121
<b>Liver: Hepatocellular Carcinoma</b>				
Overall rate	1/48 (2%)	0/47 (0%)	0/48 (0%)	3/48 (6%)
Adjusted rate	3.3%	0.0%	0.0%	14.5%
Terminal rate	0/11 (0%)	0/13 (0%)	0/9 (0%)	1/17 (6%)
First incidence (days)	637	-	-	693
Life table test	P=0.150	P=0.514N	P=0.514N	P=0.438
Logistic regression test	P=0.121	P=0.504N	P=0.500N	P=0.374
Cochran-Armitage test	P=0.087			
Fisher exact test		P=0.505N	P=0.500N	P=0.308
<b>Liver: Hepatocellular Adenoma or Carcinoma</b>				
Overall rate	1/48 (2%)	1/47 (2%)	1/48 (2%)	5/48 (10%)
Adjusted rate	3.3%	3.4%	4.8%	25.2%
Terminal rate	0/11 (0%)	0/13 (0%)	0/9 (0%)	3/17 (18%)
First incidence (days)	637	623	673	693
Life table test	P=0.067	P=0.742	P=0.733	P=0.213
Logistic regression test	P=0.045	P=0.757	P=0.758	P=0.164
Cochran-Armitage test	P=0.026			
Fisher exact test		P=0.747	P=0.753N	P=0.102

**TABLE A3**  
**Statistical Analysis of Primary Neoplasms in Male Rats in the 2-Year Inhalation Study of Acetonitrile** (continued)

	0 ppm	100 ppm	200 ppm	400 ppm
<b>Mammary Gland: Fibroadenoma or Carcinoma</b>				
Overall rate	0/48 (0%)	2/47 (4%)	1/48 (2%)	3/48 (6%)
Adjusted rate	0.0%	15.4%	4.5%	16.2%
Terminal rate	0/11 (0%)	2/13 (15%)	0/9 (0%)	2/17 (12%)
First incidence (days)	–	733 (T)	666	727
Life table test	P=0.202	P=0.273	P=0.474	P=0.214
Logistic regression test	P=0.178	P=0.273	P=0.493	P=0.204
Cochran-Armitage test	P=0.105			
Fisher exact test		P=0.242	P=0.500	P=0.121
<b>Pancreatic Islets: Adenoma</b>				
Overall rate	1/48 (2%)	4/47 (9%)	5/48 (10%)	1/48 (2%)
Adjusted rate	3.6%	18.9%	22.8%	5.9%
Terminal rate	0/11 (0%)	1/13 (8%)	0/9 (0%)	1/17 (6%)
First incidence (days)	651	559	539	733 (T)
Life table test	P=0.357N	P=0.196	P=0.090	P=0.697N
Logistic regression test	P=0.438N	P=0.174	P=0.098	P=0.727N
Cochran-Armitage test	P=0.476N			
Fisher exact test		P=0.174	P=0.102	P=0.753N
<b>Pancreatic Islets: Carcinoma</b>				
Overall rate	1/48 (2%)	0/47 (0%)	3/48 (6%)	1/48 (2%)
Adjusted rate	5.9%	0.0%	9.8%	5.9%
Terminal rate	0/11 (0%)	0/13 (0%)	0/9 (0%)	1/17 (6%)
First incidence (days)	693	–	560	733 (T)
Life table test	P=0.555	P=0.468N	P=0.295	P=0.676N
Logistic regression test	P=0.483	P=0.498N	P=0.305	P=0.702N
Cochran-Armitage test	P=0.472			
Fisher exact test		P=0.505N	P=0.308	P=0.753N
<b>Pancreatic Islets: Adenoma or Carcinoma</b>				
Overall rate	2/48 (4%)	4/47 (9%)	8/48 (17%)	2/48 (4%)
Adjusted rate	9.2%	18.9%	30.4%	11.8%
Terminal rate	0/11 (0%)	1/13 (8%)	0/9 (0%)	2/17 (12%)
First incidence (days)	651	559	539	733 (T)
Life table test	P=0.413N	P=0.367	P=0.045	P=0.572N
Logistic regression test	P=0.527N	P=0.330	P=0.045	P=0.616N
Cochran-Armitage test	P=0.566N			
Fisher exact test		P=0.329	P=0.045	P=0.692N
<b>Pituitary Gland (Pars Distalis): Adenoma</b>				
Overall rate	25/48 (52%)	27/46 (59%)	23/48 (48%)	23/47 (49%)
Adjusted rate	72.1%	88.5%	82.8%	68.2%
Terminal rate	4/11 (36%)	10/13 (77%)	6/9 (67%)	8/17 (47%)
First incidence (days)	394	331	371	485
Life table test	P=0.073N	P=0.540	P=0.543	P=0.129N
Logistic regression test	P=0.284N	P=0.335	P=0.412N	P=0.487N
Cochran-Armitage test	P=0.308N			
Fisher exact test		P=0.331	P=0.419N	P=0.460N

**TABLE A3**  
**Statistical Analysis of Primary Neoplasms in Male Rats in the 2-Year Inhalation Study of Acetonitrile** (continued)

	0 ppm	100 ppm	200 ppm	400 ppm
<b>Preputial Gland: Carcinoma</b>				
Overall rate	5/47 (11%)	1/47 (2%)	2/47 (4%)	1/48 (2%)
Adjusted rate	15.8%	2.9%	8.7%	2.1%
Terminal rate	0/11 (0%)	0/13 (0%)	0/9 (0%)	0/17 (0%)
First incidence (days)	472	567	665	485
Life table test	P=0.075N	P=0.112N	P=0.257N	P=0.081N
Logistic regression test	P=0.113N	P=0.089N	P=0.195N	P=0.201N
Cochran-Armitage test	P=0.089N			
Fisher exact test		P=0.102N	P=0.217N	P=0.097N
<b>Preputial Gland: Adenoma or Carcinoma</b>				
Overall rate	5/47 (11%)	1/47 (2%)	3/47 (6%)	1/48 (2%)
Adjusted rate	15.8%	2.9%	18.8%	2.1%
Terminal rate	0/11 (0%)	0/13 (0%)	1/9 (11%)	0/17 (0%)
First incidence (days)	472	567	665	485
Life table test	P=0.087N	P=0.112N	P=0.413N	P=0.081N
Logistic regression test	P=0.133N	P=0.089N	P=0.345N	P=0.201N
Cochran-Armitage test	P=0.109N			
Fisher exact test		P=0.102N	P=0.357N	P=0.097N
<b>Skin: Fibroma</b>				
Overall rate	3/48 (6%)	2/47 (4%)	1/48 (2%)	3/48 (6%)
Adjusted rate	17.3%	12.6%	7.7%	10.4%
Terminal rate	1/11 (9%)	1/13 (8%)	0/9 (0%)	0/17 (0%)
First incidence (days)	602	701	707	560
Life table test	P=0.471N	P=0.448N	P=0.347N	P=0.527N
Logistic regression test	P=0.544N	P=0.497N	P=0.325N	P=0.642N
Cochran-Armitage test	P=0.572			
Fisher exact test		P=0.510N	P=0.308N	P=0.661N
<b>Skin: Fibroma or Fibrosarcoma</b>				
Overall rate	3/48 (6%)	3/47 (6%)	1/48 (2%)	3/48 (6%)
Adjusted rate	17.3%	19.8%	7.7%	10.4%
Terminal rate	1/11 (9%)	2/13 (15%)	0/9 (0%)	0/17 (0%)
First incidence (days)	602	701	707	560
Life table test	P=0.394N	P=0.603N	P=0.347N	P=0.527N
Logistic regression test	P=0.461N	P=0.659N	P=0.325N	P=0.642N
Cochran-Armitage test	P=0.540N			
Fisher exact test		P=0.651	P=0.308N	P=0.661N
<b>Skin: Keratoacanthoma</b>				
Overall rate	0/48 (0%)	1/47 (2%)	0/48 (0%)	4/48 (8%)
Adjusted rate	0.0%	5.9%	0.0%	23.5%
Terminal rate	0/11 (0%)	0/13 (0%)	0/9 (0%)	4/17 (24%)
First incidence (days)	-	718	-	733 (T)
Life table test	P=0.039	P=0.553	-	P=0.122
Logistic regression test	P=0.036	P=0.516	-	P=0.122
Cochran-Armitage test	P=0.014			
Fisher exact test		P=0.495	-	P=0.059



**TABLE A3**  
**Statistical Analysis of Primary Neoplasms in Male Rats in the 2-Year Inhalation Study of Acetonitrile** (continued)

	0 ppm	100 ppm	200 ppm	400 ppm
<b>Skin: Keratoacanthoma, Trichoepithelioma, or Basal Cell Adenoma</b>				
Overall rate	0/48 (0%)	2/47 (4%)	1/48 (2%)	5/48 (10%)
Adjusted rate	0.0%	13.1%	4.5%	27.4%
Terminal rate	0/11 (0%)	1/13 (8%)	0/9 (0%)	4/17 (24%)
First incidence (days)	–	718	666	727
Life table test	P=0.049	P=0.289	P=0.474	P=0.082
Logistic regression test	P=0.037	P=0.265	P=0.493	P=0.077
Cochran-Armitage test	P=0.014			
Fisher exact test		P=0.242	P=0.500	P=0.028
<b>Testes: Adenoma</b>				
Overall rate	33/48 (69%)	35/47 (74%)	40/48 (83%)	42/48 (88%)
Adjusted rate	96.9%	100.0%	100.0%	100.0%
Terminal rate	10/11 (91%)	13/13 (100%)	9/9 (100%)	17/17 (100%)
First incidence (days)	492	446	395	483
Life table test	P=0.408N	P=0.492N	P=0.086	P=0.403N
Logistic regression test	P=0.055	P=0.347	P=0.025	P=0.120
Cochran-Armitage test	P=0.012			
Fisher exact test		P=0.348	P=0.075	P=0.023
<b>Thyroid Gland (C-cell): Adenoma</b>				
Overall rate	6/48 (13%)	5/47 (11%)	7/48 (15%)	6/48 (13%)
Adjusted rate	31.1%	25.5%	35.8%	27.3%
Terminal rate	2/11 (18%)	2/13 (15%)	2/9 (22%)	3/17 (18%)
First incidence (days)	646	525	573	672
Life table test	P=0.382N	P=0.432N	P=0.415	P=0.379N
Logistic regression test	P=0.497N	P=0.504N	P=0.471	P=0.474N
Cochran-Armitage test	P=0.506			
Fisher exact test		P=0.515N	P=0.500	P=0.621N
<b>Thyroid Gland (C-cell): Carcinoma</b>				
Overall rate	3/48 (6%)	1/47 (2%)	0/48 (0%)	1/48 (2%)
Adjusted rate	10.7%	7.7%	0.0%	5.9%
Terminal rate	0/11 (0%)	1/13 (8%)	0/9 (0%)	1/17 (6%)
First incidence (days)	511	733 (T)	–	733 (T)
Life table test	P=0.161N	P=0.299N	P=0.150N	P=0.239N
Logistic regression test	P=0.180N	P=0.311N	P=0.118N	P=0.308N
Cochran-Armitage test	P=0.198N			
Fisher exact test		P=0.316N	P=0.121N	P=0.308N
<b>Thyroid Gland (C-cell): Adenoma or Carcinoma</b>				
Overall rate	9/48 (19%)	6/47 (13%)	7/48 (15%)	7/48 (15%)
Adjusted rate	38.4%	32.3%	35.8%	32.5%
Terminal rate	2/11 (18%)	3/13 (23%)	2/9 (22%)	4/17 (24%)
First incidence (days)	511	525	573	672
Life table test	P=0.204N	P=0.244N	P=0.496N	P=0.184N
Logistic regression test	P=0.291N	P=0.292N	P=0.414N	P=0.270N
Cochran-Armitage test	P=0.400N			
Fisher exact test		P=0.303N	P=0.392N	P=0.392N

**TABLE A3**  
**Statistical Analysis of Primary Neoplasms in Male Rats in the 2-Year Inhalation Study of Acetonitrile (continued)**

	0 ppm	100 ppm	200 ppm	400 ppm
<b>All Organs: Mononuclear Cell Leukemia</b>				
Overall rate	29/48 (60%)	32/47 (68%)	35/48 (73%)	32/48 (67%)
Adjusted rate	85.4%	85.4%	85.4%	85.6%
Terminal rate	7/11 (64%)	8/13 (62%)	4/9 (44%)	12/17 (71%)
First incidence (days)	418	530	442	547
Life table test	P=0.214N	P=0.485	P=0.142	P=0.231N
Logistic regression test	P=0.423	P=0.289	P=0.134	P=0.493
Cochran-Armitage test	P=0.320			
Fisher exact test		P=0.286	P=0.139	P=0.336
<b>All Organs: Mesothelioma NOS</b>				
Overall rate	3/48 (6%)	5/47 (11%)	2/48 (4%)	1/48 (2%)
Adjusted rate	7.4%	26.8%	15.3%	5.9%
Terminal rate	0/11 (0%)	2/13 (15%)	1/9 (11%)	1/17 (6%)
First incidence (days)	492	639	673	733 (T)
Life table test	P=0.087N	P=0.384	P=0.545N	P=0.250N
Logistic regression test	P=0.121N	P=0.344	P=0.486N	P=0.441N
Cochran-Armitage test	P=0.134N			
Fisher exact test		P=0.345	P=0.500N	P=0.308N
<b>All Organs: Benign Neoplasms</b>				
Overall rate	45/48 (94%)	45/47 (96%)	45/48 (94%)	47/48 (98%)
Adjusted rate	100.0%	100.0%	100.0%	100.0%
Terminal rate	11/11 (100%)	13/13 (100%)	9/9 (100%)	17/17 (100%)
First incidence (days)	394	331	371	483
Life table test	P=0.101N	P=0.411N	P=0.329	P=0.105N
Logistic regression test	P=0.490	P=0.514	P=0.606	P=0.675
Cochran-Armitage test	P=0.260			
Fisher exact test		P=0.510	P=0.661N	P=0.308
<b>All Organs: Malignant Neoplasms</b>				
Overall rate	36/48 (75%)	35/47 (74%)	38/48 (79%)	34/48 (71%)
Adjusted rate	88.6%	89.5%	86.7%	86.5%
Terminal rate	7/11 (64%)	9/13 (69%)	4/9 (44%)	12/17 (71%)
First incidence (days)	418	530	371	485
Life table test	P=0.084N	P=0.402N	P=0.293	P=0.076N
Logistic regression test	P=0.327N	P=0.564N	P=0.423	P=0.360N
Cochran-Armitage test	P=0.376N			
Fisher exact test		P=0.570N	P=0.404	P=0.409N

**TABLE A3**  
**Statistical Analysis of Primary Neoplasms in Male Rats in the 2-Year Inhalation Study of Acetonitrile** (continued)

	0 ppm	100 ppm	200 ppm	400 ppm
<b>All Organs: Benign or Malignant Neoplasms</b>				
Overall rate	48/48 (100%)	47/47 (100%)	48/48 (100%)	48/48 (100%)
Adjusted rate	100.0%	100.0%	100.0%	100.0%
Terminal rate	11/11 (100%)	13/13 (100%)	9/9 (100%)	17/17 (100%)
First incidence (days)	394	331	371	483
Life table test	P=0.071N	P=0.373N	P=0.333	P=0.069N
Logistic regression test	- <sup>f</sup>	-	-	-
Cochran-Armitage test	-			
Fisher exact test		P=1.000N	P=1.000N	P=1.000N

(T) Terminal sacrifice

<sup>a</sup> Number of neoplasm-bearing animals/number of animals examined. Denominator is number of animals examined microscopically for adrenal gland, liver, pancreatic islets, pituitary gland, preputial gland, testes, and thyroid gland; for other tissues, denominator is number of animals necropsied.

<sup>b</sup> Kaplan-Meier estimated neoplasm incidence at the end of the study after adjustment for intercurrent mortality

<sup>c</sup> Observed incidence at terminal kill

<sup>d</sup> Beneath the control incidence are the P values associated with the trend test. Beneath the exposed group incidence are the P values corresponding to pairwise comparisons between the controls and that exposed group. The life table test regards neoplasms in animals dying prior to terminal kill as being (directly or indirectly) the cause of death. The logistic regression test regards these lesions as nonfatal. The Cochran-Armitage and Fisher exact tests compare directly the overall incidence rates. For all tests, a negative trend or a lower incidence in an exposure group is indicated by N.

<sup>e</sup> Not applicable; no neoplasms in animal group

<sup>f</sup> Value of statistic cannot be computed.

**TABLE A4a**  
**Historical Incidence of Hepatocellular Neoplasms in Untreated Male F344/N Rats<sup>a</sup>**

Study	Incidence in Controls		
	Adenoma	Carcinoma	Adenoma or Carcinoma
<b>Historical Incidence at Battelle Pacific Northwest Laboratories</b>			
<i>o</i> -Chlorobenzalmononitrile (CS2)	2/50	2/50	4/50
2-Chloroacetophenone	1/49	0/49	1/49
<i>l</i> -Epinephrine Hydrochloride	1/50	0/50	1/50
Chloroethane	0/50	1/50	1/50
Hexachlorocyclopentadiene	1/50	0/50	1/50
<b>Overall Historical Incidence</b>			
Total	11/398 (2.8%)	4/398 (1.0%)	15/398 (3.8%)
Standard deviation	2.6%	1.5%	2.7%
Range	0%-8%	0%-4%	2%-8%

<sup>a</sup> Data as of 31 March 1993

**TABLE A4b**  
**Historical Incidence of Adrenal Gland Pheochromocytomas in Untreated Male F344/N Rats<sup>a</sup>**

Study	Incidence in Controls		
	Benign	Malignant	Benign, Malignant, Complex, or NOS
<b>Historical Incidence at Battelle Pacific Northwest Laboratories</b>			
<i>o</i> -Chlorobenzalmononitrile (CS2)	18/42	4/42	20/42
2-Chloroacetophenone	14/46	2/46	15/46
<i>l</i> -Epinephrine Hydrochloride	11/50	0/50	11/50
Chloroethane	8/36	0/36	8/36
Hexachlorocyclopentadiene	15/50	2/50	16/50
<b>Overall Historical Incidence</b>			
Total	92/368 (25.0%)	10/368 (2.7%)	107/368 (29.1%)
Standard deviation	12.2%	3.4%	10.3%
Range	0%-43%	0%-10%	14%-48%

<sup>a</sup> Data as of 31 March 1993

**TABLE A4c**  
**Historical Incidence of Pancreatic Islet Neoplasms in Untreated Male F344/N Rats<sup>a</sup>**

Study	Incidence in Controls		
	Adenoma	Carcinoma	Adenoma or Carcinoma
<b>Historical Incidence at Battelle Pacific Northwest Laboratories</b>			
<i>o</i> -Chlorobenzalmononitrile (CS2)	1/50	0/50	1/50
2-Chloroacetophenone	3/47	1/47	4/47
<i>l</i> -Epinephrine Hydrochloride	5/50	1/50	6/50
Chloroethane	6/48	0/48	6/48
Hexachlorocyclopentadiene	7/50	4/50	11/50
<b>Overall Historical Incidence</b>			
Total	33/390 (8.5%)	12/390 (3.1%)	45/390 (11.5%)
Standard deviation	4.6%	3.9%	6.1%
Range	2%-14%	0%-10%	2%-22%

<sup>a</sup> Data as of 31 March 1993

**TABLE A4d**  
**Historical Incidence of Skin Keratoacanthomas in Untreated Male F344/N Rats<sup>a</sup>**

Study	Incidence in Controls	
	Adenoma	Carcinoma
<b>Historical Incidence at Battelle Pacific Northwest Laboratories</b>		
<i>o</i> -Chlorobenzalmononitrile (CS2)		0/50
2-Chloroacetophenone		4/50
<i>l</i> -Epinephrine Hydrochloride		2/50
Chloroethane		4/50
Hexachlorocyclopentadiene		0/50
<b>Overall Historical Incidence</b>		
Total		14/399 (3.5%)
Standard deviation		3.3%
Range		0%-8%

<sup>a</sup> Data as of 31 March 1993

**TABLE A5**  
**Summary of the Incidence of Nonneoplastic Lesions in Male Rats in the 2-Year Inhalation Study of Acetonitrile<sup>a</sup>**

	0 ppm	100 ppm	200 ppm	400 ppm
<b>Disposition Summary</b>				
Animals initially in study	56	55	56	56
<b>15-Month interim evaluation</b>				
Early deaths	8	8	8	8
Moribund	36	26	35	26
Natural deaths	1	8	4	5
Survivors				
Terminal sacrifice	11	13	9	17
Animals examined microscopically	56	55	56	56
<b>15-Month Interim Evaluation</b>				
<b>Alimentary System</b>				
Intestine large, rectum	(8)	(8)	(8)	(8)
Lumen, parasite metazoan				1 (13%)
Intestine small, jejunum	(8)	(8)	(8)	(8)
Parasite metazoan				1 (13%)
Liver	(8)	(8)	(8)	(8)
Basophilic focus	6 (75%)	6 (75%)	7 (88%)	7 (88%)
Clear cell focus	3 (38%)			2 (25%)
Degeneration, cystic	1 (13%)			
Hepatodiaphragmatic nodule			1 (13%)	
Portal, fibrosis	1 (13%)			
Mesentery				(1)
Fat, inflammation, granulomatous				1 (100%)
Fat, necrosis				1 (100%)
Pancreas	(8)	(8)	(8)	(8)
Acinus, atrophy	3 (38%)	5 (63%)	2 (25%)	2 (25%)
<b>Cardiovascular System</b>				
Blood vessel	(8)	(8)	(8)	(8)
Mineralization	1 (13%)			
Heart	(8)	(8)	(8)	(8)
Cardiomyopathy	5 (63%)	4 (50%)	5 (63%)	4 (50%)
<b>Endocrine System</b>				
Pituitary gland	(8)	(7)	(8)	(7)
Pars distalis, hyperplasia	2 (25%)	4 (57%)	4 (50%)	2 (29%)
Thyroid gland	(8)	(8)	(8)	(8)
Ultimobranchial cyst			2 (25%)	
C-cell, hyperplasia	1 (13%)		2 (25%)	
Follicle, dilatation	1 (13%)			

<sup>a</sup> Number of animals examined microscopically at the site and the number of animals with lesion

TABLE A5

Summary of the Incidence of Nonneoplastic Lesions in Male Rats in the 2-Year Inhalation Study of Acetonitrile  
(continued)

	0 ppm	100 ppm	200 ppm	400 ppm
<b>15-Month Interim Evaluation</b> (continued)				
<b>Genital System</b>				
Preputial gland	(8)	(8)	(8)	(8)
Ectasia	3 (38%)	2 (25%)	5 (63%)	
Granuloma		1 (13%)		
Hyperplasia			1 (13%)	
Inflammation, chronic			4 (50%)	
Inflammation, suppurative	2 (25%)	2 (25%)	1 (13%)	1 (13%)
Prostate	(8)	(8)	(8)	(8)
Inflammation, suppurative	2 (25%)	1 (13%)		
Seminal vesicle	(8)	(8)	(8)	(8)
Inflammation, suppurative		1 (13%)		
Testes	(8)	(8)	(8)	(8)
Germinal epithelium, atrophy				1 (13%)
Interstitial cell, hyperplasia	5 (63%)	7 (88%)	5 (63%)	
<b>Hematopoietic System</b>				
Lymph node		(1)	(2)	(1)
Lumbar, pigmentation		1 (100%)	1 (50%)	1 (100%)
Renal, pigmentation			1 (50%)	
Spleen	(8)	(8)	(8)	(8)
Fibrosis		2 (25%)		1 (13%)
Hyperplasia, RE cell		1 (13%)		
<b>Integumentary System</b>				
Skin	(8)	(8)	(8)	(8)
Acanthosis			1 (13%)	
Inflammation, granulomatous			3 (38%)	
<b>Respiratory System</b>				
Larynx	(8)	(8)	(8)	(8)
Foreign body		1 (13%)		3 (38%)
Inflammation, suppurative	1 (13%)			3 (38%)
Mineralization				1 (13%)
Lung	(8)	(8)	(8)	(8)
Hemorrhage	8 (100%)	8 (100%)	8 (100%)	8 (100%)
Infiltration cellular, histiocyte	3 (38%)	4 (50%)	1 (13%)	2 (25%)
Alveolar epithelium, hyperplasia		4 (50%)	1 (13%)	1 (13%)
Artery, inflammation, chronic active			1 (13%)	
Nose	(8)	(8)	(8)	(8)
Foreign body		1 (13%)		1 (13%)
Hemorrhage		1 (13%)		
Inflammation, chronic				1 (13%)
Respiratory epithelium, hyperplasia				1 (13%)
Trachea	(8)	(8)	(8)	(8)
Peritracheal tissue, fibrosis				1 (13%)
Peritracheal tissue, inflammation, chronic active				1 (13%)

**TABLE A5**  
**Summary of the Incidence of Nonneoplastic Lesions in Male Rats in the 2-Year Inhalation Study of Acetonitrile**  
 (continued)

	0 ppm	100 ppm	200 ppm	400 ppm
<b>15-Month Interim Evaluation</b> (continued)				
<b>Special Senses System</b>				
Eye		(1)		
Cataract		1 (100%)		
<b>Urinary System</b>				
Kidney	(8)	(8)	(8)	(8)
Nephropathy, chronic	7 (88%)	8 (100%)	8 (100%)	8 (100%)
<b>Systems Examined With No Lesions Observed</b>				
<b>General Body System</b>				
<b>Musculoskeletal System</b>				
<b>Nervous System</b>				
<b>2-Year Study</b>				
<b>Alimentary System</b>				
Intestine large, colon	(48)	(42)	(46)	(45)
Lumen, parasite metazoan	4 (8%)	2 (5%)	4 (9%)	1 (2%)
Intestine large, rectum	(47)	(44)	(47)	(46)
Lumen, parasite metazoan	4 (9%)	4 (9%)	6 (13%)	4 (9%)
Intestine large, cecum	(47)	(43)	(46)	(44)
Lumen, parasite metazoan	4 (9%)	3 (7%)	1 (2%)	
Intestine small, duodenum	(47)	(45)	(48)	(47)
Diverticulum		1 (2%)		
Intestine small, jejunum	(47)	(42)	(46)	(44)
Parasite metazoan	1 (2%)			
Liver	(48)	(47)	(48)	(48)
Angiectasis		1 (2%)	1 (2%)	
Basophilic focus	15 (31%)	22 (47%)	25 (52%)	31 (65%)
Clear cell focus	3 (6%)	1 (2%)	2 (4%)	5 (10%)
Degeneration, cystic	15 (31%)	17 (36%)	8 (17%)	4 (8%)
Eosinophilic focus	3 (6%)	7 (15%)	5 (10%)	10 (21%)
Granuloma, multifocal		1 (2%)		
Hematopoietic cell proliferation	2 (4%)			
Hepatodiaphragmatic nodule	2 (4%)	4 (9%)	4 (8%)	3 (6%)
Inflammation, chronic	1 (2%)			
Mixed cell focus	1 (2%)	1 (2%)	1 (2%)	5 (10%)
Pigmentation, hemosiderin		1 (2%)		
Thrombosis				2 (4%)
Vacuolization cytoplasmic	11 (23%)	10 (21%)	12 (25%)	5 (10%)
Bile duct, hyperplasia	2 (4%)	2 (4%)	3 (6%)	
Hepatocyte, necrosis	7 (15%)	8 (17%)	1 (2%)	3 (6%)
Mesentery	(10)	(9)	(9)	(11)
Hemorrhage	3 (30%)		1 (11%)	4 (36%)
Fat, inflammation, granulomatous	1 (10%)	1 (11%)	3 (33%)	1 (9%)
Fat, necrosis	7 (70%)	7 (78%)	1 (11%)	7 (64%)



TABLE A5

Summary of the Incidence of Nonneoplastic Lesions in Male Rats in the 2-Year Inhalation Study of Acetonitrile  
(continued)

	0 ppm	100 ppm	200 ppm	400 ppm
<b>2-Year Study</b> (continued)				
<b>Alimentary System</b> (continued)				
Pancreas	(48)	(47)	(48)	(48)
Hemorrhage				2 (4%)
Acinus, atrophy	21 (44%)	30 (64%)	27 (56%)	29 (60%)
Artery, inflammation		1 (2%)		2 (4%)
Duct, cyst	1 (2%)	1 (2%)		
Duct, hyperplasia		1 (2%)		
Stomach, forestomach	(48)	(47)	(48)	(47)
Acanthosis	4 (8%)	4 (9%)	10 (21%)	4 (9%)
Diverticulum			2 (4%)	2 (4%)
Edema	1 (2%)	3 (6%)	1 (2%)	
Hyperkeratosis		2 (4%)		
Inflammation, suppurative	5 (10%)	4 (9%)	7 (15%)	1 (2%)
Mineralization		1 (2%)	1 (2%)	
Necrosis			1 (2%)	
Ulcer	4 (8%)	3 (6%)	7 (15%)	3 (6%)
Stomach, glandular	(48)	(46)	(48)	(47)
Hemorrhage			1 (2%)	
Inflammation, suppurative			1 (2%)	
Mineralization		1 (2%)	1 (2%)	1 (2%)
Necrosis		1 (2%)	1 (2%)	
Ulcer	1 (2%)		1 (2%)	
Tongue		(2)		(1)
Epithelium, hyperplasia		1 (50%)		
<b>Cardiovascular System</b>				
Blood vessel	(48)	(46)	(48)	(48)
Aorta, inflammation	1 (2%)	1 (2%)		
Aorta, mineralization		2 (4%)	1 (2%)	
Heart	(48)	(47)	(48)	(48)
Cardiomyopathy	9 (19%)	7 (15%)	7 (15%)	7 (15%)
Atrium, thrombosis	8 (17%)	3 (6%)	3 (6%)	1 (2%)
Myocardium, mineralization		1 (2%)	1 (2%)	
Myocardium, necrosis			1 (2%)	
<b>Endocrine System</b>				
Adrenal cortex	(48)	(47)	(48)	(48)
Hemorrhage		1 (2%)	2 (4%)	
Hyperplasia			1 (2%)	
Vacuolization cytoplasmic	7 (15%)	8 (17%)	10 (21%)	7 (15%)
Adrenal medulla	(48)	(46)	(48)	(48)
Hyperplasia	20 (42%)	16 (35%)	21 (44%)	16 (33%)
Islets, pancreatic	(48)	(47)	(48)	(48)
Hyperplasia	1 (2%)		2 (4%)	
Parathyroid gland	(47)	(46)	(46)	(45)
Hyperplasia	2 (4%)	5 (11%)	4 (9%)	2 (4%)

TABLE A5

Summary of the Incidence of Nonneoplastic Lesions in Male Rats in the 2-Year Inhalation Study of Acetonitrile  
(continued)

	0 ppm	100 ppm	200 ppm	400 ppm
<b>2-Year Study</b> (continued)				
<b>Endocrine System</b> (continued)				
Pituitary gland	(48)	(46)	(48)	(47)
Cyst	3 (6%)	7 (15%)	8 (17%)	4 (9%)
Hemorrhage	1 (2%)	2 (4%)	1 (2%)	
Pars distalis, hemorrhage	1 (2%)			
Pars distalis, hyperplasia	6 (13%)	5 (11%)	5 (10%)	8 (17%)
Pars intermedia, hyperplasia		1 (2%)		
Thyroid gland	(48)	(47)	(48)	(48)
C-cell, hyperplasia	9 (19%)	10 (21%)	7 (15%)	12 (25%)
Follicular cell, hyperplasia	1 (2%)			
<b>General Body System</b>				
None				
<b>Genital System</b>				
Epididymis	(48)	(47)	(48)	(48)
Inflammation, suppurative			1 (2%)	
Preputial gland	(47)	(47)	(47)	(48)
Ectasia	19 (40%)	14 (30%)	20 (43%)	16 (33%)
Hyperplasia	1 (2%)	2 (4%)	1 (2%)	3 (6%)
Inflammation, chronic	1 (2%)			
Inflammation, suppurative	5 (11%)	5 (11%)	5 (11%)	7 (15%)
Prostate	(48)	(47)	(48)	(48)
Cyst		1 (2%)		
Inflammation, suppurative	7 (15%)	9 (19%)	9 (19%)	12 (25%)
Epithelium, hyperplasia	1 (2%)	1 (2%)	1 (2%)	2 (4%)
Seminal vesicle	(48)	(46)	(48)	(48)
Hyperplasia		1 (2%)	1 (2%)	1 (2%)
Inflammation, suppurative	1 (2%)	1 (2%)	2 (4%)	
Testes	(48)	(47)	(48)	(48)
Hemorrhage	1 (2%)	1 (2%)		
Inflammation, suppurative	1 (2%)			
Necrosis	1 (2%)			
Germinal epithelium, atrophy	10 (21%)	13 (28%)	9 (19%)	8 (17%)
Interstitial cell, hyperplasia	16 (33%)	12 (26%)	16 (33%)	9 (19%)
<b>Hematopoietic System</b>				
Bone marrow	(48)	(47)	(48)	(48)
Hyperplasia, RE cell	7 (15%)		1 (2%)	
Myelofibrosis	2 (4%)			
Lymph node	(12)	(7)	(13)	(12)
Inflammation, granulomatous	1 (8%)			
Iliac, pigmentation				1 (8%)
Lumbar, pigmentation	1 (8%)		1 (8%)	
Pancreatic, hyperplasia, lymphoid				1 (8%)
Renal, ectasia		1 (14%)		
Renal, hemorrhage				1 (8%)
Renal, pigmentation				1 (8%)

TABLE A5

Summary of the Incidence of Nonneoplastic Lesions in Male Rats in the 2-Year Inhalation Study of Acetonitrile  
(continued)

	0 ppm	100 ppm	200 ppm	400 ppm
<b>2-Year Study</b> (continued)				
<b>Hematopoietic System</b> (continued)				
Lymph node, mandibular	(43)	(43)	(45)	(47)
Hemorrhage		1 (2%)		1 (2%)
Hyperplasia, lymphoid		2 (5%)	1 (2%)	
Lymph node, mesenteric	(48)	(47)	(47)	(48)
Hemorrhage	1 (2%)	1 (2%)		1 (2%)
Hyperplasia, lymphoid			1 (2%)	
Inflammation, granulomatous		1 (2%)		
Lymph node, mediastinal	(48)	(46)	(48)	(48)
Fibrosis			3 (6%)	
Hemorrhage	1 (2%)	5 (11%)	1 (2%)	1 (2%)
Hyperplasia, lymphoid			1 (2%)	
Pigmentation	1 (2%)	1 (2%)		
Spleen	(48)	(47)	(48)	(48)
Congestion				1 (2%)
Developmental malformation		2 (4%)	2 (4%)	2 (4%)
Fibrosis	7 (15%)	11 (23%)	18 (38%)	14 (29%)
Hemorrhage	1 (2%)			
Hyperplasia, RE cell	4 (8%)			
Necrosis		1 (2%)	2 (4%)	
Thymus	(48)	(45)	(47)	(48)
Hemorrhage			1 (2%)	
<b>Integumentary System</b>				
Mammary gland	(47)	(47)	(48)	(48)
Galactocele	1 (2%)	2 (4%)	3 (6%)	
Hemorrhage			1 (2%)	
Inflammation, chronic		1 (2%)		
Epithelium, hyperplasia		1 (2%)	3 (6%)	1 (2%)
Skin	(48)	(47)	(48)	(48)
Acanthosis	2 (4%)	2 (4%)	2 (4%)	
Cyst		1 (2%)		
Cyst epithelial inclusion		2 (4%)	1 (2%)	1 (2%)
Hyperkeratosis	1 (2%)	2 (4%)	1 (2%)	
Inflammation, chronic		1 (2%)		
Inflammation, granulomatous	2 (4%)	1 (2%)		
Inflammation, suppurative			1 (2%)	
Ulcer	4 (8%)	1 (2%)	1 (2%)	1 (2%)
Subcutaneous tissue, hemorrhage		1 (2%)	1 (2%)	
<b>Musculoskeletal System</b>				
Bone	(48)	(47)	(48)	(48)
Developmental malformation		1 (2%)		
Fibrosis		1 (2%)		

**TABLE A5**  
**Summary of the Incidence of Nonneoplastic Lesions in Male Rats in the 2-Year Inhalation Study of Acetonitrile**  
 (continued)

	0 ppm	100 ppm	200 ppm	400 ppm
<b>2-Year Study (continued)</b>				
<b>Nervous System</b>				
Brain	(48)	(47)	(48)	(48)
Demyelination		1 (2%)		
Gliosis	1 (2%)			
Hemorrhage	3 (6%)	5 (11%)	6 (13%)	4 (8%)
Hydrocephalus	7 (15%)	7 (15%)	7 (15%)	2 (4%)
Necrosis		1 (2%)		
<b>Respiratory System</b>				
Larynx	(48)	(46)	(48)	(48)
Foreign body	4 (8%)	3 (7%)	5 (10%)	6 (13%)
Hyperplasia	1 (2%)	4 (9%)	1 (2%)	4 (8%)
Inflammation, suppurative	4 (8%)	3 (7%)	4 (8%)	5 (10%)
Metaplasia, squamous	1 (2%)	2 (4%)	1 (2%)	
Mineralization		1 (2%)		
Lung	(48)	(47)	(48)	(48)
Embolus	1 (2%)			
Hemorrhage	16 (33%)	29 (62%)	26 (54%)	27 (56%)
Infarct			1 (2%)	
Infiltration cellular, histiocyte	7 (15%)	12 (26%)	13 (27%)	9 (19%)
Metaplasia, osseous		1 (2%)		
Thrombosis			1 (2%)	
Alveolar epithelium, hyperplasia	3 (6%)	3 (6%)	3 (6%)	9 (19%)
Alveolus, fibrosis	2 (4%)	1 (2%)	7 (15%)	
Alveolus, inflammation, chronic	4 (8%)			2 (4%)
Alveolus, mineralization		1 (2%)	1 (2%)	
Alveolus, pigmentation		1 (2%)	1 (2%)	
Pleura, fibrosis	1 (2%)			1 (2%)
Nose	(48)	(47)	(48)	(48)
Foreign body	10 (21%)	8 (17%)	7 (15%)	6 (13%)
Hemorrhage	6 (13%)	2 (4%)	2 (4%)	5 (10%)
Inflammation, chronic	2 (4%)	2 (4%)	3 (6%)	1 (2%)
Inflammation, suppurative	4 (8%)	4 (9%)	6 (13%)	10 (21%)
Goblet cell, respiratory epithelium, hypertrophy	9 (19%)	4 (9%)	8 (17%)	3 (6%)
Nasolacrimal duct, inflammation				1 (2%)
Nasopharyngeal duct, hyperplasia				1 (2%)
Olfactory epithelium, metaplasia		1 (2%)		
Respiratory epithelium, hyperplasia	5 (10%)	5 (11%)	6 (13%)	7 (15%)
<b>Special Senses System</b>				
Eye	(1)		(2)	(2)
Cataract				2 (100%)

TABLE A5

Summary of the Incidence of Nonneoplastic Lesions in Male Rats in the 2-Year Inhalation Study of Acetonitrile  
(continued)

	0 ppm	100 ppm	200 ppm	400 ppm
<b>2-Year Study</b> (continued)				
<b>Urinary System</b>				
Kidney	(48)	(47)	(48)	(48)
Nephropathy, chronic	45 (94%)	47 (100%)	47 (98%)	48 (100%)
Thrombosis	1 (2%)			
Cortex, necrosis	1 (2%)	1 (2%)	3 (6%)	
Pelvis, dilatation		1 (2%)		1 (2%)
Pelvis, transitional epithelium, hyperplasia	3 (6%)	3 (6%)	1 (2%)	1 (2%)
Renal tubule, hyperplasia	1 (2%)		1 (2%)	
Renal tubule, mineralization		1 (2%)	1 (2%)	
Urinary bladder	(48)	(47)	(48)	(48)
Hemorrhage	2 (4%)	1 (2%)		
Inflammation, suppurative		1 (2%)		
Metaplasia, squamous	1 (2%)			
Mineralization		1 (2%)		
Ulcer	1 (2%)			
Transitional epithelium, hyperplasia		2 (4%)		2 (4%)



**APPENDIX B**  
**SUMMARY OF LESIONS IN FEMALE RATS**  
**IN THE 2-YEAR INHALATION STUDY**  
**OF ACETONITRILE**

<b>TABLE B1</b>	<b>Summary of the Incidence of Neoplasms in Female Rats in the 2-Year Inhalation Study of Acetonitrile .....</b>	<b>109</b>
<b>TABLE B2</b>	<b>Individual Animal Tumor Pathology of Female Rats in the 2-Year Inhalation Study of Acetonitrile .....</b>	<b>114</b>
<b>TABLE B3</b>	<b>Statistical Analysis of Primary Neoplasms in Female Rats in the 2-Year Inhalation Study of Acetonitrile .....</b>	<b>132</b>
<b>TABLE B4</b>	<b>Summary of the Incidence of Nonneoplastic Lesions in Female Rats in the 2-Year Inhalation Study of Acetonitrile .....</b>	<b>136</b>





**TABLE B1**  
**Summary of the Incidence of Neoplasms in Female Rats in the 2-Year Inhalation Study of Acetonitrile<sup>a</sup>**

	0 ppm	100 ppm	200 ppm	400 ppm
<b>Disposition Summary</b>				
Animals initially in study	56	56	56	56
<b>15-Month interim evaluation</b>	8	8	8	8
Early deaths				
Accidental death	1			
Moribund	24	25	21	14
Natural deaths		2	1	5
Survivors				
Terminal sacrifice	23	21	26	29
Animals examined microscopically	56	56	56	56
<b>15-Month Interim Evaluation</b>				
<b>Endocrine System</b>				
Pituitary gland	(8)	(8)	(8)	(8)
Pars distalis, adenoma	3 (38%)		2 (25%)	4 (50%)
Thyroid gland	(8)	(8)	(8)	(8)
C-cell, adenoma			1 (13%)	1 (13%)
<b>Genital System</b>				
Clitoral gland	(8)	(8)	(8)	(8)
Carcinoma				1 (13%)
Uterus	(8)	(8)	(8)	(8)
Polyp stromal			1 (13%)	1 (13%)
Bilateral, polyp stromal		1 (13%)		
<b>Integumentary System</b>				
Mammary gland	(8)	(8)	(8)	(8)
Fibroadenoma			1 (13%)	2 (25%)
<b>Systemic Lesions</b>				
Multiple organs <sup>b</sup>	(8)	(8)	(8)	(8)
Leukemia mononuclear		1 (13%)		
<b>Systems Examined With No Neoplasms Observed</b>				
Alimentary System				
Cardiovascular System				
General Body System				
Hematopoietic System				
Musculoskeletal System				
Nervous System				
Respiratory System				
Special Senses System				
Urinary System				

**TABLE B1**  
**Summary of the Incidence of Neoplasms in Female Rats in the 2-Year Inhalation Study of Acetonitrile (continued)**

	0 ppm	100 ppm	200 ppm	400 ppm
<b>2-Year Study</b>				
<b>Alimentary System</b>				
Intestine small, jejunum	(47)	(47)	(48)	(45)
Intestine small, ileum	(47)	(47)	(46)	(45)
Liver	(48)	(48)	(48)	(46)
Fibrous histiocytoma, metastatic, skin		2 (4%)		
Hepatocellular adenoma		1 (2%)		
Mesentery	(10)	(9)	(8)	(9)
Granulosa-theca tumor malignant, metastatic, ovary		1 (11%)		
Lipoma		1 (11%)	1 (13%)	
Pancreas	(48)	(48)	(48)	(46)
Pharynx	(1)			
Squamous cell papilloma	1 (100%)			
Salivary glands	(48)	(46)	(48)	(47)
Fibrous histiocytoma, metastatic, skin		1 (2%)		
<b>Cardiovascular System</b>				
Blood vessel	(48)	(48)	(48)	(47)
Fibrous histiocytoma, metastatic, skin		1 (2%)		
Heart	(48)	(48)	(48)	(47)
<b>Endocrine System</b>				
Adrenal cortex	(48)	(48)	(48)	(46)
Granulosa-theca tumor malignant, metastatic, ovary		1 (2%)		
Adrenal medulla	(48)	(48)	(47)	(47)
Neoplasm NOS				1 (2%)
Pheochromocytoma malignant			1 (2%)	
Pheochromocytoma benign	1 (2%)	2 (4%)	2 (4%)	2 (4%)
Islets, pancreatic	(48)	(48)	(48)	(46)
Adenoma			2 (4%)	
Carcinoma		1 (2%)		1 (2%)
Parathyroid gland	(44)	(44)	(44)	(45)
Carcinoma, metastatic, thyroid gland		1 (2%)		
Pituitary gland	(48)	(48)	(47)	(45)
Schwannoma malignant, metastatic, brain			1 (2%)	
Pars distalis, adenoma	24 (50%)	26 (54%)	28 (60%)	29 (64%)
Pars intermedia, adenoma		1 (2%)		
Thyroid gland	(48)	(48)	(48)	(46)
C-cell, adenoma	3 (6%)	4 (8%)	4 (8%)	4 (9%)
C-cell, carcinoma		1 (2%)		
Follicular cell, adenoma		2 (4%)		
Follicular cell, carcinoma	1 (2%)			
<b>General Body System</b>				
None				

**TABLE B1**  
**Summary of the Incidence of Neoplasms in Female Rats in the 2-Year Inhalation Study of Acetonitrile (continued)**

	0 ppm	100 ppm	200 ppm	400 ppm
<b>2-Year Study (continued)</b>				
<b>Genital System</b>				
Clitoral gland	(46)	(42)	(47)	(45)
Adenoma	1 (2%)	1 (2%)	1 (2%)	3 (7%)
Carcinoma	4 (9%)	1 (2%)	4 (9%)	2 (4%)
Ovary	(48)	(48)	(48)	(47)
Granulosa-theca tumor malignant		2 (4%)		
Uterus	(48)	(48)	(48)	(47)
Carcinoma				1 (2%)
Hemangioma				1 (2%)
Leiomyosarcoma		1 (2%)		
Polyp stromal	7 (15%)	4 (8%)	7 (15%)	5 (11%)
Bilateral, polyp stromal			2 (4%)	
<b>Hematopoietic System</b>				
Bone marrow	(48)	(48)	(48)	(46)
Lymph node	(7)	(5)	(8)	(8)
Renal, granulosa-theca tumor malignant, metastatic, ovary		1 (20%)		
Lymph node, bronchial	(43)	(39)	(41)	(40)
Fibrous histiocytoma, metastatic, skin		1 (3%)		
Lymph node, mandibular	(46)	(46)	(45)	(42)
Fibrous histiocytoma, metastatic, skin		1 (2%)		
Lymph node, mesenteric	(46)	(47)	(47)	(47)
Lymph node, mediastinal	(48)	(46)	(45)	(46)
Fibrous histiocytoma, metastatic		1 (2%)		
Spleen	(48)	(48)	(48)	(45)
Thymus	(48)	(48)	(48)	(47)
Thymoma NOS				1 (2%)
<b>Integumentary System</b>				
Mammary gland	(48)	(48)	(48)	(47)
Carcinoma	2 (4%)	4 (8%)	3 (6%)	3 (6%)
Fibroadenoma	12 (25%)	21 (44%)	17 (35%)	16 (34%)
Fibroadenoma, multiple	4 (8%)	6 (13%)	4 (8%)	7 (15%)
Fibrosarcoma	1 (2%)			
Skin	(48)	(48)	(48)	(48)
Basal cell carcinoma	1 (2%)			
Fibroma	1 (2%)	1 (2%)		
Fibroma, multiple				1 (2%)
Fibrous histiocytoma		2 (4%)		
Squamous cell carcinoma	1 (2%)			
Trichoepithelioma	1 (2%)			
Pinna, melanoma NOS			1 (2%)	
Subcutaneous tissue, sarcoma	1 (2%)			

**TABLE B1**  
**Summary of the Incidence of Neoplasms in Female Rats in the 2-Year Inhalation Study of Acetonitrile (continued)**

	0 ppm	100 ppm	200 ppm	400 ppm
<b>2-Year Study (continued)</b>				
<b>Musculoskeletal System</b>				
Bone	(47)	(48)	(48)	(47)
Schwannoma malignant, metastatic, brain			1 (2%)	
Cranium, carcinoma, metastatic, Zymbal's gland	1 (2%)			
Skeletal muscle		(1)		
Fibrous histiocytoma, metastatic, skin		1 (100%)		
<b>Nervous System</b>				
Brain	(48)	(48)	(48)	(47)
Astrocytoma NOS	1 (2%)			
Carcinoma, metastatic, Zymbal's gland	1 (2%)			
Glioma NOS		1 (2%)	1 (2%)	
Cranial nerve, schwannoma malignant			1 (2%)	
<b>Respiratory System</b>				
Lung	(48)	(48)	(48)	(46)
Alveolar/bronchiolar adenoma				2 (4%)
Carcinoma, metastatic, mammary gland		1 (2%)		
Fibrous histiocytoma, metastatic, skin		2 (4%)		
<b>Special Senses System</b>				
Zymbal's gland	(2)	(1)		
Carcinoma	2 (100%)	1 (100%)		
<b>Urinary System</b>				
Kidney	(48)	(48)	(48)	(46)
Granulosa-theca tumor malignant, metastatic, ovary		1 (2%)		
Lipoma			1 (2%)	
Urinary bladder	(48)	(48)	(47)	(45)
Papilloma	1 (2%)			
<b>Systemic Lesions</b>				
Multiple organs	(48)	(48)	(48)	(48)
Leukemia mononuclear	18 (38%)	22 (46%)	20 (42%)	24 (50%)

**TABLE B1**  
**Summary of the Incidence of Neoplasms in Female Rats in the 2-Year Inhalation Study of Acetonitrile** (continued)

	0 ppm	100 ppm	200 ppm	400 ppm
<b>Neoplasm Summary</b>				
Total animals with primary neoplasms <sup>c</sup>				
15-Month interim evaluation	3	2	5	5
2-Year study	47	46	45	46
Total primary neoplasms				
15-Month interim evaluation	3	2	5	9
2-Year study	88	106	100	103
Total animals with benign neoplasms				
15-Month interim evaluation	3	1	5	5
2-Year study	38	39	38	38
Total benign neoplasms				
15-Month interim evaluation	3	1	5	8
2-Year study	56	70	69	70
Total animals with malignant neoplasms				
15-Month interim evaluation		1		1
2-Year study	29	28	23	27
Total malignant neoplasms				
15-Month interim evaluation		1		1
2-Year study	31	35	29	31
Total animals with metastatic neoplasms				
2-Year study	2	6	1	
Total metastatic neoplasms				
2-Year study	2	16	2	
Total animals with uncertain neoplasms- benign or malignant				
2-Year study	1	1	2	2
Total uncertain neoplasms				
2-Year study	1	1	2	2

<sup>a</sup> Number of animals examined microscopically at the site and the number of animals with neoplasm

<sup>b</sup> Number of animals with any tissue examined microscopically

<sup>c</sup> Primary neoplasms: all neoplasms except metastatic neoplasms

**TABLE B2  
Individual Animal Tumor Pathology of Female Rats in the 2-Year Inhalation Study of Acetonitrile: 0 ppm**

Number of Days on Study	1	3	3	3	3	4	4	5	5	5	5	6	6	6	6	7	7	7	7	7	7	7	7	7	7	7	7	7		
	0	1	3	6	7	2	7	2	3	8	9	2	2	3	6	6	0	0	0	1	2	2	2	2	2	2	2	2		
	5	0	1	0	7	7	0	5	0	8	7	3	5	7	2	5	2	6	7	4	1	1	1	7	9					
Carcass ID Number	0	0	0	0	0	0	1	0	1	1	0	0	1	1	0	0	0	0	0	1	0	0	0	1	0	0	0	1	0	0
	7	8	8	9	7	5	0	6	0	0	7	7	0	1	9	7	9	5	1	9	6	6	0	8	7					
	5	7	9	3	3	8	6	8	1	5	7	2	2	2	9	9	6	7	1	5	4	9	4	4	8					
<b>Alimentary System</b>																														
Esophagus	+	+	+	+	+	+	+	+	+	+	+	+	+	+	+	+	+	+	+	+	+	+	+	+	+	+	+	+	+	+
Intestine large, colon	+	+	A	+	+	+	+	+	+	+	+	+	+	+	+	+	+	+	+	+	+	+	+	+	+	+	+	+	+	+
Intestine large, rectum	+	+	A	+	+	+	+	+	+	+	+	+	+	+	+	+	+	+	+	+	+	+	+	+	+	+	+	+	+	+
Intestine large, cecum	+	+	A	+	+	+	+	+	+	+	+	+	+	+	+	+	+	+	+	+	+	+	+	+	+	+	+	+	+	+
Intestine small, duodenum	+	+	A	+	+	+	+	+	+	+	+	+	+	+	+	+	+	+	M	+	+	+	+	+	+	+	+	+	+	+
Intestine small, jejunum	+	+	A	+	+	+	+	+	+	+	+	+	+	+	+	+	+	+	+	+	+	+	+	+	+	+	+	+	+	+
Intestine small, ileum	+	+	A	+	+	+	+	+	+	+	+	+	+	+	+	+	+	+	+	+	+	+	+	+	+	+	+	+	+	+
Liver	+	+	+	+	+	+	+	+	+	+	+	+	+	+	+	+	+	+	+	+	+	+	+	+	+	+	+	+	+	+
Mesentery					+	+	+								+															+
Pancreas	+	+	+	+	+	+	+	+	+	+	+	+	+	+	+	+	+	+	+	+	+	+	+	+	+	+	+	+	+	+
Pharynx																														
Squamous cell papilloma																														
Salivary glands	+	+	+	+	+	+	+	+	+	+	+	+	+	+	+	+	+	+	+	+	+	+	+	+	+	+	+	+	+	+
Stomach, forestomach	+	+	+	+	+	+	+	+	+	+	+	+	+	+	+	+	+	+	+	+	+	+	+	+	+	+	+	+	+	+
Stomach, glandular	+	+	+	+	+	+	+	+	+	+	+	+	+	+	+	+	+	+	+	+	+	I	+	+	+	+	+	+	+	+
<b>Cardiovascular System</b>																														
Blood vessel	+	+	+	+	+	+	+	+	+	+	+	+	+	+	+	+	+	+	+	+	+	+	+	+	+	+	+	+	+	+
Heart	+	+	+	+	+	+	+	+	+	+	+	+	+	+	+	+	+	+	+	+	+	+	+	+	+	+	+	+	+	+
<b>Endocrine System</b>																														
Adrenal cortex	+	+	+	+	+	+	+	+	+	+	+	+	+	+	+	+	+	+	+	+	+	+	+	+	+	+	+	+	+	+
Adrenal medulla	+	+	+	+	+	+	+	+	+	+	+	+	+	+	+	+	+	+	+	+	+	+	+	+	+	+	+	+	+	+
Pheochromocytoma benign																														
Islets, pancreatic	+	+	+	+	+	+	+	+	+	+	+	+	+	+	+	+	+	+	+	+	+	+	+	+	+	+	+	+	+	+
Parathyroid gland	+	+	+	+	M	+	+	+	+	+	+	+	+	+	+	+	+	+	M	M	+	+	+	+	+	+	+	+	+	+
Pituitary gland	+	+	+	+	+	+	+	+	+	+	+	+	+	+	+	+	+	+	+	+	+	+	+	+	+	+	+	+	+	+
Pars distalis, adenoma									X	X	X	X						X	X	X	X								X	X
Thyroid gland	+	+	+	+	+	+	+	+	+	+	+	+	+	+	+	+	+	+	+	+	+	+	+	+	+	+	+	+	+	+
C-cell, adenoma																		X		X										
Follicular cell, carcinoma							X																							
<b>General Body System</b>																														
None																														
<b>Genital System</b>																														
Clitoral gland	+	+	+	+	+	+	+	+	+			+	+	+	+	+	+	+	+	+	+	+	+	+	+	+	+	+	+	+
Adenoma																														
Carcinoma													X														X			
Ovary	+	+	+	+	+	+	+	+	+	+	+	+	+	+	+	+	+	+	+	+	+	+	+	+	+	+	+	+	+	+
Uterus	+	+	+	+	+	+	+	+	+	+	+	+	+	+	+	+	+	+	+	+	+	+	+	+	+	+	+	+	+	+
Polyp stromal				X																										

+: Tissue examined microscopically  
A: Autolysis precludes examination

M: Missing tissue  
I: Insufficient tissue

X: Lesion present  
Blank: Not examined







**TABLE B2**  
**Individual Animal Tumor Pathology of Female Rats in the 2-Year Inhalation Study of Acetonitrile: 0 ppm (continued)**

Number of Days on Study	7 7 7 7 7 7 7 7 7 7 7 7 7 7 7 7 7 7 7 7																				Total Tissues/ Tumors		
	3 3 3 3 3 3 3 3 3 3 3 3 3 3 3 3 3 3 3 3																						
Carcass ID Number	4 4 4 4 4 4 4 4 4 4 4 4 4 4 4 4 4 4 4 4																						
	0 0 0 0 0 0 0 0 0 0 0 0 0 0 0 0 1 1 1 1																						
<b>Hematopoietic System</b>																							
Blood																				+	1		
Bone marrow	+	+	+	+	+	+	+	+	+	+	+	+	+	+	+	+	+	+	+	+	48		
Lymph node																					7		
Lymph node, bronchial	+	+	+	+	+	+	+	+	+	+	+	+	+	+	+	+	M	+	+	M	43		
Lymph node, mandibular	+	+	+	+	+	+	+	+	+	+	+	+	+	+	+	+	+	+	+	+	46		
Lymph node, mesenteric	+	+	M	+	+	+	+	+	+	+	+	+	+	+	+	+	+	+	+	+	46		
Lymph node, mediastinal	+	+	+	+	+	+	+	+	+	+	+	+	+	+	+	+	+	+	+	+	48		
Spleen	+	+	+	+	+	+	+	+	+	+	+	+	+	+	+	+	+	+	+	+	48		
Thymus	+	+	+	+	+	+	+	+	+	+	+	+	+	+	+	+	+	+	+	+	48		
<b>Integumentary System</b>																							
Mammary gland	+	+	+	+	+	+	+	+	+	+	+	+	+	+	+	+	+	+	+	+	48		
Carcinoma																	X	X	2				
Fibroadenoma					X	X						X	X	X	X	X	12						
Fibroadenoma, multiple					X	X	X												4				
Fibrosarcoma																					1		
Skin	+	+	+	+	+	+	+	+	+	+	+	+	+	+	+	+	+	+	+	+	48		
Basal cell carcinoma										X											1		
Fibroma																					1		
Squamous cell carcinoma					X												1						
Trichoepithelioma										X											1		
Subcutaneous tissue, sarcoma																					1		
<b>Musculoskeletal System</b>																							
Bone	+	+	+	+	+	+	+	+	+	+	+	+	+	+	+	+	I	+	+	+	47		
Cranium, carcinoma, metastatic, Zymbal's gland																					1		
<b>Nervous System</b>																							
Brain	+	+	+	+	+	+	+	+	+	+	+	+	+	+	+	+	+	+	+	+	48		
Astrocytoma NOS																					1		
Carcinoma, metastatic, Zymbal's gland																					1		
Spinal cord																					1		
<b>Respiratory System</b>																							
Larynx	+	+	+	+	+	+	+	+	+	+	+	+	+	+	+	+	+	+	+	+	47		
Lung	+	+	+	+	+	+	+	+	+	+	+	+	+	+	+	+	+	+	+	+	48		
Nose	+	+	+	+	+	+	+	+	+	+	+	+	+	+	+	+	+	+	+	+	47		
Trachea	+	+	+	+	+	+	+	+	+	+	+	+	+	+	+	+	+	+	+	+	48		
<b>Special Senses System</b>																							
Eye																		+	3				
Zymbal's gland																					2		
Carcinoma																					2		
<b>Urinary System</b>																							
Kidney	+	+	+	+	+	+	+	+	+	+	+	+	+	+	+	+	+	+	+	+	48		
Urinary bladder	+	+	+	+	+	+	+	+	+	+	+	+	+	+	+	+	+	+	+	+	48		
Papilloma																					1		
<b>Systemic Lesions</b>																							
Multiple organs	+	+	+	+	+	+	+	+	+	+	+	+	+	+	+	+	+	+	+	+	48		
Leukemia mononuclear	X					X								X	X							X	18











**TABLE B2**  
**Individual Animal Tumor Pathology of Female Rats in the 2-Year Inhalation Study of Acetonitrile: 100 ppm (continued)**

Number of Days on Study	7	7	7	7	7	7	7	7	7	7	7	7	7	7	7	7	7	7	7	7	7	7	7	Total Tissues/ Tumors
	1	2	3	3	3	3	3	3	3	3	3	3	3	3	3	3	3	3	3	3	3	3	3	
	9	1	5	5	5	5	5	5	5	5	5	5	5	5	5	5	5	5	5	5	5	5	5	
<b>Carcass ID Number</b>	1	2	1	1	1	1	1	1	1	1	1	1	1	1	2	2	2	2	2	2	2	2	2	
	7	1	7	7	7	8	8	8	8	9	9	9	9	9	0	0	0	0	1	1	1	1	2	
	7	2	0	3	5	0	4	5	9	2	6	7	8	9	1	2	4	8	0	1	7	8	2	
<b>Respiratory System</b>																								
Larynx	+	+	+	+	+	+	+	+	+	+	+	+	+	+	+	+	+	+	+	+	+	+	48	
Lung	+	+	+	+	+	+	+	+	+	+	+	+	+	+	+	+	+	+	+	+	+	+	48	
Carcinoma, metastatic, mammary gland																							1	
Fibrous histiocytoma, metastatic, skin																							2	
Nose	+	+	+	+	+	+	+	+	+	+	+	+	+	+	+	+	+	+	+	+	+	+	47	
Trachea	+	+	+	+	+	+	+	+	+	+	+	+	+	+	+	+	+	+	+	+	+	+	48	
<b>Special Senses System</b>																								
Eye																							1	
Harderian gland																							1	
Zymbal's gland																							1	
Carcinoma																							1	
<b>Urinary System</b>																								
Kidney	+	+	+	+	+	+	+	+	+	+	+	+	+	+	+	+	+	+	+	+	+	+	48	
Granulosa-theca tumor malignant, metastatic, ovary																							1	
Urinary bladder	+	+	+	+	+	+	+	+	+	+	+	+	+	+	+	+	+	+	+	+	+	+	48	
<b>Systemic Lesions</b>																								
Multiple organs	+	+	+	+	+	+	+	+	+	+	+	+	+	+	+	+	+	+	+	+	+	+	48	
Leukemia mononuclear	X	X	X	X							X	X	X	X							X	X	22	





**TABLE B2  
Individual Animal Tumor Pathology of Female Rats in the 2-Year Inhalation Study of Acetonitrile: 200 ppm (continued)**

Number of Days on Study	7	7	7	7	7	7	7	7	7	7	7	7	7	7	7	7	7	7	7	7	7		
	3	3	3	3	3	3	3	3	3	3	3	3	3	3	3	3	3	3	3	3	3		
	5	5	5	5	5	5	5	5	5	5	5	5	5	5	5	5	5	5	5	5	5		
Carcass ID Number	2	2	2	2	2	3	3	3	3	3	3	3	3	3	3	3	3	3	3	3	3		
	8	8	9	9	9	0	0	0	0	0	1	1	1	1	2	2	2	2	2	2	3	3	
	7	9	2	6	8	1	2	3	4	8	0	4	7	9	0	2	3	4	5	9	1	2	
	Total Tissues/ Tumors																						
<b>Alimentary System</b>																							
Esophagus	+	+	+	+	+	+	+	+	+	+	+	+	+	+	+	+	+	+	+	+	+	+	48
Intestine large, colon	+	+	+	+	+	+	+	+	+	+	+	+	+	+	+	+	+	+	+	+	+	+	48
Intestine large, rectum	+	+	+	+	+	+	+	+	+	+	+	+	+	+	+	+	+	+	+	+	+	+	48
Intestine large, cecum	+	+	+	+	+	+	+	+	+	+	+	+	+	+	+	+	+	+	+	+	+	+	47
Intestine small, duodenum	+	+	+	+	+	+	+	+	+	+	+	+	+	+	+	+	+	+	+	+	+	+	48
Intestine small, jejunum	+	+	+	+	+	+	+	+	+	+	+	+	+	+	+	+	+	+	+	+	+	+	48
Intestine small, ileum	+	+	+	+	+	+	+	+	+	+	+	+	+	+	+	+	+	+	+	+	+	+	46
Liver	+	+	+	+	+	+	+	+	+	+	+	+	+	+	+	+	+	+	+	+	+	+	48
Mesentery			+																	+		+	8
Lipoma																					X		1
Pancreas	+	+	+	+	+	+	+	+	+	+	+	+	+	+	+	+	+	+	+	+	+	+	48
Salivary glands	+	+	+	+	+	+	+	+	+	+	+	+	+	+	+	+	+	+	+	+	+	+	48
Stomach, forestomach	+	+	+	+	+	+	+	+	+	+	+	+	+	+	+	+	+	+	+	+	+	+	47
Stomach, glandular	+	+	+	+	+	+	+	+	+	+	+	+	+	+	+	+	+	+	+	+	+	+	48
<b>Cardiovascular System</b>																							
Blood vessel	+	+	+	+	+	+	+	+	+	+	+	+	+	+	+	+	+	+	+	+	+	+	48
Heart	+	+	+	+	+	+	+	+	+	+	+	+	+	+	+	+	+	+	+	+	+	+	48
<b>Endocrine System</b>																							
Adrenal cortex	+	+	+	+	+	+	+	+	+	+	+	+	+	+	+	+	+	+	+	+	+	+	48
Adrenal medulla	+	+	+	+	+	+	+	+	+	+	+	+	+	+	+	+	+	+	+	+	+	+	47
Pheochromocytoma malignant																							1
Pheochromocytoma benign																X							2
Islets, pancreatic	+	+	+	+	+	+	+	+	+	+	+	+	+	+	+	+	+	+	+	+	+	+	48
Adenoma									X		X												2
Parathyroid gland	+	+	+	+	+	+	+	+	+	+	+	+	+	+	+	+	+	+	M	+	+	+	44
Pituitary gland	+	+	+	+	+	+	+	+	+	+	+	+	+	+	+	+	+	+	+	+	+	+	47
Schwannoma malignant, metastatic, brain																							1
Pars distalis, adenoma	X	X	X	X	X	X					X	X	X	X	X	X				X	X	X	28
Thyroid gland	+	+	+	+	+	+	+	+	+	+	+	+	+	+	+	+	+	+	+	+	+	+	48
C-cell, adenoma							X	X	X											X			4
<b>General Body System</b>																							
None																							
<b>Genital System</b>																							
Clitoral gland	+	+	+	+	+	+	+	+	+	+	+	+	+	+	+	+	+	+	+	+	+	+	47
Adenoma	X																						1
Carcinoma		X			X							X							X				4
Ovary	+	+	+	+	+	+	+	+	+	+	+	+	+	+	+	+	+	+	+	+	+	+	48
Uterus	+	+	+	+	+	+	+	+	+	+	+	+	+	+	+	+	+	+	+	+	+	+	48
Polyp stromal							X							X		X	X	X					7
Bilateral, polyp stromal						X													X				2

**TABLE B2**  
**Individual Animal Tumor Pathology of Female Rats in the 2-Year Inhalation Study of Acetonitrile: 200 ppm (continued)**

	2	3	4	4	5	5	5	5	5	5	5	6	6	6	6	6	6	6	6	7	7	7	7	7	
Number of Days on Study	9	7	6	8	3	5	6	6	6	8	9	2	2	5	5	6	7	7	8	9	1	2	3	3	
	2	6	9	5	4	5	6	6	7	8	7	3	5	1	1	5	1	1	5	3	9	7	5	5	
Carcass ID Number	3	3	2	3	3	2	2	3	3	3	2	2	2	2	3	3	2	3	3	3	3	2	2	2	
	1	0	8	1	0	9	9	2	0	3	8	8	9	9	2	3	9	1	2	1	3	8	8	8	
	8	7	5	5	9	4	3	6	5	5	8	4	0	5	7	4	9	6	8	3	0	3	1	2	6
<b>Hematopoietic System</b>																									
Bone marrow	+	+	+	+	+	+	+	+	+	+	+	+	+	+	+	+	+	+	+	+	+	+	+	+	
Lymph node									+					+	+						+				
Lymph node, bronchial	+	+	+	M	+	+	+	+	M	+	+	M	+	+	+	+	+	M	+	M	+	+	+	+	
Lymph node, mandibular	+	+	+	+	+	+	+	+	+	+	+	+	+	+	+	+	+	M	+	+	+	+	M	+	
Lymph node, mesenteric	+	+	+	+	+	+	+	+	+	+	+	+	+	+	+	+	+	M	+	+	+	+	+	+	
Lymph node, mediastinal	+	+	+	+	+	+	+	+	+	+	+	+	+	+	+	+	+	+	+	+	M	+	M	+	
Spleen	+	+	+	+	+	+	+	+	+	+	+	+	+	+	+	+	+	+	+	+	+	+	+	+	
Thymus	+	+	+	+	+	+	+	+	+	+	+	+	+	+	+	+	+	+	+	+	+	+	+	+	
<b>Integumentary System</b>																									
Mammary gland	+	+	+	+	+	+	+	+	+	+	+	+	+	+	+	+	+	+	+	+	+	+	+	+	
Carcinoma																								X	
Fibroadenoma				X				X	X				X	X		X		X	X						
Fibroadenoma, multiple																									
Skin	+	+	+	+	+	+	+	+	+	+	+	+	+	+	+	+	+	+	+	+	+	+	+	+	
Pinna, melanoma NOS																									
<b>Musculoskeletal System</b>																									
Bone	+	+	+	+	+	+	+	+	+	+	+	+	+	+	+	+	+	+	+	+	+	+	+	+	
Schwannoma malignant, metastatic, brain	X																								
<b>Nervous System</b>																									
Brain	+	+	+	+	+	+	+	+	+	+	+	+	+	+	+	+	+	+	+	+	+	+	+	+	
Glioma NOS									X																
Cranial nerve, schwannoma malignant	X																								
<b>Respiratory System</b>																									
Larynx	+	+	+	+	+	+	+	+	+	+	+	+	+	+	+	+	+	+	+	+	+	+	+	+	
Lung	+	+	+	+	+	+	+	+	+	+	+	+	+	+	+	+	+	+	+	+	+	+	+	+	
Nose	+	+	+	+	+	+	+	+	+	+	+	+	+	+	+	+	+	+	+	+	+	+	+	+	
Trachea	+	+	+	+	+	+	+	+	+	+	+	+	+	+	+	+	+	+	+	+	+	+	+	+	
<b>Special Senses System</b>																									
Ear																									
Eye																								+	
Lacrimal gland																									
<b>Urinary System</b>																									
Kidney	+	+	+	+	+	+	+	+	+	+	+	+	+	+	+	+	+	+	+	+	+	+	+	+	
Lipoma																									
Urinary bladder	+	+	+	+	+	+	+	+	+	+	+	+	+	+	+	+	+	+	+	+	I	+	+	+	
<b>Systemic Lesions</b>																									
Multiple organs	+	+	+	+	+	+	+	+	+	+	+	+	+	+	+	+	+	+	+	+	+	+	+	+	
Leukemia mononuclear					X					X	X	X			X	X	X			X	X	X			

TABLE B2 Individual Animal Tumor Pathology of Female Rats in the 2-Year Inhalation Study of Acetonitrile: 200 ppm (continued)

Table with columns for Number of Days on Study, Carcass ID Number, and various organ systems (Hematopoietic, Integumentary, Musculoskeletal, Nervous, Respiratory, Special Senses, Urinary, Systemic Lesions) with counts for each. Includes a 'Total Tissues/Tumors' column on the right.



**TABLE B2**  
**Individual Animal Tumor Pathology of Female Rats in the 2-Year Inhalation Study of Acetonitrile: 400 ppm (continued)**

Number of Days on Study	7	7	7	7	7	7	7	7	7	7	7	7	7	7	7	7	7	7	7	7	7	7	7	Total
Carcass ID Number	3	3	3	3	3	3	3	3	3	3	3	3	3	3	3	3	3	3	3	3	3	3	3	Tissues/ Tumors
	4	4	4	4	4	4	4	4	4	4	4	4	4	4	4	4	4	4	4	4	4	4	4	
<b>Alimentary System</b>																								
Esophagus	+	+	+	+	+	+	+	+	+	+	+	+	+	+	+	+	+	+	+	+	+	+	+	47
Intestine large, colon	+	+	+	+	+	+	+	+	+	+	+	+	+	+	+	+	+	+	+	+	+	+	+	45
Intestine large, rectum	+	+	+	+	+	+	+	+	+	+	+	+	+	+	+	I	+	+	+	+	+	+	+	45
Intestine large, cecum	+	+	+	+	+	+	+	+	+	+	+	+	+	+	+	+	+	+	+	+	+	+	+	45
Intestine small, duodenum	+	+	+	+	+	+	+	+	+	+	+	+	+	+	+	+	+	+	+	+	+	+	+	46
Intestine small, jejunum	+	+	+	+	+	+	+	+	+	+	+	+	+	+	+	+	+	+	+	+	+	+	+	45
Intestine small, ileum	+	+	+	+	+	+	+	+	+	+	+	+	+	+	+	+	+	+	+	+	+	+	+	45
Liver	+	+	+	+	+	+	+	+	+	+	+	+	+	+	+	+	+	+	+	+	+	+	+	46
Mesentery	+										+											+	+	9
Pancreas	+	+	+	+	+	+	+	+	+	+	+	+	+	+	+	+	+	+	+	+	+	+	+	46
Salivary glands	+	+	+	+	+	+	+	+	+	+	+	+	+	+	+	+	+	+	+	+	+	+	+	47
Stomach, forestomach	+	+	+	+	+	+	+	+	+	+	+	+	+	+	+	+	+	+	+	+	+	+	+	46
Stomach, glandular	+	+	+	+	+	+	+	+	+	+	+	+	+	+	+	+	+	+	+	+	+	+	+	46
<b>Cardiovascular System</b>																								
Blood vessel	+	+	+	+	+	+	+	+	+	+	+	+	+	+	+	+	+	+	+	+	+	+	+	47
Heart	+	+	+	+	+	+	+	+	+	+	+	+	+	+	+	+	+	+	+	+	+	+	+	47
<b>Endocrine System</b>																								
Adrenal cortex	+	+	+	+	+	+	+	+	+	+	+	+	+	+	+	+	+	+	+	+	+	+	+	46
Adrenal medulla	+	+	+	+	+	+	+	+	+	+	+	+	+	+	+	+	+	+	+	+	+	+	+	47
Neoplasm NOS																								1
Pheochromocytoma benign																								2
Islets, pancreatic	+	+	+	+	+	+	+	+	+	+	+	+	+	+	+	+	+	+	+	+	+	+	+	46
Carcinoma																								1
Parathyroid gland	+	+	+	+	+	+	+	+	+	+	+	+	+	M	+	+	+	+	+	+	+	+	+	45
Pituitary gland	+	+	+	+	+	+	+	+	+	+	+	+	+	+	+	+	+	+	+	+	+	+	+	45
Pars distalis, adenoma			X	X	X	X	X	X	X	X	X	X	X	X	X	X	X	X	X	X	X	X	X	29
Thyroid gland	+	+	+	+	+	+	+	+	+	+	+	+	+	+	+	+	+	+	+	+	+	+	+	46
C-cell, adenoma											X													4
<b>General Body System</b>																								
None																								
<b>Genital System</b>																								
Clitoral gland	+	+	+	+	+	+	+	+	+	+	+	+	+	+	+	+	+	+	+	+	+	M	+	45
Adenoma						X																		3
Carcinoma																X						X		2
Ovary	+	+	+	+	+	+	+	+	+	+	+	+	+	+	+	+	+	+	+	+	+	+	+	47
Uterus	+	+	+	+	+	+	+	+	+	+	+	+	+	+	+	+	+	+	+	+	+	+	+	47
Carcinoma																								1
Hemangioma								X																1
Polyp stromal	X						X				X											X		5

**TABLE B2**  
**Individual Animal Tumor Pathology of Female Rats in the 2-Year Inhalation Study of Acetonitrile: 400 ppm (continued)**

Number of Days on Study	3	4	5	5	6	6	6	6	6	6	6	6	6	6	7	7	7	7	7	7	7	7	7	7	7	7	7	7
Carcass ID Number	3	4	5	5	6	6	6	6	6	6	6	6	6	6	7	7	7	7	7	7	7	7	7	7	7	7	7	7
	9	2	5	7	9	1	2	6	7	7	7	7	7	7	9	0	2	2	2	2	3	3	3	3	3	3	3	3
	4	7	8	2	9	8	9	6	0	2	2	9	9	9	3	7	1	3	9	4	4	4	4	4	4	4	4	4
<b>Hematopoietic System</b>																												
Bone marrow	+	+	+	A	+	+	A	+	+	+	+	+	+	+	+	+	+	+	+	+	+	+	+	+	+	+	+	+
Lymph node					+		+									+				+	+							
Lymph node, bronchial	+	+	M	M	+	+	A	+	M	+	+	+	M	+	+	+	+	+	+	+	+	+	M	+	+	+	+	+
Lymph node, mandibular	+	+	+	+	+	+	A	+	+	M	+	+	+	+	+	+	+	+	+	+	+	+	+	+	+	+	+	+
Lymph node, mesenteric	+	+	+	+	+	+	A	+	+	+	+	+	+	+	+	+	+	+	+	+	+	+	+	+	+	+	+	+
Lymph node, mediastinal	+	+	+	+	+	+	A	+	+	+	+	+	+	+	+	+	+	+	+	+	+	+	+	+	+	+	+	+
Spleen	+	+	+	A	+	+	A	+	+	+	+	+	+	+	+	+	+	+	+	+	+	+	+	+	+	+	+	+
Thymus	+	+	+	+	+	+	A	+	+	+	+	+	+	+	+	+	+	+	+	+	+	+	+	+	+	+	+	+
Thymoma NOS												X																
<b>Integumentary System</b>																												
Mammary gland	+	+	+	+	+	+	A	+	+	+	+	+	+	+	+	+	+	+	+	+	+	+	+	+	+	+	+	+
Carcinoma												X					X										X	
Fibroadenoma	X									X	X				X	X		X										X
Fibroadenoma, multiple				X							X											X	X					
Skin	+	+	+	+	+	+	+	+	+	+	+	+	+	+	+	+	+	+	+	+	+	+	+	+	+	+	+	+
Fibroma, multiple																												
<b>Musculoskeletal System</b>																												
Bone	+	+	+	+	+	+	A	+	+	+	+	+	+	+	+	+	+	+	+	+	+	+	+	+	+	+	+	+
<b>Nervous System</b>																												
Brain	+	+	+	+	+	+	A	+	+	+	+	+	+	+	+	+	+	+	+	+	+	+	+	+	+	+	+	+
<b>Respiratory System</b>																												
Larynx	+	+	+	A	+	+	A	+	+	+	+	+	+	+	+	+	+	+	+	+	+	+	+	+	+	+	+	+
Lung	+	+	+	A	+	+	A	+	+	+	+	+	+	+	+	+	+	+	+	+	+	+	+	+	+	+	+	+
Alveolar/bronchiolar adenoma																											X	
Nose	+	+	+	A	+	+	A	+	+	+	+	+	+	+	+	+	+	+	+	+	+	+	+	+	+	+	+	+
Trachea	+	+	+	A	+	+	A	+	+	+	+	+	+	+	+	+	+	+	+	+	+	+	+	+	+	+	+	+
<b>Special Senses System</b>																												
Eye												+																
Harderian gland																									+			
<b>Urinary System</b>																												
Kidney	+	+	+	A	+	+	A	+	+	+	+	+	+	+	+	+	+	+	+	+	+	+	+	+	+	+	+	+
Urinary bladder	+	+	+	A	+	+	A	+	+	+	+	+	+	+	+	+	+	+	+	+	+	+	+	+	+	+	+	I
<b>Systemic Lesions</b>																												
Multiple organs	+	+	+	+	+	+	+	+	+	+	+	+	+	+	+	+	+	+	+	+	+	+	+	+	+	+	+	+
Leukemia mononuclear		X	X			X	X			X	X	X	X		X	X	X	X					X	X			X	

**TABLE B2**  
**Individual Animal Tumor Pathology of Female Rats in the 2-Year Inhalation Study of Acetonitrile: 400 ppm (continued)**

Number of Days on Study	7	7	7	7	7	7	7	7	7	7	7	7	7	7	7	7	7	7	7	7	7	7	7	7	7	7	Total Tissues/ Tumors
Carcass ID Number	1	1	1	1	1	1	1	2	2	2	2	3	3	3	3	4	4	4	4	4	4	4	4	4	4	4	
	1	2	3	4	5	8	9	2	3	4	7	1	4	6	7	0	2	3	4	5	6	7	8				
<b>Hematopoietic System</b>																											
Bone marrow	+	+	+	+	+	+	+	+	+	+	+	+	+	+	+	+	+	+	+	+	+	+	+	+	+	+	46
Lymph node							+							+													8
Lymph node, bronchial	+	+	+	M	+	+	+	+	+	M	+	+	+	+	+	+	+	+	+	+	+	+	+	+	+	+	40
Lymph node, mandibular	+	+	+	+	+	M	+	+	+	+	+	+	+	M	+	+	+	+	+	+	+	M	M				42
Lymph node, mesenteric	+	+	+	+	+	+	+	+	+	+	+	+	+	+	+	+	+	+	+	+	+	+	+	+	+	+	47
Lymph node, mediastinal	+	+	+	+	+	+	+	+	+	+	+	+	+	+	+	+	+	+	+	+	+	+	M	+	+	+	46
Spleen	+		+	+	+	+	+	+	+	+	+	+	+	+	+	+	+	+	+	+	+	+	+	+	+	+	45
Thymus	+	+	+	+	+	+	+	+	+	+	+	+	+	+	+	+	+	+	+	+	+	+	+	+	+	+	47
Thymoma NOS																											1
<b>Integumentary System</b>																											
Mammary gland	+	+	+	+	+	+	+	+	+	+	+	+	+	+	+	+	+	+	+	+	+	+	+	+	+	+	47
Carcinoma																											3
Fibroadenoma				X	X			X	X	X	X		X	X													16
Fibroadenoma, multiple	X						X				X																7
Skin	+	+	+	+	+	+	+	+	+	+	+	+	+	+	+	+	+	+	+	+	+	+	+	+	+	+	48
Fibroma, multiple							X																				1
<b>Musculoskeletal System</b>																											
Bone	+	+	+	+	+	+	+	+	+	+	+	+	+	+	+	+	+	+	+	+	+	+	+	+	+	+	47
<b>Nervous System</b>																											
Brain	+	+	+	+	+	+	+	+	+	+	+	+	+	+	+	+	+	+	+	+	+	+	+	+	+	+	47
<b>Respiratory System</b>																											
Larynx	+	+	+	+	+	+	+	+	+	+	+	+	+	+	+	+	+	+	+	+	+	+	+	+	+	+	46
Lung	+	+	+	+	+	+	+	+	+	+	+	+	+	+	+	+	+	+	+	+	+	+	+	+	+	+	46
Alveolar/bronchiolar adenoma												X															2
Nose	+	+	+	+	+	+	+	+	+	+	+	+	+	+	+	+	+	+	+	+	+	+	+	+	+	+	46
Trachea	+	+	+	+	+	+	+	+	+	+	+	+	+	+	+	M	+	+	+	+	+	+	+	+	+	+	45
<b>Special Senses System</b>																											
Eye																+											3
Harderian gland																											1
<b>Urinary System</b>																											
Kidney	+	+	+	+	+	+	+	+	+	+	+	+	+	+	+	+	+	+	+	+	+	+	+	+	+	+	46
Urinary bladder	+	+	+	+	+	+	+	+	+	+	+	+	+	+	+	+	+	+	+	+	+	+	+	+	+	+	45
<b>Systemic Lesions</b>																											
Multiple organs	+	+	+	+	+	+	+	+	+	+	+	+	+	+	+	+	+	+	+	+	+	+	+	+	+	+	48
Leukemia mononuclear							X					X	X	X	X		X	X	X	X							24

**TABLE B3**  
**Statistical Analysis of Primary Neoplasms in Female Rats in the 2-Year Inhalation Study of Acetonitrile**

	0 ppm	100 ppm	200 ppm	400 ppm
<b>Adrenal Medulla: Benign or Malignant Pheochromocytoma</b>				
Overall rate <sup>a</sup>	1/48 (2%)	2/48 (4%)	3/47 (6%)	2/47 (4%)
Adjusted rate <sup>b</sup>	4.3%	8.9%	8.0%	5.9%
Terminal rate <sup>c</sup>	1/23 (4%)	1/21 (5%)	1/26 (4%)	1/29 (3%)
First incidence (days)	734 (T)	719	376	672
Life table test <sup>d</sup>	P=0.498	P=0.456	P=0.346	P=0.576
Logistic regression test <sup>d</sup>	P=0.356	P=0.470	P=0.230	P=0.538
Cochran-Armitage test <sup>d</sup>	P=0.394			
Fisher exact test <sup>d</sup>		P=0.500	P=0.301	P=0.492
<b>Clitoral Gland: Adenoma</b>				
Overall rate	1/46 (2%)	1/42 (2%)	1/47 (2%)	3/45 (7%)
Adjusted rate	4.5%	2.3%	3.8%	10.7%
Terminal rate	1/22 (5%)	0/21 (0%)	1/26 (4%)	3/28 (11%)
First incidence (days)	734 (T)	600	734 (T)	734 (T)
Life table test	P=0.231	P=0.749N	P=0.725N	P=0.393
Logistic regression test	P=0.196	P=0.745	P=0.725N	P=0.393
Cochran-Armitage test	P=0.166			
Fisher exact test		P=0.730	P=0.747N	P=0.300
<b>Clitoral Gland: Carcinoma</b>				
Overall rate	4/46 (9%)	1/42 (2%)	4/47 (9%)	2/45 (4%)
Adjusted rate	14.7%	2.3%	15.4%	7.1%
Terminal rate	2/22 (9%)	0/21 (0%)	4/26 (15%)	2/28 (7%)
First incidence (days)	623	588	734 (T)	734 (T)
Life table test	P=0.286N	P=0.192N	P=0.576N	P=0.250N
Logistic regression test	P=0.340N	P=0.196N	P=0.632N	P=0.288N
Cochran-Armitage test	P=0.392N			
Fisher exact test		P=0.210N	P=0.631N	P=0.349N
<b>Clitoral Gland: Adenoma or Carcinoma</b>				
Overall rate	5/46 (11%)	2/42 (5%)	5/47 (11%)	5/45 (11%)
Adjusted rate	19.0%	4.5%	19.2%	17.9%
Terminal rate	3/22 (14%)	0/21 (0%)	5/26 (19%)	5/28 (18%)
First incidence (days)	623	588	734 (T)	734 (T)
Life table test	P=0.561N	P=0.224N	P=0.547N	P=0.488N
Logistic regression test	P=0.492	P=0.242N	P=0.621N	P=0.553N
Cochran-Armitage test	P=0.421			
Fisher exact test		P=0.256N	P=0.616N	P=0.616
<b>Mammary Gland: Fibroadenoma</b>				
Overall rate	16/48 (33%)	27/48 (56%)	21/48 (44%)	23/48 (48%)
Adjusted rate	55.9%	72.7%	60.0%	61.2%
Terminal rate	11/23 (48%)	12/21 (57%)	13/26 (50%)	15/29 (52%)
First incidence (days)	525	478	469	394
Life table test	P=0.459N	P=0.022	P=0.318	P=0.344
Logistic regression test	P=0.333	P=0.030	P=0.225	P=0.199
Cochran-Armitage test	P=0.224			
Fisher exact test		P=0.020	P=0.201	P=0.106



**TABLE B3**  
**Statistical Analysis of Primary Neoplasms in Female Rats in the 2-Year Inhalation Study of Acetonitrile** (continued)

	0 ppm	100 ppm	200 ppm	400 ppm
<b>Mammary Gland: Carcinoma</b>				
Overall rate	2/48 (4%)	4/48 (8%)	3/48 (6%)	3/48 (6%)
Adjusted rate	8.7%	13.4%	11.5%	8.8%
Terminal rate	2/23 (9%)	1/21 (5%)	3/26 (12%)	1/29 (3%)
First incidence (days)	734 (T)	671	734 (T)	672
Life table test	P=0.536N	P=0.319	P=0.557	P=0.589
Logistic regression test	P=0.566	P=0.354	P=0.557	P=0.559
Cochran-Armitage test	P=0.500			
Fisher exact test		P=0.339	P=0.500	P=0.500
<b>Mammary Gland: Fibroadenoma or Carcinoma</b>				
Overall rate	17/48 (35%)	30/48 (63%)	23/48 (48%)	24/48 (50%)
Adjusted rate	59.6%	77.2%	66.2%	64.0%
Terminal rate	12/23 (52%)	13/21 (62%)	15/26 (58%)	16/29 (55%)
First incidence (days)	525	478	469	394
Life table test	P=0.388N	P=0.010	P=0.262	P=0.360
Logistic regression test	P=0.402	P=0.012	P=0.168	P=0.211
Cochran-Armitage test	P=0.263			
Fisher exact test		P=0.007	P=0.150	P=0.108
<b>Pituitary Gland (Pars Distalis): Adenoma</b>				
Overall rate	24/48 (50%)	26/48 (54%)	28/47 (60%)	29/45 (64%)
Adjusted rate	69.7%	73.0%	75.2%	77.9%
Terminal rate	13/23 (57%)	12/21 (57%)	17/26 (65%)	21/29 (72%)
First incidence (days)	530	600	534	599
Life table test	P=0.438N	P=0.327	P=0.422	P=0.554N
Logistic regression test	P=0.253	P=0.543	P=0.288	P=0.341
Cochran-Armitage test	P=0.084			
Fisher exact test		P=0.419	P=0.232	P=0.116
<b>Skin: Fibroma, Sarcoma, or Fibrous Histiocytoma</b>				
Overall rate	2/48 (4%)	3/48 (6%)	0/48 (0%)	1/48 (2%)
Adjusted rate	4.8%	12.8%	0.0%	3.4%
Terminal rate	0/23 (0%)	2/21 (10%)	0/26 (0%)	1/29 (3%)
First incidence (days)	310	706	- <sup>c</sup>	734 (T)
Life table test	P=0.199N	P=0.479	P=0.240N	P=0.453N
Logistic regression test	P=0.272N	P=0.451	P=0.326N	P=0.659N
Cochran-Armitage test	P=0.242N			
Fisher exact test		P=0.500	P=0.247N	P=0.500N
<b>Thyroid Gland (C-cell): Adenoma</b>				
Overall rate	3/48 (6%)	4/48 (8%)	4/48 (8%)	4/46 (9%)
Adjusted rate	10.5%	18.2%	15.4%	13.3%
Terminal rate	1/23 (4%)	3/21 (14%)	4/26 (15%)	3/29 (10%)
First incidence (days)	702	721	734 (T)	729
Life table test	P=0.542N	P=0.429	P=0.535	P=0.597
Logistic regression test	P=0.547	P=0.479	P=0.494	P=0.572
Cochran-Armitage test	P=0.420			
Fisher exact test		P=0.500	P=0.500	P=0.476

**TABLE B3**  
**Statistical Analysis of Primary Neoplasms in Female Rats in the 2-Year Inhalation Study of Acetonitrile** (continued)

	0 ppm	100 ppm	200 ppm	400 ppm
<b>Thyroid Gland (C-cell): Adenoma or Carcinoma</b>				
Overall rate	3/48 (6%)	5/48 (10%)	4/48 (8%)	4/46 (9%)
Adjusted rate	10.5%	22.7%	15.4%	13.3%
Terminal rate	1/23 (4%)	4/21 (19%)	4/26 (15%)	3/29 (10%)
First incidence (days)	702	721	734 (T)	729
Life table test	P=0.478N	P=0.291	P=0.535	P=0.597
Logistic regression test	P=0.534N	P=0.325	P=0.494	P=0.572
Cochran-Armitage test	P=0.473			
Fisher exact test		P=0.357	P=0.500	P=0.476
<b>Uterus: Stromal Polyp</b>				
Overall rate	7/48 (15%)	4/48 (8%)	9/48 (19%)	5/48 (10%)
Adjusted rate	27.7%	14.3%	30.5%	16.6%
Terminal rate	6/23 (26%)	2/21 (10%)	7/26 (27%)	4/29 (14%)
First incidence (days)	331	621	485	723
Life table test	P=0.273N	P=0.291N	P=0.484	P=0.236N
Logistic regression test	P=0.397N	P=0.243N	P=0.412	P=0.317N
Cochran-Armitage test	P=0.457N			
Fisher exact test		P=0.262N	P=0.392	P=0.379N
<b>All Organs: Mononuclear Cell Leukemia</b>				
Overall rate	18/48 (38%)	22/48 (46%)	20/48 (42%)	24/48 (50%)
Adjusted rate	46.4%	62.3%	55.6%	57.9%
Terminal rate	5/23 (22%)	9/21 (43%)	11/26 (42%)	12/29 (41%)
First incidence (days)	331	328	534	427
Life table test	P=0.491	P=0.261	P=0.513	P=0.417
Logistic regression test	P=0.158	P=0.227	P=0.403	P=0.101
Cochran-Armitage test	P=0.163			
Fisher exact test		P=0.267	P=0.417	P=0.152
<b>All Organs: Benign Neoplasms</b>				
Overall rate	38/48 (79%)	39/48 (81%)	38/48 (79%)	38/48 (79%)
Adjusted rate	100.0%	92.7%	90.3%	92.6%
Terminal rate	23/23 (100%)	18/21 (86%)	22/26 (85%)	26/29 (90%)
First incidence (days)	331	478	469	394
Life table test	P=0.069N	P=0.350	P=0.371N	P=0.115N
Logistic regression test	P=0.188N	P=0.405N	P=0.422N	P=0.190N
Cochran-Armitage test	P=0.512N			
Fisher exact test		P=0.500	P=0.599N	P=0.599N
<b>All Organs: Malignant Neoplasms</b>				
Overall rate	29/48 (60%)	28/48 (58%)	23/48 (48%)	27/48 (56%)
Adjusted rate	67.8%	74.0%	60.3%	63.8%
Terminal rate	10/23 (43%)	12/21 (57%)	12/26 (46%)	14/29 (48%)
First incidence (days)	310	328	292	427
Life table test	P=0.116N	P=0.545	P=0.154N	P=0.182N
Logistic regression test	P=0.384N	P=0.542N	P=0.173N	P=0.499N
Cochran-Armitage test	P=0.338N			
Fisher exact test		P=0.500N	P=0.153N	P=0.418N

**TABLE B3**  
**Statistical Analysis of Primary Neoplasms in Female Rats in the 2-Year Inhalation Study of Acetonitrile** (continued)

	0 ppm	100 ppm	200 ppm	400 ppm
<b>All Organs: Benign or Malignant Neoplasms</b>				
Overall rate	47/48 (98%)	46/48 (96%)	45/48 (94%)	46/48 (96%)
Adjusted rate	100.0%	97.9%	93.8%	97.9%
Terminal rate	23/23 (100%)	20/21 (95%)	23/26 (88%)	28/29 (97%)
First incidence (days)	310	328	292	394
Life table test	P=0.060N	P=0.489	P=0.274N	P=0.090N
Logistic regression test	P=0.339N	P=0.313N	P=0.248N	P=0.240N
Cochran-Armitage test	P=0.404N			
Fisher exact test		P=0.500N	P=0.308N	P=0.500N

(T) Terminal sacrifice

- <sup>a</sup> Number of neoplasm-bearing animals/number of animals examined. Denominator is number of animals examined microscopically for adrenal gland, clitoral gland, pituitary gland, and thyroid gland; for other tissues, denominator is number of animals necropsied.
- <sup>b</sup> Kaplan-Meier estimated neoplasm incidence at the end of the study after adjustment for intercurrent mortality
- <sup>c</sup> Observed incidence at terminal kill
- <sup>d</sup> Beneath the control incidence are the P values associated with the trend test. Beneath the exposed group incidence are the P values corresponding to pairwise comparisons between the controls and that exposed group. The life table test regards neoplasms in animals dying prior to terminal kill as being (directly or indirectly) the cause of death. The logistic regression test regards these lesions as nonfatal. The Cochran-Armitage and Fisher exact tests compare directly the overall incidence rates. For all tests, a negative trend or a lower incidence in an exposure group is indicated by N.
- <sup>e</sup> Not applicable; no neoplasms in animal group

**TABLE B4**  
**Summary of the Incidence of Nonneoplastic Lesions in Female Rats in the 2-Year Inhalation Study of Acetonitrile<sup>a</sup>**

	0 ppm	100 ppm	200 ppm	400 ppm
<b>Disposition Summary</b>				
Animals initially in study	56	56	56	56
<b>15-Month interim evaluation</b>	8	8	8	8
Early deaths				
Accidental death	1			
Moribund	24	25	21	14
Natural deaths		2	1	5
Survivors				
Terminal sacrifice	23	21	26	29
Animals examined microscopically	56	56	56	56
<b>15-Month Interim Evaluation</b>				
<b>Alimentary System</b>				
Esophagus	(8)	(8)	(8)	(8)
Mediastinum, cyst			1 (13%)	
Intestine large, colon	(8)	(8)	(8)	(8)
Inflammation, suppurative		1 (13%)		
Intestine large, rectum	(8)	(8)	(8)	(8)
Ulcer		1 (13%)		
Liver	(8)	(8)	(8)	(8)
Angiectasis				1 (13%)
Basophilic focus	6 (75%)	7 (88%)	5 (63%)	6 (75%)
Clear cell focus	1 (13%)			
Eosinophilic focus			1 (13%)	
Granuloma, multifocal		2 (25%)	1 (13%)	1 (13%)
Hepatodiaphragmatic nodule	1 (13%)	1 (13%)	1 (13%)	
Serosa, hemorrhage			1 (13%)	
Mesentery				(2)
Fat, inflammation, granulomatous				2 (100%)
Fat, necrosis				1 (50%)
Pancreas	(8)	(8)	(8)	(8)
Acinus, atrophy	1 (13%)	3 (38%)	6 (75%)	2 (25%)
Stomach, forestomach	(8)	(8)	(8)	(8)
Hyperplasia, squamous			1 (13%)	
<b>Cardiovascular System</b>				
Heart	(8)	(8)	(8)	(8)
Cardiomyopathy		2 (25%)		
<b>Endocrine System</b>				
Pituitary gland	(8)	(8)	(8)	(8)
Cyst	2 (25%)	2 (25%)		1 (13%)
Pars distalis, cyst				1 (13%)
Pars distalis, hyperplasia		2 (25%)		
Thyroid gland	(8)	(8)	(8)	(8)
Dilatation	1 (13%)			
C-cell, hyperplasia		1 (13%)		1 (13%)

<sup>a</sup> Number of animals examined microscopically at the site and the number of animals with lesion

TABLE B4

Summary of the Incidence of Nonneoplastic Lesions in Female Rats in the 2-Year Inhalation Study of Acetonitrile (continued)

	0 ppm	100 ppm	200 ppm	400 ppm
<b>15-Month Interim Evaluation</b> (continued)				
<b>Genital System</b>				
Clitoral gland	(8)	(8)	(8)	(8)
Ectasia			1 (13%)	
Inflammation, suppurative			1 (13%)	
Ovary	(8)	(8)	(8)	(8)
Cyst	2 (25%)		1 (13%)	
Uterus	(8)	(8)	(8)	(8)
Endometrium, hyperplasia			1 (13%)	
<b>Hematopoietic System</b>				
Lymph node		(1)	(1)	
Pancreatic, hemorrhage		1 (100%)		
Pancreatic, pigmentation			1 (100%)	
Lymph node, mandibular	(8)	(8)	(7)	(7)
Hyperplasia, lymphoid			2 (29%)	
Lymph node, mesenteric	(8)	(8)	(8)	(8)
Hemorrhage		1 (13%)		
Hyperplasia, lymphoid		1 (13%)		
Lymph node, mediastinal	(8)	(7)	(8)	(8)
Hemorrhage		1 (14%)		
Hyperplasia, lymphoid			1 (13%)	
Thymus	(8)	(8)	(7)	(8)
Hyperplasia, lymphoid			1 (14%)	
<b>Integumentary System</b>				
Skin	(8)	(8)	(8)	(8)
Acanthosis			1 (13%)	
Inflammation, granulomatous			1 (13%)	
Ulcer			1 (13%)	
Subcutaneous tissue, hemorrhage			1 (13%)	
<b>Musculoskeletal System</b>				
Bone	(8)	(8)	(8)	(8)
Periosteum, cranium, hemorrhage				1 (13%)
<b>Respiratory System</b>				
Larynx	(8)	(8)	(8)	(8)
Foreign body	2 (25%)		2 (25%)	1 (13%)
Hyperplasia			2 (25%)	1 (13%)
Inflammation, suppurative	2 (25%)		2 (25%)	
Metaplasia, squamous			1 (13%)	
Mineralization			1 (13%)	
Lung	(8)	(8)	(8)	(8)
Hemorrhage	8 (100%)	8 (100%)	8 (100%)	8 (100%)
Infiltration cellular, histiocyte	1 (13%)	1 (13%)	1 (13%)	1 (13%)
Pleura, fibrosis	1 (13%)			

TABLE B4

Summary of the Incidence of Nonneoplastic Lesions in Female Rats in the 2-Year Inhalation Study of Acetonitrile (continued)

	0 ppm	100 ppm	200 ppm	400 ppm
<b>15-Month Interim Evaluation</b> (continued)				
<b>Special Senses System</b>				
Eye	(1)	(1)	(2)	(1)
Cataract				1 (100%)
Hemorrhage	1 (100%)	1 (100%)	1 (50%)	1 (100%)
<b>Urinary System</b>				
Kidney	(8)	(8)	(8)	(8)
Nephropathy, chronic	3 (38%)	1 (13%)	1 (13%)	
Renal tubule, mineralization	5 (63%)	2 (25%)	3 (38%)	4 (50%)
<b>Systems Examined With No Lesions Observed</b>				
<b>General Body System</b>				
<b>Nervous System</b>				
<b>2-Year Study</b>				
<b>Alimentary System</b>				
Intestine large, colon	(47)	(47)	(48)	(45)
Lumen, parasite metazoan	2 (4%)			1 (2%)
Intestine large, rectum	(47)	(48)	(48)	(45)
Lumen, parasite metazoan	2 (4%)		6 (13%)	3 (7%)
Intestine large, cecum	(47)	(47)	(47)	(45)
Lumen, parasite metazoan		1 (2%)	2 (4%)	
Intestine small, jejunum	(47)	(47)	(48)	(45)
Inflammation, granulomatous		1 (2%)		
Intestine small, ileum	(47)	(47)	(46)	(45)
Inflammation, granulomatous		1 (2%)		
Liver	(48)	(48)	(48)	(46)
Atrophy		1 (2%)		
Basophilic focus	34 (71%)	34 (71%)	33 (69%)	36 (78%)
Clear cell focus	1 (2%)	2 (4%)	1 (2%)	
Degeneration, cystic	1 (2%)			1 (2%)
Granuloma, multifocal		2 (4%)	1 (2%)	2 (4%)
Hematopoietic cell proliferation	1 (2%)	1 (2%)		
Hepatodiaphragmatic nodule	6 (13%)	2 (4%)	7 (15%)	8 (17%)
Infarct	1 (2%)			
Mixed cell focus				2 (4%)
Vacuolization cytoplasmic	11 (23%)	14 (29%)	12 (25%)	20 (43%)
Bile duct, hyperplasia	2 (4%)			
Hepatocyte, degeneration, cystic		1 (2%)	1 (2%)	3 (7%)
Hepatocyte, hyperplasia	7 (15%)	9 (19%)	4 (8%)	10 (22%)
Hepatocyte, necrosis	1 (2%)		3 (6%)	
Portal, fibrosis	1 (2%)			
Serosa, cyst		1 (2%)		
Serosa, hemorrhage		1 (2%)		

**TABLE B4**  
**Summary of the Incidence of Nonneoplastic Lesions in Female Rats in the 2-Year Inhalation Study of Acetonitrile** (continued)

	0 ppm	100 ppm	200 ppm	400 ppm
<b>2-Year Study</b> (continued)				
<b>Alimentary System</b> (continued)				
Mesentery	(10)	(9)	(8)	(9)
Hemorrhage	1 (10%)	1 (11%)	2 (25%)	1 (11%)
Artery, inflammation		1 (11%)	1 (13%)	
Fat, inflammation, granulomatous	1 (10%)	6 (67%)	4 (50%)	5 (56%)
Fat, necrosis	7 (70%)	2 (22%)	4 (50%)	8 (89%)
Pancreas	(48)	(48)	(48)	(46)
Acinus, atrophy	14 (29%)	19 (40%)	23 (48%)	25 (54%)
Artery, inflammation			1 (2%)	1 (2%)
Salivary glands	(48)	(46)	(48)	(47)
Duct, mineralization	1 (2%)			
Stomach, forestomach	(48)	(48)	(47)	(46)
Diverticulum			2 (4%)	
Edema	2 (4%)	3 (6%)	5 (11%)	
Hyperplasia, basal cell			1 (2%)	2 (4%)
Hyperplasia, squamous	3 (6%)	6 (13%)	7 (15%)	7 (15%)
Inflammation, suppurative	2 (4%)	5 (10%)	4 (9%)	3 (7%)
Necrosis			1 (2%)	
Ulcer	2 (4%)	3 (6%)	5 (11%)	5 (11%)
Stomach, glandular	(47)	(48)	(48)	(46)
Mineralization				1 (2%)
Necrosis	1 (2%)			
<b>Cardiovascular System</b>				
Blood vessel	(48)	(48)	(48)	(47)
Aorta, inflammation			1 (2%)	
Aorta, mineralization				1 (2%)
Heart	(48)	(48)	(48)	(47)
Cardiomyopathy	2 (4%)		2 (4%)	2 (4%)
Thrombosis	1 (2%)	1 (2%)		1 (2%)
Endocardium, hyperplasia	1 (2%)			1 (2%)
<b>Endocrine System</b>				
Adrenal cortex	(48)	(48)	(48)	(46)
Hemorrhage	1 (2%)		1 (2%)	
Hyperplasia	1 (2%)	2 (4%)		
Mineralization				1 (2%)
Vacuolization cytoplasmic	6 (13%)	11 (23%)	5 (10%)	8 (17%)
Adrenal medulla	(48)	(48)	(47)	(47)
Angiectasis			1 (2%)	
Hyperplasia	5 (10%)	6 (13%)	3 (6%)	1 (2%)
Parathyroid gland	(44)	(44)	(44)	(45)
Hyperplasia			3 (7%)	1 (2%)
Pituitary gland	(48)	(48)	(47)	(45)
Cyst	11 (23%)	15 (31%)	14 (30%)	14 (31%)
Pars distalis, cyst	1 (2%)	1 (2%)		
Pars distalis, hemorrhage		1 (2%)		
Pars distalis, hyperplasia	9 (19%)	3 (6%)	3 (6%)	3 (7%)

**TABLE B4**  
**Summary of the Incidence of Nonneoplastic Lesions in Female Rats in the 2-Year Inhalation Study of Acetonitrile** (continued)

	0 ppm	100 ppm	200 ppm	400 ppm
<b>2-Year Study</b> (continued)				
<b>Endocrine System</b> (continued)				
Thyroid gland	(48)	(48)	(48)	(46)
Ultimobranchial cyst			1 (2%)	
C-cell, hyperplasia	26 (54%)	38 (79%)	36 (75%)	38 (83%)
<b>General Body System</b>				
None				
<b>Genital System</b>				
Clitoral gland	(46)	(42)	(47)	(45)
Ectasia	11 (24%)	4 (10%)	9 (19%)	14 (31%)
Hyperplasia	2 (4%)	4 (10%)	4 (9%)	3 (7%)
Inflammation, suppurative	4 (9%)	3 (7%)	1 (2%)	6 (13%)
Ovary	(48)	(48)	(48)	(47)
Cyst	2 (4%)	3 (6%)	1 (2%)	5 (11%)
Inflammation, granulomatous		1 (2%)		
Uterus	(48)	(48)	(48)	(47)
Hemorrhage	1 (2%)			
Thrombosis	1 (2%)			
Cervix, endometrium, hyperplasia		1 (2%)	1 (2%)	
Endometrium, hyperplasia	1 (2%)		1 (2%)	
<b>Hematopoietic System</b>				
Bone marrow	(48)	(48)	(48)	(46)
Hyperplasia, RE cell	1 (2%)	3 (6%)	2 (4%)	1 (2%)
Myelofibrosis		2 (4%)		
Lymph node	(7)	(5)	(8)	(8)
Axillary, hyperplasia, lymphoid			1 (13%)	
Iliac, pigmentation			1 (13%)	
Lumbar, pigmentation	1 (14%)			
Renal, hemorrhage		1 (20%)	1 (13%)	
Lymph node, bronchial	(43)	(39)	(41)	(40)
Hemorrhage	4 (9%)	1 (3%)		2 (5%)
Inflammation, suppurative	1 (2%)			
Lymph node, mandibular	(46)	(46)	(45)	(42)
Hemorrhage	1 (2%)			
Hyperplasia, lymphoid	2 (4%)	1 (2%)	2 (4%)	
Lymph node, mesenteric	(46)	(47)	(47)	(47)
Hemorrhage		2 (4%)		2 (4%)
Hyperplasia, lymphoid	2 (4%)			
Inflammation, granulomatous		1 (2%)		
Lymph node, mediastinal	(48)	(46)	(45)	(46)
Hemorrhage	11 (23%)	6 (13%)	3 (7%)	11 (24%)
Pigmentation				1 (2%)



**TABLE B4**  
**Summary of the Incidence of Nonneoplastic Lesions in Female Rats in the 2-Year Inhalation Study of Acetonitrile (continued)**

	0 ppm	100 ppm	200 ppm	400 ppm
<b>2-Year Study (continued)</b>				
<b>Hematopoietic System (continued)</b>				
Spleen	(48)	(48)	(48)	(45)
Developmental malformation				1 (2%)
Fibrosis	1 (2%)	2 (4%)	1 (2%)	3 (7%)
Hematopoietic cell proliferation				1 (2%)
Hemorrhage	1 (2%)		2 (4%)	
Hyperplasia, RE cell	2 (4%)	3 (6%)	1 (2%)	
Necrosis	1 (2%)	1 (2%)	1 (2%)	1 (2%)
Thymus	(48)	(48)	(48)	(47)
Hemorrhage		1 (2%)		
<b>Integumentary System</b>				
Mammary gland	(48)	(48)	(48)	(47)
Galactocele		2 (4%)	2 (4%)	
Epithelium, hyperplasia			1 (2%)	
Skin	(48)	(48)	(48)	(48)
Acanthosis		1 (2%)		
Inflammation, granulomatous			1 (2%)	1 (2%)
Inflammation, suppurative	1 (2%)	2 (4%)		
Ulcer		2 (4%)		2 (4%)
Subcutaneous tissue, necrosis				1 (2%)
<b>Musculoskeletal System</b>				
Bone	(47)	(48)	(48)	(47)
Fibrosis				1 (2%)
Vertebra, fracture	1 (2%)			
<b>Nervous System</b>				
Brain	(48)	(48)	(48)	(47)
Hemorrhage	4 (8%)	5 (10%)	8 (17%)	2 (4%)
Hydrocephalus	4 (8%)	6 (13%)	3 (6%)	5 (11%)
Necrosis	1 (2%)			
Spinal cord	(1)			
Hemorrhage	1 (100%)			
<b>Respiratory System</b>				
Larynx	(47)	(48)	(48)	(46)
Foreign body	6 (13%)	2 (4%)	2 (4%)	3 (7%)
Hyperplasia	5 (11%)	1 (2%)	1 (2%)	3 (7%)
Inflammation, suppurative	3 (6%)		4 (8%)	3 (7%)
Metaplasia, squamous	7 (15%)	5 (10%)	6 (13%)	3 (7%)

**TABLE B4**  
**Summary of the Incidence of Nonneoplastic Lesions in Female Rats in the 2-Year Inhalation Study of Acetonitrile** (continued)

	0 ppm	100 ppm	200 ppm	400 ppm
<b>2-Year Study</b> (continued)				
<b>Respiratory System</b> (continued)				
Lung	(48)	(48)	(48)	(46)
Hemorrhage	35 (73%)	29 (60%)	32 (67%)	30 (65%)
Infiltration cellular, histiocyte	10 (21%)	16 (33%)	16 (33%)	12 (26%)
Metaplasia, osseous			1 (2%)	
Alveolar epithelium, hyperplasia	6 (13%)	5 (10%)	2 (4%)	1 (2%)
Alveolus, fibrosis	2 (4%)	1 (2%)	1 (2%)	
Alveolus, inflammation, chronic	3 (6%)	1 (2%)		1 (2%)
Alveolus, inflammation, suppurative	2 (4%)			
Pleura, fibrosis	2 (4%)	2 (4%)	2 (4%)	1 (2%)
Nose	(47)	(47)	(48)	(46)
Foreign body	2 (4%)	5 (11%)	1 (2%)	3 (7%)
Hemorrhage		1 (2%)	1 (2%)	1 (2%)
Inflammation, chronic	1 (2%)		1 (2%)	2 (4%)
Inflammation, suppurative	1 (2%)	2 (4%)	3 (6%)	2 (4%)
Goblet cell, respiratory epithelium, hypertrophy	3 (6%)	2 (4%)	2 (4%)	4 (9%)
Nasolacrimal duct, inflammation, suppurative		3 (6%)		2 (4%)
Olfactory epithelium, metaplasia				1 (2%)
Respiratory epithelium, hyperplasia	2 (4%)	2 (4%)	2 (4%)	1 (2%)
Respiratory epithelium, metaplasia, squamous			1 (2%)	1 (2%)
Trachea	(48)	(48)	(48)	(45)
Epithelium, hyperplasia				1 (2%)
<b>Special Senses System</b>				
Eye	(3)	(1)	(2)	(3)
Cataract	1 (33%)		2 (100%)	
Hemorrhage	1 (33%)		1 (50%)	
Retina, atrophy			1 (50%)	
<b>Urinary System</b>				
Kidney	(48)	(48)	(48)	(46)
Infarct		1 (2%)		
Nephropathy, chronic	37 (77%)	37 (77%)	37 (77%)	40 (87%)
Cortex, necrosis	5 (10%)	2 (4%)	5 (10%)	5 (11%)
Pelvis, transitional epithelium, hyperplasia		1 (2%)		
Renal tubule, inflammation, suppurative		1 (2%)		
Renal tubule, mineralization	39 (81%)	40 (83%)	45 (94%)	37 (80%)
Renal tubule, pigmentation, hemosiderin		1 (2%)		
Urinary bladder	(48)	(48)	(47)	(45)
Transitional epithelium, hyperplasia		1 (2%)		

**APPENDIX C**  
**SUMMARY OF LESIONS IN MALE MICE**  
**IN THE 2-YEAR INHALATION STUDY**  
**OF ACETONITRILE**

<b>TABLE C1</b>	<b>Summary of the Incidence of Neoplasms in Male Mice in the 2-Year Inhalation Study of Acetonitrile .....</b>	<b>144</b>
<b>TABLE C2</b>	<b>Individual Animal Tumor Pathology of Male Mice in the 2-Year Inhalation Study of Acetonitrile .....</b>	<b>148</b>
<b>TABLE C3</b>	<b>Statistical Analysis of Primary Neoplasms in Male Mice in the 2-Year Inhalation Study of Acetonitrile .....</b>	<b>164</b>
<b>TABLE C4a</b>	<b>Historical Incidence of Alveolar/bronchiolar Neoplasms in Untreated Male B6C3F<sub>1</sub> Mice .....</b>	<b>168</b>
<b>TABLE C4b</b>	<b>Historical Incidence of Hepatocellular Neoplasms in Untreated Male B6C3F<sub>1</sub> Mice .....</b>	<b>168</b>
<b>TABLE C4c</b>	<b>Historical Incidence of Forestomach Squamous Cell Papilloma in Untreated Male B6C3F<sub>1</sub> Mice .....</b>	<b>169</b>
<b>TABLE C5</b>	<b>Summary of the Incidence of Nonneoplastic Lesions in Male Mice in the 2-Year Inhalation Study of Acetonitrile .....</b>	<b>170</b>

**TABLE C1**  
**Summary of the Incidence of Neoplasms in Male Mice in the 2-Year Inhalation Study of Acetonitrile<sup>a</sup>**

	0 ppm	50 ppm	100 ppm	200 ppm
<b>Disposition Summary</b>				
Animals initially in study	60	60	60	60
<b>15-Month interim evaluation</b>				
Early deaths				
Moribund	13	14	16	6
Natural deaths	5	4	2	1
Survivors				
Terminal sacrifice	32	32	32	43
Animals examined microscopically	60	60	60	60
<b>15-Month Interim Evaluation</b>				
<b>Alimentary System</b>				
Liver	(10)	(10)	(10)	(10)
Hepatocellular carcinoma	1 (10%)	3 (30%)		
Hepatocellular adenoma	1 (10%)	1 (10%)	2 (20%)	1 (10%)
Hepatocellular adenoma, multiple	1 (10%)			
<b>Endocrine System</b>				
Thyroid gland	(10)	(10)	(10)	(10)
Follicular cell, adenoma		2 (20%)		
<b>Respiratory System</b>				
Lung	(10)	(10)	(10)	(10)
Alveolar/bronchiolar adenoma	1 (10%)	2 (20%)	2 (20%)	3 (30%)
Alveolar/bronchiolar adenoma, multiple		1 (10%)		
Alveolar/bronchiolar carcinoma	2 (20%)	1 (10%)		
<b>Systems Examined With No Neoplasms Observed</b>				
<b>Cardiovascular System</b>				
<b>General Body System</b>				
<b>Genital System</b>				
<b>Hematopoietic System</b>				
<b>Integumentary System</b>				
<b>Musculoskeletal System</b>				
<b>Nervous System</b>				
<b>Special Senses System</b>				
<b>Urinary System</b>				
<b>2-Year Study</b>				
<b>Alimentary System</b>				
Intestine large, rectum	(48)	(50)	(48)	(49)
Anus, leiomyosarcoma		1 (2%)		
Intestine small, duodenum	(47)	(48)	(48)	(48)
Adenoma	1 (2%)			

**TABLE C1**  
**Summary of the Incidence of Neoplasms in Male Mice in the 2-Year Inhalation Study of Acetonitrile** (continued)

	0 ppm	50 ppm	100 ppm	200 ppm
<b>2-Year Study</b> (continued)				
<b>Alimentary System</b> (continued)				
Intestine small, jejunum	(45)	(48)	(47)	(49)
Carcinoma	1 (2%)			1 (2%)
Liver	(50)	(50)	(49)	(50)
Hemangioma				1 (2%)
Hemangiosarcoma		1 (2%)	1 (2%)	1 (2%)
Hemangiosarcoma, multiple	1 (2%)	2 (4%)		2 (4%)
Hepatocellular carcinoma	3 (6%)	8 (16%)	7 (14%)	6 (12%)
Hepatocellular carcinoma, multiple	4 (8%)	3 (6%)	6 (12%)	1 (2%)
Hepatocellular adenoma	10 (20%)	10 (20%)	13 (27%)	9 (18%)
Hepatocellular adenoma, multiple	3 (6%)	2 (4%)	5 (10%)	1 (2%)
Histiocytic sarcoma		1 (2%)		
Bile duct, carcinoma				1 (2%)
Mesentery	(3)	(2)	(3)	(3)
Sarcoma, metastatic, skin	1 (33%)			
Fat, hemangioma			1 (33%)	1 (33%)
Pancreas	(49)	(50)	(48)	(50)
Adenocarcinoma		1 (2%)		
Salivary glands	(50)	(50)	(48)	(50)
Stomach, forestomach	(49)	(50)	(48)	(50)
Squamous cell papilloma			1 (2%)	2 (4%)
Stomach, glandular	(49)	(50)	(48)	(50)
Carcinoma, metastatic, pancreas		1 (2%)		
<b>Cardiovascular System</b>				
None				
<b>Endocrine System</b>				
Adrenal cortex	(48)	(50)	(48)	(50)
Adenoma	1 (2%)			
Capsule, adenoma	1 (2%)	4 (8%)		1 (2%)
Adrenal medulla	(49)	(50)	(47)	(50)
Pheochromocytoma benign	1 (2%)		1 (2%)	
Islets, pancreatic	(47)	(50)	(48)	(50)
Adenoma		1 (2%)		1 (2%)
Pituitary gland	(46)	(48)	(46)	(49)
Pars intermedia, adenoma	1 (2%)			1 (2%)
Thyroid gland	(49)	(50)	(48)	(50)
C-cell, adenoma	1 (2%)			
Follicular cell, adenoma	2 (4%)			
<b>General Body System</b>				
None				
<b>Genital System</b>				
Testes	(50)	(50)	(49)	(50)
Interstitial cell, adenoma		1 (2%)		

**TABLE C1**  
**Summary of the Incidence of Neoplasms in Male Mice in the 2-Year Inhalation Study of Acetonitrile** (continued)

	0 ppm	50 ppm	100 ppm	200 ppm
<b>2-Year Study</b> (continued)				
<b>Hematopoietic System</b>				
Bone marrow	(49)	(50)	(48)	(50)
Hemangioma		1 (2%)		
Hemangiosarcoma		1 (2%)		1 (2%)
Lymph node	(3)	(2)	(2)	
Lymph node, bronchial	(38)	(37)	(38)	(41)
Carcinoma, metastatic, pancreas		1 (3%)		
Lymph node, mandibular	(35)	(33)	(29)	(36)
Lymph node, mesenteric	(48)	(49)	(47)	(49)
Hemangiosarcoma	1 (2%)			
Lymph node, mediastinal	(42)	(38)	(35)	(33)
Carcinoma, metastatic, pancreas		1 (3%)		
Hemangiosarcoma				1 (3%)
Sarcoma, metastatic, skin	1 (2%)			
Spleen	(49)	(50)	(48)	(50)
Hemangiosarcoma				1 (2%)
Thymus	(44)	(45)	(38)	(47)
Carcinoma, metastatic, pancreas		1 (2%)		
Hemangiosarcoma	1 (2%)			
<b>Integumentary System</b>				
Skin	(50)	(49)	(49)	(50)
Basal cell carcinoma			1 (2%)	
Prepuce, squamous cell carcinoma	1 (2%)			
Subcutaneous tissue, sarcoma	1 (2%)			
<b>Musculoskeletal System</b>				
None				
<b>Nervous System</b>				
None				
<b>Respiratory System</b>				
Lung	(50)	(50)	(48)	(50)
Alveolar/bronchiolar adenoma	4 (8%)	9 (18%)	6 (13%)	17 (34%)
Alveolar/bronchiolar adenoma, multiple	2 (4%)		2 (4%)	1 (2%)
Alveolar/bronchiolar carcinoma	4 (8%)	6 (12%)	4 (8%)	4 (8%)
Alveolar/bronchiolar carcinoma, multiple			2 (4%)	
Carcinoma, metastatic, pancreas		1 (2%)		
Hemangiosarcoma	1 (2%)			
Hepatocellular carcinoma		1 (2%)		
Hepatocellular carcinoma, metastatic, liver	4 (8%)	2 (4%)	5 (10%)	
Histiocytic sarcoma		1 (2%)		
Sarcoma, metastatic, skin	1 (2%)			
Mediastinum, hemangioma		1 (2%)		

TABLE C1  
Summary of the Incidence of Neoplasms in Male Mice in the 2-Year Inhalation Study of Acetonitrile (continued)

	0 ppm	50 ppm	100 ppm	200 ppm
<b>2-Year Study</b> (continued)				
<b>Special Senses System</b>				
Harderian gland	(5)	(5)	(1)	(2)
Adenoma	5 (100%)	4 (80%)	1 (100%)	2 (100%)
<b>Urinary System</b>				
Kidney	(49)	(50)	(48)	(50)
Pelvis, hemangioma	1 (2%)			
<b>Systemic Lesions</b>				
Multiple organs <sup>b</sup>	(50)	(50)	(50)	(50)
Histiocytic sarcoma		1 (2%)		
Lymphoma malignant lymphocytic	1 (2%)		1 (2%)	
Lymphoma malignant mixed	2 (4%)	3 (6%)	3 (6%)	2 (4%)
<b>Neoplasm Summary</b>				
Total animals with primary neoplasms <sup>c</sup>				
15-Month interim evaluation	4	6	3	3
2-Year study	32	38	37	35
Total primary neoplasms				
15-Month interim evaluation	6	10	4	4
2-Year study	54	61	55	58
Total animals with benign neoplasms				
15-Month interim evaluation	2	4	3	3
2-Year study	24	25	25	28
Total benign neoplasms				
15-Month interim evaluation	3	6	4	4
2-Year study	33	33	30	37
Total animals with malignant neoplasms				
15-Month interim evaluation	3	4		
2-Year study	18	23	19	18
Total malignant neoplasms				
15-Month interim evaluation	3	4		
2-Year study	21	28	25	21
Total animals with metastatic neoplasms				
2-Year study	5	3	5	
Total metastatic neoplasms				
2-Year study	7	7	5	

<sup>a</sup> Number of animals examined microscopically at the site and the number of animals with neoplasm

<sup>b</sup> Number of animals with any tissue examined microscopically

<sup>c</sup> Primary neoplasms: all neoplasms except metastatic neoplasms

**TABLE C2**  
**Individual Animal Tumor Pathology of Male Mice in the 2-Year Inhalation Study of Acetonitrile: 0 ppm**

<b>Number of Days on Study</b>	4 4 5 5 5 5 5 5 6 6 6 6 6 6 7 7 7 7 7 7 7 7 7 7
	3 5 4 4 6 8 9 9 9 2 3 5 7 7 9 1 1 2 3 3 3 3 3 3 3
	7 7 6 8 3 1 5 5 8 3 7 0 5 8 8 4 6 9 3 3 3 3 3 3 3
<b>Carcass ID Number</b>	0 0
	5 2 1 4 2 5 2 4 1 2 2 3 2 4 0 0 2 3 0 0 0 0 1 1 1
	9 3 0 6 1 2 8 9 7 4 7 8 5 0 1 7 6 6 2 4 5 8 1 2 3
<b>Alimentary System</b>	
Esophagus	+ +
Gallbladder	+ + M + M + + + A + M + A + + + + + + + + + + + +
Intestine large, colon	+ + + + + + + + A + + + A + + + + + + + + + + + +
Intestine large, rectum	+ + + + + + + + A + + + A + + + + + + + + + + + +
Intestine large, cecum	+ + + + + + + + A + + + M + + + A + + + + + + + +
Intestine small, duodenum	+ + + + A + + + A + + + A + + + + + + + + + + + +
Adenoma	
Intestine small, jejunum	+ + + + A + + + M + + + A + + + + A + + + + + + +
Carcinoma	
Intestine small, ileum	+ + + + A + + + M + + + A + + M + + + + + + + + + +
Liver	+ +
Hemangiosarcoma, multiple	
Hepatocellular carcinoma	
Hepatocellular carcinoma, multiple	X X X
Hepatocellular adenoma	
Hepatocellular adenoma, multiple	
Mesentery	
Sarcoma, metastatic, skin	+ X
Pancreas	+ + + + + + + + A + + + + + + + + + + + + + + + +
Salivary glands	+ +
Stomach, forestomach	+ + + + + + + + A + + + + + + + + + + + + + + + +
Stomach, glandular	+ + + + + + + + A + + + + + + + + + + + + + + + +
Tooth	+ + +
<b>Cardiovascular System</b>	
Blood vessel	+ + + + + + + + + + + + M + + + + + + + + + + + +
Heart	+ +
<b>Endocrine System</b>	
Adrenal cortex	+ + + + + + + + A + + + + + + + + + + + + + + + +
Adenoma	
Capsule, adenoma	
Adrenal medulla	+ + + + + + + + A + + + + + + + + + + + + + + + +
Pheochromocytoma benign	
Islets, pancreatic	+ + + + + + + + A + + M + + + + + + + + + + + + +
Parathyroid gland	M + M M M + M M M + + + M + + + M + + + + + + + +
Pituitary gland	+ + + + + + + + + + + + M + + + + + + + + + + + + +
Pars intermedia, adenoma	
Thyroid gland	+ + + + + + + + A + + + + + + + + + + + + + + + +
C-cell, adenoma	X
Follicular cell, adenoma	
<b>General Body System</b>	
Tissue NOS	
<b>Genital System</b>	
Epididymis	+ +
Preputial gland	+ M +
Prostate	+ + M + + + + + + + + + + + + + + + + M + + + +
Seminal vesicle	+ + + + + + + + A + + + + + + + + + + + + + + + +
Testes	+ +

+ : Tissue examined microscopically  
 A : Autolysis precludes examination

M : Missing tissue  
 I : Insufficient tissue

X : Lesion present  
 Blank : Not examined



TABLE C2
Individual Animal Tumor Pathology of Male Mice in the 2-Year Inhalation Study of Acetonitrile: 0 ppm (continued)

Table with columns for Carcass ID Number, Number of Days on Study, and various tumor types (Alimentary System, Cardiovascular System, Endocrine System, General Body System, Genital System) with counts and symbols (+, X, M).

**TABLE C2**  
**Individual Animal Tumor Pathology of Male Mice in the 2-Year Inhalation Study of Acetonitrile: 0 ppm (continued)**

<b>Number of Days on Study</b>	4 4 5 5 5 5 5 5 5 5 6 6 6 6 6 6 7 7 7 7 7 7 7 7 7 7
	3 5 4 4 6 8 9 9 9 9 2 3 5 7 7 9 1 1 2 3 3 3 3 3 3 3
	7 7 6 8 3 1 5 5 8 3 7 0 5 8 8 4 6 9 3 3 3 3 3 3 3 3
<b>Carcass ID Number</b>	0 0
	5 2 1 4 2 5 2 4 1 2 2 3 2 4 0 0 2 3 0 0 0 0 0 1 1 1
	9 3 0 6 1 2 8 9 7 4 7 8 5 0 1 7 6 6 2 4 5 8 1 2 3
<b>Hematopoietic System</b>	
Bone marrow	+ + + + + + + + A + + + + + + + + + + + + + + +
Lymph node	+ +
Lymph node, bronchial	M M M + M + M + M + + M M M + + + + + + + + + +
Lymph node, mandibular	+ + + M M M + + M + + + M + + + + + + + + + + M + +
Lymph node, mesenteric	+ + + + + + + + A + + + + + + + + + + + + + + + M + +
Hemangiosarcoma	+ X
Lymph node, mediastinal	+ + M M + + + + M M + + + + + + + + M + + + + + + +
Sarcoma, metastatic, skin	X
Spleen	+ + + + + + + + A + + + + + + + + + + + + + + + +
Thymus	+ M + + + + M + A M + + + + + + + + + + M + + + + +
Hemangiosarcoma	+ X
<b>Integumentary System</b>	
Mammary gland	M M
Skin	+ +
Prepuce, squamous cell carcinoma	
Subcutaneous tissue, sarcoma	X
<b>Musculoskeletal System</b>	
Bone	+ +
<b>Nervous System</b>	
Brain	+ +
<b>Respiratory System</b>	
Larynx	+ + + + + + + + A + + + + + + + + + + + + + + + + + +
Lung	+ +
Alveolar/bronchiolar adenoma	
Alveolar/bronchiolar adenoma, multiple	
Alveolar/bronchiolar carcinoma	
Hemangiosarcoma	
Hepatocellular carcinoma, metastatic, liver	
Sarcoma, metastatic, skin	
Nose	+ +
Trachea	+ + + + + + + + A + + + + + + + + + + + + + + + + + + +
<b>Special Senses System</b>	
Harderian gland	+ +
Adenoma	X X X
<b>Urinary System</b>	
Kidney	+ + + + + + + + A + + + + + + + + + + + + + + + + + +
Pelvis, hemangioma	
Urinary bladder	+ + + + + + + + A + + + + + + + + + + + + + + + + + +
<b>Systemic Lesions</b>	
Multiple organs	+ +
Lymphoma malignant lymphocytic	
Lymphoma malignant mixed	







**TABLE C2**  
**Individual Animal Tumor Pathology of Male Mice in the 2-Year Inhalation Study of Acetonitrile: 50 ppm (continued)**

<b>Number of Days on Study</b>	4 4 5 5 5 5 6 6 6 6 6 6 6 6 7 7 7 7 7 7 7 7 7
	2 3 7 8 9 9 0 2 3 4 5 6 6 7 9 0 1 1 3 3 3 3 3 3 3
	6 4 1 3 5 5 2 3 6 8 8 4 4 4 2 0 1 4 4 4 4 4 4 4 4
<b>Carcass ID Number</b>	1 1
	3 3 7 4 6 7 2 3 5 4 7 4 7 3 8 6 7 3 2 2 2 2 2 2 2
	7 5 1 7 3 9 8 0 4 9 7 3 4 8 0 1 3 2 1 2 4 5 6 7 9
<b>Hematopoietic System</b>	
Bone marrow	+ +
Hemangioma	
Hemangiosarcoma	X
Lymph node	
Lymph node, bronchial	+ + + + M + M + + + + + + + + + + M M + + + + + + +
Carcinoma, metastatic, pancreas	
	X
Lymph node, mandibular	M + + + M M + + + + + M + M + M + M + + M M M + +
Lymph node, mesenteric	+ + + + M +
Lymph node, mediastinal	+ + M + + + + + + + + + + + + + + + + M M + + M +
Carcinoma, metastatic, pancreas	
	X
Spleen	+ +
Thymus	+ + + M M + M + + + + + + + + + + M M + + + + + + +
Carcinoma, metastatic, pancreas	
	X
<b>Integumentary System</b>	
Mammary gland	M M
Skin	+ + + + + + + + + + + + + + + M + + + + + + + + + + +
<b>Musculoskeletal System</b>	
Bone	+ +
Skeletal muscle	
<b>Nervous System</b>	
Brain	+ +
<b>Respiratory System</b>	
Larynx	+ +
Lung	+ +
Alveolar/bronchiolar adenoma	
	X
Alveolar/bronchiolar carcinoma	X
Carcinoma, metastatic, pancreas	X X X
Hepatocellular carcinoma	X
Hepatocellular carcinoma, metastatic, liver	X
Histiocytic sarcoma	
Mediastinum, hemangioma	X
Nose	+ +
Trachea	+ +
<b>Special Senses System</b>	
Ear	+
Harderian gland	
Adenoma	+ +
	X
<b>Urinary System</b>	
Kidney	+ +
Urinary bladder	+ + + + + + + + + + + + + + + + + M + + + + + + + +
<b>Systemic Lesions</b>	
Multiple organs	+ +
Histiocytic sarcoma	
Lymphoma malignant mixed	X X



TABLE C2
Individual Animal Tumor Pathology of Male Mice in the 2-Year Inhalation Study of Acetonitrile: 100 ppm

Table with 25 columns representing individual mice and rows for various tumor types across different systems (Alimentary, Cardiovascular, Endocrine, General Body, Genital). Entries include '+' for no tumor, 'A' for adenoma, 'M' for mesenchymal tumor, and 'X' for carcinoma/sarcoma.













**TABLE C2**  
**Individual Animal Tumor Pathology of Male Mice in the 2-Year Inhalation Study of Acetonitrile: 200 ppm (continued)**

Number of Days on Study	5 5 6 6 6 7 7 7 7 7 7 7 7 7 7 7 7 7 7 7 7 7 7 7
	3 5 4 6 9 0 2 3 3 3 3 3 3 3 3 3 3 3 3 3 3 3 3 3
	2 4 3 5 2 1 7 3 3 3 3 3 3 3 3 3 3 3 3 3 3 3 3 3
Carcass ID Number	3 4 3 3 4 3 3 3 3 3 3 3 3 3 3 3 3 3 3 3 3 3 3 3
	7 0 6 6 1 9 7 6 6 6 6 7 7 7 7 8 8 8 8 8 8 8 8 9
	0 6 8 1 7 3 5 2 3 5 6 2 3 4 8 0 1 2 3 4 5 6 8 9 0
<b>Hematopoietic System</b>	
Bone marrow	+ +
Hemangiosarcoma	X
Lymph node, bronchial	+ + + M + + + M M M + + + + + + + + + + + + + + +
Lymph node, mandibular	M + M M + + + + M M + + I + M + + + + + + M + M
Lymph node, mesenteric	+ +
Lymph node, mediastinal	+ M + M M + M I + + M M + + + M + M + M + + + M +
Hemangiosarcoma	
Spleen	+ +
Hemangiosarcoma	
Thymus	+ + M + M +
<b>Integumentary System</b>	
Mammary gland	M M
Skin	+ +
<b>Musculoskeletal System</b>	
Bone	+ +
<b>Nervous System</b>	
Brain	+ +
<b>Respiratory System</b>	
Larynx	+ +
Lung	+ +
Alveolar/bronchiolar adenoma	X X
Alveolar/bronchiolar adenoma, multiple	
Alveolar/bronchiolar carcinoma	
Nose	+ +
Trachea	+ +
<b>Special Senses System</b>	
Harderian gland	
Adenoma	+ X
<b>Urinary System</b>	
Kidney	+ +
Urinary Bladder	+ + + + + + + + + + +
<b>Systemic Lesions</b>	
Multiple organs	+ +
Lymphoma malignant mixed	X X

**TABLE C2**  
**Individual Animal Tumor Pathology of Male Mice in the 2-Year Inhalation Study of Acetonitrile: 200 ppm (continued)**

Number of Days on Study	7 7	
	3 3	
	3 3	
Carcass ID Number	3 3 3 3 3 3 3 4 4 4 4 4 4 4 4 4 4 4 4 4 4 4 4 4	Total
	9 9 9 9 9 9 9 0 0 0 0 0 0 0 0 1 1 1 1 1 1 1 1 1 2	Tissues/
	1 2 4 5 6 7 9 0 1 3 4 5 7 8 9 0 1 2 3 4 5 6 8 9 0	Tumors
<b>Hematopoietic System</b>		
Bone marrow	+ +	50
Hemangiosarcoma		1
Lymph node, bronchial	+ M + + + + + + M + + + M + M + + + + + + + + + + M	41
Lymph node, mandibular	M + + + + + + + M + M + + M + + + + M + + + + + + +	36
Lymph node, mesenteric	+ + + + + + + + + + + + + + + + + + M + + + + + + +	49
Lymph node, mediastinal	+ + + + + M M + + + + + + + + + + I + + + + + M M I	33
Hemangiosarcoma	X	1
Spleen	+ +	50
Hemangiosarcoma		1
Thymus	+ + + + + + + + M + + + + + + + + + + + + + + + + +	47
<b>Integumentary System</b>		
Mammary gland	M M	
Skin	+ +	50
<b>Musculoskeletal System</b>		
Bone	+ +	50
<b>Nervous System</b>		
Brain	+ +	50
<b>Respiratory System</b>		
Larynx	+ +	50
Lung	+ +	50
Alveolar/bronchiolar adenoma	X X	17
Alveolar/bronchiolar adenoma, multiple		1
Alveolar/bronchiolar carcinoma	X X	4
Nose	+ +	50
Trachea	+ +	50
<b>Special Senses System</b>		
Harderian gland		2
Adenoma		2
<b>Urinary System</b>		
Kidney	+ +	50
Urinary bladder	+ +	50
<b>Systemic Lesions</b>		
Multiple organs	+ +	50
Lymphoma malignant mixed		2

**TABLE C3**  
**Statistical Analysis of Primary Neoplasms in Male Mice in the 2-Year Inhalation Study of Acetonitrile**

	0 ppm	50 ppm	100 ppm	200 ppm
<b>Adrenal Cortex: Adenoma</b>				
Overall rate <sup>a</sup>	2/49 (4%)	4/50 (8%)	0/48 (0%)	1/50 (2%)
Adjusted rate <sup>b</sup>	6.3%	12.5%	0.0%	2.3%
Terminal rate <sup>c</sup>	2/32 (6%)	4/32 (13%)	0/32 (0%)	1/43 (2%)
First incidence (days)	733 (T)	733 (T)	— <sup>e</sup>	733 (T)
Life table test <sup>d</sup>	P=0.130N	P=0.335	P=0.238N	P=0.397N
Logistic regression test <sup>d</sup>	P=0.130N	P=0.335	P=0.238N	P=0.397N
Cochran-Armitage test <sup>d</sup>	P=0.197N			
Fisher exact test <sup>d</sup>		P=0.349	P=0.253N	P=0.492N
<b>Harderian Gland: Adenoma</b>				
Overall rate	5/50 (10%)	4/50 (8%)	1/50 (2%)	2/50 (4%)
Adjusted rate	12.2%	11.4%	3.1%	4.5%
Terminal rate	2/32 (6%)	3/32 (9%)	1/32 (3%)	1/43 (2%)
First incidence (days)	437	602	733 (T)	727
Life table test	P=0.073N	P=0.492N	P=0.106N	P=0.156N
Logistic regression test	P=0.150N	P=0.514N	P=0.102N	P=0.418N
Cochran-Armitage test	P=0.114N			
Fisher exact test		P=0.500N	P=0.102N	P=0.218N
<b>Liver: Hemangiosarcoma</b>				
Overall rate	1/50 (2%)	3/50 (6%)	1/49 (2%)	3/50 (6%)
Adjusted rate	3.0%	9.4%	2.9%	6.4%
Terminal rate	0/32 (0%)	3/32 (9%)	0/32 (0%)	0/43 (0%)
First incidence (days)	729	733 (T)	720	554
Life table test	P=0.431	P=0.304	P=0.760	P=0.387
Logistic regression test	P=0.321	P=0.295	P=0.763	P=0.221
Cochran-Armitage test	P=0.312			
Fisher exact test		P=0.309	P=0.747	P=0.309
<b>Liver: Hepatocellular Adenoma</b>				
Overall rate	13/50 (26%)	12/50 (24%)	18/49 (37%)	10/50 (20%)
Adjusted rate	35.0%	31.7%	49.1%	22.2%
Terminal rate	9/32 (28%)	8/32 (25%)	14/32 (44%)	8/43 (19%)
First incidence (days)	563	434	595	701
Life table test	P=0.114N	P=0.491N	P=0.208	P=0.123N
Logistic regression test	P=0.293N	P=0.500N	P=0.189	P=0.249N
Cochran-Armitage test	P=0.345N			
Fisher exact test		P=0.500N	P=0.175	P=0.318N
<b>Liver: Hepatocellular Carcinoma</b>				
Overall rate	7/50 (14%)	11/50 (22%)	13/49 (27%)	7/50 (14%)
Adjusted rate	15.3%	24.6%	30.3%	15.0%
Terminal rate	1/32 (3%)	1/32 (3%)	4/32 (13%)	4/43 (9%)
First incidence (days)	437	571	342	532
Life table test	P=0.304N	P=0.255	P=0.139	P=0.475N
Logistic regression test	P=0.163	P=0.128	P=0.038	P=0.208
Cochran-Armitage test	P=0.478N			
Fisher exact test		P=0.218	P=0.096	P=0.613N



**TABLE C3**  
**Statistical Analysis of Primary Neoplasms in Male Mice in the 2-Year Inhalation Study of Acetonitrile (continued)**

	0 ppm	50 ppm	100 ppm	200 ppm
<b>Liver: Hepatocellular Adenoma or Carcinoma</b>				
Overall rate	19/50 (38%)	21/50 (42%)	30/49 (61%)	15/50 (30%)
Adjusted rate	44.5%	46.7%	67.7%	31.8%
Terminal rate	10/32 (31%)	9/32 (28%)	18/32 (56%)	11/43 (26%)
First incidence (days)	437	434	342	532
Life table test	P=0.070N	P=0.447	P=0.054	P=0.094N
Logistic regression test	P=0.437N	P=0.394	P=0.013	P=0.454N
Cochran-Armitage test	P=0.260N			
Fisher exact test		P=0.419	P=0.017	P=0.263N
<b>Lung: Alveolar/bronchiolar Adenoma</b>				
Overall rate	6/50 (12%)	9/50 (18%)	8/48 (17%)	18/50 (36%)
Adjusted rate	18.8%	28.1%	24.2%	38.2%
Terminal rate	6/32 (19%)	9/32 (28%)	7/32 (22%)	14/43 (33%)
First incidence (days)	733 (T)	733 (T)	727	554
Life table test	P=0.024	P=0.279	P=0.384	P=0.037
Logistic regression test	P=0.010	P=0.279	P=0.375	P=0.011
Cochran-Armitage test	P=0.002			
Fisher exact test		P=0.288	P=0.355	P=0.005
<b>Lung: Alveolar/bronchiolar Carcinoma</b>				
Overall rate	4/50 (8%)	6/50 (12%)	6/48 (13%)	4/50 (8%)
Adjusted rate	12.1%	16.5%	16.4%	9.3%
Terminal rate	3/32 (9%)	4/32 (13%)	3/32 (9%)	4/43 (9%)
First incidence (days)	729	583	607	733 (T)
Life table test	P=0.315N	P=0.377	P=0.375	P=0.477N
Logistic regression test	P=0.450N	P=0.374	P=0.367	P=0.491N
Cochran-Armitage test	P=0.503N			
Fisher exact test		P=0.370	P=0.344	P=0.643N
<b>Lung: Alveolar/bronchiolar Adenoma or Carcinoma</b>				
Overall rate	10/50 (20%)	14/50 (28%)	14/48 (29%)	21/50 (42%)
Adjusted rate	30.3%	40.3%	38.5%	44.6%
Terminal rate	9/32 (28%)	12/32 (38%)	10/32 (31%)	17/43 (40%)
First incidence (days)	729	583	607	554
Life table test	P=0.119	P=0.239	P=0.245	P=0.113
Logistic regression test	P=0.038	P=0.239	P=0.234	P=0.042
Cochran-Armitage test	P=0.011			
Fisher exact test		P=0.241	P=0.206	P=0.015
<b>All Organs: Hemangiosarcoma</b>				
Overall rate	2/50 (4%)	4/50 (8%)	1/50 (2%)	5/50 (10%)
Adjusted rate	5.9%	11.3%	2.9%	10.7%
Terminal rate	0/32 (0%)	3/32 (9%)	0/32 (0%)	2/43 (5%)
First incidence (days)	716	583	720	554
Life table test	P=0.339	P=0.338	P=0.500N	P=0.331
Logistic regression test	P=0.208	P=0.340	P=0.499N	P=0.189
Cochran-Armitage test	P=0.210			
Fisher exact test		P=0.339	P=0.500N	P=0.218

**TABLE C3**  
**Statistical Analysis of Primary Neoplasms in Male Mice in the 2-Year Inhalation Study of Acetonitrile (continued)**

	0 ppm	50 ppm	100 ppm	200 ppm
<b>All Organs: Hemangioma or Hemangiosarcoma</b>				
Overall rate	3/50 (6%)	6/50 (12%)	2/50 (4%)	7/50 (14%)
Adjusted rate	8.8%	17.4%	6.0%	15.1%
Terminal rate	1/32 (3%)	5/32 (16%)	1/32 (3%)	4/43 (9%)
First incidence (days)	716	583	720	554
Life table test	P=0.340	P=0.245	P=0.500N	P=0.290
Logistic regression test	P=0.216	P=0.246	P=0.454N	P=0.165
Cochran-Armitage test	P=0.179			
Fisher exact test		P=0.243	P=0.500N	P=0.159
<b>All Organs: Malignant Lymphoma (Lymphocytic or Mixed)</b>				
Overall rate	3/50 (6%)	3/50 (6%)	4/50 (8%)	2/50 (4%)
Adjusted rate	8.9%	8.7%	10.6%	4.7%
Terminal rate	2/32 (6%)	1/32 (3%)	1/32 (3%)	2/43 (5%)
First incidence (days)	714	700	644	733 (T)
Life table test	P=0.292N	P=0.653	P=0.504	P=0.374N
Logistic regression test	P=0.373N	P=0.661N	P=0.504	P=0.401N
Cochran-Armitage test	P=0.420N			
Fisher exact test		P=0.661N	P=0.500	P=0.500N
<b>All Organs: Benign Neoplasms</b>				
Overall rate	25/50 (50%)	26/50 (52%)	26/50 (52%)	28/50 (56%)
Adjusted rate	63.1%	67.6%	67.8%	59.5%
Terminal rate	18/32 (56%)	20/32 (63%)	20/32 (63%)	24/43 (56%)
First incidence (days)	437	434	537	554
Life table test	P=0.207N	P=0.505	P=0.506	P=0.291N
Logistic regression test	P=0.432	P=0.497	P=0.514	P=0.389
Cochran-Armitage test	P=0.308			
Fisher exact test		P=0.500	P=0.500	P=0.344
<b>All Organs: Malignant Neoplasms</b>				
Overall rate	20/50 (40%)	24/50 (48%)	19/50 (38%)	18/50 (36%)
Adjusted rate	46.2%	53.7%	43.4%	37.4%
Terminal rate	10/32 (31%)	12/32 (38%)	8/32 (25%)	13/43 (30%)
First incidence (days)	437	571	342	532
Life table test	P=0.076N	P=0.319	P=0.486N	P=0.164N
Logistic regression test	P=0.427N	P=0.257	P=0.526N	P=0.491
Cochran-Armitage test	P=0.255N			
Fisher exact test		P=0.273	P=0.500N	P=0.418N

**TABLE C3**  
**Statistical Analysis of Primary Neoplasms in Male Mice in the 2-Year Inhalation Study of Acetonitrile** (continued)

	0 ppm	50 ppm	100 ppm	200 ppm
<b>All Organs: Benign or Malignant Neoplasms</b>				
Overall rate	34/50 (68%)	38/50 (76%)	38/50 (76%)	35/50 (70%)
Adjusted rate	76.7%	82.3%	80.7%	71.4%
Terminal rate	22/32 (69%)	24/32 (75%)	23/32 (72%)	29/43 (67%)
First incidence (days)	437	434	342	532
Life table test	P=0.061N	P=0.326	P=0.335	P=0.123N
Logistic regression test	P=0.482	P=0.251	P=0.247	P=0.414
Cochran-Armitage test	P=0.532			
Fisher exact test		P=0.252	P=0.252	P=0.500

(T)Terminal sacrifice

- <sup>a</sup> Number of neoplasm-bearing animals/number of animals examined. Denominator is number of animals examined microscopically for adrenal gland, liver, and lung; for other tissues, denominator is number of animals necropsied.
- <sup>b</sup> Kaplan-Meier estimated neoplasm incidence at the end of the study after adjustment for intercurrent mortality
- <sup>c</sup> Observed incidence at terminal kill
- <sup>d</sup> Beneath the control incidence are the P values associated with the trend test. Beneath the exposed group incidence are the P values corresponding to pairwise comparisons between the controls and that exposed group. The life table test regards neoplasms in animals dying prior to terminal kill as being (directly or indirectly) the cause of death. The logistic regression test regards these lesions as nonfatal. The Cochran-Armitage and Fisher exact tests compare directly the overall incidence rates. For all tests, a negative trend or a lower incidence in an exposure group is indicated by N.
- <sup>e</sup> Not applicable; no neoplasms in animal group

**TABLE C4a**  
**Historical Incidence of Alveolar/bronchiolar Neoplasms in Untreated Male B6C3F<sub>1</sub> Mice<sup>a</sup>**

Study	Incidence in Controls		
	Adenoma	Carcinoma	Adenoma or Carcinoma
<b>Historical Incidence at Battelle Pacific Northwest Laboratories</b>			
1,3-Butadiene	18/50	5/50	21/50
Allyl Glycidyl Ether	7/50	0/50	7/50
2-Chloroacetophenone	7/50	6/50	11/50
<i>l</i> -Epinephrine Hydrochloride	11/50	5/50	15/50
Chloroethane	3/50	2/50	5/50
Hexachlorocyclopentadiene	11/49	0/49	11/49
<i>o</i> -Chlorobenzalmalononitrile (CS2)	7/49	7/49	14/49
<b>Overall Historical Incidence</b>			
Total	113/673 (16.8%)	45/673 (6.7%)	150/673 (22.3%)
Standard deviation	7.6%	5.6%	9.0%
Range	6%-36%	0%-16%	10%-42%

<sup>a</sup> Data as of 31 March 1993

**TABLE C4b**  
**Historical Incidence of Hepatocellular Neoplasms in Untreated Male B6C3F<sub>1</sub> Mice<sup>a</sup>**

Study	Incidence in Controls		
	Adenoma	Carcinoma	Adenoma or Carcinoma
<b>Historical Incidence at Battelle Pacific Northwest Laboratories</b>			
1,3-Butadiene	13/50	11/50	21/50
Allyl Glycidyl Ether	15/49	10/49	23/49
2-Chloroacetophenone	5/50	11/50	16/50
<i>l</i> -Epinephrine Hydrochloride	10/50	12/50	20/50
Chloroethane	6/50	9/50	15/50
Hexachlorocyclopentadiene	19/50	7/50	24/50
<i>o</i> -Chlorobenzalmalononitrile (CS2)	4/49	14/49	18/49
<b>Overall Historical Incidence</b>			
Total	120/673 (17.8%)	136/673 (20.2%)	241/673 (35.8%)
Standard deviation	11.0%	5.9%	12.1%
Range	4%-38%	9%-29%	11%-56%

<sup>a</sup> Data as of 31 March 1993

**TABLE C4c**  
**Historical Incidence of Forestomach Squamous Cell Papilloma in Untreated Male B6C3F<sub>1</sub> Mice<sup>a</sup>**

Study	Incidence in Controls
<b>Historical Incidence at Battelle Pacific Northwest Laboratories</b>	
1,3-Butadiene	1/50
Allyl Glycidyl Ether	1/50
2-Chloroacetophenone	2/50
<i>l</i> -Epinephrine Hydrochloride	0/50
Chloroethane	0/50
Hexachlorocyclopentadiene	0/50
<i>o</i> -Chlorobenzalmalononitrile (CS2)	0/50
<b>Overall Historical Incidence</b>	
Total	5/676 (0.7%)
Standard deviation	1.3%
Range	0%-4%

<sup>a</sup> Data as of 31 March 1993

**TABLE C5**  
**Summary of the Incidence of Nonneoplastic Lesions in Male Mice in the 2-Year Inhalation Study of Acetonitrile<sup>a</sup>**

	0 ppm	50 ppm	100 ppm	200 ppm
<b>Disposition Summary</b>				
Animals initially in study	60	60	60	60
<i>15-Month interim evaluation</i>	10	10	10	10
Early deaths				
Moribund	13	14	16	6
Natural deaths	5	4	2	1
Survivors				
Terminal sacrifice	32	32	32	43
Animals examined microscopically	60	60	60	60
<b>15-Month Interim Evaluation</b>				
<b>Alimentary System</b>				
Gallbladder	(9)	(10)	(9)	(10)
Inflammation, suppurative				1 (10%)
Liver	(10)	(10)	(10)	(10)
Angiectasis				1 (10%)
Basophilic focus			1 (10%)	
Degeneration, fatty	2 (20%)	5 (50%)	5 (50%)	2 (20%)
Eosinophilic focus		1 (10%)		
Mesentery		(1)		
Fat, necrosis		1 (100%)		
Stomach, forestomach	(10)	(10)	(10)	(10)
Hyperplasia, squamous		2 (20%)		3 (30%)
<b>Cardiovascular System</b>				
Heart	(10)	(10)	(10)	(10)
Angiectasis				1 (10%)
Cardiomyopathy		1 (10%)		
<b>Endocrine System</b>				
Adrenal cortex	(10)	(10)	(10)	(10)
Hyperplasia		2 (20%)	4 (40%)	3 (30%)
Hypertrophy	3 (30%)	6 (60%)	4 (40%)	4 (40%)
Islets, pancreatic	(10)	(10)	(10)	(10)
Hyperplasia	2 (20%)	1 (10%)	1 (10%)	
Pituitary gland	(10)	(10)	(10)	(10)
Pars distalis, cyst		1 (10%)		2 (20%)
<b>Genital System</b>				
Epididymis	(10)	(10)	(10)	(10)
Granuloma sperm				1 (10%)
Preputial gland	(10)	(10)	(10)	(10)
Inflammation, chronic active	1 (10%)		2 (20%)	3 (30%)

<sup>a</sup> Number of animals examined microscopically at the site and the number of animals with lesion

TABLE C5

Summary of the Incidence of Nonneoplastic Lesions in Male Mice in the 2-Year Inhalation Study of Acetonitrile  
(continued)

	0 ppm	50 ppm	100 ppm	200 ppm
<b>15-Month Interim Evaluation</b> (continued)				
<b>Hematopoietic System</b>				
Lymph node, mesenteric	(8)	(10)	(10)	(9)
Congestion		1 (10%)		
Hyperplasia	2 (25%)			
<b>Integumentary System</b>				
Skin	(10)	(10)	(10)	(10)
Subcutaneous tissue, inflammation, chronic	1 (10%)	1 (10%)		
<b>Musculoskeletal System</b>				
Bone	(10)	(10)	(10)	(10)
Inflammation, suppurative	1 (10%)			
<b>Nervous System</b>				
Brain	(10)	(10)	(10)	(10)
Mineralization	3 (30%)	5 (50%)	3 (30%)	2 (20%)
<b>Respiratory System</b>				
Larynx	(10)	(10)	(10)	(10)
Inflammation, suppurative	1 (10%)			
Lung	(10)	(10)	(10)	(10)
Hemorrhage		1 (10%)	1 (10%)	
Alveolar epithelium, hyperplasia				2 (20%)
Perivascular, infiltration cellular, mononuclear cell				1 (10%)
<b>Urinary System</b>				
Kidney	(10)	(10)	(10)	(10)
Hydronephrosis			2 (20%)	
Nephropathy	4 (40%)	2 (20%)	4 (40%)	1 (10%)
Renal tubule, hyperplasia			1 (10%)	
<b>Systems Examined With No Lesions Observed</b>				
General Body System				
Special Senses System				

TABLE C5

Summary of the Incidence of Nonneoplastic Lesions in Male Mice in the 2-Year Inhalation Study of Acetonitrile  
(continued)

	0 ppm	50 ppm	100 ppm	200 ppm
<b>2-Year Study</b>				
<b>Alimentary System</b>				
Gallbladder	(45)	(46)	(46)	(45)
Cyst		1 (2%)		
Degeneration	2 (4%)	1 (2%)	1 (2%)	
Hyperplasia	1 (2%)			
Inflammation, suppurative		3 (7%)	1 (2%)	2 (4%)
Intestine large, cecum	(47)	(49)	(48)	(48)
Necrosis	1 (2%)			
Intestine small, duodenum	(47)	(48)	(48)	(48)
Peyer's patch, hyperplasia			1 (2%)	
Intestine small, jejunum	(45)	(48)	(47)	(49)
Peyer's patch, hyperplasia	1 (2%)	1 (2%)	1 (2%)	1 (2%)
Intestine small, ileum	(46)	(49)	(48)	(49)
Peyer's patch, hyperplasia		1 (2%)		1 (2%)
Liver	(50)	(50)	(49)	(50)
Angiectasis		1 (2%)	1 (2%)	
Basophilic focus	1 (2%)	2 (4%)	4 (8%)	1 (2%)
Clear cell focus	4 (8%)	1 (2%)	2 (4%)	3 (6%)
Cytomegaly	1 (2%)			
Degeneration, fatty	3 (6%)	4 (8%)	7 (14%)	2 (4%)
Eosinophilic focus	5 (10%)	4 (8%)	5 (10%)	4 (8%)
Focal cellular change	1 (2%)			1 (2%)
Hematopoietic cell proliferation	2 (4%)	3 (6%)	4 (8%)	2 (4%)
Hemorrhage	1 (2%)	1 (2%)		
Infarct	2 (4%)	2 (4%)	2 (4%)	1 (2%)
Karyomegaly	4 (8%)	3 (6%)	2 (4%)	3 (6%)
Mitotic alteration	1 (2%)	3 (6%)		
Mixed cell focus	2 (4%)	6 (12%)	3 (6%)	3 (6%)
Necrosis	5 (10%)	4 (8%)	1 (2%)	1 (2%)
Vacuolization cytoplasmic			1 (2%)	
Bile duct, cyst		3 (6%)		1 (2%)
Bile duct, degeneration	1 (2%)			
Bile duct, hyperplasia	1 (2%)			
Centrilobular, necrosis	2 (4%)	2 (4%)		
Kupffer cell, pigmentation			1 (2%)	
Mesentery	(3)	(2)	(3)	(3)
Angiectasis		1 (50%)		
Inflammation, chronic		1 (50%)		
Fat, necrosis	2 (67%)		2 (67%)	2 (67%)
Pancreas	(49)	(50)	(48)	(50)
Atrophy	1 (2%)	1 (2%)	3 (6%)	
Focal cellular change	3 (6%)	2 (4%)		1 (2%)
Inflammation, chronic			2 (4%)	
Duct, ectasia			1 (2%)	
Salivary glands	(50)	(50)	(48)	(50)
Cyst				1 (2%)
Inflammation, chronic		1 (2%)		
Inflammation, suppurative		1 (2%)		



TABLE C5

Summary of the Incidence of Nonneoplastic Lesions in Male Mice in the 2-Year Inhalation Study of Acetonitrile  
(continued)

	0 ppm	50 ppm	100 ppm	200 ppm
<b>2-Year Study</b> (continued)				
<b>Alimentary System</b> (continued)				
Stomach, forestomach	(49)	(50)	(48)	(50)
Hyperkeratosis	1 (2%)		3 (6%)	2 (4%)
Hyperplasia, squamous	3 (6%)	3 (6%)	6 (13%)	12 (24%)
Inflammation, suppurative	2 (4%)	1 (2%)	4 (8%)	2 (4%)
Ulcer	1 (2%)	1 (2%)	1 (2%)	2 (4%)
Stomach, glandular	(49)	(50)	(48)	(50)
Degeneration			1 (2%)	1 (2%)
Ectopic tissue				1 (2%)
Erosion	2 (4%)			1 (2%)
Hyperplasia			1 (2%)	2 (4%)
Inflammation, suppurative	1 (2%)		1 (2%)	
Pigmentation, hemosiderin	2 (4%)	1 (2%)		1 (2%)
Tooth	(3)			(1)
Dysplasia	2 (67%)			
Inflammation	1 (33%)			1 (100%)
<b>Cardiovascular System</b>				
Heart	(50)	(50)	(49)	(50)
Cardiomyopathy	40 (80%)	41 (82%)	46 (94%)	44 (88%)
Necrosis	1 (2%)			1 (2%)
Arteriole, inflammation, chronic	2 (4%)			
<b>Endocrine System</b>				
Adrenal cortex	(48)	(50)	(48)	(50)
Accessory adrenal cortical nodule		1 (2%)	1 (2%)	1 (2%)
Cyst		1 (2%)	1 (2%)	
Hyperplasia	7 (15%)	9 (18%)	9 (19%)	9 (18%)
Hypertrophy	25 (52%)	30 (60%)	19 (40%)	33 (66%)
Capsule, hyperplasia	1 (2%)			
Adrenal medulla	(49)	(50)	(47)	(50)
Hyperplasia	2 (4%)		1 (2%)	1 (2%)
Islets, pancreatic	(47)	(50)	(48)	(50)
Hyperplasia	4 (9%)	6 (12%)	8 (17%)	4 (8%)
Parathyroid gland	(39)	(36)	(40)	(27)
Hyperplasia	1 (3%)			
Pituitary gland	(46)	(48)	(46)	(49)
Pars distalis, cyst	4 (9%)	1 (2%)	1 (2%)	1 (2%)
Pars distalis, hyperplasia	1 (2%)	3 (6%)	2 (4%)	
Thyroid gland	(49)	(50)	(48)	(50)
Follicle, cyst		1 (2%)	2 (4%)	
Follicular cell, hyperplasia	7 (14%)	5 (10%)	2 (4%)	1 (2%)
<b>General Body System</b>				
None				

**TABLE C5**  
**Summary of the Incidence of Nonneoplastic Lesions in Male Mice in the 2-Year Inhalation Study of Acetonitrile**  
 (continued)

	0 ppm	50 ppm	100 ppm	200 ppm
<b>2-Year Study (continued)</b>				
<b>Genital System</b>				
Epididymis	(50)	(50)	(48)	(50)
Granuloma sperm			1 (2%)	1 (2%)
Hyperplasia			1 (2%)	
Inflammation, chronic active				1 (2%)
Inflammation, suppurative				1 (2%)
Preputial gland	(49)	(50)	(46)	(50)
Atrophy	2 (4%)			1 (2%)
Ectasia	4 (8%)	12 (24%)	4 (9%)	2 (4%)
Inflammation, chronic active	13 (27%)	16 (32%)	7 (15%)	17 (34%)
Prostate	(45)	(45)	(42)	(45)
Inflammation, suppurative	1 (2%)	1 (2%)	1 (2%)	2 (4%)
Seminal vesicle	(49)	(50)	(47)	(50)
Inflammation, chronic active	1 (2%)	1 (2%)	1 (2%)	
Inflammation, suppurative		1 (2%)		1 (2%)
Testes	(50)	(50)	(49)	(50)
Atrophy	3 (6%)	1 (2%)	1 (2%)	2 (4%)
Mineralization		1 (2%)		
Interstitial cell, hyperplasia			1 (2%)	
<b>Hematopoietic System</b>				
Bone marrow	(49)	(50)	(48)	(50)
Angiectasis	1 (2%)			1 (2%)
Fibrosis	2 (4%)			
Hyperplasia, megakaryocyte		1 (2%)		
Hyperplasia, neutrophil	5 (10%)	7 (14%)	9 (19%)	11 (22%)
Thrombosis	1 (2%)			
Lymph node	(3)	(2)	(2)	
Iliac, hyperplasia		1 (50%)		
Pancreatic, hyperplasia			1 (50%)	
Renal, hyperplasia			1 (50%)	
Lymph node, bronchial	(38)	(37)	(38)	(41)
Hyperplasia	1 (3%)	2 (5%)		
Lymph node, mandibular	(35)	(33)	(29)	(36)
Hyperplasia	2 (6%)	3 (9%)	1 (3%)	2 (6%)
Lymph node, mesenteric	(48)	(49)	(47)	(49)
Angiectasis	1 (2%)			
Congestion		1 (2%)	5 (11%)	1 (2%)
Hematopoietic cell proliferation	2 (4%)		3 (6%)	
Hyperplasia	3 (6%)	10 (20%)	8 (17%)	3 (6%)
Lymph node, mediastinal	(42)	(38)	(35)	(33)
Hyperplasia	2 (5%)	2 (5%)	1 (3%)	
Spleen	(49)	(50)	(48)	(50)
Amyloid deposition	1 (2%)			
Angiectasis				1 (2%)
Hematopoietic cell proliferation	12 (24%)	15 (30%)	16 (33%)	13 (26%)
Hyperplasia, lymphoid	4 (8%)	2 (4%)	4 (8%)	8 (16%)
Hyperplasia, mononuclear cell				1 (2%)

TABLE C5

Summary of the Incidence of Nonneoplastic Lesions in Male Mice in the 2-Year Inhalation Study of Acetonitrile  
(continued)

	0 ppm	50 ppm	100 ppm	200 ppm
<b>2-Year Study</b> (continued)				
<b>Hematopoietic System</b> (continued)				
Thymus	(44)	(45)	(38)	(47)
Atrophy	4 (9%)	2 (4%)	1 (3%)	1 (2%)
Hyperplasia, lymphoid	1 (2%)	1 (2%)		
Necrosis	1 (2%)			
Epithelial cell, hyperplasia		1 (2%)	1 (3%)	1 (2%)
<b>Integumentary System</b>				
Skin	(50)	(49)	(49)	(50)
Cyst epithelial inclusion				1 (2%)
Inflammation, suppurative	1 (2%)			2 (4%)
Pinna, granuloma	1 (2%)			
Subcutaneous tissue, inflammation, chronic	5 (10%)	7 (14%)	10 (20%)	10 (20%)
<b>Musculoskeletal System</b>				
Bone	(50)	(50)	(49)	(50)
Fibrous osteodystrophy			1 (2%)	
<b>Nervous System</b>				
Brain	(50)	(50)	(48)	(50)
Mineralization	20 (40%)	21 (42%)	13 (27%)	18 (36%)
Thrombosis	1 (2%)			
<b>Respiratory System</b>				
Lung	(50)	(50)	(48)	(50)
Hemorrhage	5 (10%)	3 (6%)		1 (2%)
Inflammation, chronic, focal				1 (2%)
Inflammation, granulomatous				1 (2%)
Alveolar epithelium, hyperplasia	4 (8%)	5 (10%)	3 (6%)	2 (4%)
Nose	(50)	(50)	(48)	(50)
Exudate	1 (2%)			
Inflammation, suppurative	3 (6%)	2 (4%)	3 (6%)	2 (4%)
Nasolacrimal duct, inflammation, suppurative	4 (8%)	2 (4%)		
Olfactory epithelium, atrophy	4 (8%)	1 (2%)	2 (4%)	1 (2%)
Olfactory epithelium, metaplasia	3 (6%)	1 (2%)	2 (4%)	1 (2%)
Respiratory epithelium, hyperplasia				1 (2%)
Respiratory epithelium, metaplasia, squamous	1 (2%)			
Trachea	(49)	(50)	(48)	(50)
Metaplasia, squamous			1 (2%)	
<b>Special Senses System</b>				
None				

TABLE C5

**Summary of the Incidence of Nonneoplastic Lesions in Male Mice in the 2-Year Inhalation Study of Acetonitrile**  
(continued)

	0 ppm	50 ppm	100 ppm	200 ppm
<b>2-Year Study</b> (continued)				
<b>Urinary System</b>				
Kidney	(49)	(50)	(48)	(50)
Amyloid deposition	1 (2%)			
Hydronephrosis	3 (6%)	5 (10%)	2 (4%)	6 (12%)
Hyperplasia, cystic	2 (4%)	1 (2%)		2 (4%)
Inflammation, suppurative	1 (2%)	3 (6%)	3 (6%)	2 (4%)
Metaplasia, osseous		1 (2%)	1 (2%)	
Nephropathy	37 (76%)	39 (78%)	35 (73%)	42 (84%)
Arteriole, inflammation, chronic	1 (2%)			
Cortex, cyst	5 (10%)	2 (4%)	3 (6%)	1 (2%)
Renal tubule, mineralization	1 (2%)			
Urinary bladder	(49)	(49)	(49)	(50)
Dilatation		2 (4%)	2 (4%)	3 (6%)
Hemorrhage		1 (2%)		
Inflammation, chronic	1 (2%)	1 (2%)	3 (6%)	1 (2%)
Inflammation, suppurative		2 (4%)		1 (2%)
Pigmentation, melanin		1 (2%)		
Ulcer		1 (2%)	1 (2%)	1 (2%)
Transitional epithelium, hyperplasia		2 (4%)	1 (2%)	2 (4%)

**APPENDIX D**  
**SUMMARY OF LESIONS IN FEMALE MICE**  
**IN THE 2-YEAR INHALATION STUDY**  
**OF ACETONITRILE**

<b>TABLE D1</b>	<b>Summary of the Incidence of Neoplasms in Female Mice in the 2-Year Inhalation Study of Acetonitrile .....</b>	<b>179</b>
<b>TABLE D2</b>	<b>Individual Animal Tumor Pathology of Female Mice in the 2-Year Inhalation Study of Acetonitrile .....</b>	<b>184</b>
<b>TABLE D3</b>	<b>Statistical Analysis of Primary Neoplasms in Female Mice in the 2-Year Inhalation Study of Acetonitrile .....</b>	<b>204</b>
<b>TABLE D4a</b>	<b>Historical Incidence of Alveolar/bronchiolar Neoplasms in Untreated Female B6C3F<sub>1</sub> Mice .....</b>	<b>209</b>
<b>TABLE D4b</b>	<b>Historical Incidence of Hepatocellular Neoplasms in Untreated Female B6C3F<sub>1</sub> Mice .....</b>	<b>209</b>
<b>TABLE D4c</b>	<b>Historical Incidence of Forestomach Squamous Cell Papilloma in Untreated Female B6C3F<sub>1</sub> Mice .....</b>	<b>210</b>
<b>TABLE D5</b>	<b>Summary of the Incidence of Nonneoplastic Lesions in Female Mice in the 2-Year Inhalation Study of Acetonitrile .....</b>	<b>211</b>



**TABLE D1**  
**Summary of the Incidence of Neoplasms in Female Mice in the 2-Year Inhalation Study of Acetonitrile<sup>a</sup>**

	0 ppm	50 ppm	100 ppm	200 ppm
<b>Disposition Summary</b>				
Animals initially in study	60	60	60	60
<b>15-Month interim evaluation</b>				
Early deaths	10	10	10	10
Accidental death	1			
Moribund	15	12	13	13
Natural deaths	6	5	8	5
Survivors				
Died last week of study		1		
Terminal sacrifice	28	32	29	32
Animals examined microscopically	60	60	60	60
<b>15-Month Interim Evaluation</b>				
<b>Alimentary System</b>				
Liver	(10)	(10)	(10)	(10)
Hepatocellular adenoma		2 (20%)	1 (10%)	
Mesentery	(2)		(1)	
Salivary glands	(10)	(10)	(10)	(10)
<b>Respiratory System</b>				
Lung	(10)	(10)	(10)	(10)
Alveolar/bronchiolar adenoma			2 (20%)	1 (10%)
<b>Systemic Lesions</b>				
Multiple organs <sup>b</sup>	(10)	(10)	(10)	(10)
Lymphoma malignant lymphocytic	1 (10%)			
<b>Systems Examined With No Neoplasms Observed</b>				
Cardiovascular System				
Endocrine System				
General Body System				
Genital System				
Hematopoietic System				
Integumentary System				
Musculoskeletal System				
Nervous System				
Special Senses System				
Urinary System				
<b>2-Year Study</b>				
<b>Alimentary System</b>				
Gallbladder	(42)	(45)	(41)	(46)
Intestine large, cecum	(45)	(46)	(48)	(46)
Leiomyosarcoma				1 (2%)
Intestine small, duodenum	(42)	(44)	(44)	(45)

TABLE D1

Summary of the Incidence of Neoplasms in Female Mice in the 2-Year Inhalation Study of Acetonitrile (continued)

	0 ppm	50 ppm	100 ppm	200 ppm
<b>2-Year Study</b> (continued)				
<b>Alimentary System</b> (continued)				
Intestine small, jejunum	(44)	(46)	(46)	(47)
Intestine small, ileum	(45)	(47)	(45)	(47)
Liver	(49)	(50)	(50)	(49)
Hemangiosarcoma				1 (2%)
Hemangiosarcoma, multiple			1 (2%)	
Hepatocellular carcinoma	5 (10%)	5 (10%)	4 (8%)	4 (8%)
Hepatocellular carcinoma, multiple	2 (4%)	1 (2%)	2 (4%)	1 (2%)
Hepatocellular adenoma	3 (6%)	7 (14%)	6 (12%)	4 (8%)
Hepatocellular adenoma, multiple	1 (2%)	1 (2%)	2 (4%)	2 (4%)
Histiocytic sarcoma	2 (4%)		1 (2%)	1 (2%)
Mesentery	(8)	(16)	(6)	(5)
Carcinoma, metastatic, ovary		1 (6%)		
Sarcoma stromal, metastatic, uterus		1 (6%)		
Fat, carcinoma, metastatic, pancreas			1 (17%)	
Fat, hemangioma		1 (6%)		
Fat, histiocytic sarcoma		1 (6%)		
Pancreas	(49)	(49)	(50)	(48)
Adenocarcinoma			1 (2%)	
Fibrosarcoma			1 (2%)	
Sarcoma stromal, metastatic, uterus		1 (2%)		
Salivary glands	(49)	(50)	(50)	(49)
Stomach, forestomach	(49)	(50)	(50)	(48)
Carcinoma, metastatic, pancreas			1 (2%)	
Sarcoma stromal, metastatic, uterus		1 (2%)		
Squamous cell papilloma	1 (2%)		1 (2%)	3 (6%)
Stomach, glandular	(49)	(48)	(50)	(48)
Carcinoma, metastatic, pancreas			1 (2%)	
Sarcoma stromal, metastatic, uterus		1 (2%)		
<b>Cardiovascular System</b>				
Heart	(49)	(50)	(49)	(50)
Histiocytic sarcoma	1 (2%)			
<b>Endocrine System</b>				
Adrenal cortex	(49)	(49)	(50)	(49)
Histiocytic sarcoma	1 (2%)			
Capsule, adenoma		1 (2%)		
Adrenal medulla	(48)	(48)	(50)	(49)
Histiocytic sarcoma	1 (2%)			
Pheochromocytoma malignant	1 (2%)			
Pheochromocytoma benign	2 (4%)			
Islets, pancreatic	(49)	(49)	(50)	(48)
Adenoma			2 (4%)	
Pituitary gland	(48)	(49)	(50)	(48)
Pars distalis, adenoma	14 (29%)	14 (29%)	15 (30%)	6 (13%)
Pars intermedia, adenoma				2 (4%)
Thyroid gland	(49)	(48)	(50)	(49)
Bilateral, follicular cell, adenoma			1 (2%)	
Follicular cell, adenoma	2 (4%)	3 (6%)	1 (2%)	1 (2%)



**TABLE D1**  
**Summary of the Incidence of Neoplasms in Female Mice in the 2-Year Inhalation Study of Acetonitrile (continued)**

	0 ppm	50 ppm	100 ppm	200 ppm
<b>2-Year Study (continued)</b>				
<b>General Body System</b>				
Tissue NOS	(2)		(1)	
Sarcoma	1 (50%)			
<b>Genital System</b>				
Ovary	(48)	(47)	(48)	(48)
Arrhenoblastoma NOS	1 (2%)			
Cystadenoma	1 (2%)	2 (4%)	1 (2%)	1 (2%)
Hemangioma	1 (2%)			
Histiocytic sarcoma	1 (2%)			
Luteoma	1 (2%)			
Sarcoma stromal, metastatic, uterus		1 (2%)		
Yolk sac carcinoma		1 (2%)		
Uterus	(49)	(49)	(50)	(49)
Hemangioma	1 (2%)	1 (2%)		
Hemangiosarcoma	2 (4%)			
Leiomyoma		1 (2%)		
Leiomyosarcoma		1 (2%)		
Polyp stromal	2 (4%)	2 (4%)	3 (6%)	3 (6%)
Sarcoma stromal		1 (2%)		
Cervix, fibroma				1 (2%)
<b>Hematopoietic System</b>				
Bone marrow	(49)	(49)	(50)	(49)
Hemangiosarcoma	1 (2%)			
Histiocytic sarcoma	2 (4%)		1 (2%)	
Osteosarcoma, metastatic, bone				1 (2%)
Lymph node	(7)	(9)	(9)	(1)
Pancreatic, histiocytic sarcoma	1 (14%)			
Renal, histiocytic sarcoma	1 (14%)			
Lymph node, bronchial	(38)	(44)	(42)	(36)
Carcinoma, metastatic, pancreas			1 (2%)	
Histiocytic sarcoma	2 (5%)			
Lymph node, mandibular	(35)	(39)	(44)	(33)
Histiocytic sarcoma	1 (3%)			
Lymph node, mesenteric	(44)	(44)	(47)	(43)
Carcinoma, metastatic, pancreas			1 (2%)	
Histiocytic sarcoma	2 (5%)	1 (2%)		
Sarcoma stromal, metastatic, uterus		1 (2%)		
Lymph node, mediastinal	(36)	(35)	(40)	(34)
Histiocytic sarcoma	2 (6%)			
Sarcoma stromal, metastatic, uterus		1 (3%)		
Spleen	(49)	(49)	(50)	(48)
Hemangiosarcoma	2 (4%)			1 (2%)
Histiocytic sarcoma	2 (4%)		1 (2%)	
Thymus	(44)	(48)	(46)	(41)
Sarcoma stromal, metastatic		1 (2%)		

**TABLE D1**  
**Summary of the Incidence of Neoplasms in Female Mice in the 2-Year Inhalation Study of Acetonitrile** (continued)

	0 ppm	50 ppm	100 ppm	200 ppm
<b>2-Year Study</b> (continued)				
<b>Integumentary System</b>				
Mammary gland	(49)	(47)	(50)	(48)
Adenoacanthoma			1 (2%)	
Adenocarcinoma	3 (6%)		3 (6%)	1 (2%)
Skin	(49)	(50)	(50)	(49)
Subcutaneous tissue, hemangiosarcoma				1 (2%)
Subcutaneous tissue, sarcoma			2 (4%)	
Subcutaneous tissue, sarcoma stromal, metastatic, uterus		1 (2%)		
<b>Musculoskeletal System</b>				
Bone	(49)	(50)	(50)	(50)
Osteosarcoma				1 (2%)
<b>Nervous System</b>				
Brain	(49)	(50)	(50)	(49)
<b>Respiratory System</b>				
Lung	(49)	(50)	(50)	(49)
Adenocarcinoma, metastatic, harderian gland			1 (2%)	1 (2%)
Adenocarcinoma, metastatic, mammary gland	1 (2%)			
Alveolar/bronchiolar adenoma	6 (12%)	2 (4%)	2 (4%)	
Alveolar/bronchiolar adenoma, multiple	1 (2%)			
Alveolar/bronchiolar carcinoma	1 (2%)			1 (2%)
Alveolar/bronchiolar carcinoma, multiple		1 (2%)		
Carcinoma, metastatic, pancreas			1 (2%)	
Hepatocellular carcinoma, metastatic, liver	1 (2%)	1 (2%)	2 (4%)	1 (2%)
Histiocytic sarcoma	2 (4%)			1 (2%)
Osteosarcoma, metastatic, bone				1 (2%)
Pheochromocytoma malignant, metastatic, adrenal medulla	1 (2%)			
Sarcoma stromal, metastatic, uterus		1 (2%)		
Nose	(49)	(50)	(50)	(49)
<b>Special Senses System</b>				
Harderian gland	(3)	(1)	(2)	(1)
Adenocarcinoma			1 (50%)	1 (100%)
Adenoma	3 (100%)	1 (100%)	1 (50%)	
<b>Urinary System</b>				
Kidney	(49)	(49)	(50)	(48)
Histiocytic sarcoma	2 (4%)			
Renal tubule, adenoma	1 (2%)			
Renal tubule, carcinoma	1 (2%)			
Urinary bladder	(48)	(48)	(50)	(47)

**TABLE D1**  
**Summary of the Incidence of Neoplasms in Female Mice in the 2-Year Inhalation Study of Acetonitrile** (continued)

	0 ppm	50 ppm	100 ppm	200 ppm
<b>2-Year Study</b> (continued)				
<b>Systemic Lesions</b>				
Multiple organs	(50)	(50)	(50)	(50)
Histiocytic sarcoma	2 (4%)	1 (2%)	1 (2%)	1 (2%)
Lymphoma malignant	1 (2%)			
Lymphoma malignant lymphocytic	5 (10%)	10 (20%)	9 (18%)	3 (6%)
Lymphoma malignant mixed	5 (10%)	7 (14%)	7 (14%)	11 (22%)
<b>Neoplasm Summary</b>				
Total animals with primary neoplasms <sup>c</sup>				
15-Month interim evaluation	1	2	3	1
2-Year study	35	36	37	32
Total primary neoplasms				
15-Month interim evaluation	1	2	3	1
2-Year study	73	64	68	51
Total animals with benign neoplasms				
15-Month interim evaluation		2	3	1
2-Year study	29	25	24	18
Total benign neoplasms				
15-Month interim evaluation		2	3	1
2-Year study	40	36	35	23
Total animals with malignant neoplasms				
15-Month interim evaluation	1			
2-Year study	23	23	27	24
Total malignant neoplasms				
15-Month interim evaluation	1			
2-Year study	32	28	33	28
Total animals with metastatic neoplasms				
2-Year study	3	3	3	3
Total metastatic neoplasms				
2-Year study	3	12	9	4
Total animals with uncertain neoplasms- benign or malignant				
2-Year study	1			
Total uncertain neoplasms				
2-Year study	1			

<sup>a</sup> Number of animals examined microscopically at the site and the number of animals with neoplasm

<sup>b</sup> Number of animals with any tissue examined microscopically

<sup>c</sup> Primary neoplasms: all neoplasms except metastatic neoplasms

**TABLE D2**  
**Individual Animal Tumor Pathology of Female Mice in the 2-Year Inhalation Study of Acetonitrile: 0 ppm**

Number of Days on Study	0	4	4	5	5	5	6	6	6	6	6	6	6	6	6	6	6	7	7	7	7	7	7	7	7	7	
Carcass ID Number	1	0	1	0	0	1	0	1	1	0	0	0	1	0	0	0	1	1	0	1	0	0	0	0	0	0	
	0	2	2	1	6	8	2	2	3	4	5	6	7	8	8	9	9	0	0	0	1	2	3	3	3		
	5	6	6	7	9	1	2	3	5	1	8	4	8	1	1	4	9	0	6	6	0	0	5	5	5		
	1	0	1	0	0	1	0	1	1	0	0	0	1	0	0	0	1	1	0	1	0	0	0	0	0		
	1	6	1	9	8	0	8	1	0	9	9	6	0	6	9	7	0	0	8	2	9	8	6	6	6		
	0	3	7	2	5	7	0	1	3	7	6	9	6	1	4	0	8	9	9	0	0	1	2	5	6		
<b>Alimentary System</b>																											
Esophagus	+	+	+	+	+	+	+	+	+	+	+	+	+	+	+	+	+	+	+	+	+	+	+	+	+	+	
Gallbladder	+	+	+	A	+	A	A	+	+	A	+	+	A	+	+	+	+	+	+	+	+	+	+	+	+	+	
Intestine large, colon	+	+	+	+	+	+	+	+	+	A	+	+	+	+	+	A	+	+	+	M	+	+	+	+	+	+	
Intestine large, rectum	+	+	+	+	+	+	+	+	+	+	+	+	+	+	+	+	+	M	+	+	+	+	+	+	+	+	
Intestine large, cecum	+	+	+	+	+	A	M	+	+	A	+	+	A	+	+	+	+	+	+	+	+	+	+	+	+	+	
Intestine small, duodenum	+	+	+	A	+	A	+	+	+	A	+	+	A	M	A	+	+	+	+	+	+	+	+	+	+	M	
Intestine small, jejunum	+	+	+	A	+	+	A	+	+	A	+	+	A	+	+	A	+	+	+	+	+	+	+	+	+	+	
Intestine small, ileum	+	+	+	+	+	A	+	+	+	A	+	+	A	+	+	A	+	+	+	+	+	+	+	+	+	+	
Liver	+	+	+	+	+	+	+	+	+	+	+	+	+	+	+	+	+	+	+	+	+	+	+	+	+	+	
Hepatocellular carcinoma																								X	X		
Hepatocellular carcinoma, multiple																									X		
Hepatocellular adenoma						X																					
Hepatocellular adenoma, multiple																									X		
Histiocytic sarcoma									X																		
Mesentery	+					+										+									+		
Pancreas	+	+	+	+	+	+	+	+	+	+	+	+	+	+	+	+	+	+	+	+	+	+	+	+	+	+	
Salivary glands	+	+	+	+	+	+	+	+	+	+	+	+	+	+	+	+	+	+	+	+	+	+	+	+	+	+	
Stomach, forestomach	+	+	+	+	+	+	+	+	+	+	+	+	+	+	+	+	+	+	+	+	+	+	+	+	+	+	
Squamous cell papilloma																											
Stomach, glandular	+	+	+	+	+	+	+	+	+	+	+	+	+	+	+	+	+	+	+	+	+	+	+	+	+	+	
Tooth																											
<b>Cardiovascular System</b>																											
Blood vessel	+	+	+	+	+	+	+	+	+	+	+	+	+	+	+	+	M	M	+	+	+	+	+	+	+	+	
Heart	+	+	+	+	+	+	+	+	+	+	+	+	+	+	+	+	+	+	+	+	+	+	+	+	+	+	
Histiocytic sarcoma										X																	
<b>Endocrine System</b>																											
Adrenal cortex	+	+	+	+	+	+	+	+	+	+	+	+	+	+	+	+	+	+	+	+	+	+	+	+	+	+	
Histiocytic sarcoma										X																	
Adrenal medulla	+	+	+	+	+	+	+	+	+	+	+	+	+	+	+	+	+	+	+	+	+	+	+	+	M	+	
Histiocytic sarcoma										X																	
Pheochromocytoma malignant																											
Pheochromocytoma benign										X																	
Islets, pancreatic	+	+	+	+	+	+	+	+	+	+	+	+	+	+	+	+	+	+	+	+	+	+	+	+	+	+	
Parathyroid gland	+	+	M	+	+	+	+	+	M	M	M	+	M	M	M	+	+	+	M	+	+	+	M	+	+		
Pituitary gland	+	+	+	+	+	+	+	+	+	+	+	+	+	+	+	+	+	+	+	+	+	+	+	+	+	+	
Pars distalis, adenoma									X				X	X	X					X			X	X			
Thyroid gland	+	+	+	+	+	+	+	+	+	+	+	+	+	+	+	+	+	+	+	+	+	+	+	+	+	+	
Follicular cell, adenoma																									X		
<b>General Body System</b>																											
Tissue NOS																								+		+	
Sarcoma																									X		

+: Tissue examined microscopically  
A: Autolysis precludes examination

M: Missing tissue  
I: Insufficient tissue

X: Lesion present  
Blank: Not examined







**TABLE D2**  
**Individual Animal Tumor Pathology of Female Mice in the 2-Year Inhalation Study of Acetonitrile: 0 ppm (continued)**

<b>Number of Days on Study</b>	0 4 4 5 5 5 6 6 6 6 6 6 6 6 6 6 6 6 7 7 7 7 7 7 7 7
	0 2 2 1 6 8 2 2 3 4 5 6 7 8 8 9 9 0 0 0 1 2 3 3 3
	5 6 6 7 9 1 2 3 5 1 8 4 8 1 1 4 9 0 6 6 0 0 5 5 5
<b>Carcass ID Number</b>	1 0 1 0 0 1 0 1 1 0 0 0 1 0 0 0 1 1 0 1 0 0 0 0 0
	1 6 1 9 8 0 8 1 0 9 9 6 0 6 9 7 0 0 8 2 9 8 6 6 6
	0 3 7 2 5 7 0 1 3 7 6 9 6 1 4 0 8 9 9 0 0 1 2 5 6
<b>Respiratory System</b>	
Larynx	+ +
Lung	+ +
Adenocarcinoma, metastatic, mammary gland	
Alveolar/bronchiolar adenoma	
Alveolar/bronchiolar adenoma, multiple	
Alveolar/bronchiolar carcinoma	
Hepatocellular carcinoma, metastatic, liver	
Histiocytic sarcoma	
Pheochromocytoma malignant, metastatic, adrenal medulla	
Nose	+ +
Trachea	+ +
<b>Special Senses System</b>	
Harderian gland	
Adenoma	
<b>Urinary System</b>	
Kidney	+ +
Histiocytic sarcoma	
Renal tubule, adenoma	
Renal tubule, carcinoma	
Urinary bladder	+ + + + + + + + + + + + M + + + + + + + + + + + +
<b>Systemic Lesions</b>	
Multiple organs	+ +
Histiocytic sarcoma	
Lymphoma malignant	
Lymphoma malignant lymphocytic	
Lymphoma malignant mixed	













**TABLE D2**  
**Individual Animal Tumor Pathology of Female Mice in the 2-Year Inhalation Study of Acetonitrile: 50 ppm (continued)**

<b>Number of Days on Study</b>	3	4	5	5	5	6	6	6	6	6	6	6	6	6	6	7	7	7	7	7	7	7	7	7	7	7	7	7
	6	3	4	7	9	0	2	2	3	4	6	6	6	8	8	1	1	3	3	3	3	3	3	3	3	3	3	3
	9	5	8	9	5	2	1	2	9	6	4	4	5	6	7	1	7	6	6	6	6	6	6	6	6	6	6	6
<b>Carcass ID Number</b>	2	2	1	1	2	2	2	2	1	2	2	2	2	1	1	2	2	1	1	1	1	1	1	1	1	1	1	1
	3	1	9	8	2	1	3	1	9	1	0	3	0	8	8	3	3	8	8	8	8	9	9	9	9	9	9	9
	7	6	9	4	3	1	9	4	8	2	3	4	9	2	7	8	5	6	8	9	0	1	2	3	4			
<b>Special Senses System</b>																												
Harderian gland																												+
Adenoma																												X
<b>Urinary System</b>																												
Kidney	A	+	+	+	+	+	+	+	+	+	+	+	+	+	+	+	+	+	+	+	+	+	+	+	+	+	+	+
Urinary bladder	A	+	+	+	+	+	+	+	+	+	+	+	+	+	+	+	+	+	+	+	+	+	+	+	+	+	+	+
<b>Systemic Lesions</b>																												
Multiple organs	+	+	+	+	+	+	+	+	+	+	+	+	+	+	+	+	+	+	+	+	+	+	+	+	+	+	+	+
Histiocytic sarcoma																												X
Lymphoma malignant lymphocytic	X		X				X						X	X		X												
Lymphoma malignant mixed				X											X											X		

**TABLE D2**  
**Individual Animal Tumor Pathology of Female Mice in the 2-Year Inhalation Study of Acetonitrile: 50 ppm (continued)**

<b>Number of Days on Study</b>	7 7	
	3 3	
	6 6	
<b>Carcass ID Number</b>	1 1 1 2	Total Tissues/ Tumors
	9 9 9 0 0 0 0 0 0 0 1 1 1 2 2 2 2 2 2 2 2 3 3 3 3	
	5 6 7 1 2 4 5 6 7 8 0 5 7 0 1 2 4 5 7 8 9 0 1 2 3	
<b>Special Senses System</b>		
Harderian gland		1
Adenoma		1
<b>Urinary System</b>		
Kidney	+ +	49
Urinary bladder	+ + + + + + + + + I + + + + + + + + + + + + + + + + + + +	48
<b>Systemic Lesions</b>		
Multiple organs	+ +	50
Histiocytic sarcoma		1
Lymphoma malignant lymphocytic		10
Lymphoma malignant mixed		7





**TABLE D2**  
**Individual Animal Tumor Pathology of Female Mice in the 2-Year Inhalation Study of Acetonitrile: 100 ppm (continued)**

Number of Days on Study	7 7																				Total Tissues/ Tumors
	3 6 6																				
Carcass ID Number	3 3																				Total Tissues/ Tumors
	1 1 1 1 1 1 2 2 2 2 3 3 3 3 4 4 4 4 4 4 5 5 5 5 0 2 3 4 6 7 0 4 6 7 1 4 7 8 1 2 4 5 7 8 9 0 1 6 7																				
<b>Alimentary System</b>																					
Esophagus	+ M + + +																				49
Gallbladder	+ + + + I + + + + + + + M + M + + + + + + + + + + +																				41
Intestine large, colon	+ +																				47
Intestine large, rectum	+ +																				48
Intestine large, cecum	+ +																				48
Intestine small, duodenum	+ + + + I +																				44
Intestine small, jejunum	+ +																				46
Intestine small, ileum	+ +																				45
Liver	+ +																				50
Hemangiosarcoma, multiple																					1
Hepatocellular carcinoma																					4
Hepatocellular carcinoma, multiple	X																				2
Hepatocellular adenoma	X																				6
Hepatocellular adenoma, multiple	X X X X X																				2
Histiocytic sarcoma																					1
Mesentery	+ +																				6
Fat, carcinoma, metastatic, pancreas																					1
Pancreas	+ +																				50
Adenocarcinoma																					1
Fibrosarcoma																					1
Salivary glands	+ +																				50
Stomach, forestomach	+ +																				50
Carcinoma, metastatic, pancreas																					1
Squamous cell papilloma	X																				1
Stomach, glandular	+ +																				50
Carcinoma, metastatic, pancreas																					1
<b>Cardiovascular System</b>																					
Blood vessel	+ + + + + + M + + + + + + + + + + + + + + + + + +																				47
Heart	+ +																				49
<b>Endocrine System</b>																					
Adrenal cortex	+ +																				50
Adrenal medulla	+ +																				50
Islets, pancreatic	+ +																				50
Adenoma	X																				2
Parathyroid gland	+ + M M M + + M M M M + M M M + M + M M M M + + +																				22
Pituitary gland	+ +																				50
Pars distalis, adenoma	X X X X X X X X X X																				15
Thyroid gland	+ +																				50
Bilateral, follicular cell, adenoma																					1
Follicular cell, adenoma	X																				1
<b>General Body System</b>																					
Tissue NOS	+																				1
<b>Genital System</b>																					
Clitoral gland	+ M + + + M + + M + M M + + + + + + + + + M + + + +																				39
Ovary	+ +																				48
Cystadenoma																					1
Uterus	+ +																				50
Polyp stromal	X X																				3













**TABLE D3**  
**Statistical Analysis of Primary Neoplasms in Female Mice in the 2-Year Inhalation Study of Acetonitrile**

	0 ppm	50 ppm	100 ppm	200 ppm
<b>Adrenal Medulla: Benign or Malignant Pheochromocytoma</b>				
Overall rate <sup>a</sup>	3/48 (6%)	0/48 (0%)	0/50 (0%)	0/49 (0%)
Adjusted rate <sup>b</sup>	9.3%	0.0%	0.0%	0.0%
Terminal rate <sup>c</sup>	2/27 (7%)	0/33 (0%)	0/29 (0%)	0/32 (0%)
First incidence (days)	426	— <sup>e</sup>	—	—
Life table test <sup>d</sup>	P=0.044N	P=0.100N	P=0.113N	P=0.106N
Logistic regression test <sup>d</sup>	P=0.029N	P=0.141N	P=0.165N	P=0.091N
Cochran-Armitage test <sup>d</sup>	P=0.045N			
Fisher exact test <sup>d</sup>		P=0.121N	P=0.114N	P=0.117N
<b>Harderian Gland: Adenoma</b>				
Overall rate	3/50 (6%)	1/50 (2%)	1/50 (2%)	0/50 (0%)
Adjusted rate	8.3%	3.0%	3.4%	0.0%
Terminal rate	1/28 (4%)	1/33 (3%)	1/29 (3%)	0/32 (0%)
First incidence (days)	623	735 (T)	735 (T)	—
Life table test	P=0.071N	P=0.283N	P=0.296N	P=0.125N
Logistic regression test	P=0.074N	P=0.301N	P=0.303N	P=0.122N
Cochran-Armitage test	P=0.073N			
Fisher exact test		P=0.309N	P=0.309N	P=0.121N
<b>Harderian Gland: Adenoma or Carcinoma</b>				
Overall rate	3/50 (6%)	1/50 (2%)	2/50 (4%)	1/50 (2%)
Adjusted rate	8.3%	3.0%	6.9%	3.1%
Terminal rate	1/28 (4%)	1/33 (3%)	2/29 (7%)	1/32 (3%)
First incidence (days)	623	735 (T)	735 (T)	735 (T)
Life table test	P=0.266N	P=0.283N	P=0.485N	P=0.298N
Logistic regression test	P=0.289N	P=0.301N	P=0.487N	P=0.313N
Cochran-Armitage test	P=0.279N			
Fisher exact test		P=0.309N	P=0.500N	P=0.309N
<b>Liver: Hepatocellular Adenoma</b>				
Overall rate	4/49 (8%)	8/50 (16%)	8/50 (16%)	6/49 (12%)
Adjusted rate	12.0%	22.4%	25.6%	18.8%
Terminal rate	2/28 (7%)	6/33 (18%)	6/29 (21%)	6/32 (19%)
First incidence (days)	569	664	708	735 (T)
Life table test	P=0.466	P=0.248	P=0.209	P=0.433
Logistic regression test	P=0.390	P=0.191	P=0.211	P=0.346
Cochran-Armitage test	P=0.411			
Fisher exact test		P=0.188	P=0.188	P=0.370
<b>Liver: Hepatocellular Carcinoma</b>				
Overall rate	7/49 (14%)	6/50 (12%)	6/50 (12%)	5/49 (10%)
Adjusted rate	23.1%	15.8%	16.4%	13.6%
Terminal rate	5/28 (18%)	3/33 (9%)	2/29 (7%)	3/32 (9%)
First incidence (days)	706	595	570	510
Life table test	P=0.309N	P=0.397N	P=0.456N	P=0.323N
Logistic regression test	P=0.340N	P=0.475N	P=0.457N	P=0.399N
Cochran-Armitage test	P=0.332N			
Fisher exact test		P=0.484N	P=0.484N	P=0.380N



**TABLE D3**  
**Statistical Analysis of Primary Neoplasms in Female Mice in the 2-Year Inhalation Study of Acetonitrile (continued)**

	0 ppm	50 ppm	100 ppm	200 ppm
<b>Liver: Hepatocellular Adenoma or Carcinoma</b>				
Overall rate	9/49 (18%)	13/50 (26%)	13/50 (26%)	10/49 (20%)
Adjusted rate	28.0%	33.5%	36.9%	28.5%
Terminal rate	6/28 (21%)	8/33 (24%)	8/29 (28%)	8/32 (25%)
First incidence (days)	569	595	570	510
Life table test	P=0.503N	P=0.359	P=0.290	P=0.585
Logistic regression test	P=0.489	P=0.257	P=0.284	P=0.466
Cochran-Armitage test	P=0.529			
Fisher exact test		P=0.251	P=0.251	P=0.500
<b>Lung: Alveolar/bronchiolar Adenoma</b>				
Overall rate	7/49 (14%)	2/50 (4%)	2/50 (4%)	0/49 (0%)
Adjusted rate	25.0%	6.1%	6.9%	0.0%
Terminal rate	7/28 (25%)	2/33 (6%)	2/29 (7%)	0/32 (0%)
First incidence (days)	735 (T)	735 (T)	735 (T)	—
Life table test	P=0.003N	P=0.044N	P=0.067N	P=0.005N
Logistic regression test	P=0.003N	P=0.044N	P=0.067N	P=0.005N
Cochran-Armitage test	P=0.005N			
Fisher exact test		P=0.075N	P=0.075N	P=0.006N
<b>Lung: Alveolar/bronchiolar Adenoma or Carcinoma</b>				
Overall rate	8/49 (16%)	3/50 (6%)	2/50 (4%)	1/49 (2%)
Adjusted rate	27.3%	9.1%	6.9%	3.1%
Terminal rate	7/28 (25%)	3/33 (9%)	2/29 (7%)	1/32 (3%)
First incidence (days)	706	735 (T)	735 (T)	735 (T)
Life table test	P=0.007N	P=0.057N	P=0.039N	P=0.010N
Logistic regression test	P=0.007N	P=0.065N	P=0.032N	P=0.012N
Cochran-Armitage test	P=0.009N			
Fisher exact test		P=0.094N	P=0.043N	P=0.015N
<b>Mammary Gland: Carcinoma</b>				
Overall rate	3/50 (6%)	0/50 (0%)	3/50 (6%)	1/50 (2%)
Adjusted rate	8.9%	0.0%	7.8%	3.1%
Terminal rate	1/28 (4%)	0/33 (0%)	0/29 (0%)	1/32 (3%)
First incidence (days)	641	—	650	735 (T)
Life table test	P=0.358N	P=0.109N	P=0.612N	P=0.283N
Logistic regression test	P=0.379N	P=0.118N	P=0.663	P=0.316N
Cochran-Armitage test	P=0.373N			
Fisher exact test		P=0.121N	P=0.661N	P=0.309N
<b>Pituitary Gland (Pars Distalis): Adenoma</b>				
Overall rate	14/48 (29%)	14/49 (29%)	15/50 (30%)	6/48 (13%)
Adjusted rate	41.8%	38.3%	42.2%	17.4%
Terminal rate	9/27 (33%)	11/33 (33%)	10/29 (34%)	4/32 (13%)
First incidence (days)	622	646	583	664
Life table test	P=0.023N	P=0.406N	P=0.582N	P=0.027N
Logistic regression test	P=0.033N	P=0.516N	P=0.572N	P=0.041N
Cochran-Armitage test	P=0.030N			
Fisher exact test		P=0.563N	P=0.552	P=0.038N

TABLE D3

Statistical Analysis of Primary Neoplasms in Female Mice in the 2-Year Inhalation Study of Acetonitrile (continued)

	0 ppm	50 ppm	100 ppm	200 ppm
<b>Stomach (Forestomach): Squamous Cell Papilloma</b>				
Overall rate	1/50 (2%)	0/50 (0%)	1/50 (2%)	3/50 (6%)
Adjusted rate	3.6%	0.0%	3.4%	9.4%
Terminal rate	1/28 (4%)	0/33 (0%)	1/29 (3%)	3/32 (9%)
First incidence (days)	735 (T)	–	735 (T)	735 (T)
Life table test	P=0.108	P=0.467N	P=0.754N	P=0.353
Logistic regression test	P=0.107	P=0.467N	P=0.754N	P=0.353
Cochran-Armitage test	P=0.097			
Fisher exact test		P=0.500N	P=0.753N	P=0.309
<b>Thyroid Gland (Follicular Cell): Adenoma</b>				
Overall rate	2/49 (4%)	3/48 (6%)	2/50 (4%)	1/49 (2%)
Adjusted rate	7.1%	8.3%	6.4%	3.1%
Terminal rate	2/28 (7%)	2/33 (6%)	1/29 (3%)	1/32 (3%)
First incidence (days)	735 (T)	639	712	735 (T)
Life table test	P=0.287N	P=0.562	P=0.673N	P=0.453N
Logistic regression test	P=0.320N	P=0.508	P=0.667N	P=0.453N
Cochran-Armitage test	P=0.309N			
Fisher exact test		P=0.490	P=0.684N	P=0.500N
<b>Uterus: Stromal Polyp</b>				
Overall rate	2/50 (4%)	2/50 (4%)	3/50 (6%)	3/50 (6%)
Adjusted rate	6.9%	6.1%	9.1%	9.4%
Terminal rate	1/28 (4%)	2/33 (6%)	2/29 (7%)	3/32 (9%)
First incidence (days)	720	735 (T)	664	735 (T)
Life table test	P=0.404	P=0.637N	P=0.524	P=0.560
Logistic regression test	P=0.365	P=0.662N	P=0.533	P=0.530
Cochran-Armitage test	P=0.371			
Fisher exact test		P=0.691N	P=0.500	P=0.500
<b>Uterus: Stromal Polyp or Stromal Sarcoma</b>				
Overall rate	2/50 (4%)	3/50 (6%)	3/50 (6%)	3/50 (6%)
Adjusted rate	6.9%	8.3%	9.1%	9.4%
Terminal rate	1/28 (4%)	2/33 (6%)	2/29 (7%)	3/32 (9%)
First incidence (days)	720	639	664	735 (T)
Life table test	P=0.468	P=0.558	P=0.524	P=0.560
Logistic regression test	P=0.419	P=0.515	P=0.533	P=0.530
Cochran-Armitage test	P=0.438			
Fisher exact test		P=0.500	P=0.500	P=0.500
<b>All Organs: Hemangiosarcoma</b>				
Overall rate	3/50 (6%)	0/50 (0%)	1/50 (2%)	3/50 (6%)
Adjusted rate	8.9%	0.0%	3.4%	8.4%
Terminal rate	1/28 (4%)	0/33 (0%)	1/29 (3%)	2/32 (6%)
First incidence (days)	622	–	735 (T)	509
Life table test	P=0.438	P=0.107N	P=0.288N	P=0.632N
Logistic regression test	P=0.424	P=0.119N	P=0.294N	P=0.662
Cochran-Armitage test	P=0.423			
Fisher exact test		P=0.121N	P=0.309N	P=0.661N

**TABLE D3**  
**Statistical Analysis of Primary Neoplasms in Female Mice in the 2-Year Inhalation Study of Acetonitrile (continued)**

	0 ppm	50 ppm	100 ppm	200 ppm
<b>All Organs: Hemangioma or Hemangiosarcoma</b>				
Overall rate	5/50 (10%)	2/50 (4%)	1/50 (2%)	3/50 (6%)
Adjusted rate	15.7%	6.1%	3.4%	8.4%
Terminal rate	3/28 (11%)	2/33 (6%)	1/29 (3%)	2/32 (6%)
First incidence (days)	622	735 (T)	735 (T)	509
Life table test	P=0.295N	P=0.168N	P=0.095N	P=0.317N
Logistic regression test	P=0.329N	P=0.201N	P=0.090N	P=0.366N
Cochran-Armitage test	P=0.319N			
Fisher exact test		P=0.218N	P=0.102N	P=0.357N
<b>All Organs: Malignant Lymphoma (Lymphocytic, Mixed, or Undifferentiated Cell Type)</b>				
Overall rate	11/50 (22%)	17/50 (34%)	16/50 (32%)	14/50 (28%)
Adjusted rate	32.1%	40.6%	40.9%	40.6%
Terminal rate	6/28 (21%)	9/33 (27%)	8/29 (28%)	12/32 (38%)
First incidence (days)	581	369	552	444
Life table test	P=0.456	P=0.247	P=0.256	P=0.424
Logistic regression test	P=0.365	P=0.138	P=0.211	P=0.281
Cochran-Armitage test	P=0.396			
Fisher exact test		P=0.133	P=0.184	P=0.322
<b>All Organs: Benign Neoplasms</b>				
Overall rate	29/50 (58%)	25/50 (50%)	25/50 (50%)	19/50 (38%)
Adjusted rate	73.5%	65.4%	66.6%	54.0%
Terminal rate	18/28 (64%)	20/33 (61%)	17/29 (59%)	16/32 (50%)
First incidence (days)	426	639	583	644
Life table test	P=0.022N	P=0.125N	P=0.229N	P=0.019N
Logistic regression test	P=0.042N	P=0.219N	P=0.187N	P=0.047N
Cochran-Armitage test	P=0.031N			
Fisher exact test		P=0.274N	P=0.274N	P=0.036N
<b>All Organs: Malignant Neoplasms</b>				
Overall rate	24/50 (48%)	23/50 (46%)	27/50 (54%)	24/50 (48%)
Adjusted rate	59.2%	51.5%	60.4%	60.5%
Terminal rate	12/28 (43%)	12/33 (36%)	12/29 (41%)	17/32 (53%)
First incidence (days)	426	369	552	444
Life table test	P=0.519N	P=0.340N	P=0.473	P=0.453N
Logistic regression test	P=0.475	P=0.506N	P=0.364	P=0.548
Cochran-Armitage test	P=0.481			
Fisher exact test		P=0.500N	P=0.345	P=0.579N

**TABLE D3**  
**Statistical Analysis of Primary Neoplasms in Female Mice in the 2-Year Inhalation Study of Acetonitrile (continued)**

	0 ppm	50 ppm	100 ppm	200 ppm
<b>All Organs: Benign or Malignant Neoplasms</b>				
Overall rate	36/50 (72%)	36/50 (72%)	38/50 (76%)	33/50 (66%)
Adjusted rate	81.6%	78.0%	82.2%	78.2%
Terminal rate	20/28 (71%)	23/33 (70%)	21/29 (72%)	23/32 (72%)
First incidence (days)	426	369	552	444
Life table test	P=0.263N	P=0.314N	P=0.558N	P=0.234N
Logistic regression test	P=0.345N	P=0.548N	P=0.497	P=0.405N
Cochran-Armitage test	P=0.289N			
Fisher exact test		P=0.588N	P=0.410	P=0.333N

(T) Terminal sacrifice

- <sup>a</sup> Number of neoplasm-bearing animals/number of animals examined. Denominator is number of animals examined microscopically for adrenal gland, liver, lung, pituitary gland, and thyroid gland; for other tissues, denominator is number of animals necropsied.
- <sup>b</sup> Kaplan-Meier estimated neoplasm incidence at the end of the study after adjustment for intercurrent mortality
- <sup>c</sup> Observed incidence at terminal kill
- <sup>d</sup> Beneath the control incidence are the P values associated with the trend test. Beneath the exposed group incidence are the P values corresponding to pairwise comparisons between the controls and that exposed group. The life table test regards neoplasms in animals dying prior to terminal kill as being (directly or indirectly) the cause of death. The logistic regression test regards these lesions as nonfatal. The Cochran-Armitage and Fisher exact tests compare directly the overall incidence rates. For all tests, a negative trend or a lower incidence in an exposure group is indicated by N.
- <sup>e</sup> Not applicable; no neoplasms in animal group

**TABLE D4a**  
**Historical Incidence of Alveolar/bronchiolar Neoplasms in Untreated Female B6C3F<sub>1</sub> Mice<sup>a</sup>**

Study	Incidence in Controls		
	Adenoma	Carcinoma	Adenoma or Carcinoma
<b>Historical Incidence at Battelle Pacific Northwest Laboratories</b>			
1,3-Butadiene	4/50	0/50	4/50
Allyl Glycidyl Ether	0/50	0/50	0/50
2-Chloroacetophenone	4/50	3/50	6/50
<i>l</i> -Epinephrine Hydrochloride	3/50	2/50	5/50
Chloroethane	2/49	3/49	5/49
Hexachlorocyclopentadiene	4/48	3/48	7/48
<i>o</i> -Chlorobenzalmalonitrile (CS2)	4/50	1/50	5/50
<b>Overall Historical Incidence</b>			
Total	40/659 (6.1%)	19/659 (2.9%)	58/659 (8.8%)
Standard deviation	2.8%	2.5%	3.5%
Range	0%-10%	0%-6%	0%-15%

<sup>a</sup> Data as of 27 April 1993

**TABLE D4b**  
**Historical Incidence of Hepatocellular Neoplasms in Untreated Female B6C3F<sub>1</sub> Mice<sup>a</sup>**

Study	Incidence in Controls		
	Adenoma	Carcinoma	Adenoma or Carcinoma
<b>Historical Incidence at Battelle Pacific Northwest Laboratories</b>			
1,3-Butadiene	11/49	4/49	15/49
Allyl Glycidyl Ether	1/50	5/50	6/50
2-Chloroacetophenone	4/50	8/50	12/50
<i>l</i> -Epinephrine Hydrochloride	2/50	1/50	3/50
Chloroethane	0/49	3/49	3/49
Hexachlorocyclopentadiene	5/49	4/49	9/49
<i>o</i> -Chlorobenzalmalonitrile (CS2)	4/50	7/50	11/50
<b>Overall Historical Incidence</b>			
Total	56/657 (8.5%)	57/657 (8.7%)	111/657 (16.9%)
Standard deviation	6.2%	4.8%	8.7%
Range	0%-22%	0%-16%	3%-31%

<sup>a</sup> Data as of 27 April 1993

**TABLE D4c**  
**Historical Incidence of Forestomach Squamous Cell Papilloma in Untreated Female B6C3F<sub>1</sub> Mice<sup>a</sup>**

Study	Incidence in Controls
<b>Historical Incidence at Battelle Pacific Northwest Laboratories</b>	
1,3-Butadiene	0/50
Allyl Glycidyl Ether	1/50
2-Chloroacetophenone	0/50
l-Epinephrine Hydrochloride	0/50
Chloroethane	0/49
Hexachlorocyclopentadiene	0/49
o-Chlorobenzalmalononitrile (CS2)	2/50
<b>Overall Historical Incidence</b>	
Total	8/661 (1.2%)
Standard deviation	2.0%
Range	0%-6%

<sup>a</sup> Data as of 27 April 1993

**TABLE D5**  
**Summary of the Incidence of Nonneoplastic Lesions in Female Mice in the 2-Year Inhalation Study of Acetonitrile<sup>a</sup>**

	0 ppm	50 ppm	100 ppm	200 ppm
<b>Disposition Summary</b>				
Animals initially in study	60	60	60	60
<i>15-Month interim evaluation</i>	10	10	10	10
Early deaths				
Accidental death	1			
Moribund	15	12	13	13
Natural deaths	6	5	8	5
Survivors				
Died last week of study		1		
Terminal sacrifice	28	32	29	32
Animals examined microscopically	60	60	60	60
<b>15-Month Interim Evaluation</b>				
<b>Alimentary System</b>				
Gallbladder	(10)	(10)	(10)	(10)
Inflammation, suppurative			1 (10%)	
Liver	(10)	(10)	(10)	(10)
Basophilic focus	1 (10%)			
Eosinophilic focus				1 (10%)
Necrosis	1 (10%)			
Bile duct, cyst	1 (10%)			
Mesentery	(2)		(1)	
Fat, necrosis	1 (50%)		1 (100%)	
Pancreas	(10)	(10)	(10)	(10)
Inflammation, chronic	1 (10%)			
Duct, ectasia	1 (10%)			
Salivary glands	(10)	(10)	(10)	(10)
Inflammation, chronic	1 (10%)			
Stomach, forestomach	(10)	(10)	(10)	(10)
Diverticulum		1 (10%)		
Hyperplasia, squamous		1 (10%)		6 (60%)
<b>Cardiovascular System</b>				
Heart	(10)	(10)	(10)	(10)
Cardiomyopathy			1 (10%)	
<b>Endocrine System</b>				
Adrenal cortex	(10)	(10)	(10)	(10)
Hyperplasia	1 (10%)			
Pituitary gland	(10)	(10)	(10)	(10)
Pars distalis, cyst	1 (10%)			
Pars distalis, hyperplasia	2 (20%)		4 (40%)	1 (10%)
<b>Genital System</b>				
Ovary	(10)	(10)	(10)	(9)
Atrophy		1 (10%)		
Cyst	3 (30%)	4 (40%)	2 (20%)	1 (11%)
Uterus	(10)	(10)	(10)	(10)
Angiectasis				1 (10%)
Hyperplasia, cystic	9 (90%)	9 (90%)	9 (90%)	8 (80%)

<sup>a</sup> Number of animals examined microscopically at the site and the number of animals with lesion

**TABLE D5**  
**Summary of the Incidence of Nonneoplastic Lesions in Female Mice in the 2-Year Inhalation Study of Acetonitrile**  
 (continued)

	0 ppm	50 ppm	100 ppm	200 ppm
<b>15-Month Interim Evaluation</b> (continued)				
<b>Hematopoietic System</b>				
Lymph node, bronchial	(10)	(10)	(9)	(10)
Hyperplasia	1 (10%)	1 (10%)		
Lymph node, mesenteric	(10)	(9)	(10)	(8)
Angiectasis			1 (10%)	
Hyperplasia			2 (20%)	
Spleen	(10)	(10)	(10)	(10)
Hyperplasia, lymphoid		1 (10%)		
<b>Musculoskeletal System</b>				
Bone	(10)	(10)	(10)	(10)
Fibrous osteodystrophy	1 (10%)			1 (10%)
<b>Nervous System</b>				
Brain	(10)	(10)	(10)	(10)
Mineralization	1 (10%)	3 (30%)	1 (10%)	
<b>Respiratory System</b>				
Lung	(10)	(10)	(10)	(10)
Embolus		1 (10%)		
Hemorrhage		1 (10%)	3 (30%)	
Perivascular, infiltration cellular, mononuclear cell	1 (10%)			
<b>Urinary System</b>				
Kidney	(10)	(10)	(10)	(10)
Nephropathy	1 (10%)	1 (10%)	1 (10%)	2 (20%)
Urinary bladder	(9)	(9)	(9)	(10)
Inflammation, chronic	1 (11%)		1 (11%)	
<b>Systems Examined With No Lesions Observed</b>				
<b>General Body System</b>				
<b>Integumentary System</b>				
<b>Special Senses System</b>				
<b>2-Year Study</b>				
<b>Alimentary System</b>				
Gallbladder	(42)	(45)	(41)	(46)
Hyperplasia			1 (2%)	
Inflammation, suppurative		2 (4%)		1 (2%)
Intestine large, colon	(46)	(45)	(47)	(48)
Hemorrhage	1 (2%)			
Necrosis	1 (2%)			
Intestine large, cecum	(45)	(46)	(48)	(46)
Hemorrhage	1 (2%)			
Necrosis	1 (2%)			



TABLE D5

Summary of the Incidence of Nonneoplastic Lesions in Female Mice in the 2-Year Inhalation Study of Acetonitrile  
(continued)

	0 ppm	50 ppm	100 ppm	200 ppm
<b>2-Year Study</b> (continued)				
<b>Alimentary System</b> (continued)				
Intestine small, duodenum	(42)	(44)	(44)	(45)
Inflammation, suppurative			1 (2%)	
Intestine small, jejunum	(44)	(46)	(46)	(47)
Peyer's patch, hyperplasia	1 (2%)			
Intestine small, ileum	(45)	(47)	(45)	(47)
Amyloid deposition			1 (2%)	
Liver	(49)	(50)	(50)	(49)
Angiectasis			1 (2%)	
Basophilic focus	1 (2%)	3 (6%)		
Clear cell focus		1 (2%)	1 (2%)	
Cyst		1 (2%)		
Cytomegaly		1 (2%)		
Degeneration, cystic	1 (2%)			
Degeneration, fatty		2 (4%)	1 (2%)	
Eosinophilic focus	5 (10%)	3 (6%)	3 (6%)	3 (6%)
Focal cellular change	1 (2%)		2 (4%)	
Hematopoietic cell proliferation	8 (16%)	2 (4%)	1 (2%)	4 (8%)
Hyperplasia, lymphoid	1 (2%)			
Infarct	1 (2%)			1 (2%)
Infiltration cellular, mononuclear cell		2 (4%)		
Karyomegaly		1 (2%)		1 (2%)
Mitotic alteration			2 (4%)	1 (2%)
Mixed cell focus	4 (8%)	4 (8%)	1 (2%)	
Necrosis	4 (8%)	4 (8%)	8 (16%)	2 (4%)
Pigmentation, hemosiderin		1 (2%)		
Regeneration		1 (2%)		
Bile duct, cyst				1 (2%)
Bile duct, degeneration	1 (2%)			
Centrilobular, necrosis	1 (2%)		1 (2%)	3 (6%)
Serosa, inflammation, suppurative	2 (4%)			
Mesentery	(8)	(16)	(6)	(5)
Angiectasis	1 (13%)			
Inflammation, chronic	2 (25%)			
Fat, necrosis	6 (75%)	9 (56%)	2 (33%)	4 (80%)
Pancreas	(49)	(49)	(50)	(48)
Amyloid deposition		1 (2%)		
Atrophy	2 (4%)	2 (4%)	1 (2%)	
Focal cellular change	2 (4%)	1 (2%)	2 (4%)	
Hyperplasia		1 (2%)		1 (2%)
Hyperplasia, lymphoid	1 (2%)			
Inflammation, chronic	2 (4%)	1 (2%)	1 (2%)	
Duct, ectasia	2 (4%)			
Duct, inflammation, chronic	2 (4%)			
Salivary glands	(49)	(50)	(50)	(49)
Inflammation, suppurative		1 (2%)		
Stomach, forestomach	(49)	(50)	(50)	(48)
Angiectasis	1 (2%)			
Hyperkeratosis				5 (10%)
Hyperplasia, squamous	2 (4%)	7 (14%)	9 (18%)	19 (40%)
Inflammation, suppurative	1 (2%)	3 (6%)	4 (8%)	3 (6%)
Necrosis			1 (2%)	
Ulcer	1 (2%)	2 (4%)	2 (4%)	5 (10%)
Epithelium, hyperplasia	1 (2%)			

TABLE D5

Summary of the Incidence of Nonneoplastic Lesions in Female Mice in the 2-Year Inhalation Study of Acetonitrile  
(continued)

	0 ppm	50 ppm	100 ppm	200 ppm
<b>2-Year Study</b> (continued)				
<b>Alimentary System</b> (continued)				
Stomach, glandular	(49)	(48)	(50)	(48)
Hyperplasia		2 (4%)		
Inflammation, suppurative	1 (2%)	1 (2%)		
Mineralization		1 (2%)		
Tooth				(1)
Dysplasia				1 (100%)
<b>Cardiovascular System</b>				
Blood vessel	(42)	(43)	(47)	(45)
Mineralization		1 (2%)	1 (2%)	
Thrombosis		1 (2%)		
Heart	(49)	(50)	(49)	(50)
Angiectasis			1 (2%)	
Cardiomyopathy	16 (33%)	19 (38%)	22 (45%)	15 (30%)
Hyperplasia, atypical	1 (2%)		1 (2%)	
Inflammation, suppurative				1 (2%)
<b>Endocrine System</b>				
Adrenal cortex	(49)	(49)	(50)	(49)
Cyst		3 (6%)	1 (2%)	1 (2%)
Hematopoietic cell proliferation	2 (4%)	2 (4%)	1 (2%)	
Hyperplasia	3 (6%)	2 (4%)		
Hypertrophy	3 (6%)	4 (8%)	7 (14%)	3 (6%)
Capsule, hyperplasia	1 (2%)			1 (2%)
Adrenal medulla	(48)	(48)	(50)	(49)
Hyperplasia	2 (4%)	2 (4%)	3 (6%)	2 (4%)
Islets, pancreatic	(49)	(49)	(50)	(48)
Hyperplasia	2 (4%)	5 (10%)		1 (2%)
Pituitary gland	(48)	(49)	(50)	(48)
Pars distalis, cyst	3 (6%)	3 (6%)	1 (2%)	1 (2%)
Pars distalis, hyperplasia	17 (35%)	16 (33%)	20 (40%)	20 (42%)
Pars distalis, inflammation, chronic				1 (2%)
Pars intermedia, hyperplasia			1 (2%)	
Thyroid gland	(49)	(48)	(50)	(49)
Inflammation				1 (2%)
Inflammation, suppurative		1 (2%)		
Follicle, cyst	1 (2%)	1 (2%)		3 (6%)
Follicular cell, hyperplasia	12 (24%)	6 (13%)	9 (18%)	6 (12%)
<b>General Body System</b>				
None				

**TABLE D5**  
**Summary of the Incidence of Nonneoplastic Lesions in Female Mice in the 2-Year Inhalation Study of Acetonitrile**  
 (continued)

	0 ppm	50 ppm	100 ppm	200 ppm
<b>2-Year Study (continued)</b>				
<b>Genital System</b>				
Clitoral gland	(32)	(34)	(39)	(37)
Atrophy	1 (3%)			
Ovary	(48)	(47)	(48)	(48)
Abscess	4 (8%)			
Amyloid deposition	1 (2%)	1 (2%)		
Angiectasis	3 (6%)	1 (2%)	2 (4%)	
Atrophy	17 (35%)	18 (38%)	20 (42%)	13 (27%)
Cyst	16 (33%)	14 (30%)	16 (33%)	12 (25%)
Mineralization	1 (2%)			
Germinal epithelium, hyperplasia				1 (2%)
Interstitial, hyperplasia				1 (2%)
Uterus	(49)	(49)	(50)	(49)
Amyloid deposition	1 (2%)			
Angiectasis			1 (2%)	1 (2%)
Dilatation		2 (4%)	1 (2%)	
Hyperplasia, cystic	48 (98%)	44 (90%)	46 (92%)	44 (90%)
Inflammation, suppurative	1 (2%)		2 (4%)	1 (2%)
Thrombosis			1 (2%)	
Arteriole, hypertrophy				1 (2%)
Artery, inflammation, chronic			1 (2%)	
Myometrium, hyperplasia		1 (2%)		
<b>Hematopoietic System</b>				
Bone marrow	(49)	(49)	(50)	(49)
Hyperplasia, megakaryocyte				1 (2%)
Hyperplasia, neutrophil	6 (12%)	1 (2%)	3 (6%)	3 (6%)
Lymph node	(7)	(9)	(9)	(1)
Axillary, hyperplasia			1 (11%)	
Iliac, hemorrhage		1 (11%)		
Iliac, hyperplasia	2 (29%)	1 (11%)	1 (11%)	
Popliteal, hyperplasia			1 (11%)	
Renal, angiectasis			1 (11%)	
Renal, congestion		1 (11%)		
Lymph node, bronchial	(38)	(44)	(42)	(36)
Erythrophagocytosis		1 (2%)		
Hematopoietic cell proliferation	2 (5%)			
Hyperplasia	10 (26%)	3 (7%)	7 (17%)	4 (11%)
Lymph node, mandibular	(35)	(39)	(44)	(33)
Hyperplasia	5 (14%)		4 (9%)	5 (15%)
Lymph node, mesenteric	(44)	(44)	(47)	(43)
Amyloid deposition			1 (2%)	
Angiectasis	1 (2%)	1 (2%)	1 (2%)	
Congestion	2 (5%)	1 (2%)		
Hematopoietic cell proliferation	1 (2%)			
Hemorrhage			1 (2%)	
Hyperplasia	3 (7%)	5 (11%)	7 (15%)	4 (9%)
Hyperplasia, histiocytic	1 (2%)			
Inflammation, chronic	1 (2%)			

TABLE D5

Summary of the Incidence of Nonneoplastic Lesions in Female Mice in the 2-Year Inhalation Study of Acetonitrile  
(continued)

	0 ppm	50 ppm	100 ppm	200 ppm
<b>2-Year Study</b> (continued)				
<b>Hematopoietic System</b> (continued)				
Lymph node, mediastinal	(36)	(35)	(40)	(34)
Erythrophagocytosis		1 (3%)		
Hematopoietic cell proliferation	2 (6%)	1 (3%)		
Hyperplasia	6 (17%)	1 (3%)	10 (25%)	5 (15%)
Inflammation, suppurative	2 (6%)			
Spleen	(49)	(49)	(50)	(48)
Amyloid deposition			1 (2%)	1 (2%)
Congestion	1 (2%)			
Fibrosis		1 (2%)		
Hematopoietic cell proliferation	12 (24%)	12 (24%)	15 (30%)	11 (23%)
Hemorrhage	1 (2%)			
Hyperplasia, lymphoid	14 (29%)	14 (29%)	13 (26%)	5 (10%)
Capsule, fibrosis			1 (2%)	
Thymus	(44)	(48)	(46)	(41)
Angiectasis		1 (2%)	2 (4%)	1 (2%)
Atrophy	5 (11%)	2 (4%)	1 (2%)	5 (12%)
Developmental malformation		1 (2%)		
Hyperplasia, lymphoid	6 (14%)	5 (10%)	12 (26%)	8 (20%)
Necrosis		1 (2%)		1 (2%)
Epithelial cell, hyperplasia			2 (4%)	1 (2%)
<b>Integumentary System</b>				
Mammary gland	(49)	(47)	(50)	(48)
Hyperplasia	1 (2%)	2 (4%)	2 (4%)	1 (2%)
Skin	(49)	(50)	(50)	(49)
Inflammation, suppurative		1 (2%)		2 (4%)
Sebaceous gland, hyperplasia			1 (2%)	
Subcutaneous tissue, inflammation, chronic	1 (2%)		1 (2%)	1 (2%)
<b>Musculoskeletal System</b>				
Bone	(49)	(50)	(50)	(50)
Fibrous osteodystrophy	26 (53%)	18 (36%)	16 (32%)	18 (36%)
Fracture			1 (2%)	
Inflammation, chronic			1 (2%)	
Skeletal muscle		(1)	(1)	(1)
Hemorrhage			1 (100%)	1 (100%)
Inflammation		1 (100%)	1 (100%)	
<b>Nervous System</b>				
Brain	(49)	(50)	(50)	(49)
Hemorrhage				1 (2%)
Inflammation	1 (2%)			
Inflammation, chronic	1 (2%)	1 (2%)		3 (6%)
Mineralization	27 (55%)	28 (56%)	27 (54%)	20 (41%)
Necrosis	1 (2%)			
Pigmentation, hemosiderin			1 (2%)	

**TABLE D5**  
**Summary of the Incidence of Nonneoplastic Lesions in Female Mice in the 2-Year Inhalation Study of Acetonitrile**  
 (continued)

	0 ppm	50 ppm	100 ppm	200 ppm
<b>2-Year Study (continued)</b>				
<b>Respiratory System</b>				
Lung	(49)	(50)	(50)	(49)
Hemorrhage	4 (8%)		2 (4%)	4 (8%)
Infiltration cellular, mononuclear cell		1 (2%)		
Inflammation, acute	1 (2%)			1 (2%)
Inflammation, suppurative	1 (2%)			
Thrombosis	1 (2%)			2 (4%)
Alveolar epithelium, hyperplasia	3 (6%)	4 (8%)	2 (4%)	1 (2%)
Alveolus, infiltration cellular, histiocyte	1 (2%)	3 (6%)	2 (4%)	1 (2%)
Arteriole, inflammation			2 (4%)	
Artery, mediastinum, inflammation	1 (2%)			
Mediastinum, hemorrhage	1 (2%)			
Mediastinum, inflammation, suppurative	1 (2%)			
Perivascular, infiltration cellular, mononuclear cell	1 (2%)		3 (6%)	1 (2%)
Nose	(49)	(50)	(50)	(49)
Inflammation, suppurative	1 (2%)		2 (4%)	
Nasolacrimal duct, inflammation, suppurative	1 (2%)	2 (4%)		1 (2%)
Olfactory epithelium, atrophy	5 (10%)	4 (8%)	5 (10%)	2 (4%)
Olfactory epithelium, metaplasia	4 (8%)	3 (6%)	2 (4%)	1 (2%)
Olfactory epithelium, necrosis		1 (2%)		1 (2%)
Respiratory epithelium, hyperplasia			1 (2%)	
Respiratory epithelium, metaplasia, squamous			1 (2%)	
Respiratory epithelium, necrosis		1 (2%)	1 (2%)	
Trachea	(49)	(49)	(49)	(49)
Metaplasia, squamous			1 (2%)	
<b>Special Senses System</b>				
None				
<b>Urinary System</b>				
Kidney	(49)	(49)	(50)	(48)
Amyloid deposition	1 (2%)	2 (4%)		
Hydronephrosis		1 (2%)		
Hyperplasia, atypical	1 (2%)			
Infarct		1 (2%)		
Infiltration cellular, mononuclear cell		1 (2%)		
Inflammation, suppurative	1 (2%)			
Metaplasia, osseous		3 (6%)	1 (2%)	3 (6%)
Nephropathy	23 (47%)	31 (63%)	26 (52%)	23 (48%)
Arteriole, inflammation, chronic	1 (2%)			
Cortex, cyst	1 (2%)			
Cortex, pigmentation, hemosiderin	1 (2%)	1 (2%)		
Glomerulus, embolus		1 (2%)		
Renal tubule, mineralization		1 (2%)		
Renal tubule, necrosis				2 (4%)
Urinary bladder	(48)	(48)	(50)	(47)
Inflammation, chronic			1 (2%)	
Ulcer	1 (2%)			
Arteriole, inflammation	1 (2%)			
Transitional epithelium, hyperplasia	1 (2%)			



## APPENDIX E

### GENETIC TOXICOLOGY

<i>SALMONELLA</i> MUTAGENICITY TEST PROTOCOL .....	220
CHINESE HAMSTER OVARY CELL CYTOGENETICS PROTOCOLS .....	220
MOUSE PERIPHERAL BLOOD MICRONUCLEUS TEST PROTOCOL .....	221
RESULTS .....	222
TABLE E1 Mutagenicity of Acetonitrile in <i>Salmonella typhimurium</i> .....	223
TABLE E2 Induction of Sister Chromatid Exchanges in Chinese Hamster Ovary Cells by Acetonitrile .....	225
TABLE E3 Induction of Chromosomal Aberrations in Chinese Hamster Ovary Cells by Acetonitrile .....	226
TABLE E4 Frequency of Micronuclei in Mouse Peripheral Blood Erythrocytes Following Treatment with Acetonitrile by Inhalation for 13 Weeks .....	227

## GENETIC TOXICOLOGY

### ***SALMONELLA* MUTAGENICITY TEST PROTOCOL**

Testing was performed as reported by Mortelmans *et al.* (1986). Acetonitrile was sent to two testing laboratories as a coded aliquot from Radian Corporation (Austin, TX). It was incubated with the *Salmonella typhimurium* tester strains (TA97, TA98, TA100, TA1535, and TA1537) either in buffer or S9 mix (metabolic activation enzymes and cofactors from Aroclor 1254-induced male Sprague-Dawley rat or Syrian hamster liver) for 20 minutes at 37° C. Top agar supplemented with *l*-histidine and *d*-biotin was added, and the contents of the tubes were mixed and poured onto the surfaces of minimal glucose agar plates. Histidine-independent mutant colonies arising on these plates were counted following incubation for 2 days at 37° C. All tests were repeated using either the same or different S9 concentrations.

Each trial consisted of triplicate plates of concurrent positive and negative controls and at least five doses of acetonitrile. In the absence of toxicity, 10,000 µg/plate was selected as the high dose. All assays were repeated.

In this assay, a positive response is defined as a reproducible, dose-related increase in histidine-independent (revertant) colonies in any one strain/activation combination. An equivocal response is defined as an increase in revertants that is not dose related, not reproducible, or is of insufficient magnitude to support a determination of mutagenicity. A negative response is obtained when no increase in revertant colonies is observed following chemical treatment. There was no minimum percentage or fold increase required for a chemical to be judged positive or weakly positive.

### **CHINESE HAMSTER OVARY CELL CYTOGENETICS PROTOCOLS**

Testing was performed as reported by Galloway *et al.* (1987). Acetonitrile was sent to the laboratory as a coded aliquot by Radian Corporation. It was tested in cultured Chinese hamster ovary (CHO) cells for induction of sister chromatid exchanges (SCEs) and chromosomal aberrations (Abs), both in the presence and absence of Aroclor 1254-induced male Sprague-Dawley rat liver S9 and cofactor mix. Cultures were handled under gold lights to prevent photolysis of bromodeoxyuridine-substituted DNA. Each test consisted of concurrent solvent and positive controls and of at least three doses of acetonitrile. In the absence of toxicity, 5,000 µg/mL was selected as the high dose. A single flask per dose was used, and tests yielding equivocal or positive results were repeated.

***Sister Chromatid Exchange Test:*** In the SCE test without S9, CHO cells were incubated for 26 hours with acetonitrile in supplemented McCoy's 5A medium. Bromodeoxyuridine (BrdU) was added 2 hours after culture initiation. After 26 hours, the medium containing acetonitrile was removed and replaced with fresh medium plus BrdU and Colcemid, and incubation was continued for 2 hours. Cells were then harvested by mitotic shake-off, fixed, and stained with Hoechst 33258 and Giemsa. In the SCE test with S9, cells were incubated with acetonitrile, serum-free medium, and S9 for 2 hours. The medium was then removed and replaced with medium containing serum and BrdU and no acetonitrile, and incubation proceeded for an additional 26 hours, with Colcemid present for the final 2 hours. Harvesting and staining were the same as for cells treated without S9. All slides were scored blind and those from a single test were read by the same person. Fifty second-division metaphase cells were scored for frequency of SCEs/cell from each dose level.

Statistical analyses were conducted on the slopes of the dose-response curves and the individual dose points (Galloway *et al.*, 1987). An SCE frequency 20% above the concurrent solvent control value was chosen as a statistically conservative positive response. The probability of this level of difference occurring by chance at one dose point is less than 0.01; the probability for such a chance occurrence at two dose



points is less than 0.001. An increase of 20% or greater at any single dose was considered weak evidence of activity; increases at two or more doses resulted in a determination that the trial was positive. A statistically significant trend ( $P < 0.005$ ) in the absence of any responses reaching 20% above background led to a call of equivocal.

**Chromosomal Aberrations Test:** In the Abs test without S9, cells were incubated in McCoy's 5A medium with acetonitrile for 12 hours; Colcemid was added and incubation continued for 2 hours. The cells were then harvested by mitotic shake-off, fixed, and stained with Giemsa. For the Abs test with S9, cells were treated with acetonitrile and S9 for 2 hours, after which the treatment medium was removed and the cells were incubated for 12 hours in fresh medium, with Colcemid present for the final 2 hours. Cells were harvested in the same manner as for the treatment without S9.

Cells were selected for scoring on the basis of good morphology and completeness of karyotype ( $21 \pm 2$  chromosomes). All slides were scored blind and those from a single test were read by the same person. One hundred first-division metaphase cells were scored at each dose level. Classes of aberrations included simple (breaks and terminal deletions), complex (rearrangements and translocations), and other (pulverized cells, despiralized chromosomes, and cells containing 10 or more aberrations).

Chromosomal aberration data are presented as percentage of cells with aberrations. To arrive at a statistical call for a trial, analyses were conducted on both the dose response curve and individual dose points. For a single trial, a statistically significant ( $P \leq 0.05$ ) difference for one dose point and a significant trend ( $P \leq 0.015$ ) were considered weak evidence for a positive response; significant differences for two or more doses indicated the trial was positive. A positive trend test in the absence of a statistically significant increase at any one dose resulted in an equivocal call (Galloway *et al.*, 1987). Ultimately, the trial calls were based on a consideration of the statistical analyses as well as the biological information available to the reviewers.

## MOUSE PERIPHERAL BLOOD MICRONUCLEUS TEST PROTOCOL

A detailed discussion of this assay can be found in MacGregor *et al.* (1990). Peripheral blood samples were obtained from male and female B6C3F<sub>1</sub> mice at the end of the 13-week toxicity study. Smears were immediately prepared and fixed in absolute methanol, stained with a chromatin-specific fluorescent dye mixture of Hoechst 33258/pyronin Y (MacGregor *et al.*, 1983), and coded. Slides were scanned at 630 or 1,000 times magnification using a semi-automated image analysis system to determine the frequency of micronuclei in 10,000 normochromatic erythrocytes (NCEs) in each of 10 animals per dose group. The criteria of Schmid (1976) were used to define micronuclei, with the additional requirement that the micronuclei exhibit the characteristic fluorescent emissions of DNA (blue with 360 nm and orange with 510 nm illumination); the minimum size limit was approximately one-twentieth the diameter of the NCE cell. The results were tabulated as the mean of the pooled results from all animals within a treatment group, plus or minus the standard error of the mean. The frequency of micronucleated cells among NCEs was analyzed by a statistical software package that tested for increasing trend over exposure groups using a one-tailed Cochran-Armitage trend test, followed by pairwise comparisons between each exposure group and the control group (Margolin *et al.*, 1990). In the presence of excess binomial variation, as detected by a binomial dispersion test, the binomial variance of the Cochran-Armitage test was adjusted upward in proportion to the excess variation. In the micronucleus test, an individual trial is considered positive if 1) the trend test P value is  $\leq 0.025$  or 2) the P value for any single exposure group is  $\leq 0.025/N$  where  $N$  = the number of exposure groups. A final call of positive for micronucleus induction is preferably based on reproducibly positive trials (as noted previously). Ultimately, the final call is determined by the scientific staff after considering the results of statistical analyses, reproducibility of any effects observed, and the magnitudes of those effects.

## RESULTS

Acetonitrile (100 to 10,000  $\mu\text{g}/\text{plate}$ ) was tested in two laboratories for induction of mutations in *S. typhimurium* strains TA97, TA98, TA100, TA1535, and TA1537, with and without Aroclor 1254-induced rat and hamster liver S9; no mutagenic activity was observed in any strain/activation combination (Mortelmans *et al.*, 1986; Table E1). In cytogenetic tests with CHO cells, acetonitrile was a weak inducer of SCEs in the absence of S9 (Galloway *et al.*, 1987; Table E2) and Abs in the presence of S9 (Galloway *et al.*, 1987; Table E3); for both endpoints, the increases were noted at the highest dose tested (5,000  $\mu\text{g}/\text{mL}$ ). Despite the increase in Abs noted at the high dose in the trial conducted with S9, the trend test was not significant ( $P > 0.015$ ) and the trial results were concluded to be equivocal.

The ability of acetonitrile to induce chromosomal damage in mammalian cells *in vivo* was assessed by determining the frequency of micronucleated NCEs in peripheral blood samples of male and female mice treated for 13 weeks with acetonitrile (100 to 800 ppm) by inhalation (Table E4). Results with female mice were negative, but in males, a small but significant increase in micronucleated NCEs was observed in the 400 ppm group.

In conclusion, acetonitrile did not induce gene mutations in bacteria and showed only weak clastogenic activity in cultured mammalian cells; *in vivo*, evidence for chromosomal damage in male mice was observed in the form of increased frequencies of micronucleated NCEs.

**TABLE E1**  
**Mutagenicity of Acetonitrile in *Salmonella typhimurium*<sup>a</sup>**

Strain	Dose ( $\mu\text{g}/\text{plate}$ )	Revertants/plate <sup>b</sup>		
		-S9	+10% hamster S9	+10% rat S9
<b>Study performed at SRI, International</b>				
<b>TA100</b>				
	0	159 $\pm$ 7.4	155 $\pm$ 2.9	158 $\pm$ 4.1
	100	178 $\pm$ 2.7	174 $\pm$ 9.0	134 $\pm$ 10.6
	333	171 $\pm$ 6.0	172 $\pm$ 7.5	140 $\pm$ 12.1
	1,000	157 $\pm$ 7.9	171 $\pm$ 9.2	135 $\pm$ 2.6
	3,333	159 $\pm$ 8.5	166 $\pm$ 9.2	136 $\pm$ 2.9
	10,000	174 $\pm$ 3.5	162 $\pm$ 7.0	126 $\pm$ 5.5
Trial summary		Negative	Negative	Negative
Positive control <sup>c</sup>		471 $\pm$ 17.5	1,584 $\pm$ 55.1	1,262 $\pm$ 54.6
<b>TA1535</b>				
	0	32 $\pm$ 3.0	15 $\pm$ 3.2	16 $\pm$ 1.5
	100	23 $\pm$ 4.8	17 $\pm$ 2.3	14 $\pm$ 1.2
	333	25 $\pm$ 3.5	17 $\pm$ 0.3	15 $\pm$ 0.9
	1,000	18 $\pm$ 1.2	13 $\pm$ 4.1	14 $\pm$ 4.0
	3,333	24 $\pm$ 2.0	15 $\pm$ 0.7	13 $\pm$ 0.9
	10,000	25 $\pm$ 2.6	22 $\pm$ 2.2	15 $\pm$ 3.5
Trial summary		Negative	Negative	Negative
Positive control		359 $\pm$ 12.5	505 $\pm$ 13.2	438 $\pm$ 30.3
<b>TA1537</b>				
	0	13 $\pm$ 0.7	18 $\pm$ 1.0	16 $\pm$ 1.9
	100	12 $\pm$ 1.7	21 $\pm$ 4.5	16 $\pm$ 2.0
	333	8 $\pm$ 2.6	14 $\pm$ 3.3	15 $\pm$ 2.0
	1,000	10 $\pm$ 2.1	18 $\pm$ 1.8	12 $\pm$ 1.5
	3,333	11 $\pm$ 1.7	21 $\pm$ 6.4	14 $\pm$ 1.3
	10,000	10 $\pm$ 1.7	11 $\pm$ 1.2	16 $\pm$ 2.7
Trial summary		Negative	Negative	Negative
Positive control		215 $\pm$ 8.4	559 $\pm$ 5.5	491 $\pm$ 60.8
<b>TA98</b>				
	0	30 $\pm$ 1.5	42 $\pm$ 1.7	44 $\pm$ 3.7
	100	30 $\pm$ 3.2	44 $\pm$ 3.2	34 $\pm$ 2.9
	333	32 $\pm$ 2.5	47 $\pm$ 0.7	43 $\pm$ 5.8
	1,000	28 $\pm$ 7.5	47 $\pm$ 4.4	38 $\pm$ 3.8
	3,333	32 $\pm$ 3.8	44 $\pm$ 3.7	38 $\pm$ 1.0
	10,000	35 $\pm$ 5.2	44 $\pm$ 2.0	34 $\pm$ 1.2
Trial summary		Negative	Negative	Negative
Positive control		815 $\pm$ 4.9	1,393 $\pm$ 120.7	1,031 $\pm$ 178.1

TABLE E1  
Mutagenicity of Acetonitrile in *Salmonella typhimurium* (continued)

Strain	Dose ( $\mu\text{g}/\text{plate}$ )	Revertants/plate				
		-S9	+hamster S9		+rat S9	
			10%	30%	10%	30%
Study performed at Microbiological Associates, Inc.						
TA100	0	81 $\pm$ 6.2	80 $\pm$ 0.6	91 $\pm$ 1.3	88 $\pm$ 5.2	90 $\pm$ 2.7
	100	83 $\pm$ 6.4	87 $\pm$ 8.8	87 $\pm$ 6.0	82 $\pm$ 7.9	76 $\pm$ 10.0
	333	73 $\pm$ 5.2	94 $\pm$ 3.7	80 $\pm$ 2.7	80 $\pm$ 4.1	84 $\pm$ 4.0
	1,000	84 $\pm$ 4.5	110 $\pm$ 1.5	88 $\pm$ 4.6	85 $\pm$ 2.4	84 $\pm$ 2.9
	3,333	74 $\pm$ 6.2	97 $\pm$ 4.0	99 $\pm$ 4.8	76 $\pm$ 10.0	87 $\pm$ 7.5
	10,000	74 $\pm$ 5.6	91 $\pm$ 4.3	79 $\pm$ 4.3	92 $\pm$ 6.8	84 $\pm$ 4.4
	Trial summary	Negative	Negative	Negative	Negative	Negative
Positive control	204 $\pm$ 3.0	404 $\pm$ 21.5	285 $\pm$ 15.0	282 $\pm$ 44.3	700 $\pm$ 23.7	
TA1535	0	16 $\pm$ 0.6		12 $\pm$ 1.0	12 $\pm$ 1.9	7 $\pm$ 2.3
	100	14 $\pm$ 0.0		8 $\pm$ 1.2	8 $\pm$ 1.3	8 $\pm$ 0.3
	333	14 $\pm$ 3.0		8 $\pm$ 0.7	9 $\pm$ 2.3	9 $\pm$ 3.6
	1,000	14 $\pm$ 3.3		12 $\pm$ 0.9	9 $\pm$ 0.9	12 $\pm$ 1.8
	3,333	15 $\pm$ 1.0		9 $\pm$ 1.3	7 $\pm$ 0.6	10 $\pm$ 1.8
	10,000	13 $\pm$ 0.9		10 $\pm$ 1.0	10 $\pm$ 1.8	9 $\pm$ 2.9
	Trial summary	Negative	Negative	Negative	Negative	Negative
Positive control	89 $\pm$ 2.9		69 $\pm$ 6.2	119 $\pm$ 10.5	109 $\pm$ 2.0	
TA97	0	94 $\pm$ 3.9	108 $\pm$ 4.2	160 $\pm$ 4.3	140 $\pm$ 3.7	195 $\pm$ 6.2
	100	108 $\pm$ 13.4	103 $\pm$ 10.5	167 $\pm$ 9.3	130 $\pm$ 3.3	172 $\pm$ 14.4
	333	96 $\pm$ 3.8	102 $\pm$ 4.3	148 $\pm$ 3.0	141 $\pm$ 6.4	166 $\pm$ 6.9
	1,000	91 $\pm$ 14.2	92 $\pm$ 6.6	165 $\pm$ 6.8	120 $\pm$ 1.0	161 $\pm$ 12.5
	3,333	89 $\pm$ 2.3	90 $\pm$ 3.5	160 $\pm$ 3.8	126 $\pm$ 12.0	168 $\pm$ 14.2
	10,000	80 $\pm$ 4.8	93 $\pm$ 8.0	182 $\pm$ 14.7	121 $\pm$ 10.0	157 $\pm$ 10.9
	Trial summary	Negative	Negative	Negative	Negative	Negative
Positive control	420 $\pm$ 26.1	285 $\pm$ 21.2	291 $\pm$ 4.9	723 $\pm$ 15.7	403 $\pm$ 10.1	
TA98	0	21 $\pm$ 1.9	31 $\pm$ 1.7	35 $\pm$ 1.0	31 $\pm$ 2.4	32 $\pm$ 3.0
	100	21 $\pm$ 3.7	24 $\pm$ 2.1	34 $\pm$ 1.2	23 $\pm$ 1.2	40 $\pm$ 3.7
	333	23 $\pm$ 1.2	27 $\pm$ 2.4	31 $\pm$ 5.3	25 $\pm$ 0.7	29 $\pm$ 1.8
	1,000	20 $\pm$ 0.9	36 $\pm$ 4.1	30 $\pm$ 3.0	21 $\pm$ 4.0	31 $\pm$ 3.5
	3,333	15 $\pm$ 2.0	27 $\pm$ 4.1	33 $\pm$ 1.7	24 $\pm$ 2.3	34 $\pm$ 2.3
	10,000	22 $\pm$ 5.7	30 $\pm$ 2.3	26 $\pm$ 3.6	22 $\pm$ 2.7	37 $\pm$ 1.2
	Trial summary	Negative	Negative	Negative	Negative	Negative
Positive control	113 $\pm$ 5.8	187 $\pm$ 10.1	117 $\pm$ 9.5	160 $\pm$ 12.9	211 $\pm$ 20.8	

<sup>a</sup> The detailed protocol and these data are presented in Mortelmans *et al.* (1986). 0  $\mu\text{g}/\text{plate}$  dose is the solvent control.

<sup>b</sup> Revertants are presented as mean  $\pm$  the standard error from 3 plates.

<sup>c</sup> The positive controls in the absence of metabolic activation were sodium azide (TA100 and TA1535), 9-aminoacridine (TA97 and TA1537), and 4-nitro-*o*-phenylenediamine (TA98). The positive control for metabolic activation with all strains was 2-aminoanthracene.

**TABLE E2**  
**Induction of Sister Chromatid Exchanges in Chinese Hamster Ovary Cells by Acetonitrile<sup>a</sup>**

Compound	Dose ( $\mu\text{g}/\text{mL}$ )	Total Cells	No. of Chromo- somes	No. of SCEs	SCEs/ Chromo- some	SCEs/ Cell	Hrs in BrdU	Relative Change of SCEs/ Chromosome <sup>b</sup> (%)
<b>-S9</b>								
Summary: Weak positive								
Distilled water		50	1,042	383	0.36	7.7	26.0	
Triethylenemelamine	0.015	50	1,050	1,442	1.37	28.8	26.0	273.63
Acetonitrile	160	50	1,049	440	0.41	8.8	26.0	14.11
	500	50	1,043	428	0.41	8.6	26.0	11.64
	1,600	50	1,050	459	0.43	9.2	26.0	18.93
	5,000	50	1,049	469	0.44	9.4	26.0	21.64*
					P=0.003 <sup>c</sup>			
<b>+S9</b>								
Summary: Negative								
Distilled water		50	1,042	408	0.39	8.2	26.0	
Cyclophosphamide	1.000	50	1,046	910	0.86	18.2	26.0	122.19
Acetonitrile	500	50	1,039	431	0.41	8.6	26.0	5.94
	1,600	50	1,039	392	0.37	7.8	26.0	-3.65
	5,000	50	1,037	414	0.39	8.3	26.0	1.96
					P=0.568			

\* Positive ( $P < 0.01$ )

<sup>a</sup> Study performed at Columbia University. A detailed description of the protocol and these data are presented in Galloway *et al.* (1987). SCE=sister chromatid exchange; BrdU=bromodeoxyuridine

<sup>b</sup> SCEs/chromosome in treated cells versus SCEs/chromosome in solvent control cells.

<sup>c</sup> Significance of relative SCEs/chromosome tested by the linear regression trend test vs. log of the dose

**TABLE E3**  
**Induction of Chromosomal Aberrations in Chinese Hamster Ovary Cells by Acetonitrile<sup>a</sup>**

-S9					+S9				
Dose ( $\mu\text{g/mL}$ )	Total Cells	No. of Abs	Abs/ Cell	Cells with Abs (%)	Dose ( $\mu\text{g/mL}$ )	Total Cells	No. of Abs	Abs/ Cell	Cells with Abs (%)
Harvest time: 14.0 Summary: Negative					Harvest time: 14.0 Summary: Equivocal				
Distilled water					Distilled water				
	100	2	0.02	2.0		100	1	0.01	1.0
Triethylenemelamine					Cyclophosphamide				
0.15	50	14	0.28	20.0	15.0	50	27	0.54	44.0
Acetonitrile					Acetonitrile				
500	100	2	0.02	2.0	500	100	3	0.03	3.0
1,600	100	9	0.09	7.0	1,600	100	2	0.02	2.0*
5,000	100	5	0.05	5.0	5,000	100	8	0.08	7.0*
P=0.054 <sup>b</sup>					P=0.016				

\* Positive ( $P < 0.05$ )

<sup>a</sup> Study performed at Columbia University. The detailed protocol and these data are presented in Galloway *et al.* (1987).  
 Abs=aberrations.

<sup>b</sup> Significance of percent cells with aberrations tested by the linear regression trend test vs. log of the dose

**TABLE E4**  
**Frequency of Micronuclei in Mouse Peripheral Blood Erythrocytes Following Treatment with Acetonitrile by Inhalation for 13 Weeks<sup>a</sup>**

Dose (ppm)	Micronucleated Normochromatic Erythrocytes/1,000 Cells <sup>b</sup>	Number of Mice
<b>Male</b>		
0	1.42 ± 0.13	10
100	1.91 ± 0.11	10
200	1.71 ± 0.10	10
400	2.36 ± 0.29*	10
800	2.06 ± 0.28	10
Trend test	P=0.007 <sup>c</sup>	
<b>Female</b>		
0	1.33 ± 0.12	10
100	1.16 ± 0.16	10
200	1.61 ± 0.16	10
400	1.71 ± 0.15	9
800	1.57 ± 0.15	6
Trend test	P=0.03	

\* Positive ( $P < 0.006$ ) by pairwise comparison to the control group with a *t*-test.

<sup>a</sup> Peripheral blood samples obtained at termination of the 13-week toxicity study. A detailed protocol is presented in MacGregor *et al.* (1990); a minimum of 10,000 NCEs were scored per animal.

<sup>b</sup> Data presented as mean ± standard error of the mean. NCE = normochromatic erythrocyte.

<sup>c</sup> Significance of micronucleated NCEs/1,000 NCEs tested by a one-tailed Cochran-Armitage trend test.





## APPENDIX F ORGAN WEIGHTS AND ORGAN-WEIGHT-TO-BODY-WEIGHT RATIOS

<b>TABLE F1</b>	<b>Organ Weights and Organ-Weight-to-Body-Weight Ratios for Rats in the 13-Week Inhalation Study of Acetonitrile . . . . .</b>	<b>230</b>
<b>TABLE F2</b>	<b>Organ Weights and Organ-Weight-to-Body-Weight Ratios for Rats at the 15-Month Interim Evaluation in the 2-Year Inhalation Study of Acetonitrile . . . . .</b>	<b>232</b>
<b>TABLE F3</b>	<b>Organ Weights and Organ-Weight-to-Body-Weight Ratios for Mice in the 13-Week Inhalation Study of Acetonitrile . . . . .</b>	<b>233</b>
<b>TABLE F4</b>	<b>Organ Weights and Organ-Weight-to-Body-Weight Ratios for Mice at the 15-Month Interim Evaluation in the 2-Year Inhalation Study of Acetonitrile . . . . .</b>	<b>235</b>

**TABLE F1**  
**Organ Weights and Organ-Weight-to-Body-Weight Ratios for Rats in the 13-Week Inhalation Study of Acetonitrile<sup>a</sup>**

	0 ppm	100 ppm	200 ppm	400 ppm	800 ppm	1,600 ppm
<b>Male</b>						
n	10	10	10	10	9	4
Necropsy body wt	345 ± 4	354 ± 5	364 ± 6	348 ± 5	349 ± 7	285 ± 12**
<b>Brain</b>						
Absolute	1.886 ± 0.014	1.898 ± 0.011	1.923 ± 0.013	1.867 ± 0.021	1.876 ± 0.013	1.793 ± 0.017**
Relative	5.48 ± 0.09	5.38 ± 0.06	5.29 ± 0.08	5.38 ± 0.10	5.39 ± 0.10	6.32 ± 0.26**
<b>Heart</b>						
Absolute	0.920 ± 0.018	1.022 ± 0.070	0.969 ± 0.015	0.948 ± 0.013	0.963 ± 0.020	0.940 ± 0.049
Relative	2.67 ± 0.04	2.90 ± 0.22	2.66 ± 0.02	2.73 ± 0.04	2.77 ± 0.04	3.30 ± 0.10**
<b>L. and R. Kidney</b>						
Absolute	2.279 ± 0.016	2.357 ± 0.049	2.446 ± 0.039*	2.312 ± 0.028	2.396 ± 0.060	2.303 ± 0.146
Relative	6.62 ± 0.07	6.67 ± 0.09	6.72 ± 0.09	6.65 ± 0.07	6.87 ± 0.08*	8.06 ± 0.20**
<b>Liver</b>						
Absolute	11.800 ± 0.195	12.565 ± 0.454	12.775 ± 0.238	12.011 ± 0.214	12.468 ± 0.345	11.803 ± 0.758
Relative	34.23 ± 0.39	35.57 ± 1.33	35.10 ± 0.45	34.52 ± 0.28	35.74 ± 0.57	41.41 ± 1.76**
<b>Lungs</b>						
Absolute	1.937 ± 0.048	1.983 ± 0.089	2.200 ± 0.094	1.972 ± 0.086	1.998 ± 0.083	1.800 ± 0.158
Relative	5.62 ± 0.12	5.59 ± 0.19	6.04 ± 0.23	5.67 ± 0.24	5.73 ± 0.22	6.30 ± 0.36
<b>R. Testis</b>						
Absolute	1.331 ± 0.035	1.364 ± 0.022	1.355 ± 0.021	1.291 ± 0.017	1.283 ± 0.018	1.063 ± 0.028**
Relative	3.86 ± 0.09	3.86 ± 0.07	3.73 ± 0.06	3.72 ± 0.05	3.69 ± 0.06	3.75 ± 0.20
<b>Thymus</b>						
Absolute	0.281 ± 0.010	0.261 ± 0.022	0.287 ± 0.017	0.274 ± 0.012	0.228 ± 0.014*	0.130 ± 0.008**
Relative	0.81 ± 0.03	0.74 ± 0.06	0.79 ± 0.04	0.79 ± 0.03	0.65 ± 0.03**	0.46 ± 0.03**

**TABLE F1**  
**Organ Weights and Organ-Weight-to-Body-Weight Ratios for Rats in the 13-Week Inhalation Study of Acetonitrile**  
 (continued)

	0 ppm	100 ppm	200 ppm	400 ppm	800 ppm	1,600 ppm
<b>Female</b>						
n	10	10	10	10	10	7
Necropsy body wt	201 ± 4	194 ± 4	206 ± 3	214 ± 4	206 ± 3	183 ± 4**
<b>Brain</b>						
Absolute	1.755 ± 0.011	1.758 ± 0.014	1.756 ± 0.014	1.745 ± 0.020	1.742 ± 0.008	1.703 ± 0.011
Relative	8.77 ± 0.16	9.12 ± 0.20	8.56 ± 0.09	8.17 ± 0.10*	8.46 ± 0.11	9.35 ± 0.19*
<b>Heart</b>						
Absolute	0.613 ± 0.015	0.625 ± 0.014	0.681 ± 0.012*	0.663 ± 0.011*	0.671 ± 0.022*	0.769 ± 0.026**
Relative	3.05 ± 0.06	3.23 ± 0.05	3.32 ± 0.07	3.10 ± 0.04	3.25 ± 0.07	4.22 ± 0.15**
<b>L. and R. Kidney</b>						
Absolute	1.370 ± 0.031	1.395 ± 0.028	1.449 ± 0.024	1.496 ± 0.030**	1.486 ± 0.025**	1.514 ± 0.039**
Relative	6.82 ± 0.08	7.22 ± 0.12*	7.06 ± 0.09	7.00 ± 0.08	7.21 ± 0.07**	8.30 ± 0.14**
<b>Liver</b>						
Absolute	6.313 ± 0.173	6.328 ± 0.116	6.618 ± 0.235	6.861 ± 0.228	6.930 ± 0.151*	7.709 ± 0.371**
Relative	31.53 ± 1.00	32.78 ± 0.72	32.19 ± 0.96	32.04 ± 0.73	33.64 ± 0.77	42.44 ± 2.56**
<b>Lungs</b>						
Absolute	1.227 ± 0.023	1.269 ± 0.025	1.284 ± 0.032	1.362 ± 0.043*	1.272 ± 0.037	1.189 ± 0.024
Relative	6.11 ± 0.06	6.56 ± 0.10*	6.25 ± 0.12	6.36 ± 0.14	6.16 ± 0.14	6.52 ± 0.14
<b>Thymus</b>						
Absolute	0.235 ± 0.007	0.212 ± 0.006	0.226 ± 0.008	0.243 ± 0.007	0.203 ± 0.006**	0.118 ± 0.010**
Relative	1.17 ± 0.03	1.10 ± 0.02	1.10 ± 0.03	1.13 ± 0.02	0.98 ± 0.03**	0.64 ± 0.04**

\* Significantly different ( $P \leq 0.05$ ) from the control group by Williams' or Dunnett's test

\*\*  $P \leq 0.01$

<sup>a</sup> Organ weights and body weights are given in grams; organ-weight-to-body-weight ratios are given as mg organ weight/g body weight (mean ± standard error).

**TABLE F2**  
**Organ Weights and Organ-Weight-to-Body-Weight Ratios for Rats at the 15-Month Interim Evaluation**  
**in the 2-Year Inhalation Study of Acetonitrile<sup>a</sup>**

	0 ppm	100 ppm	200 ppm	400 ppm
n	8	8	8	8
<b>Male</b>				
Necropsy body wt	507 ± 11	500 ± 7	489 ± 5	482 ± 7
R. Kidney				
Absolute	1.640 ± 0.035	1.590 ± 0.035	1.595 ± 0.028	1.565 ± 0.030
Relative	3.24 ± 0.06	3.18 ± 0.06	3.26 ± 0.05	3.25 ± 0.06
Liver				
Absolute	16.805 ± 0.639	15.845 ± 0.349	15.961 ± 0.310	15.573 ± 0.321
Relative	33.10 ± 0.72	31.68 ± 0.63	32.60 ± 0.47	32.31 ± 0.35
Lungs				
Absolute	2.203 ± 0.066	2.314 ± 0.065	2.281 ± 0.152	2.150 ± 0.032
Relative	4.35 ± 0.13	4.63 ± 0.12	4.65 ± 0.28	4.47 ± 0.07
<b>Female</b>				
Necropsy body wt	307 ± 13	311 ± 7	308 ± 7	320 ± 8
R. Kidney				
Absolute	0.989 ± 0.031	0.996 ± 0.040	1.003 ± 0.017	1.033 ± 0.028
Relative	3.24 ± 0.11	3.21 ± 0.13	3.26 ± 0.07	3.24 ± 0.12
Liver				
Absolute	9.026 ± 0.380	9.601 ± 0.359	9.464 ± 0.380	9.630 ± 0.364
Relative	29.47 ± 0.68	30.98 ± 1.36	30.66 ± 0.77	30.02 ± 0.67
Lungs				
Absolute	1.569 ± 0.047	1.701 ± 0.144	1.665 ± 0.075	1.543 ± 0.042
Relative	5.14 ± 0.12	5.49 ± 0.50	5.41 ± 0.26	4.83 ± 0.14

<sup>a</sup> Organ weights and body weights are given in grams; organ-weight-to-body-weight ratios are given as mg organ weight/g body weight (mean ± standard error).

**TABLE F3**  
**Organ Weights and Organ-Weight-to-Body-Weight Ratios for Mice in the 13-Week Inhalation Study of Acetonitrile<sup>a</sup>**

	0 ppm	100 ppm	200 ppm	400 ppm	800 ppm	1,600 ppm
<b>Male</b>						
n	10	10	10	10	9	0
Necropsy body wt	35.6 ± 0.6	34.1 ± 0.6	34.8 ± 0.5	34.3 ± 0.8	33.7 ± 0.3	— <sup>b</sup>
<b>Brain</b>						
Absolute	0.461 ± 0.005	0.459 ± 0.005	0.475 ± 0.004	0.469 ± 0.002	0.456 ± 0.003	—
Relative	13.00 ± 0.25	13.51 ± 0.27	13.67 ± 0.19	13.71 ± 0.28	13.52 ± 0.11	—
<b>Heart</b>						
Absolute	0.160 ± 0.006	0.156 ± 0.004	0.156 ± 0.003	0.155 ± 0.005	0.156 ± 0.006	—
Relative	4.49 ± 0.11	4.59 ± 0.12	4.49 ± 0.09	4.52 ± 0.13	4.62 ± 0.19	—
<b>L. and R. Kidney</b>						
Absolute	0.599 ± 0.017	0.634 ± 0.010	0.646 ± 0.007*	0.636 ± 0.014	0.599 ± 0.014	—
Relative	16.87 ± 0.46	18.64 ± 0.35**	18.58 ± 0.25**	18.53 ± 0.17**	17.76 ± 0.37	—
<b>Liver</b>						
Absolute	1.665 ± 0.044	1.758 ± 0.034	1.822 ± 0.030*	1.945 ± 0.059**	2.111 ± 0.047**	—
Relative	46.79 ± 0.76	51.62 ± 0.61**	52.37 ± 0.75**	56.56 ± 0.60**	62.59 ± 1.17**	—
<b>Lungs</b>						
Absolute	0.236 ± 0.007	0.243 ± 0.005	0.257 ± 0.006	0.247 ± 0.007	0.249 ± 0.006	—
Relative	6.65 ± 0.23	7.13 ± 0.07*	7.38 ± 0.10**	7.20 ± 0.15**	7.38 ± 0.14**	—
<b>R. Testis</b>						
Absolute	0.119 ± 0.002	0.120 ± 0.001	0.122 ± 0.002	0.118 ± 0.002	0.115 ± 0.002	—
Relative	3.35 ± 0.10	3.52 ± 0.06	3.51 ± 0.05	3.45 ± 0.08	3.40 ± 0.06	—
<b>Thymus</b>						
Absolute	0.030 ± 0.002	0.034 ± 0.002	0.035 ± 0.001	0.032 ± 0.002	0.028 ± 0.003	—
Relative	0.85 ± 0.06	1.01 ± 0.04	0.99 ± 0.03	0.94 ± 0.05	0.83 ± 0.08	—

**TABLE F3**  
**Organ Weights and Organ-Weight-to-Body-Weight Ratios for Mice in the 13-Week Inhalation Study of Acetonitrile**  
 (continued)

	0 ppm	100 ppm	200 ppm	400 ppm	800 ppm	1,600 ppm
<b>Female</b>						
n	10	10 <sup>a</sup>	10	9	6	0
Necropsy body wt	30.5 ± 0.9	30.6 ± 0.9	29.1 ± 0.6	29.4 ± 0.6	31.5 ± 1.1	—
Brain						
Absolute	0.479 ± 0.004	0.481 ± 0.005	0.484 ± 0.005	0.480 ± 0.002	0.475 ± 0.004	—
Relative	15.84 ± 0.44	15.82 ± 0.38	16.67 ± 0.29	16.36 ± 0.35	15.18 ± 0.54	—
Heart						
Absolute	0.143 ± 0.003	0.142 ± 0.002	0.138 ± 0.003	0.138 ± 0.003	0.145 ± 0.004	—
Relative	4.73 ± 0.15	4.67 ± 0.12	4.75 ± 0.10	4.69 ± 0.11	4.62 ± 0.14	—
L. and R. Kidney						
Absolute	0.432 ± 0.011	0.424 ± 0.007	0.424 ± 0.008	0.427 ± 0.002	0.450 ± 0.014	—
Relative	14.23 ± 0.29	13.93 ± 0.31	14.57 ± 0.16	14.53 ± 0.27	14.31 ± 0.13	—
Liver						
Absolute	1.582 ± 0.074	1.616 ± 0.037	1.601 ± 0.032	1.726 ± 0.035	2.057 ± 0.080**	—
Relative	51.95 ± 1.95	52.97 ± 0.92	55.00 ± 0.52	58.65 ± 0.85**	65.31 ± 0.95**	—
Lungs						
Absolute	0.240 ± 0.007	0.244 ± 0.007	0.239 ± 0.006	0.240 ± 0.007	0.238 ± 0.011	—
Relative	7.88 ± 0.11	8.00 ± 0.19	8.21 ± 0.15	8.16 ± 0.20	7.57 ± 0.20	—
Thymus						
Absolute	0.046 ± 0.002	0.050 ± 0.002	0.046 ± 0.003	0.044 ± 0.003	0.046 ± 0.003	—
Relative	1.51 ± 0.09	1.65 ± 0.06	1.58 ± 0.09	1.51 ± 0.11	1.48 ± 0.11	—

\* Significantly different (P≤0.05) from the control group by Williams' or Dunnett's test

\*\* P≤0.01

<sup>a</sup> Organ weights and body weights are given in grams; organ-weight-to-body-weight ratios are given as mg organ weight/g body weight (mean ± standard error).

<sup>b</sup> No data presented due to 100% mortality in this group

**TABLE F4**  
**Organ Weights and Organ-Weight-to-Body-Weight Ratios for Mice at the 15-Month Interim Evaluation in the 2-Year Inhalation Study of Acetonitrile<sup>a</sup>**

	0 ppm	50 ppm	100 ppm	200 ppm
<b>Male</b>				
n	10	10	9	10
Necropsy body wt	47.7 ± 1.6	47.4 ± 1.3	49.0 ± 1.1	49.2 ± 1.2
R. Kidney				
Absolute	0.433 ± 0.009	0.427 ± 0.009	0.434 ± 0.016	0.420 ± 0.013
Relative	9.19 ± 0.40	9.06 ± 0.30	8.85 ± 0.21	8.55 ± 0.18
Liver				
Absolute	2.287 ± 0.183	2.515 ± 0.260	2.188 ± 0.135	2.229 ± 0.097
Relative	48.34 ± 4.34	54.53 ± 7.72	44.51 ± 2.60	45.23 ± 1.18
Lungs				
Absolute	0.253 ± 0.008	0.258 ± 0.007	0.269 ± 0.010	0.258 ± 0.011
Relative	5.33 ± 0.16	5.48 ± 0.21	5.50 ± 0.23	5.25 ± 0.19
<b>Female</b>				
n	10	10	10	10
Necropsy body wt	49.7 ± 1.4	47.4 ± 2.5	51.5 ± 2.6	48.3 ± 2.3
R. Kidney				
Absolute	0.300 ± 0.008	0.271 ± 0.004*	0.302 ± 0.008	0.291 ± 0.007
Relative	6.07 ± 0.17	5.84 ± 0.28	5.93 ± 0.17	6.11 ± 0.23
Liver				
Absolute	1.985 ± 0.052	1.864 ± 0.036	2.095 ± 0.069	2.109 ± 0.045
Relative	40.18 ± 1.23	40.05 ± 1.58	41.13 ± 1.26	44.31 ± 1.62
Lungs				
Absolute	0.257 ± 0.006	0.238 ± 0.007	0.252 ± 0.006	0.267 ± 0.010
Relative	5.21 ± 0.18	5.13 ± 0.26	4.98 ± 0.21	5.65 ± 0.34

\* Significantly different ( $P \leq 0.05$ ) from the control group by Williams' or Dunnett's test

<sup>a</sup> Organ weights and body weights are given in grams; organ-weight-to-body-weight ratios are given as mg organ weight/g body weight (mean ± standard error).





## APPENDIX G HEMATOLOGY AND THYROID HORMONE ASSAY RESULTS

<b>TABLE G1</b>	<b>Hematology and Thyroid Hormone Assay Data for Rats in the 13-Week Inhalation Study of Acetonitrile . . . . .</b>	<b>238</b>
<b>TABLE G2</b>	<b>Hematology Data for Rats at the 15-Month Interim Evaluation in the 2-Year Inhalation Study of Acetonitrile . . . . .</b>	<b>240</b>

**TABLE G1**  
**Hematology and Thyroid Hormone Assay Data for Rats in the 13-Week Inhalation Study of Acetonitrile<sup>a</sup>**

	0 ppm	100 ppm	200 ppm	400 ppm	800 ppm	1,600 ppm
<b>Male</b>						
n	10	10	10	10	9	4
<b>Hematology</b>						
Hematocrit (mL/dL)	46.7 ± 0.5	45.0 ± 0.5	45.9 ± 0.4	46.3 ± 0.2	45.2 ± 0.5	40.7 ± 1.7**
Hemoglobin (g/dL)	15.6 ± 0.2	15.1 ± 0.2	15.3 ± 0.1	15.5 ± 0.1	15.2 ± 0.2	13.4 ± 0.7**
Erythrocytes (10 <sup>6</sup> /μL)	9.41 ± 0.09	9.25 ± 0.11	9.41 ± 0.06	9.61 ± 0.05	9.32 ± 0.09	8.05 ± 0.33*
Mean cell volume (fL)	49.6 ± 0.2	48.7 ± 0.2	48.8 ± 0.2	48.1 ± 0.2**	48.3 ± 0.3**	50.8 ± 0.5
Mean cell hemoglobin (pg)	16.6 ± 0.1	16.4 ± 0.1	16.3 ± 0.0**	16.2 ± 0.1**	16.3 ± 0.1	16.7 ± 0.2
Mean cell hemoglobin concentration (g/dL)	33.4 ± 0.1	33.6 ± 0.1	33.3 ± 0.1	33.6 ± 0.1	33.6 ± 0.1	33.0 ± 0.2
Platelets (10 <sup>3</sup> /μL)	536.6 ± 5.6	572.8 ± 26.4	541.1 ± 8.2	534.3 ± 8.3	533.6 ± 12.6	502.3 ± 12.5
Reticulocytes (10 <sup>6</sup> /μL)	0.1 ± 0.0	0.1 ± 0.0	0.1 ± 0.0	0.1 ± 0.0	0.1 ± 0.0	0.2 ± 0.1
Leukocytes (10 <sup>3</sup> /μL)	5.89 ± 1.00	6.50 ± 0.27	6.40 ± 0.15	5.70 ± 0.23	5.52 ± 0.19	5.20 ± 0.95
<b>Segmented</b>						
neutrophils (10 <sup>3</sup> /μL)	0.85 ± 0.07	1.27 ± 0.22	1.05 ± 0.16	1.01 ± 0.12	0.79 ± 0.11	0.89 ± 0.16
lymphocytes (10 <sup>3</sup> /μL)	4.89 ± 0.30	5.02 ± 0.29	5.08 ± 0.22	4.46 ± 0.17	4.46 ± 0.23	4.22 ± 0.93
monocytes (10 <sup>3</sup> /μL)	0.12 ± 0.02	0.17 ± 0.06	0.24 ± 0.04	0.18 ± 0.04	0.23 ± 0.02	0.06 ± 0.03
eosinophils (10 <sup>3</sup> /μL)	0.06 ± 0.02	0.04 ± 0.01	0.03 ± 0.01	0.05 ± 0.02	0.04 ± 0.02	0.03 ± 0.01
<b>Thyroid Hormone Assays</b>						
Thyroid-stimulating hormone (ng/mL)	1 ± 0	2 ± 0 <sup>b</sup>	1 ± 0	2 ± 0	2 ± 1	2 ± 0
Triiodothyronine (ng/dL)	119 ± 9	126 ± 8 <sup>b</sup>	106 ± 6	98 ± 10	102 ± 8	95 ± 8
Thyroxine (μg/dL)	5 ± 0	5 ± 1 <sup>b</sup>	5 ± 0	4 ± 0	5 ± 1	4 ± 0
<b>Female</b>						
n	10	10	10	10	10	7
<b>Hematology</b>						
Hematocrit (mL/dL)	46.4 ± 0.3	46.2 ± 0.5	46.1 ± 0.5	45.7 ± 0.4	44.7 ± 0.5*	42.0 ± 0.2**
Hemoglobin (g/dL)	15.5 ± 0.1	15.4 ± 0.1	15.4 ± 0.2	15.4 ± 0.1	14.9 ± 0.2*	14.0 ± 0.1**
Erythrocytes (10 <sup>6</sup> /μL)	8.65 ± 0.07	8.62 ± 0.09	8.64 ± 0.09	8.67 ± 0.08	8.25 ± 0.10*	7.91 ± 0.05**
Mean cell volume (fL)	53.8 ± 0.2	53.5 ± 0.2	53.2 ± 0.3	52.4 ± 0.2**	54.3 ± 0.2	53.1 ± 0.3
Mean cell hemoglobin (pg)	17.9 ± 0.1	17.9 ± 0.1	17.9 ± 0.1	17.8 ± 0.1	18.1 ± 0.1	17.8 ± 0.1
Mean cell hemoglobin concentration (g/dL)	33.5 ± 0.1	33.3 ± 0.1	33.5 ± 0.1	33.8 ± 0.2	33.3 ± 0.1	33.5 ± 0.2
Platelets (10 <sup>3</sup> /μL)	594.0 ± 16.8	542.1 ± 21.9	513.3 ± 20.5	534.7 ± 12.8	623.5 ± 25.4	598.4 ± 15.0
Reticulocytes (10 <sup>6</sup> /μL)	0.1 ± 0.0	0.1 ± 0.0	0.1 ± 0.0	0.1 ± 0.0	0.1 ± 0.0	0.1 ± 0.0
Leukocytes (10 <sup>3</sup> /μL)	5.49 ± 0.76	5.69 ± 0.45	6.83 ± 0.50	6.00 ± 0.41	5.24 ± 0.36	3.94 ± 0.29*
<b>Segmented</b>						
neutrophils (10 <sup>3</sup> /μL)	1.20 ± 0.19	1.08 ± 0.22	1.34 ± 0.17	1.04 ± 0.10	1.05 ± 0.18	0.67 ± 0.10
lymphocytes (10 <sup>3</sup> /μL)	4.17 ± 0.15	4.37 ± 0.26	5.20 ± 0.36	4.71 ± 0.39	3.93 ± 0.19	3.20 ± 0.24
monocytes (10 <sup>3</sup> /μL)	0.14 ± 0.03	0.20 ± 0.04	0.23 ± 0.06	0.22 ± 0.06	0.17 ± 0.05	0.08 ± 0.03
eosinophils (10 <sup>3</sup> /μL)	0.03 ± 0.01	0.04 ± 0.01	0.06 ± 0.02	0.03 ± 0.02	0.09 ± 0.02	0.00 ± 0.00

**TABLE G1**  
**Hematology and Thyroid Hormone Assay Data for Rats in the 13-Week Inhalation Study of Acetonitrile (continued)**

	0 ppm	100 ppm	200 ppm	400 ppm	800 ppm	1,600 ppm
<b>Female (continued)</b>						
n	10	10	10	10	10	7
<b>Thyroid Hormone Assays</b>						
Thyroid-stimulating hormone (ng/mL)	1 ± 0	1 ± 0 <sup>b</sup>	1 ± 0	1 ± 0	1 ± 0	1 ± 0
Triiodothyronine (ng/dL)	126 ± 7	114 ± 11 <sup>b</sup>	112 ± 6	122 ± 5	104 ± 6	80 ± 3 <sup>**</sup>
Thyroxine (μg/dL)	4 ± 0	4 ± 0 <sup>b</sup>	4 ± 0	4 ± 0	4 ± 0	3 ± 0

\* Significantly different ( $P \leq 0.05$ ) from the control group by Dunn's or Shirley's test

\*\*  $P \leq 0.01$

<sup>a</sup> Mean ± standard error

<sup>b</sup> n=9

**TABLE G2**  
**Hematology Data for Rats at the 15-Month Interim Evaluation in the 2-Year Inhalation Study of Acetonitrile<sup>a</sup>**

	0 ppm	100 ppm	200 ppm	400 ppm
<b>Male</b>				
n	8	8	8	8
Hematocrit (%)	43.8 ± 0.5	44.3 ± 0.3	44.2 ± 0.4	44.3 ± 0.4
Manual hematocrit (%)	46.1 ± 0.5	46.8 ± 0.3	46.9 ± 0.5	47.6 ± 0.6
Hemoglobin (g/dL)	15.1 ± 0.2	15.3 ± 0.1	15.3 ± 0.1	15.3 ± 0.1
Erythrocytes (10 <sup>6</sup> /μL)	8.94 ± 0.10	9.14 ± 0.06	9.08 ± 0.15	9.40 ± 0.10**
Mean cell volume (fL)	49.1 ± 0.4	48.5 ± 0.4	48.6 ± 0.6	47.0 ± 0.2**
Mean cell hemoglobin (pg)	16.9 ± 0.1	16.7 ± 0.1	16.9 ± 0.2	16.3 ± 0.1**
Mean cell hemoglobin concentration (g/dL)	34.5 ± 0.2	34.5 ± 0.1	34.6 ± 0.2	34.6 ± 0.2
Platelets (10 <sup>3</sup> /μL)	540.3 ± 30.6	519.9 ± 8.0	518.1 ± 19.3	504.4 ± 12.2
Reticulocytes (10 <sup>6</sup> /μL)	0.4 ± 0.0	0.4 ± 0.0	0.4 ± 0.0	0.3 ± 0.0
Leukocytes (10 <sup>3</sup> /μL)	5.54 ± 0.33 <sup>b</sup>	5.49 ± 0.25	5.60 ± 0.58	5.70 ± 0.27
Segmented neutrophils (10 <sup>3</sup> /μL)	1.84 ± 0.34 <sup>b</sup>	1.50 ± 0.15	1.73 ± 0.34	1.72 ± 0.19
Lymphocytes (10 <sup>3</sup> /μL)	3.58 ± 0.49 <sup>b</sup>	3.77 ± 0.19	3.75 ± 0.29	3.88 ± 0.23
Monocytes (10 <sup>3</sup> /μL)	0.06 ± 0.05 <sup>b</sup>	0.10 ± 0.03	0.06 ± 0.03	0.04 ± 0.02
Eosinophils (10 <sup>3</sup> /μL)	0.04 ± 0.02 <sup>b</sup>	0.09 ± 0.02	0.04 ± 0.02	0.06 ± 0.02
Nucleated erythrocytes (10 <sup>3</sup> /μL)	0.22 ± 0.06 <sup>b</sup>	0.12 ± 0.05	0.15 ± 0.05	0.16 ± 0.04
<b>Female</b>				
n	8	7	8	8
Hematocrit (%)	44.6 ± 0.4	43.2 ± 1.1	43.5 ± 0.5	42.2 ± 0.5**
Manual hematocrit (%)	46.6 ± 0.4	45.1 ± 1.0	45.6 ± 0.4	44.4 ± 0.5**
Hemoglobin (g/dL)	15.5 ± 0.1	15.0 ± 0.4	15.2 ± 0.1	14.7 ± 0.2**
Erythrocytes (10 <sup>6</sup> /μL)	8.40 ± 0.06	8.27 ± 0.12	8.26 ± 0.08	8.15 ± 0.08
Mean cell volume (fL)	53.1 ± 0.2	52.1 ± 0.7	52.6 ± 0.3	51.5 ± 0.3**
Mean cell hemoglobin (pg)	18.5 ± 0.1	18.1 ± 0.2	18.3 ± 0.1	18.0 ± 0.1**
Mean cell hemoglobin concentration (g/dL)	34.8 ± 0.1	34.7 ± 0.1	34.9 ± 0.2	34.8 ± 0.1
Platelets (10 <sup>3</sup> /μL)	483.9 ± 18.5	431.6 ± 20.7	464.5 ± 22.0	445.4 ± 14.6
Reticulocytes (10 <sup>6</sup> /μL)	0.2 ± 0.0	0.2 ± 0.0	0.2 ± 0.0	0.2 ± 0.0
Leukocytes (10 <sup>3</sup> /μL)	2.99 ± 0.16	3.60 ± 0.28	3.54 ± 0.31	3.99 ± 0.29*
Segmented neutrophils (10 <sup>3</sup> /μL)	0.70 ± 0.09	0.80 ± 0.14	0.91 ± 0.14	1.05 ± 0.18
Lymphocytes (10 <sup>3</sup> /μL)	2.15 ± 0.15	2.61 ± 0.19	2.38 ± 0.17	2.81 ± 0.25
Monocytes (10 <sup>3</sup> /μL)	0.10 ± 0.02	0.14 ± 0.06	0.18 ± 0.06	0.08 ± 0.02
Eosinophils (10 <sup>3</sup> /μL)	0.03 ± 0.01	0.05 ± 0.02	0.05 ± 0.01	0.05 ± 0.02
Nucleated erythrocytes (10 <sup>3</sup> /μL)	0.07 ± 0.02	0.12 ± 0.03	0.13 ± 0.03	0.13 ± 0.04

\* Significantly different (P≤0.05) from the control group by Dunn's or Shirley's test

\*\* P≤0.01

<sup>a</sup> Mean ± standard error

<sup>b</sup> n=7

## APPENDIX H

# CHEMICAL CHARACTERIZATION AND GENERATION OF CHAMBER CONCENTRATIONS

<b>PROCUREMENT AND CHARACTERIZATION OF ACETONITRILE</b> .....	<b>242</b>
<b>GENERATION AND MONITORING OF CHAMBER CONCENTRATIONS</b> .....	<b>243</b>
<b>FIGURE H1 Infrared Absorption Spectrum of Acetonitrile</b> .....	<b>245</b>
<b>FIGURE H2 Nuclear Magnetic Resonance Spectrum of Acetonitrile</b> .....	<b>246</b>
<b>FIGURE H3a Acetonitrile Liquid Vapor Generator</b> .....	<b>247</b>
<b>FIGURE H3b Acetonitrile Vapor Generation and Delivery System for the 2-Year Studies</b> .....	<b>248</b>
<b>FIGURE H4a Acetonitrile Inhalation Exposure Chamber for the 13-Week Studies</b> .....	<b>249</b>
<b>FIGURE H4b Acetonitrile Inhalation Exposure Chamber for the 2-Year Studies</b> .....	<b>250</b>
<b>FIGURE H5 Acetonitrile Exposure Suite</b> .....	<b>251</b>
<b>TABLE H1 Summary of Chamber Concentrations in the 13-Week Inhalation Studies of Acetonitrile</b> .....	<b>252</b>
<b>TABLE H2 Summary of Chamber Concentrations in the 2-Year Inhalation Studies of Acetonitrile</b> .....	<b>252</b>
<b>FIGURE H6 Monthly Mean Concentration and Standard Deviation in the 100 ppm Acetonitrile Rat Exposure Chamber for the 2-Year Study</b> .....	<b>253</b>
<b>FIGURE H7 Monthly Mean Concentration and Standard Deviation in the 200 ppm Acetonitrile Rat Exposure Chamber for the 2-Year Study</b> .....	<b>254</b>
<b>FIGURE H8 Monthly Mean Concentration and Standard Deviation in the 400 ppm Acetonitrile Rat Exposure Chamber for the 2-Year Study</b> .....	<b>255</b>
<b>FIGURE H9 Monthly Mean Concentration and Standard Deviation in the 50 ppm Acetonitrile Mouse Exposure Chamber for the 2-Year Study</b> .....	<b>256</b>
<b>FIGURE H10 Monthly Mean Concentration and Standard Deviation in the 100 ppm Acetonitrile Mouse Exposure Chamber for the 2-Year Study</b> .....	<b>257</b>
<b>FIGURE H11 Monthly Mean Concentration and Standard Deviation in the 200 ppm Acetonitrile Mouse Exposure Chamber for the 2-Year Study</b> .....	<b>258</b>

# CHEMICAL CHARACTERIZATION AND GENERATION OF CHAMBER CONCENTRATIONS

## PROCUREMENT AND CHARACTERIZATION OF ACETONITRILE

Acetonitrile was obtained in three lots (2485, B082889, and V041381). Lot 2485 was obtained from E.I. Dupont deNemours and Company, Inc. (Wilmington, DE), and was used throughout the 13-week studies and for the majority of the 2-year studies. Lots B082889, obtained from J.T. Baker (Phillipsburg, NJ), and V041381, obtained from Vistron Corporation (Cleveland, OH), and were used for a portion of the 2-year studies. Identity, purity, and stability analyses were conducted by the analytical chemistry laboratory, Midwest Research Institute (Kansas City, MO). Reports on analyses performed in support of the acetonitrile studies are on file at the National Institute of Environmental Health Sciences (NIEHS).

The chemical, a clear, colorless liquid, was identified as acetonitrile by infrared, ultraviolet/visible, and nuclear magnetic resonance spectroscopy. All spectra were consistent with the literature spectra (*Sadtler Standard Spectra*) of acetonitrile. The infrared and nuclear magnetic resonance spectra are presented in Figures H1 and H2.

The purity of each lot was determined by elemental analyses, Karl Fischer water analysis, free acid titration, and gas chromatography. For free acid titration, the samples were dissolved in water, titrated with 0.01 N sodium hydroxide, and monitored potentiometrically with an electrode filled with 3 M potassium chloride. Gas chromatography was performed using a flame ionization detector and a nitrogen carrier gas at a flow rate of 70 mL/minute. Two systems were used:

- A) Porapak QS on 100/120 mesh, with an oven temperature program of 50° C for 5 minutes, then 50° to 230° C at 10° C per minute,
- B) 10% Carbowax 20M-TPA on 80/100 Chromosorb W (AW), with an oven temperature program of 60° C for 6 minutes, then 60° to 200° C at 10° C per minute.

Concomitant analyses of each lot with an analytical chemistry laboratory sample were also performed. Samples of 0.5% acetonitrile in methanol containing 0.7% isopropanol as the internal standard were analyzed using system A, except with an isothermal oven temperature of 145° C.

Elemental analyses for carbon, hydrogen, and nitrogen were in agreement with the theoretical values for acetonitrile. Karl Fischer water analysis indicated 0.114%  $\pm$  0.003% (lot 2485), 0.11%  $\pm$  0.07% (lot B082889), and 0.19%  $\pm$  0.04% (lot V041381) water. Free acid titration indicated 33  $\pm$  1 ppm (lot 2485), 29  $\pm$  5 ppm (lot B082889), and 35  $\pm$  4 ppm (lot V041381). Gas chromatography by each system indicated one major peak and no impurities with areas greater than 0.1% relative to the major peak for lots 2485 and B082889. For lot V041381, gas chromatography using system A indicated one major peak and one impurity peak with an area of 0.14% relative to the major peak. System B indicated one major peak and no impurities with areas greater than 0.1% relative to the major peak. The concomitant analyses indicated purities of 99.4%  $\pm$  0.2% (lot 2485), 100.4%  $\pm$  0.3% (lot B082889), and 100.0%  $\pm$  0.3% (lot V041381). The overall purity for all lots was determined to be at least 99%.

Stability studies were performed by the analytical chemistry laboratory. Gas chromatography was performed using system A, except with an isothermal oven temperature of 145° C. These studies indicated that acetonitrile was stable as a bulk chemical for at least 2 weeks when stored protected from light, at temperatures up to 60° C. To ensure stability, the bulk chemical was stored at approximately 22° C in the original containers. The stability of the bulk chemical was monitored periodically by the study laboratory using gas chromatography and free acid titration methods similar to those previously described. No degradation of the bulk chemical was observed.

## GENERATION AND MONITORING OF CHAMBER CONCENTRATIONS

*Vapor Generation System.* Liquid acetonitrile was transferred from the original shipping container to a 5.6 L stainless steel reservoir. A nitrogen cover was maintained at all times while transferring the acetonitrile and in the reservoir. The reservoir was refilled approximately once (2-year studies) or twice (13-week studies) each week. Liquid was pumped from the reservoir to a vaporizer that consisted of a stainless steel cylinder heated to approximately  $177^{\circ}\text{F} \pm 8^{\circ}\text{F}$  (13-week studies) or  $200^{\circ}\text{F} \pm 5^{\circ}\text{F}$  (2-year studies) with a glass fiber wick (Figure H3a). Acetonitrile vapor was mixed with charcoal-filtered and HEPA-filtered air. The mixture was drawn into a stainless steel distribution manifold, diluted to the desired concentrations by adjusting the compressed air pressure to the vacuum pumps, and delivered to the exposure chambers once the concentrations in the distribution system had stabilized (Figure H3b). A Gardener Type CN Small Particle Detector (Gardner Associates, Schenectady, NY) was used prior to study start and again during the study with animals in chambers to check all chambers for any aerosol inadvertently produced during generation of the atmosphere. The study laboratory designed the inhalation exposure chamber, which was manufactured by Hartford System Division of Lab Products, Inc. (Aberdeen, MD) (Figures H4a and H4b), so that uniform vapor concentrations can be maintained throughout the chamber when the catchpans are in place. Total active mixing volume of each chamber is  $1.7\text{ m}^3$ . A diagram of the exposure suite is shown in Figure H5.

*Vapor Concentration Monitoring.* Chamber concentrations were monitored with a single on-line HP-5840 gas chromatograph equipped with a flame ionization detector and an OD nickel column packed with 80/100 Porapak Q. The nitrogen carrier gas flow rate was 30 mL/minute and the column temperature was  $130^{\circ}\text{C}$ . The monitor was coupled with the inhalation chambers using an automated, multiplexed, 8-port (13-week studies) or 12-port (2-year studies) sampling valve. Each chamber was sampled approximately twice hourly during the 13-week and 2-year studies. Calibration was accomplished by acquiring grab samples from each exposure chamber using dimethylformamide-filled, fritted-glass bubblers and a calibrated critical-orifice sampling system. These samples were analyzed against gravimetrically prepared standards using an off-line gas chromatograph. Samples were constantly drawn by vacuum through Teflon-lined stainless steel lines and the exhaust port of the 8-port or 12-port stream select valve. This constant flow assured the delivery of fresh sample to the stream select valve. Drift of the on-line gas chromatograph was monitored throughout exposure days using an on-line standard of acetonitrile in nitrogen.

*Chamber Concentration Monitoring.* Buildup and decay rates for chamber concentrations were determined with and without animals present in the chambers. The time to achieve 90% of target concentration after the start of vapor generation ( $T_{90}$ ) without animals was 9 to 12 minutes for the 13-week studies and 9 to 10 minutes for the 2-year studies. The  $T_{90}$  in chambers with animals was determined to be 15 to 17 minutes in the 13-week studies and 10 to 15 minutes in the 2-year studies. At a chamber airflow rate of 15 air changes per hour, the theoretical value for  $T_{90}$  is approximately 12.5 minutes. A  $T_{90}$  of 12 minutes was adopted for all studies. When longer buildup times were noted in the 2-year studies, the  $T_{90}$  times were reduced to the initial values by increasing air pressure to the delivery pumps during the initial 10 to 12 minutes of concentration buildup. This change in the operating procedure was followed throughout the remainder of the study. The time for chamber concentration to decay to 10% of the target concentration after vapor generation was terminated ( $T_{10}$ ) ranged from 12 to 14 minutes with or without animals in the 13-week studies and 7 to 12 minutes without animals or 14 to 17 minutes with animals in the 2-year studies.

Uniformity of vapor concentration in the inhalation exposure chambers was evaluated prior to the start of the 13-week studies, once during the 13-week studies, prior to the start of the 2-year studies, and approximately every 90 days during the 2-year studies. Vapor concentration was determined using the on-line gas chromatograph with the multipoint sample valve disabled to allow continuous monitoring from a single line. Chamber atmosphere uniformity (5% relative standard deviation) was maintained throughout the 13-week and 2-year studies.

Prior to the start of the 2-year studies, before animals were placed in the chambers and again during the study with animals in the chambers, a Gardner Type CN Small Particle Detector (Gardner Associates, Schenectady, NY) was used to check all chambers for any aerosol inadvertently produced during generation. The minimum resolution of the Gardner counter is approximately 200 particles/cm<sup>3</sup>. No counts above the minimum resolvable level were measured in any chamber.

The means of concentrations in all chambers for the 15-month interim evaluation ranged between 99% and 100% of the target, with relative standard deviations of 3%. At least 98% of all individual concentration measurements were within 10% of the target concentrations. The means of concentration in all chambers for the entire 2-year studies were 100% of the target with relative standard deviations of 3%. At least 99% of all individual concentration measurements were within 10% of the target concentrations.

Summaries of the chamber concentrations for the 13-week and 2-year studies are in Tables H1 and H2. The monthly mean exposure concentrations in the chambers for the 2-year studies are presented in Figures H6-H11.

*Acetonitrile Degradation.* Studies of acetonitrile degradation were conducted during the 13-week studies in the 100 and 1,600 ppm chambers, and during the 2-year studies in the 50 and 400 ppm chambers and in the vapor distribution line. Samples were obtained from occupied and unoccupied exposure chambers and the vapor distribution line using charcoal-filled adsorbent tubes. The tubes were desorbed with methanol and dimethylformamide and the desorbed samples were analyzed for acetonitrile, propionitrile, allyl alcohol, and acrylonitrile using gas chromatography. The results of these analyses indicated that no test chemical degradation occurred in the chambers or in the vapor distribution line as a result of test chemical generation.

Sample analysis indicated that propionitrile, acrylonitrile, and allyl alcohol were present as impurities in the test material, although the concentrations were very low. Of these impurities, only propionitrile was observed in generated atmospheres of acetonitrile. However, the measured concentration of propionitrile in generated test atmospheres ranged from <0.1% to 0.2% by weight relative to acetonitrile. Analyses indicated that allyl alcohol and acrylonitrile were below the detection limit in the chambers and vapor distribution line, and their relative amounts were substantially less than 1% by weight at all sampling locations.

Samples of acetonitrile were obtained from the generator reservoir when the reservoir was filled, after days 7, 14, and 21 during the 13-week studies, and after day 6 of the 2-year studies. Analysis of acetonitrile samples from the generator reservoir indicated that the purity of the test chemical was maintained.



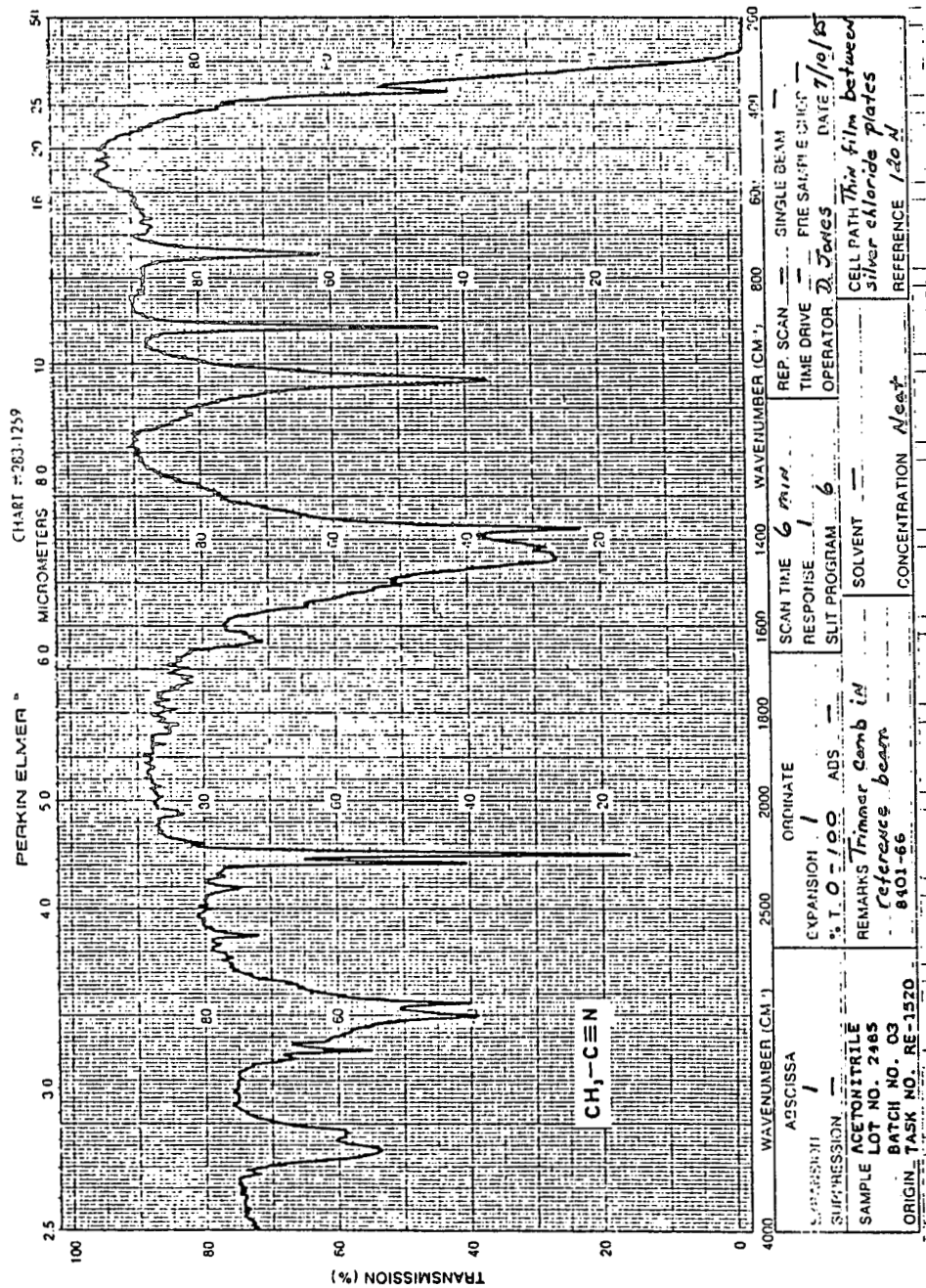
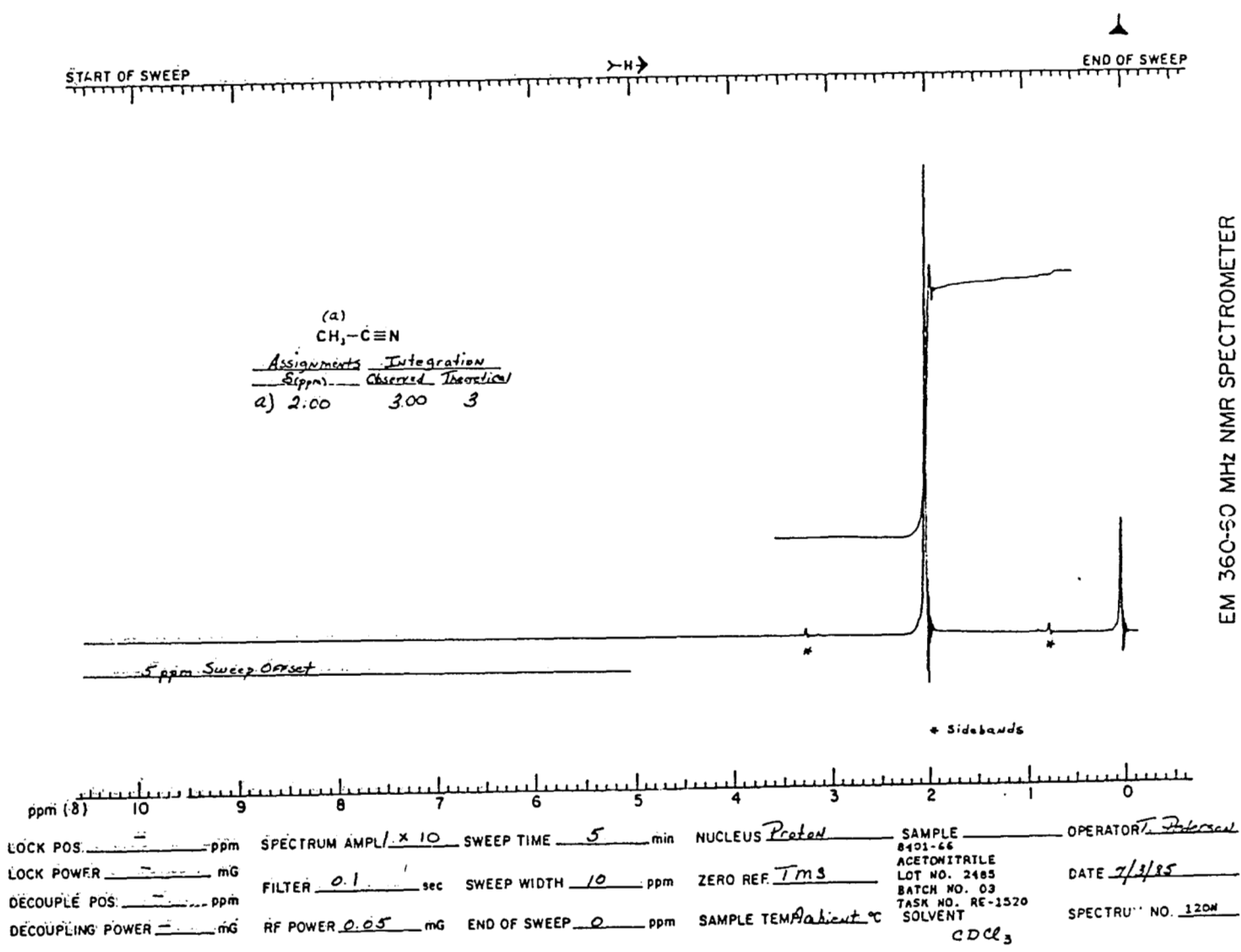

FIGURE H1  
Infrared Absorption Spectrum of Acetonitrile

FIGURE H2  
Nuclear Magnetic Resonance Spectrum of Acetonitrile



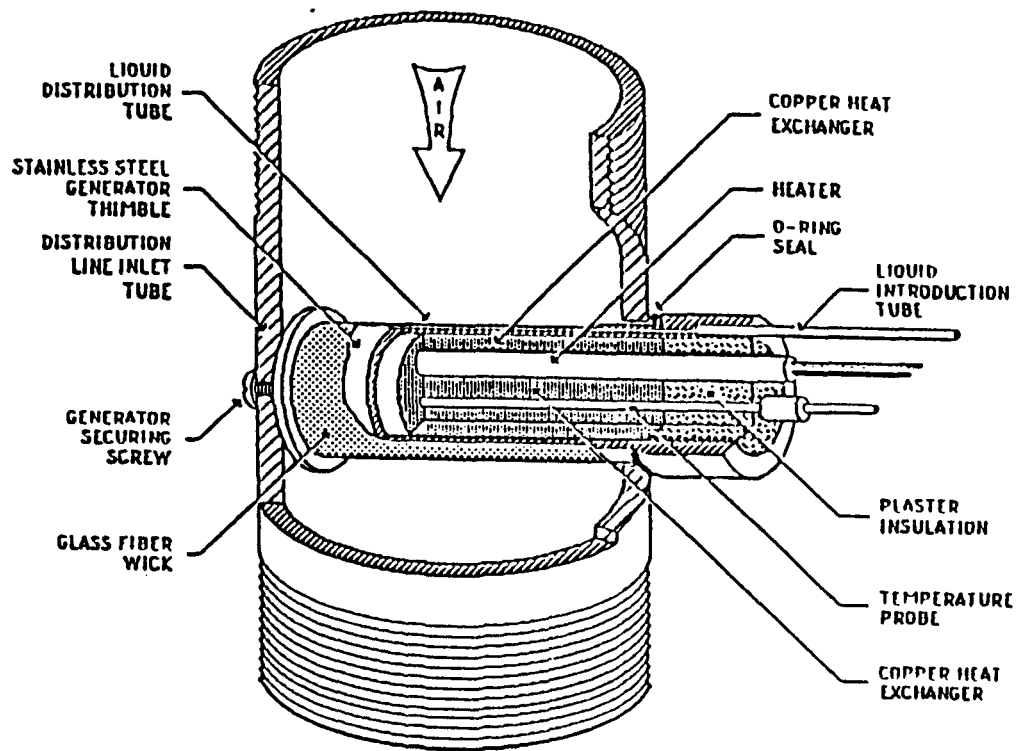
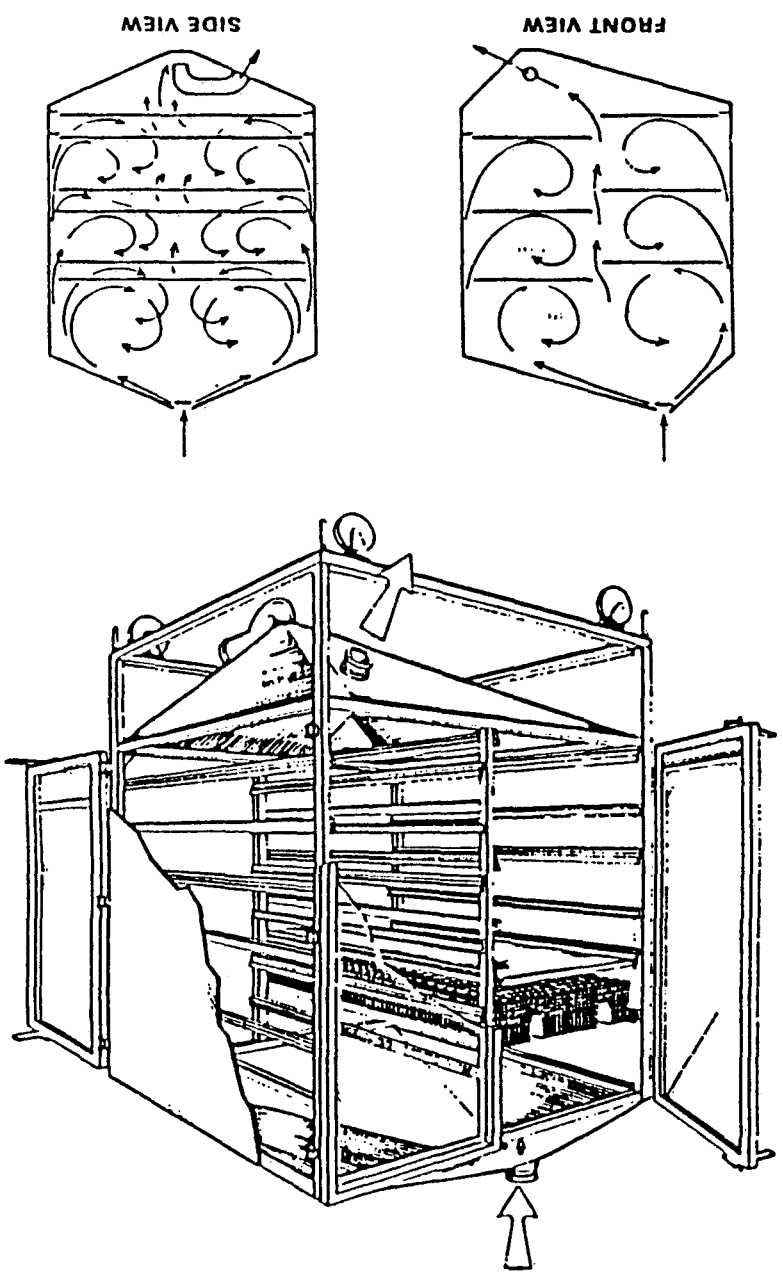

FIGURE H3a  
Acetonitrile Liquid Vapor Generator

FIGURE H3b  
Acetonitrile Vapor Generation and Delivery System for the 2-Year Studies



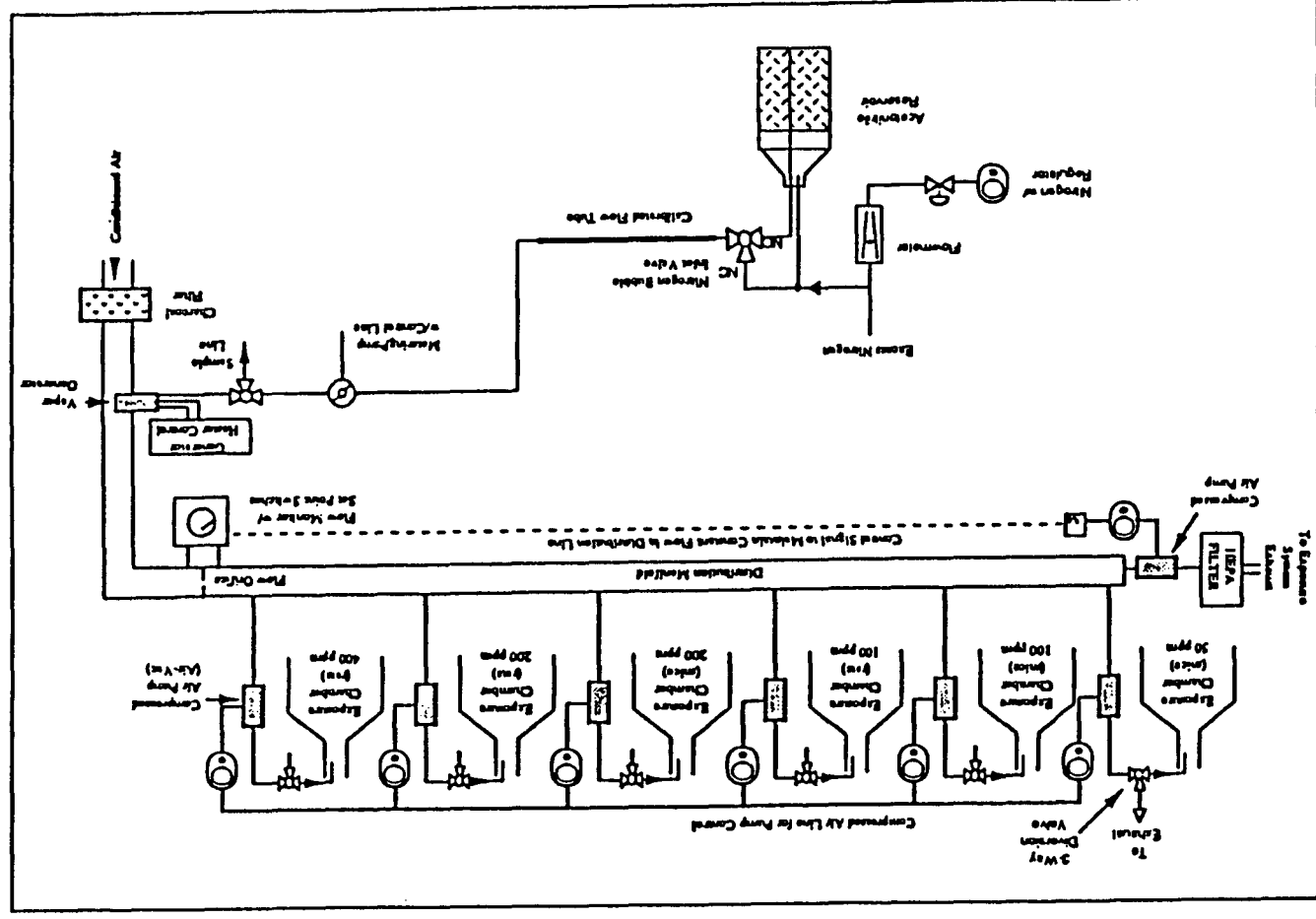
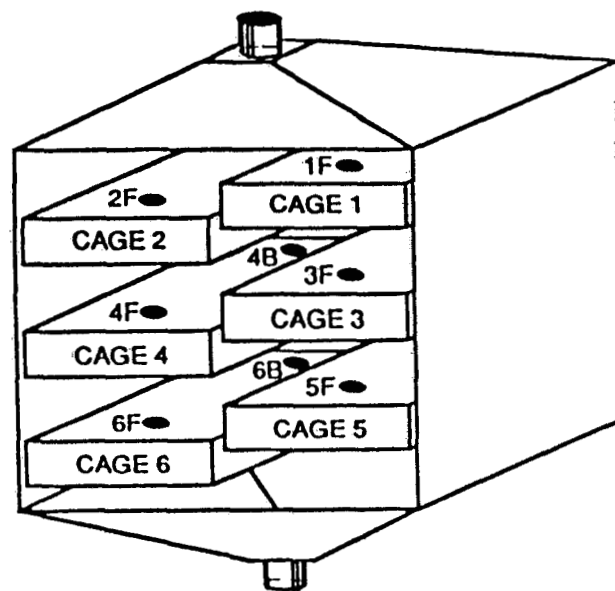

FIGURE H4a  
Acetonitrile Inhalation Exposure Chamber for the 13-Week Studies



**FIGURE H4b**  
**Acetonitrile Inhalation Exposure Chamber for the 2-Year Studies**

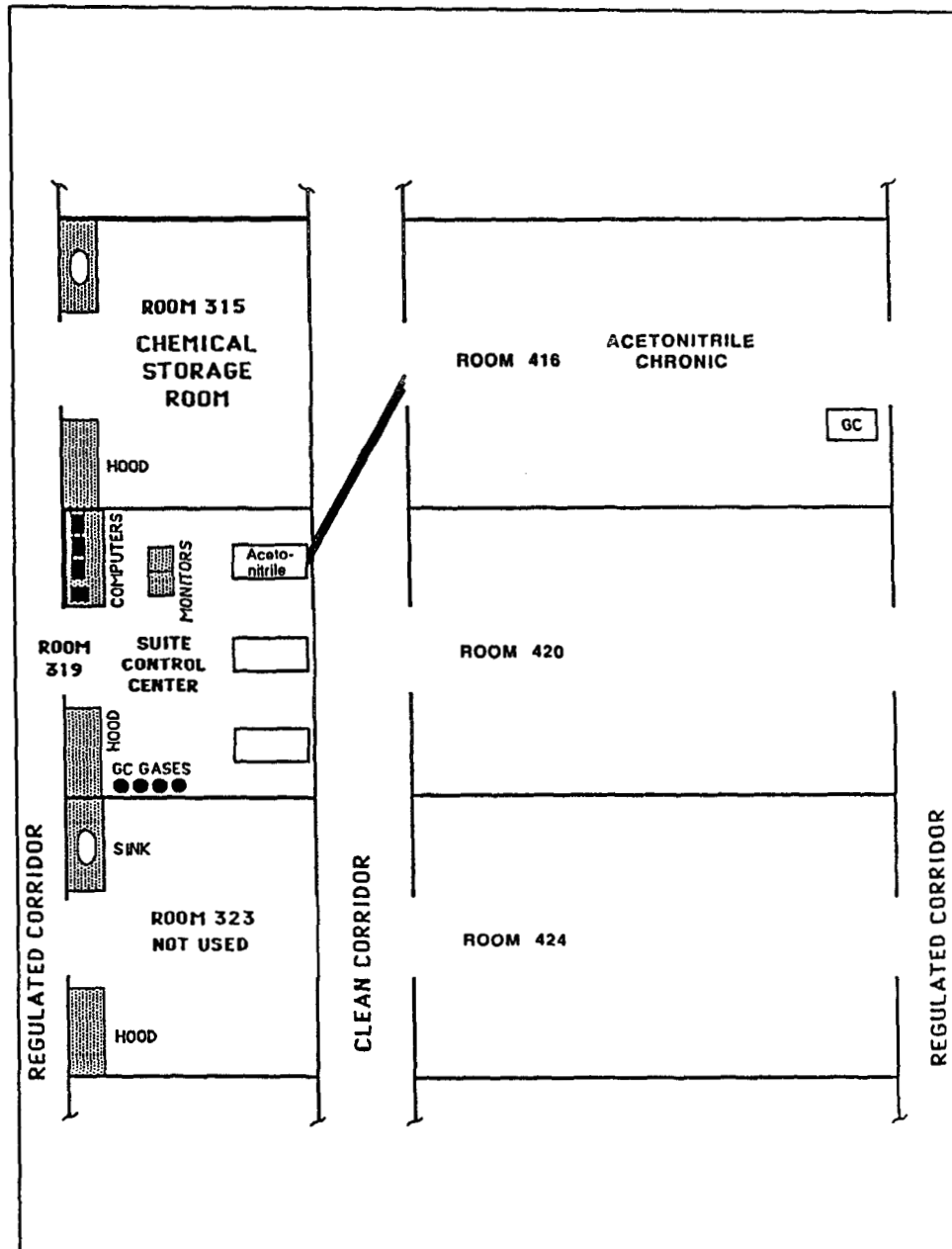

FIGURE H5  
Acetonitrile Exposure Suite

**TABLE H1**  
**Summary of Chamber Concentrations in the 13-Week Inhalation Studies of Acetonitrile**

Target Concentration (ppm)	Total Number of Readings	Average Concentration <sup>a</sup> (ppm)
<b>Rat Chambers</b>		
100	778	101 ± 5.5
200	823	199 ± 14
400	823	397 ± 25
800	818	799 ± 42
1,600	819	1,590 ± 76
<b>Mouse Chambers</b>		
100	793	101 ± 6.1
200	840	199 ± 14
400	840	397 ± 27
800	835	798 ± 49
1,600	836	1,590 ± 88

<sup>a</sup> Mean ± standard deviation

**TABLE H2**  
**Summary of Chamber Concentrations in the 2-Year Inhalation Studies of Acetonitrile**

Target Concentration (ppm)	Total Number of Readings	Average Concentration <sup>a</sup> (ppm)
<b>Rat Chambers</b>		
100	6,242	100 ± 2.9
200	6,262	199 ± 6.0
400	6,020	400 ± 11.4
<b>Mouse Chambers</b>		
50	6,244	49.8 ± 1.6
100	6,262	100 ± 3.4
200	6,371	200 ± 6.0

<sup>a</sup> Mean ± standard deviation



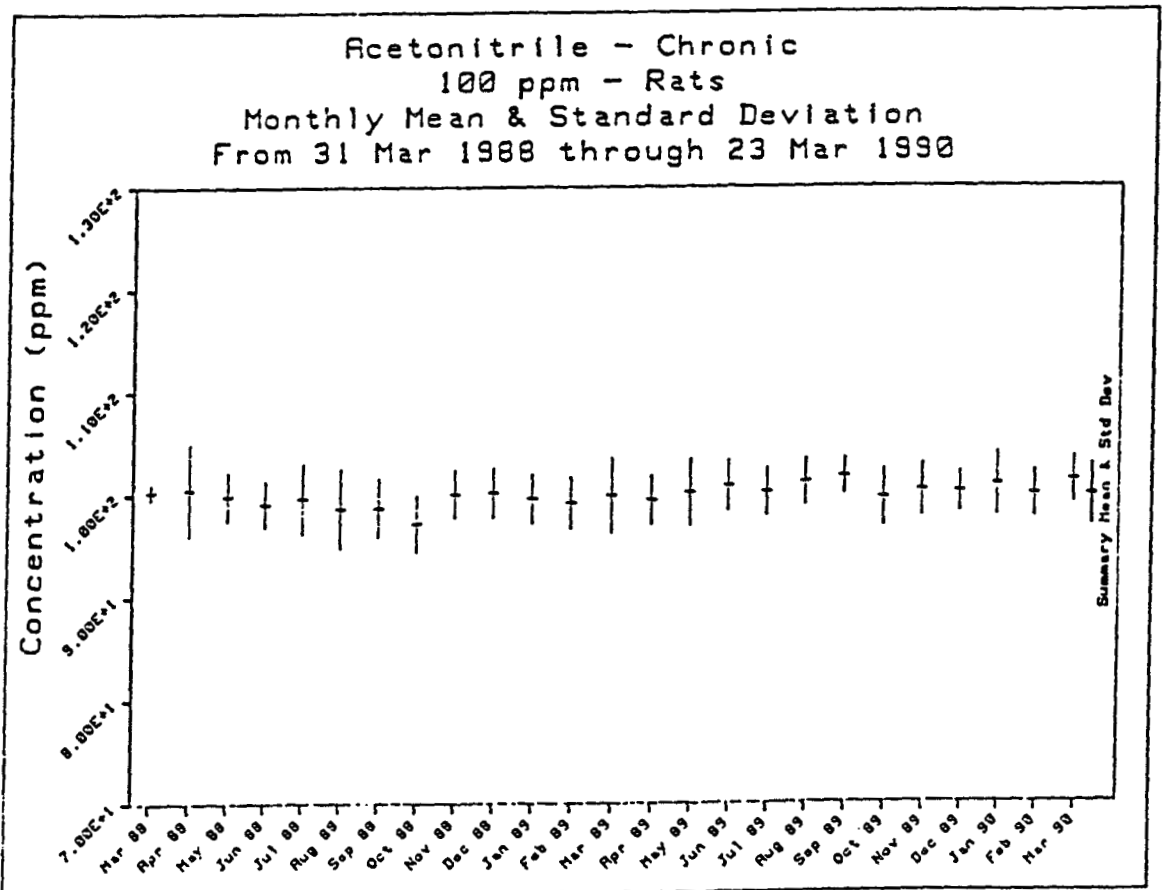
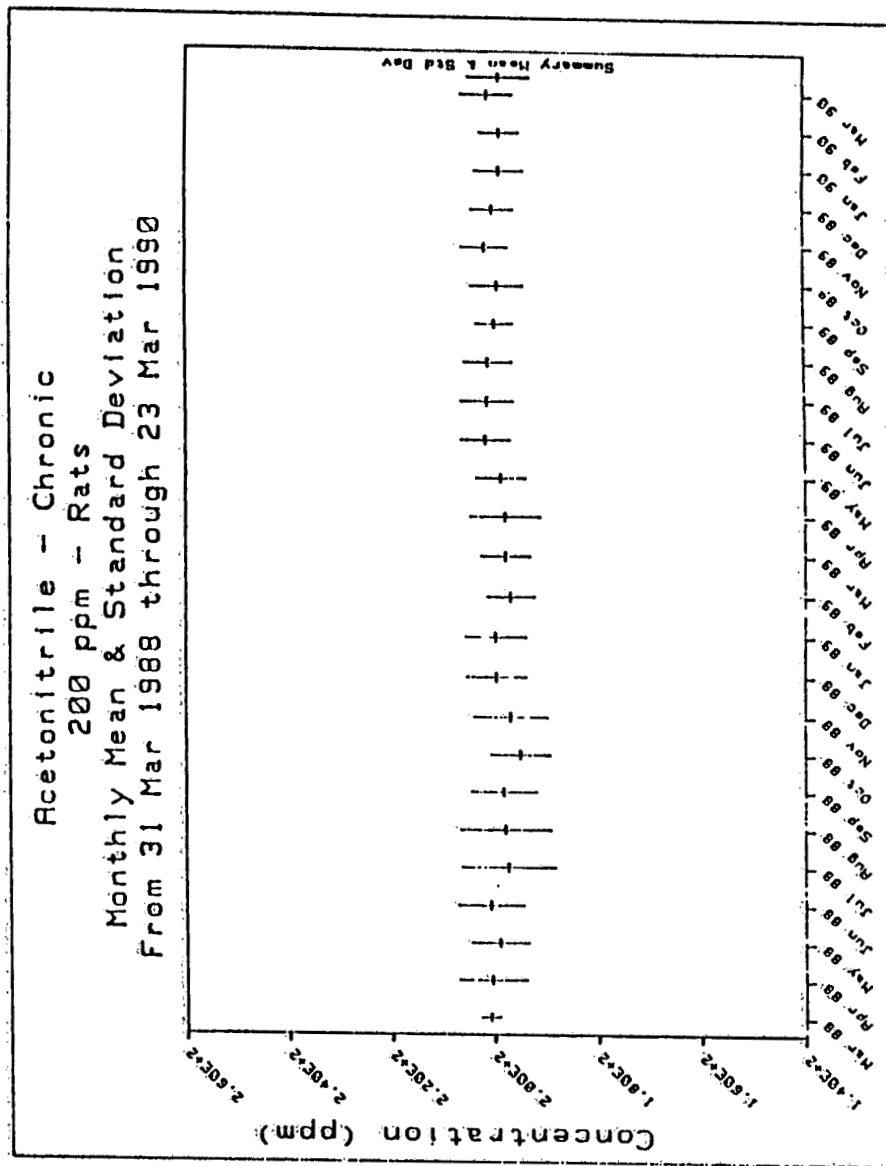
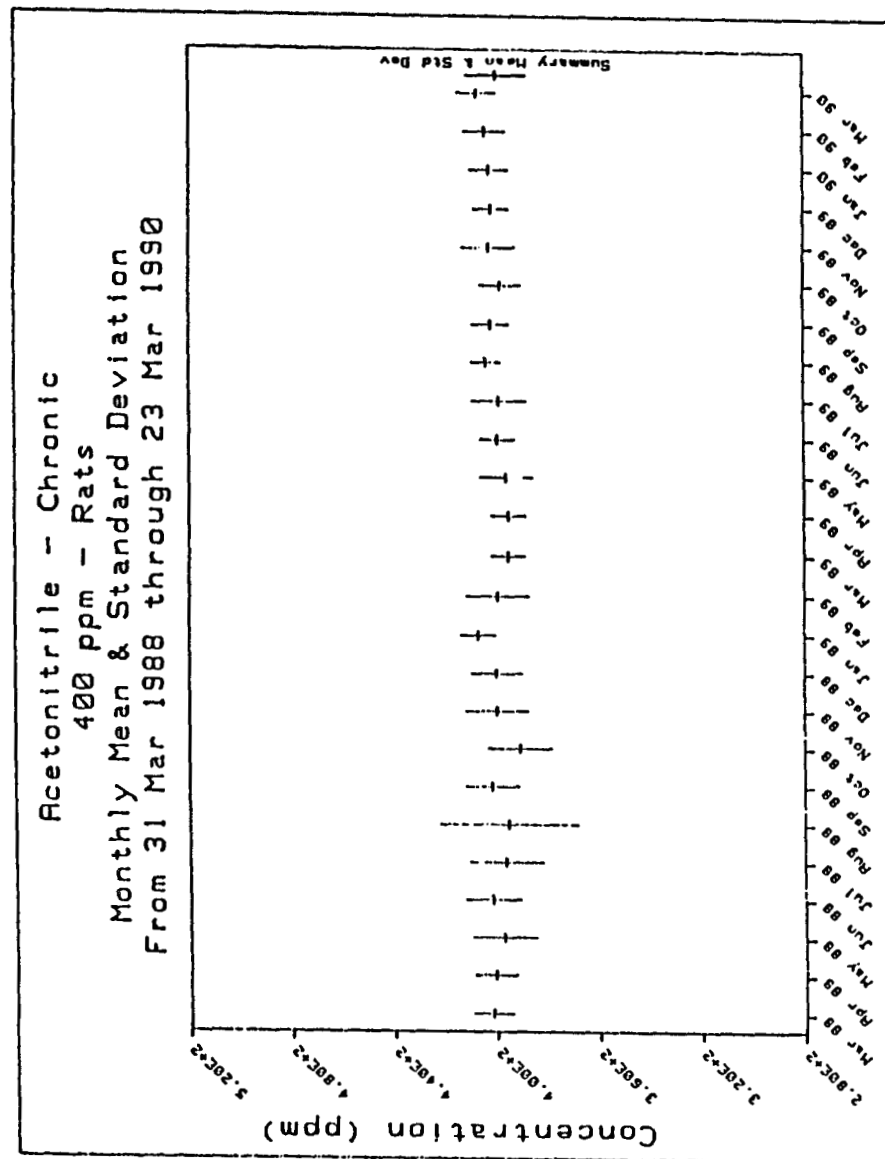

FIGURE H6  
Monthly Mean Concentration and Standard Deviation  
in the 100 ppm Acetonitrile Rat Exposure Chamber for the 2-Year Study



**FIGURE H7**  
**Monthly Mean Concentration and Standard Deviation**  
**in the 200 ppm Acetonitrile Rat Exposure Chamber for the 2-Year Study**



**FIGURE H8**  
**Monthly Mean Concentration and Standard Deviation**  
**in the 400 ppm Acetonitrile Rat Exposure Chamber for the 2-Year Study**

FIGURE H9  
 Monthly Mean Concentration and Standard Deviation  
 in the 50 ppm Acetonitrile Mouse Exposure Chamber for the 2-Year Study

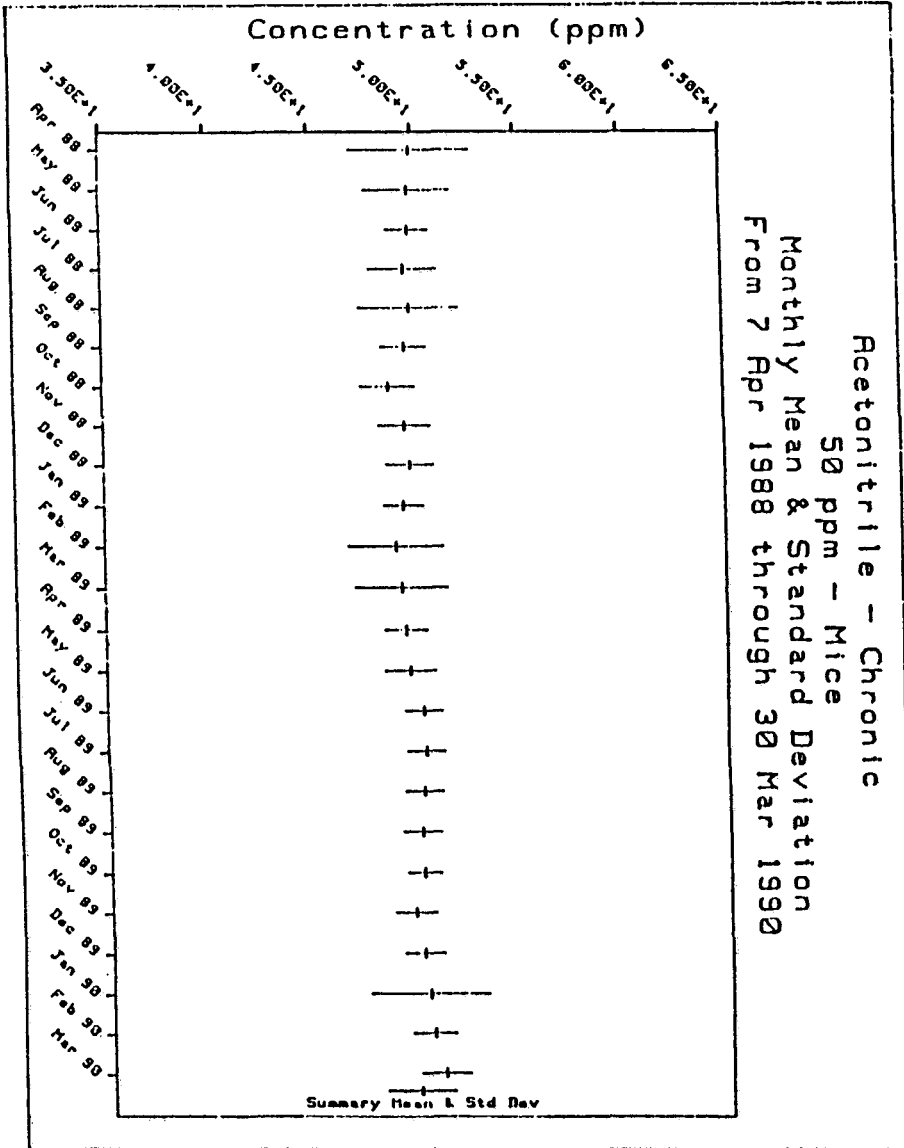
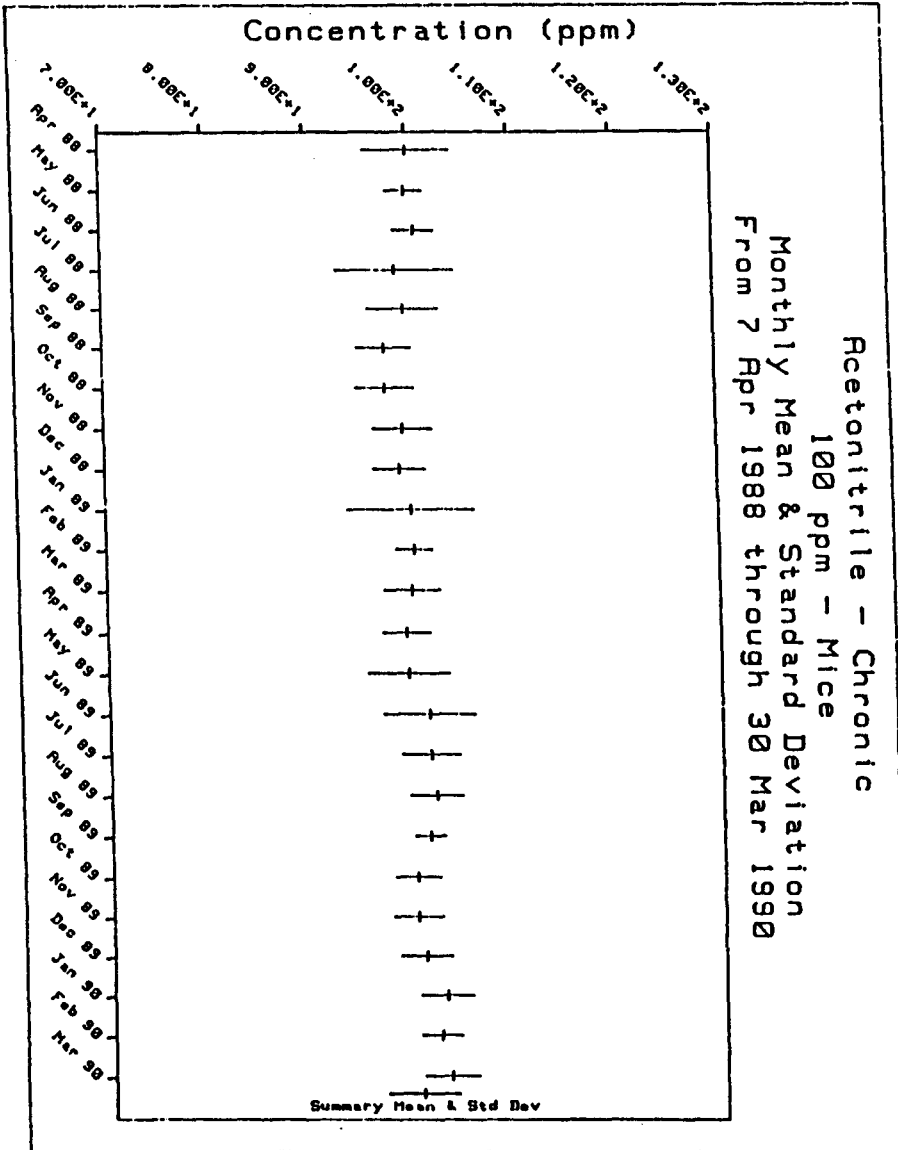

FIGURE H10  
 Monthly Mean Concentration and Standard Deviation  
 in the 100 ppm Acetonitrile Mouse Exposure Chamber for the 2-Year Study



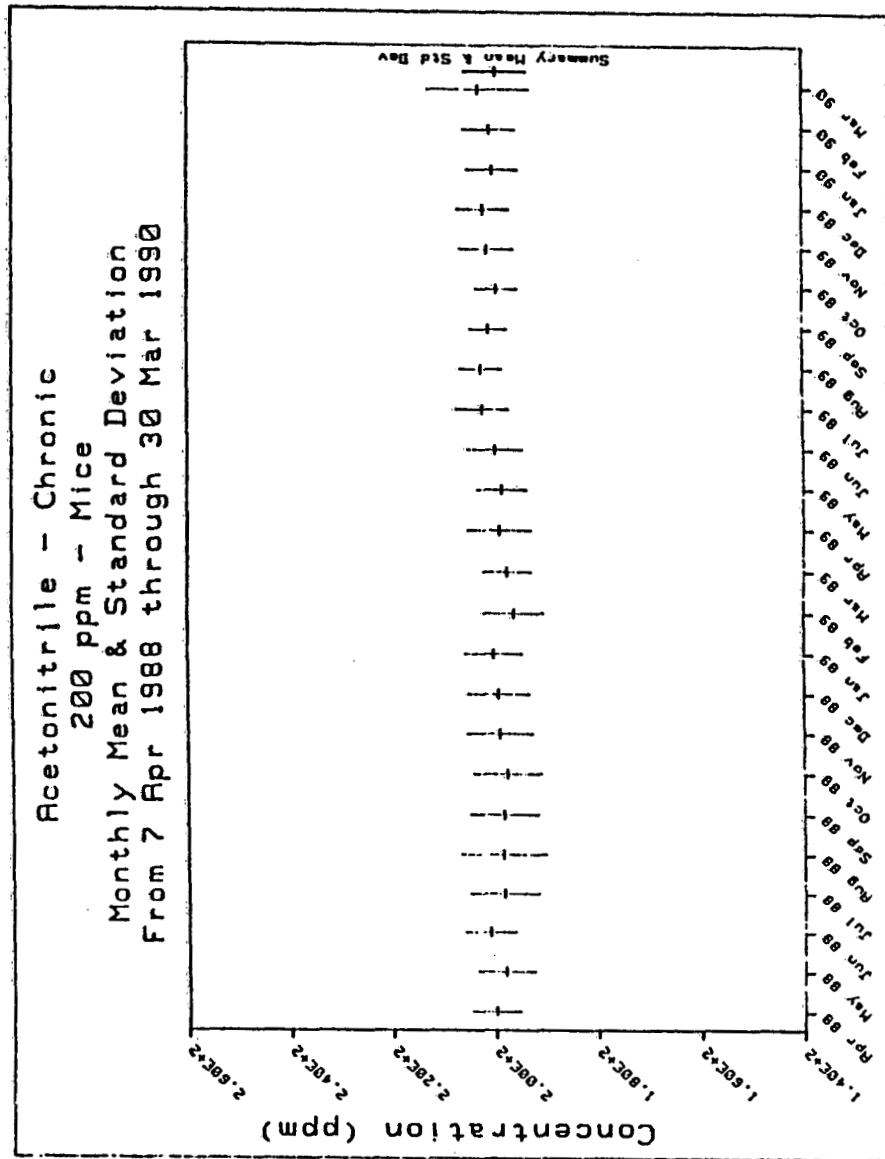

FIGURE H11  
Monthly Mean Concentration and Standard Deviation  
in the 200 ppm Acetonitrile Mouse Exposure Chamber for the 2-Year Study

**APPENDIX I**  
**INGREDIENTS, NUTRIENT COMPOSITION,**  
**AND CONTAMINANT LEVELS**  
**IN NIH-07 RAT AND MOUSE RATION**

<b>TABLE I1</b>	<b>Ingredients of NIH-07 Rat and Mouse Ration .....</b>	<b>260</b>
<b>TABLE I2</b>	<b>Vitamins and Minerals in NIH-07 Rat and Mouse Ration .....</b>	<b>260</b>
<b>TABLE I3</b>	<b>Nutrient Composition of NIH-07 Rat and Mouse Ration .....</b>	<b>261</b>
<b>TABLE I4</b>	<b>Contaminant Levels in NIH-07 Rat and Mouse Ration .....</b>	<b>262</b>

**TABLE I1**  
**Ingredients of NIH-07 Rat and Mouse Ration<sup>a</sup>**

Ingredients <sup>b</sup>	Percent by Weight
Ground #2 yellow shelled corn	24.50
Ground hard winter wheat	23.00
Soybean meal (49% protein)	12.00
Fish meal (60% protein)	10.00
Wheat middlings	10.00
Dried skim milk	5.00
Alfalfa meal (dehydrated, 17% protein)	4.00
Corn gluten meal (60% protein)	3.00
Soy oil	2.50
Dried brewer's yeast	2.00
Dry molasses	1.50
Dicalcium phosphate	1.25
Ground limestone	0.50
Salt	0.50
Premixes (vitamin and mineral)	0.25

<sup>a</sup> NCI, 1976; NIH, 1978

<sup>b</sup> Ingredients were ground to pass through a U.S. Standard Screen No. 16 before being mixed.

**TABLE I2**  
**Vitamins and Minerals in NIH-07 Rat and Mouse Ration<sup>a</sup>**

	Amount	Source
<b>Vitamins</b>		
A	5,500,000 IU	Stabilized vitamin A palmitate or acetate
D <sub>3</sub>	4,600,000 IU	D-activated animal sterol
K <sub>3</sub>	2.8 g	Menadione
<i>d</i> - $\alpha$ -Tocopheryl acetate	20,000 IU	
Choline	560.0 g	Choline chloride
Folic acid	2.2 g	
Niacin	30.0 g	
<i>d</i> -Pantothenic acid	18.0 g	<i>d</i> -Calcium pantothenate
Riboflavin	3.4 g	
Thiamine	10.0 g	Thiamine mononitrate
B <sub>12</sub>	4,000 $\mu$ g	
Pyridoxine	1.7 g	Pyridoxine hydrochloride
Biotin	140.0 mg	<i>d</i> -Biotin
<b>Minerals</b>		
Iron	120.0 g	Iron sulfate
Manganese	60.0 g	Manganous oxide
Zinc	16.0 g	Zinc oxide
Copper	4.0 g	Copper sulfate
Iodine	1.4 g	Calcium iodate
Cobalt	0.4 g	Cobalt carbonate

<sup>a</sup> Per ton (2,000 lb) of finished product.



**TABLE I3**  
**Nutrient Composition of NIH-07 Rat and Mouse Ration**

Nutrient	Mean $\pm$ Standard Deviation	Range	Number of Samples
Protein (% by weight)	22.93 $\pm$ 0.76	21.70 – 24.20	26
Crude fat (% by weight)	5.39 $\pm$ 0.34	4.60 – 5.90	26
Crude fiber (% by weight)	3.61 $\pm$ 0.39	2.80 – 4.30	26
Ash (% by weight)	6.63 $\pm$ 0.29	6.11 – 7.30	26
<b>Amino Acids (% of total diet)</b>			
Arginine	1.287 $\pm$ 0.084	1.100 – 1.390	10
Cystine	0.306 $\pm$ 0.075	0.181 – 0.400	10
Glycine	1.160 $\pm$ 0.050	1.060 – 1.220	10
Histidine	0.580 $\pm$ 0.024	0.531 – 0.608	10
Isoleucine	0.917 $\pm$ 0.034	0.867 – 0.965	10
Leucine	1.972 $\pm$ 0.052	1.850 – 2.040	10
Lysine	1.273 $\pm$ 0.051	1.200 – 1.370	10
Methionine	0.437 $\pm$ 0.115	0.306 – 0.699	10
Phenylalanine	0.994 $\pm$ 0.125	0.665 – 1.110	10
Threonine	0.896 $\pm$ 0.055	0.824 – 0.985	10
Tryptophan	0.223 $\pm$ 0.160	0.107 – 0.671	10
Tyrosine	0.677 $\pm$ 0.105	0.564 – 0.794	10
Valine	1.089 $\pm$ 0.057	0.962 – 1.170	10
<b>Essential Fatty Acids (% of total diet)</b>			
Linoleic	2.389 $\pm$ 0.233	1.830 – 2.570	9
Linolenic	0.277 $\pm$ 0.036	0.210 – 0.320	9
<b>Vitamins</b>			
Vitamin A (IU/kg)	6,532 $\pm$ 1,894	4,180 – 12,140	26
Vitamin D (IU/kg)	4,450 $\pm$ 1,382	3,000 – 6,300	4
$\alpha$ -Tocopherol (ppm)	36.92 $\pm$ 9.32	22.5 – 48.9	9
Thiamine (ppm)	18.69 $\pm$ 2.53	14.0 – 28.0	26
Riboflavin (ppm)	7.92 $\pm$ 0.93	6.10 – 9.00	10
Niacin (ppm)	100.95 $\pm$ 25.92	65.0 – 150.0	9
Pantothenic acid (ppm)	30.30 $\pm$ 3.60	23.0 – 34.6	10
Pyridoxine (ppm)	9.25 $\pm$ 2.62	5.60 – 14.0	10
Folic acid (ppm)	2.51 $\pm$ 0.64	1.80 – 3.70	10
Biotin (ppm)	0.267 $\pm$ 0.049	0.19 – 0.35	10
Vitamin B <sub>12</sub> (ppb)	40.14 $\pm$ 20.04	10.6 – 65.0	10
Choline (ppm)	3,068 $\pm$ 314	2,400 – 3,430	9
<b>Minerals</b>			
Calcium (%)	1.24 $\pm$ 0.11	1.00 – 1.54	26
Phosphorus (%)	0.95 $\pm$ 0.03	0.90 – 1.00	26
Potassium (%)	0.887 $\pm$ 0.067	0.772 – 0.971	8
Chloride (%)	0.526 $\pm$ 0.092	0.380 – 0.635	8
Sodium (%)	0.315 $\pm$ 0.344	0.258 – 0.370	10
Magnesium (%)	0.168 $\pm$ 0.008	0.151 – 0.180	10
Sulfur (%)	0.274 $\pm$ 0.063	0.208 – 0.420	10
Iron (ppm)	356.2 $\pm$ 90.0	255.0 – 523.0	10
Manganese (ppm)	92.24 $\pm$ 5.35	81.70 – 99.40	10
Zinc (ppm)	58.14 $\pm$ 9.91	46.10 – 81.60	10
Copper (ppm)	11.50 $\pm$ 2.40	8.090 – 15.39	10
Iodine (ppm)	3.70 $\pm$ 1.14	1.52 – 5.83	10
Chromium (ppm)	1.71 $\pm$ 0.45	0.85 – 2.09	9
Cobalt (ppm)	0.797 $\pm$ 0.23	0.490 – 1.150	6

**TABLE I4**  
**Contaminant Levels in NIH-07 Rat and Mouse Ration**

	Mean $\pm$ Standard Deviation <sup>a</sup>	Range	Number of Samples
<b>Contaminants</b>			
Arsenic (ppm)	0.22 $\pm$ 0.16	0.05 – 0.60	26
Cadmium (ppm)	<0.20		26
Lead (ppm)	0.25 $\pm$ 0.17	0.10 – 1.00	26
Mercury (ppm) <sup>b</sup>	0.05 $\pm$ 0.02	0.02 – 0.11	26
Selenium (ppm)	0.41 $\pm$ 0.24	0.16 – 1.21	26
Aflatoxins (ppb) <sup>c</sup>	<5.0		26
Nitrate nitrogen (ppm) <sup>d</sup>	15.86 $\pm$ 3.93	8.60 – 24.0	26
Nitrite nitrogen (ppm) <sup>d</sup>	0.19 $\pm$ 0.15	<0.10 – 0.60	26
BHA (ppm) <sup>e</sup>	1.58 $\pm$ 0.63	<0.10 – 3.00	26
BHT (ppm) <sup>e</sup>	1.27 $\pm$ 0.59	<0.10 – 3.00	26
Aerobic plate count (CFU/g) <sup>f</sup>	65,142 $\pm$ 70,838	6,700 – 320,000	26
Coliform (MPN/g) <sup>g,h</sup>	5.04 $\pm$ 5.37	3.00 – 23.0	25
Coliform (MPN/g) <sup>i</sup>	47.15 $\pm$ 215	3.00 – 1,100	26
<i>Escherichia coli</i> (MPN/g) <sup>j</sup>	3.00 $\pm$ 0.20	3.00 – 4.00	26
Total nitrosoamines (ppb) <sup>k</sup>	8.81 $\pm$ 3.93	3.60 – 19.40	26
<i>N</i> -Nitrosodimethylamine (ppb) <sup>k</sup>	6.53 $\pm$ 3.22	2.60 – 14.00	26
<i>N</i> -Nitrosopyrrolidine (ppb) <sup>k</sup>	2.28 $\pm$ 1.38	0.90 – 5.40	26
<b>Pesticides (ppm)</b>			
$\alpha$ -BHC <sup>l</sup>	<0.01		26
$\beta$ -BHC	<0.02		26
$\gamma$ -BHC	<0.01		26
$\delta$ -BHC	<0.01		26
Heptachlor	<0.01		26
Aldrin	<0.01		26
Heptachlor epoxide	<0.01		26
DDE	<0.01		26
DDD	<0.01		26
DDT	<0.01		26
HCB	<0.01		26
Mirex	<0.01		26
Methoxychlor	<0.05		26
Dieldrin	<0.01		26
Endrin	<0.01		26
Telodrin	<0.01		26
Chlordane	<0.05		26
Toxaphene	<0.1		26
Estimated PCBs	<0.2		26
Ronnel	<0.01		26
Ethion	<0.02		26
Trithion	<0.05		26
Diazinon	<0.1		26
Methyl parathion	<0.02		26
Ethyl parathion	<0.02		26
Malathion	0.23 $\pm$ 0.23	<0.05 – 1.00	26
Endosulfan I	<0.01		26
Endosulfan II	<0.01		26
Endosulfan sulfate	<0.03		26

**Table I4**  
**Contaminant Levels in NIH-07 Rat and Mouse Ration** (continued)

---

- <sup>a</sup> For values less than the limit of detection, the detection limit is given as the mean.
- <sup>b</sup> All values were less than the detection limit except the lot milled on 3 February 1989, which contained 0.11 ppm.
- <sup>c</sup> No aflatoxin measurement was recorded for the lot milled 2 October 1989.
- <sup>d</sup> Sources of contamination: alfalfa, grains, and fish meal
- <sup>e</sup> Sources of contamination: soy oil and fish meal
- <sup>f</sup> CFU = colony forming units
- <sup>g</sup> MPN = most probable number
- <sup>h</sup> Mean, standard deviation, and range exclude one large value of 1,100 MPN/g obtained in the lot milled 5 July 1988.
- <sup>i</sup> Mean, standard deviation, and range include one large value of 1,100 MPN/g obtained in the lot milled 5 July 1988.
- <sup>j</sup> All values were less than the detection limit except the lot milled on 4 April 1988, which contained 4.0 MPN/g.
- <sup>k</sup> All values were corrected for percent recovery.
- <sup>l</sup> BHC = hexachlorocyclohexane or benzene hexachloride

**APPENDIX J**  
**SENTINEL ANIMAL PROGRAM**

**METHODS** ..... **266**  
**RESULTS** ..... **268**

## SENTINEL ANIMAL PROGRAM

### METHODS

Rodents used in the Carcinogenesis Program of the National Toxicology Program are produced in optimally clean facilities to eliminate potential pathogens that may affect study results. The Sentinel Animal Program is part of the periodic monitoring of animal health that occurs during the toxicologic evaluation of chemical compounds. Under this program, the disease state of the rodents is monitored via serology on sera from extra (sentinel) animals in the study rooms. These animals and the study animals are all subject to identical environmental conditions. The sentinel animals come from the same production source and weanling groups as the animals used for the studies of chemical compounds.

### Rats

For the 13-week study, samples were obtained from five male and five female controls during week 4 and at terminal sacrifice. These samples were processed appropriately and were submitted to Microbiological Associates, Inc. (Bethesda, MD), for viral titer screening. The following tests were performed:

<u>Method of Analysis</u>	<u>Time of Analysis</u>
Complement Fixation	
LCM (lymphocytic choriomeningitis virus)	Study termination
ELISA	
<i>Mycoplasma arthritidis</i>	4 weeks and study termination
<i>Mycoplasma pulmonis</i>	4 weeks and study termination
PVM (pneumonia virus of mice)	4 weeks and study termination
RCV (rat coronavirus)	4 weeks
Sendai	4 weeks and study termination
Hemagglutination Inhibition	
H-1 (Toolan's H-1 virus)	4 weeks and study termination
K (papovavirus)	Study termination
KRV (Kilham rat virus)	4 weeks
MVM (minute virus of mice)	Study termination
Polyoma virus	Study termination
Immunofluorescence Assay	
EDIM (epizootic diarrhea of infant mice)	Study termination

For the 2-year study, eight male and eight female rats were selected at the time of randomization and allocation of the animals and were housed two per sex per exposure chamber. Sera were obtained from these animals at 6, 12, and 18 months. Following the 18-month bleeding, the animals were necropsied. Sera for the 24-month screening were obtained from five male and five female rats receiving 200 ppm. Blood from each collection was processed appropriately, shipped to Microbiological Associates, Inc., and screened for the following:

<u>Method of Analysis</u>	<u>Time of Analysis</u>
ELISA	
<i>M. arthritidis</i>	24 months
<i>M. pulmonis</i>	24 months
PVM	6, 12, 18, and 24 months
RCV/SDA (rat coronavirus/ sialodacryoadenitis virus)	6, 12, 18, and 24 months
Sendai	6, 12, 18, and 24 months
Hemagglutination Inhibition	
H-1	6, 12, 18, and 24 months
KRV	6, 12, 18, and 24 months

### Mice

For the 13-week study, samples were obtained from five male and five female controls at terminal sacrifice. These samples were processed appropriately and were submitted to Microbiological Associates, Inc., for viral titer screening. The following tests were performed:

<u>Method of Analysis</u>	<u>Time of Analysis</u>
Complement Fixation	
LCM	Study termination
ELISA	
Ectromelia virus	Study termination
GDVII (mouse encephalomyelitis virus)	Study termination
Mouse adenoma virus	Study termination
MHV (mouse hepatitis virus)	Study termination
<i>M. arthritidis</i>	Study termination
<i>M. pulmonis</i>	Study termination
PVM	Study termination
Reovirus 3	Study termination
Sendai	Study termination
Hemagglutination Inhibition	
K	Study termination
MVM	Study termination
Polyoma virus	Study termination
Immunofluorescence Assay	
EDIM	Study termination

For the 2-year study, 15 male and 15 female mice were selected at the time of randomization and allocation of the animals to the various study groups and were housed in the control chamber. Sera were obtained from five males and five females at 6, 12, and 18 months. Sera for the 24-month screening were obtained from five males and five females receiving 100 ppm. Blood from each collection was processed appropriately, shipped to Microbiological Associates, Inc., and screened for the following:

<u>Method of Analysis</u>	<u>Time of Analysis</u>
<b>ELISA</b>	
Ectromelia virus	6, 12, 18, and 24 months
EDIM	24 months
GDVII	6, 12, 18, and 24 months
LCM	18 and 24 months
MVM	6 and 12 months
Mouse adenoma virus	6, 12, and 18 months
MHV	6, 12, 18, and 24 months
<i>M. arthritidis</i>	24 months
<i>M. pulmonis</i>	24 months
PVM	6, 12, 18, and 24 months
Reovirus 3	6, 12, 18, and 24 months
Sendai	6, 12, 18, and 24 months
<b>Hemagglutination Inhibition</b>	
K	6, 12, 18, and 24 months
Polyoma virus	6, 12, 18, and 24 months
<b>Immunofluorescence Assay</b>	
EDIM	6, 12, 18, and 24 months
LCM	6 and 12 months
MVM	18 and 24 months
Mouse adenoma virus	18 and 24 months

## RESULTS

Three rats had positive titers to *M. arthritidis* at the end of the 2-year study. Further evaluation of samples positive for *M. arthritidis* by immunoblot and Western blot procedures indicate that the positive titers may have been due to a cross reaction with antibodies of nonpathogenic *Mycoplasma* or other agents. Only sporadic samples were positive, and there were no clinical findings or histopathologic changes of *M. arthritidis* infection in rats with positive titers. Accordingly, *M. arthritidis*-positive titers were considered to be false positives.

**DEPARTMENT OF  
HEALTH & HUMAN SERVICES**

Public Health Service  
National Toxicology Program  
Central Data Management  
P.O. Box 12233, MD E1-02  
Research Triangle Park, NC 27709

**SPECIAL FOURTH-CLASS RATE  
POSTAGE AND FEES PAID  
DHHS/NIH  
Permit No. G-763**

**Official Business  
Penalty for Private Use - \$300**

**NIH Publication No. 96-3363  
April 1996**