

NTP TECHNICAL REPORT
ON THE
TOXICOLOGY AND CARCINOGENESIS
STUDIES OF
ISOBUTYRALDEHYDE
(CAS NO. 78-84-2)
IN F344/N RATS AND B6C3F₁ MICE
(INHALATION STUDIES)

February 1999

NATIONAL TOXICOLOGY PROGRAM
P.O. Box 12233
Research Triangle Park, NC 27709

NTP TR 472

NIH Publication No. 99-3962

U.S. DEPARTMENT OF HEALTH AND HUMAN SERVICES
Public Health Service
National Institutes of Health

FOREWORD

The National Toxicology Program (NTP) is made up of four charter agencies of the U.S. Department of Health and Human Services (DHHS): the National Cancer Institute (NCI), National Institutes of Health; the National Institute of Environmental Health Sciences (NIEHS), National Institutes of Health; the National Center for Toxicological Research (NCTR), Food and Drug Administration; and the National Institute for Occupational Safety and Health (NIOSH), Centers for Disease Control. In July 1981, the Carcinogenesis Bioassay Testing Program, NCI, was transferred to the NIEHS. The NTP coordinates the relevant programs, staff, and resources from these Public Health Service agencies relating to basic and applied research and to biological assay development and validation.

The NTP develops, evaluates, and disseminates scientific information about potentially toxic and hazardous chemicals. This knowledge is used for protecting the health of the American people and for the primary prevention of disease.

The studies described in this Technical Report were performed under the direction of the NIEHS and were conducted in compliance with NTP laboratory health and safety requirements and must meet or exceed all applicable federal, state, and local health and safety regulations. Animal care and use were in accordance with the Public Health Service Policy on Humane Care and Use of Animals. The prechronic and chronic studies were conducted in compliance with Food and Drug Administration (FDA) Good Laboratory Practice Regulations, and all aspects of the chronic studies were subjected to retrospective quality assurance audits before being presented for public review.

These studies are designed and conducted to characterize and evaluate the toxicologic potential, including carcinogenic activity, of selected chemicals in laboratory animals (usually two species, rats and mice). Chemicals selected for NTP toxicology and carcinogenesis studies are chosen primarily on the bases of human exposure, level of production, and chemical structure. The interpretive conclusions presented in this Technical Report are based only on the results of these NTP studies. Extrapolation of these results to other species and quantitative risk analyses for humans require wider analyses beyond the purview of these studies. Selection *per se* is not an indicator of a chemical's carcinogenic potential.

Listings of all published NTP reports and ongoing studies are available from NTP Central Data Management, NIEHS, P.O. Box 12233, MD E1-02, Research Triangle Park, NC 27709 (919-541-3419). The Abstracts and other study information for 2-year studies are also available at the NTP's World Wide Web site: <http://ntp-server.niehs.nih.gov>.

NTP TECHNICAL REPORT
ON THE
TOXICOLOGY AND CARCINOGENESIS
STUDIES OF
ISOBUTYRALDEHYDE
(CAS NO. 78-84-2)
IN F344/N RATS AND B6C3F₁ MICE
(INHALATION STUDIES)

February 1999

NATIONAL TOXICOLOGY PROGRAM
P.O. Box 12233
Research Triangle Park, NC 27709

NTP TR 472

NIH Publication No. 99-3962

U.S. DEPARTMENT OF HEALTH AND HUMAN SERVICES
Public Health Service
National Institutes of Health

CONTRIBUTORS

National Toxicology Program

Evaluated and interpreted results and reported findings

K.M. Abdo, Ph.D., Study Scientist
 D.A. Bridge, B.S.
 J.R. Bucher, Ph.D.
 R.E. Chapin, Ph.D.
 J.R. Hailey, D.V.M.
 J.K. Haseman, Ph.D.
 R.R. Maronpot, D.V.M.
 A. Nyska, D.V.M.
 G.N. Rao, D.V.M., Ph.D.
 J.H. Roycroft, Ph.D.
 C.S. Smith, Ph.D.
 G.S. Travlos, D.V.M.
 D.B. Walters, Ph.D.
 K.L. Witt, M.S., Oak Ridge Associated Universities

Litton Bionetics, Inc.

Conducted 13-week studies, evaluated pathology findings

B.J. Chou, D.V.M., Ph.D., Principal Investigator
 D. Craig, Ph.D.
 J.M. Fitzgerald, Ph.D.
 A.G. Manus, D.V.M.

Battelle Pacific Northwest Laboratories

Conducted 2-year studies, evaluated pathology findings

B.J. Chou, D.V.M., Ph.D., Principal Investigator
 A.W. Gieschen, B.S.
 S.L. Grumbein, D.V.M., Ph.D.
 T.J. Mast, Ph.D.
 R.A. Renne, D.V.M., Ph.D.

Experimental Pathology Laboratories, Inc.

Provided pathology quality assurance

J.F. Hardisty, D.V.M., Principal Investigator
 D. Banas, D.V.M., M.S.
 S. Botts, D.V.M., M.S., Ph.D.

NTP Pathology Working Group

*Evaluated slides, prepared pathology report on rats
 (29 May 1996)*

D.G. Goodman, V.M.D., Chairperson
 PATHCO, Inc.
 D. Banas, D.V.M., M.S.
 Experimental Pathology Laboratories, Inc.
 J.R. Hailey, D.V.M.
 National Toxicology Program
 R.A. Herbert, D.V.M., Ph.D.
 National Toxicology Program
 P. Little, D.V.M., M.S., Ph.D.
 Pathology Associates International
 A. Nyska, D.V.M.
 National Toxicology Program
 A. Radovsky, D.V.M., Ph.D.
 National Toxicology Program
 D. Wolf, D.V.M., Ph.D.
 Chemical Industry Institute of Toxicology

*Evaluated slides, prepared pathology report on mice
 (23 July 1996)*

L. Lanning, D.V.M., Chairperson
 Pathology Associates International
 S. Botts, D.V.M., M.S., Ph.D.
 Experimental Pathology Laboratories, Inc.
 J.R. Hailey, D.V.M.
 National Toxicology Program
 R.A. Herbert, D.V.M., Ph.D.
 National Toxicology Program
 J.R. Leininger, D.V.M., Ph.D.
 National Toxicology Program
 C. Merrill, D.V.M., Observer
 North Carolina State University
 A. Nyska, D.V.M.
 National Toxicology Program
 A. Radovsky, D.V.M., Ph.D.
 National Toxicology Program
 D. Wolf, D.V.M., Ph.D.
 Chemical Industry Institute of Toxicology

Dynamac Corporation

Prepared quality assurance audits

S. Brecher, Ph.D., Principal Investigator

Analytical Sciences, Inc.

Provided statistical analyses

R.W. Morris, M.S., Principal Investigator

S.R. Lloyd, M.S.

N.G. Mintz, B.S.

Biotechnical Services, Inc.

Prepared Technical Report

S.R. Gunnels, M.A., Principal Investigator

J.M. Gregory, B.S.

L.M. Harper, B.S.

A.M. Macri-Hanson, M.A., M.F.A.

S.M. Swift, B.S.

CONTENTS

ABSTRACT	5
EXPLANATION OF LEVELS OF EVIDENCE OF CARCINOGENIC ACTIVITY	9
TECHNICAL REPORTS REVIEW SUBCOMMITTEE	10
SUMMARY OF TECHNICAL REPORTS REVIEW SUBCOMMITTEE COMMENTS	11
INTRODUCTION	13
MATERIALS AND METHODS	17
RESULTS	27
DISCUSSION AND CONCLUSIONS	47
REFERENCES	51
APPENDIX A Summary of Lesions in Male Rats in the 2-Year Inhalation Study of Isobutyraldehyde	57
APPENDIX B Summary of Lesions in Female Rats in the 2-Year Inhalation Study of Isobutyraldehyde	89
APPENDIX C Summary of Lesions in Male Mice in the 2-Year Inhalation Study of Isobutyraldehyde	119
APPENDIX D Summary of Lesions in Female Mice in the 2-Year Inhalation Study of Isobutyraldehyde	151
APPENDIX E Genetic Toxicology	187
APPENDIX F Organ Weights and Organ-Weight-to-Body-Weight Ratios	207
APPENDIX G Hematology and Clinical Chemistry Results	211
APPENDIX H Reproductive Tissue Evaluations and Estrous Cycle Characterization	215
APPENDIX I Chemical Characterization and Generation of Chamber Concentrations	219
APPENDIX J Ingredients, Nutrient Composition, and Contaminant Levels in NIH-07 Rat and Mouse Ration	231
APPENDIX K Sentinel Animal Program	235

ABSTRACT

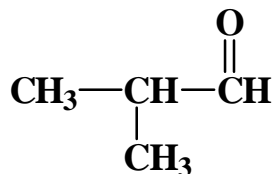

ISOBUTYRALDEHYDE

CAS No. 78-84-2

Chemical Formula: C₄H₈O Molecular Weight: 72.10

Synonyms: Dimethylacetaldehyde; 2-formylpropane; isobutanal; isobutylcarboxaldehyde; isobutyral; isobutyric aldehyde; isobutyrylaldehyde; isopropylformaldehyde; 2-methylpropanal; 2-methyl-1-propanal; α-methylpropionaldehyde; 2-methylpropionaldehyde; valine aldehyde

Isobutyraldehyde, a branched alkyl aldehyde, is used as a chemical intermediate and flavoring agent. It was nominated by the National Cancer Institute for toxicity and carcinogenicity studies by the NTP. Reasons for nomination and selection of isobutyraldehyde for study included its high potential for human exposure as suggested by its high production volume, its use as a chemical intermediate and food flavoring agent, suspicion of carcinogenicity due to an increased incidence of cancer at an aldehyde manufacturing plant where workers were exposed to a variety of aldehydes, its structural relationship to formaldehyde (a nasal carcinogen in rats), and the lack of toxicity and carcinogenicity studies on isobutyraldehyde in animals. Although human exposure occurs orally, dermally, or via inhalation, the inhalation route of exposure was selected for these animal studies because of the instability of isobutyraldehyde in water and feed. Male and female F344/N rats and B6C3F₁ mice were exposed to isobutyraldehyde (approximately 99% pure) by inhalation for 13 weeks or 2 years. Genetic toxicology studies were conducted *in vitro* in *Salmonella typhimurium*, L5178Y mouse lymphoma cells, and cultured Chinese hamster ovary cells; *in vivo* tests were conducted in *Drosophila*

melanogaster germ cells and bone marrow cells of rats and mice.

13-WEEK STUDY IN RATS

Groups of 10 male and 10 female F344/N rats were exposed to 0, 500, 1,000, 2,000, 4,000, or 8,000 ppm isobutyraldehyde by inhalation, 6 hours per day, 5 days a week, for 13 weeks. All rats exposed to 8,000 ppm died before the end of the study. Three male rats and six female rats in the 4,000 ppm groups and one female in the 500 ppm group died before the end of the study. The final mean body weight of male rats in the 4,000 ppm group and the body weight gains of 4,000 ppm males and females were significantly less than those of the chamber controls. Clinical findings in rats exposed to 4,000 or 8,000 ppm included abnormal respiratory sounds, decreased activity, nasal discharge, prostration, and slowed respiration. A minimal mature neutrophilia, evidenced by increased segmented neutrophil numbers, occurred in exposed groups of male and female rats. Exposure to isobutyraldehyde resulted in minimal increases in alanine aminotransferase activity in

all groups of male and female rats. Spermatozoal motility in 500 and 1,000 ppm males was significantly reduced and females exposed to 4,000 ppm differed significantly from the chamber control females in the relative time spent in the estrous stages.

No gross lesions were observed at necropsy that could be associated with isobutyraldehyde exposure. In the 8,000 ppm groups, severe necrosis of the epithelium, and occasionally of the entire mucosa, of the nasal turbinates accompanied by an acute inflammatory reaction was observed. Increased incidences of squamous metaplasia and mild acute inflammation occurred in male and female rats exposed to 4,000 ppm. Minimal to mild degeneration of the olfactory epithelium was observed in all male rats in the 2,000 and 4,000 ppm groups. Male rats exposed to 4,000 or 8,000 ppm and females exposed to 4,000 ppm had mild osteodystrophy of the turbinate bone. The incidences of necrosis/degeneration of the larynx and trachea were increased in male rats in the 8,000 ppm group. The incidences of mild to moderate lymphoid depletion of the spleen and thymus and lymphoid necrosis of the thymus were significantly increased in male and female rats exposed to 8,000 ppm.

13-WEEK STUDY IN MICE

Ten male and 10 female B6C3F₁ mice were exposed to 0, 500, 1,000, 2,000, 4,000, or 8,000 ppm isobutyraldehyde by inhalation, 6 hours per day, 5 days per week, for 13 weeks. One male in the chamber control group, one male in the 1,000 ppm group, nine males and all females in the 4,000 ppm groups, and all males and females in the 8,000 ppm groups died before the end of the study. The final mean body weight and body weight gain of female mice in the 1,000 ppm group were significantly less than those of the chamber controls. Clinical findings included decreased activity, tremors, prostration, and slower and labored respiration. The absolute and relative kidney weights of males in the 1,000 and 2,000 ppm groups were significantly increased.

There were no gross lesions observed at necropsy that could be associated with isobutyraldehyde exposure. Histopathologically, the nasal cavity and lymphopoietic tissues were considered target organs, with changes similar, but not identical, to those observed

in rats. Increased incidences of nonneoplastic lesions of the nasal cavity were observed in male and female mice exposed to 1,000 ppm or greater. These lesions included necrosis, inflammation, hyperplasia, and squamous metaplasia of the epithelium; serous and suppurative exudate within the nasal passages; olfactory epithelial degeneration; and osteodystrophy of the turbinate bone. Mild to moderate lymphoid depletion and/or lymphoid necrosis were observed in the thymus of male and female mice exposed to 8,000 ppm.

2-YEAR STUDY IN RATS

Groups of 50 male and 50 female F344/N rats were exposed to 0, 500, 1,000, or 2,000 ppm isobutyraldehyde by inhalation, 6 hours per day, 5 days per week, for 105 weeks.

Survival and Body Weights

No differences in survival rates between exposed and chamber control rats were found. The mean body weights of male and female rats were generally similar to those of the chamber controls throughout the study.

Pathology Findings

No increase in neoplasm incidences that could be attributed to exposure to isobutyraldehyde was observed in male or female rats. Nonneoplastic lesions related to isobutyraldehyde exposure were limited to the nose and consisted of squamous metaplasia of the respiratory epithelium, degeneration of the olfactory epithelium, and suppurative inflammation. Incidences of minimal to mild squamous metaplasia in 1,000 and 2,000 ppm males and females and in 500 ppm females were significantly greater than those in the chamber controls. Another lesion associated with isobutyraldehyde exposure was minimal to mild degeneration of the olfactory epithelium in 2,000 ppm males and females. The incidences of suppurative inflammation (rhinitis) in male and female rats exposed to 2,000 ppm were increased compared to the chamber controls.

2-YEAR STUDY IN MICE

Groups of 50 male and 50 female B6C3F₁ mice were exposed to 0, 500, 1,000, or 2,000 ppm

isobutyraldehyde by inhalation, 6 hours per day, 5 days per week, for 105 weeks.

Survival and Body Weights

There was an exposure-related decrease in survival of male mice, and the survival of males exposed to 2,000 ppm was marginally lower than that of the chamber controls. The mean body weights of female mice exposed to 1,000 or 2,000 ppm were lower than those of the chamber controls during the second year of the study.

Pathology Findings

No neoplasms that could be attributed to isobutyraldehyde exposure were observed in mice. Non-neoplastic lesions related to isobutyraldehyde exposure were limited to the nose. The incidences of olfactory epithelial degeneration in 1,000 and 2,000 ppm males and females were significantly greater than in the chamber controls.

GENETIC TOXICOLOGY

Isobutyraldehyde is mutagenic *in vitro* and *in vivo*, with the strongest responses observed in mammalian cell assays that measured chromosomal damage. Results of an initial mutagenicity test in *S. typhimurium* were negative; a second test, conducted with different strains and varying concentrations of induced S9 activation enzymes, gave equivocal results. Strongly positive responses were obtained in the mouse lymphoma assay for mutation induction in L5178Y cells without S9 and in cyto-

genetic tests for induction of sister chromatid exchanges and chromosomal aberrations in cultured Chinese hamster ovary cells. Sister chromatid exchanges were significantly increased with and without S9, but induction of chromosomal aberrations was noted unequivocally only in the absence of S9. No induction of sex-linked recessive lethal mutations was observed in germ cells of male *D. melanogaster* administered isobutyraldehyde by feeding or by injection.

In vivo, isobutyraldehyde was demonstrated to induce chromosomal aberrations in bone marrow cells of male mice, but no increases in micronuclei were observed in bone marrow cells of mice or rats after administration of isobutyraldehyde. All these *in vivo* cytogenetic studies used doses that reached lethality.

CONCLUSIONS

Under the conditions of these 2-year inhalation studies, there was *no evidence of carcinogenic activity** of isobutyraldehyde in male or female F344/N rats or male or female B6C3F₁ mice exposed to 500, 1,000, or 2,000 ppm.

In male and female rats, exposure to isobutyraldehyde induced squamous metaplasia and suppurative inflammation of the nasal respiratory epithelium and degeneration of the nasal olfactory epithelium. In male and female mice, exposure to isobutyraldehyde caused degeneration of the nasal olfactory epithelium.

* Explanation of Levels of Evidence of Carcinogenic Activity is on page 9. A summary of the Technical Reports Review Subcommittee comments and the public discussion on this Technical Report appears on page 11.

Summary of the 2-Year Carcinogenesis and Genetic Toxicology Studies of Isobutyraldehyde

	Male F344/N Rats	Female F344/N Rats	Male B6C3F ₁ Mice	Female B6C3F ₁ Mice
Concentrations in air	Chamber control, 500, 1,000, or 2,000 ppm	Chamber control, 500, 1,000, or 2,000 ppm	Chamber control, 500, 1,000, or 2,000 ppm	Chamber control, 500, 1,000, or 2,000 ppm
Body weights	Exposed groups similar to chamber control groups	Exposed groups similar to chamber control groups	Exposed groups similar to chamber control groups	1,000 and 2,000 ppm groups less than chamber control groups
Survival rates	12/50, 15/50, 11/50, 10/50	27/50, 24/50, 24/50, 32/50	40/50, 37/50, 35/50, 30/50	28/50, 32/50, 36/50, 37/50
Nonneoplastic effects	<u>Nose:</u> respiratory epithelium squamous metaplasia (1/50, 1/49, 10/49, 44/50); suppurative inflammation (5/50, 3/49, 6/49, 15/50); olfactory epithelium degeneration (0/50, 0/49, 3/49, 44/50)	<u>Nose:</u> respiratory epithelium squamous metaplasia (1/49, 11/50, 9/49, 44/50); suppurative inflammation (2/49, 3/50, 5/49, 11/50); olfactory epithelium degeneration (0/49, 0/50, 2/49, 45/50)	<u>Nose:</u> olfactory epithelium degeneration (0/50, 0/50, 11/50, 45/50)	<u>Nose:</u> olfactory epithelium degeneration (1/50, 1/50, 27/50, 49/50)
Neoplastic effects	None	None	None	None
Level of evidence of carcinogenic activity	No evidence	No evidence	No evidence	No evidence
Genetic toxicology	<i>Salmonella typhimurium</i> gene mutations: Negative in strains TA97, TA98, TA100, TA102, TA1535, and TA1537 with and without S9; equivocal in strain TA104 with S9 Positive without S9 Mouse lymphoma gene mutations: Positive with and without S9 Sister chromatid exchanges: Positive without S9 Cultured Chinese hamster ovary cells <i>in vitro</i> : Positive Chromosomal aberrations: Positive without S9 Cultured Chinese hamster ovary cells <i>in vitro</i> : Positive Mouse bone marrow <i>in vivo</i> : Negative Sex-linked recessive lethal mutations: Negative <i>Drosophila melanogaster</i> : Negative Micronucleated erythrocytes: Negative Mouse bone marrow <i>in vivo</i> : Negative Rat bone marrow <i>in vivo</i> : Negative			

EXPLANATION OF LEVELS OF EVIDENCE OF CARCINOGENIC ACTIVITY

The National Toxicology Program describes the results of individual experiments on a chemical agent and notes the strength of the evidence for conclusions regarding each study. Negative results, in which the study animals do not have a greater incidence of neoplasia than control animals, do not necessarily mean that a chemical is not a carcinogen, inasmuch as the experiments are conducted under a limited set of conditions. Positive results demonstrate that a chemical is carcinogenic for laboratory animals under the conditions of the study and indicate that exposure to the chemical has the potential for hazard to humans. Other organizations, such as the International Agency for Research on Cancer, assign a strength of evidence for conclusions based on an examination of all available evidence, including animal studies such as those conducted by the NTP, epidemiologic studies, and estimates of exposure. Thus, the actual determination of risk to humans from chemicals found to be carcinogenic in laboratory animals requires a wider analysis that extends beyond the purview of these studies.

Five categories of evidence of carcinogenic activity are used in the Technical Report series to summarize the strength of the evidence observed in each experiment: two categories for positive results (**clear evidence** and **some evidence**); one category for uncertain findings (**equivocal evidence**); one category for no observable effects (**no evidence**); and one category for experiments that cannot be evaluated because of major flaws (**inadequate study**). These categories of interpretative conclusions were first adopted in June 1983 and then revised in March 1986 for use in the Technical Report series to incorporate more specifically the concept of actual weight of evidence of carcinogenic activity. For each separate experiment (male rats, female rats, male mice, female mice), one of the following five categories is selected to describe the findings. These categories refer to the strength of the experimental evidence and not to potency or mechanism.

- **Clear evidence** of carcinogenic activity is demonstrated by studies that are interpreted as showing a dose-related (i) increase of malignant neoplasms, (ii) increase of a combination of malignant and benign neoplasms, or (iii) marked increase of benign neoplasms if there is an indication from this or other studies of the ability of such tumors to progress to malignancy.
- **Some evidence** of carcinogenic activity is demonstrated by studies that are interpreted as showing a chemical-related increased incidence of neoplasms (malignant, benign, or combined) in which the strength of the response is less than that required for clear evidence.
- **Equivocal evidence** of carcinogenic activity is demonstrated by studies that are interpreted as showing a marginal increase of neoplasms that may be chemical related.
- **No evidence** of carcinogenic activity is demonstrated by studies that are interpreted as showing no chemical-related increases in malignant or benign neoplasms.
- **Inadequate study** of carcinogenic activity is demonstrated by studies that, because of major qualitative or quantitative limitations, cannot be interpreted as valid for showing either the presence or absence of carcinogenic activity.

When a conclusion statement for a particular experiment is selected, consideration must be given to key factors that would extend the actual boundary of an individual category of evidence. Such consideration should allow for incorporation of scientific experience and current understanding of long-term carcinogenesis studies in laboratory animals, especially for those evaluations that may be on the borderline between two adjacent levels. These considerations should include:

- adequacy of the experimental design and conduct;
- occurrence of common versus uncommon neoplasia;
- progression (or lack thereof) from benign to malignant neoplasia as well as from preneoplastic to neoplastic lesions;
- some benign neoplasms have the capacity to regress but others (of the same morphologic type) progress. At present, it is impossible to identify the difference. Therefore, where progression is known to be a possibility, the most prudent course is to assume that benign neoplasms of those types have the potential to become malignant;
- combining benign and malignant tumor incidence known or thought to represent stages of progression in the same organ or tissue;
- latency in tumor induction;
- multiplicity in site-specific neoplasia;
- metastases;
- supporting information from proliferative lesions (hyperplasia) in the same site of neoplasia or in other experiments (same lesion in another sex or species);
- presence or absence of dose relationships;
- statistical significance of the observed tumor increase;
- concurrent control tumor incidence as well as the historical control rate and variability for a specific neoplasm;
- survival-adjusted analyses and false positive or false negative concerns;
- structure-activity correlations; and
- in some cases, genetic toxicology.

**NATIONAL TOXICOLOGY PROGRAM BOARD OF SCIENTIFIC COUNSELORS
TECHNICAL REPORTS REVIEW SUBCOMMITTEE**

The members of the Technical Reports Review Subcommittee who evaluated the draft NTP Technical Report on isobutyraldehyde on 12 December 1996 are listed below. Subcommittee members serve as independent scientists, not as representatives of any institution, company, or governmental agency. In this capacity, subcommittee members have five major responsibilities in reviewing the NTP studies:

- to ascertain that all relevant literature data have been adequately cited and interpreted,
- to determine if the design and conditions of the NTP studies were appropriate,
- to ensure that the Technical Report presents the experimental results and conclusions fully and clearly,
- to judge the significance of the experimental results by scientific criteria, and
- to assess the evaluation of the evidence of carcinogenic activity and other observed toxic responses.

Gary P. Carlson, Ph.D., Chairperson
School of Health Sciences
Purdue University
West Lafayette, IN

Irma Russo, M.D.
Fox Chase Cancer Center
Philadelphia, PA

Arnold L. Brown, M.D., Principal Reviewer
University of Wisconsin Medical School
Madison, WI

Louise Ryan, Ph.D.
Division of Biostatistics
Dana-Farber Cancer Institute
Boston, MA

Thomas L. Goldsworthy, Ph.D.
Department of Experimental Pathology and Toxicology
Chemical Industry Institute of Toxicology
Research Triangle Park, NC

Robert E. Taylor, M.D., Ph.D.
Department of Pharmacology
Howard University College of Medicine
Washington, DC

Robert LeBoeuf, Ph.D.
Corporate Professional and Regulatory Services
Human Safety Department
The Procter & Gamble Company
Cincinnati, OH

Frederick L. Tyson, Ph.D., Principal Reviewer
St. Mary's Hospital and Medical Center
Cancer Research Institute
Grand Junction, CO

Janardan K. Reddy, M.D.
Department of Pathology
Northwestern University Medical School
Chicago, IL

Jerrold M. Ward, D.V.M., Ph.D.*
National Cancer Institute
Frederick, MD

* Did not attend

SUMMARY OF TECHNICAL REPORTS REVIEW SUBCOMMITTEE COMMENTS

On 12 December 1996, the draft Technical Report on the toxicology and carcinogenesis studies of isobutyraldehyde received public review by the National Toxicology Program's Board of Scientific Counselors' Technical Reports Review Subcommittee. The review meeting was held at the National Institute of Environmental Health Sciences, Research Triangle Park, NC.

Dr. K.M. Abdo, NIEHS, introduced the toxicology and carcinogenesis studies of isobutyraldehyde by discussing the uses of the chemical and the rationale for study, describing the experimental design, reporting on survival and body weight effects, and commenting on compound-related nonneoplastic lesions in rats and mice. The proposed conclusions for the 2-year studies were *no evidence of carcinogenic activity* in male or female F344/N rats or B6C3F₁ mice.

Dr. Tyson, a principal reviewer, agreed with the proposed conclusions. He suggested adding a discussion of the possible reasons for the discrepancy between genotoxicity reported in previous studies and the NTP studies (page 50).

Dr. Brown, the second principal reviewer, agreed with the proposed conclusions. He suggested that the portion of the Results section regarding the insignificance of the nasal tumors found in rats be included in the Discussion and Conclusions section in view of the rarity of nasal neoplasms of any kind. Dr. Brown acknowledged the appropriateness of the inhalation route. He also noted that significant human exposure can occur from food or water and that a comment on the natural availability of the compound would be helpful. Dr. Abdo replied that when added to food or water, the chemical is conjugated by or combines with other chemicals and some degradation of the isobutyraldehyde is observed. Further, he added, isobutyraldehyde was nominated for study due to concerns of worker exposure to the chemical.

Dr. Tyson moved that the Technical Report on isobutyraldehyde be accepted with the revisions discussed and the conclusions as written for male and female rats and mice, *no evidence of carcinogenic activity*. Dr. Brown seconded the motion, which was accepted unanimously with eight votes.

INTRODUCTION

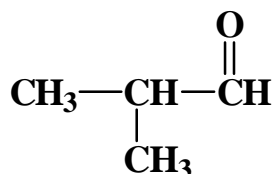

ISOBUTYRALDEHYDE

CAS No. 78-84-2

Chemical Formula: C₄H₈O Molecular Weight: 72.10

Synonyms: Dimethylacetaldehyde; 2-formylpropane; isobutanal; isobutylcarboxaldehyde; isobutyral; isobutyric aldehyde; isobutyrylaldehyde; isopropylformaldehyde; 2-methylpropanal; 2-methyl-1-propanal; α-methylpropionaldehyde; 2-methylpropionaldehyde; valine aldehyde

CHEMICAL AND PHYSICAL PROPERTIES

Isobutyraldehyde is a clear, colorless liquid with a pungent odor and a fruity taste (*Hawley's*, 1987). It has a melting point of -65.9° C, a boiling point of 64° C at 760 mm Hg, and a density of 0.7938 at 20° C (*Merck Index*, 1989). Isobutyraldehyde has a vapor pressure of 173 mm Hg at 25° C (Daubert and Danner, 1989), a vapor density of 2.48, and a conversion factor of 1 ppm equivalent to 2.9 mg/m³ (*Patty's*, 1963). It is soluble in water (11 g/100 mL) at 20° C and miscible with ethanol, ether, carbon disulfide, acetone, benzene, toluene, and chloroform (*Merck Index*, 1989).

PRODUCTION, USE, AND HUMAN EXPOSURE

There are at least two methods for the manufacture of isobutyraldehyde: reaction of propylene, carbon monoxide, and hydrogen at 130° to 160° C and 1,500 to 3,000 psi (*Merck Index*, 1989) and oxidation of isobutyl alcohol with potassium dichromate and concentrated sulfuric acid (*Fenaroli's*, 1975).

The total United States consumption of isobutyraldehyde is steadily increasing. The consumption

figures were 307, 449, 482, and 515 million pounds in 1980, 1987, 1990, and 1993, respectively. The projected consumption for 1998 is 579 million pounds (*Chemical Economics Handbook*, 1996).

Isobutyraldehyde is used in the synthesis of products such as isobutanol, neopentyl glycol, isobutyl acetate, isobutyric acid, isobutylidene diurea, and methyl isoamyl ketone (*Chemical Economics Handbook*, 1996). It is also used for the synthesis of the amino acids valine and leucine, pantothenic acid, cellulose esters, perfumes, plasticizers, resins, flavoring agents, and gasoline additives (*Merck Index*, 1989) as well as in the synthesis of rubber antioxidants and accelerators (*Hawley's*, 1987).

Isobutyraldehyde is a natural constituent of many foods. It is present in beans, beef fat, black currants, bread, brussels sprouts, butter, carrots, cauliflower, celery, cheese, cocoa beans, coconut, coffee, lettuce, peanuts, potatoes, rum, soy beans, soy sauce, tea, tomatoes, whisky, and wine (Food Chemical Codex, 1972). Reported average concentrations of isobutyraldehyde range from 5.0 ppm in alcoholic beverages to 0.5 to 1.0 ppm in baked goods, 0.67 ppm in candy, 0.25 to 0.50 ppm in ice cream, and 0.3 ppm in nonalcoholic beverages (*Fenaroli's*, 1975).

Isobutyraldehyde is present in the environment. It is emitted into the atmosphere by combustion of gasoline, diesel fuel, and wood. Other environmental sources of this chemical include animal wastes, microbes, and vegetation (Graedel *et al.*, 1986). Isobutyraldehyde is formed in drinking water as a result of oxidation of naturally occurring amino acids during chlorination (Hrudey *et al.*, 1988).

Human exposure to isobutyraldehyde is widespread. Significant exposure occurs in the general population through consumption of food and water (Fenaroli's, 1975; Hrudey *et al.*, 1988). Occupational exposure occurs through inhalation and dermal contact. The National Occupational Exposure Survey estimated that during 1981 through 1983, approximately 4,114 workers were occupationally exposed to isobutyraldehyde (NIOSH, 1990).

REGULATORY STATUS

Isobutyraldehyde is approved by the Food and Drug Administration for use as a flavoring agent in foods (21 CFR, § 172.515). Isobutyraldehyde is on the list of toxic chemicals (40 CFR, § 372.65) subject to reporting since January 1, 1987, under Section 313 of the Emergency Planning and Community Right-to-Know Act of 1986, also known as Title III of the Superfund Amendments and Reauthorization Act of 1986 (40 CFR, § 350.1). No occupational exposure limits have been set for isobutyraldehyde in the United States; however, a short-term exposure limit of 5 mg/m³ has been set by the Commonwealth of Independent States (Sittig, 1994).

ABSORPTION, DISTRIBUTION, METABOLISM, AND EXCRETION

Experimental Animals

Very little specific information on the disposition and metabolism of isobutyraldehyde is available. Because isobutyraldehyde is a branched alkyl aldehyde, it is unlikely that it undergoes β -oxidation and therefore it may be excreted either unchanged or as a conjugated acid (Williams, 1959; Brabec, 1981). The reaction of aldehydes with glutathione produces thiohemiacetals. Glutathione condensation products have been isolated from the urine of animals fed acrolein or chloroethanol (Brabec, 1981). Isobutyraldehyde showed little oxidation by rat liver mitochondria (Smith and

Packer, 1972). In *in vitro* studies, isobutyraldehyde was shown to undergo oxidative deformylation catalyzed by rabbit liver cytochrome P₄₅₀ enzymes yielding propylene and formic acid (Roberts *et al.*, 1991). This reaction was found to be dependent on NADPH, molecular oxygen, P₄₅₀, and NADPH-ferrihemoprotein reduction.

TOXICITY

The LC₅₀ values for isobutyraldehyde are 60,000 ppm after 30 minutes of inhalation exposure for rats and 13,860 ppm after 2-hour inhalation exposure for mice (Zolotov and Svintukhovskii, 1972; RTECS, 1982). The oral LD₅₀ for rats is 960 mg isobutyraldehyde per kg body weight (Zolotov and Svintukhovskii, 1972). Reported signs of acute toxicity of isobutyraldehyde include irritation of the skin, eyes, and respiratory tract (Marhold, 1986). Isobutyraldehyde administered either orally, intraperitoneally, or by inhalation to rats caused lung damage and necrosis of the gastrointestinal tract (Svintukhovskii, 1972).

Isobutyraldehyde was tested on female B6C3F₁ mice by the NTP (1990) for irritancy and contact hypersensitivity. The doses of isobutyraldehyde ranged from 3% to 30% in a solution of four parts acetone to one part olive oil for sensitization tests and 30% for challenge tests. Mice received 20 mL isobutyraldehyde applied directly to shaved and abraded ears for 5 consecutive days with and without adjuvant. No indication of irritation or hypersensitivity was observed.

CARCINOGENICITY

Experimental Animals

No information on carcinogenicity of isobutyraldehyde in animals was found in the literature. Formaldehyde (a structurally related chemical) was administered by inhalation 6 hours per day, 5 days a week, for 24 months. It was found to be carcinogenic in male and female F344 rats, causing increased incidences of nasal squamous cell carcinoma, but it was not carcinogenic in male and female B6C3F₁ mice (Kerns *et al.*, 1983a). The concentration- and species-dependent nature of this observation was related to the difference in deposition of formaldehyde administered by inhalation in the nasal cavity of these strains of rats and mice (Chang *et al.*, 1983). Mice

had reduced deposition due to their decreased ventilation upon repeated exposure. The differences in nasal cavity deposition and in elimination of absorbed formaldehyde was thought to contribute to differences in formaldehyde-induced DNA-protein cross-linking between species (Heck *et al.*, 1989; Casanova *et al.*, 1991). The reduced deposition of formaldehyde was shown to be associated with a decrease in nasal cell proliferation. The oxidation of aldehydes by NAD⁺-dependent dehydrogenases in the rat mucosa may play a protective role in aldehyde exposures (Casanova-Schmitz *et al.*, 1984).

Humans

The potential for carcinogenicity of aldehydes was recognized when Bittersohl (1974) reported that workers in an aldehyde factory producing aldol, crotonaldehyde, acetaldehyde, and butyraldehyde experienced a malignancy rate greater than expected when compared to age-matched controls. It was speculated that aldehydes and possibly smoking contributed to the increased malignancy.

GENETIC TOXICITY

There are little published mutagenicity data for isobutyraldehyde. The few studies found in the literature provide little evidence for genotoxic potential. No mutagenic activity was detected for isobutyraldehyde over a broad range of concentrations in any of several strains of *Salmonella typhimurium* (Sasaki and Endo, 1978; Florin *et al.*, 1980; Mortelmans *et al.*, 1986). Additionally, no evidence of sister chromatid

exchange induction, a measure of DNA damage, was noted in human lymphocyte cultures exposed to isobutyraldehyde *in vitro* (Obe and Beek, 1979), and no induction of sex-linked recessive lethal mutations was observed in germ cells of male *Drosophila melanogaster* administered isobutyraldehyde by feeding or injection (Woodruff *et al.*, 1985). The negative results noted in these published studies contrast with the strong evidence for clastogenicity of isobutyraldehyde in NTP tests for induction of chromosomal aberrations in mammalian cells *in vitro* and *in vivo* (Appendix E).

STUDY RATIONALE

Isobutyraldehyde, a branched alkyl aldehyde, was nominated by the National Cancer Institute for toxicity and carcinogenicity testing by the NTP. Reasons for nomination and selection of isobutyraldehyde for study included its high potential for human exposure as suggested by its high production volume, its use as a chemical intermediate and food flavoring agent, suspicion of carcinogenicity due to an increased incidence of cancer at an aldehyde manufacturing plant where workers were exposed to a variety of aldehydes, its structural relationship to formaldehyde (a nasal carcinogen in rats), and the lack of toxicity and carcinogenicity studies on isobutyraldehyde in animals. Although human exposure occurs orally, dermally, or via inhalation, the inhalation route of exposure was selected for these animal studies because of the instability of isobutyraldehyde in water and feed.

MATERIALS AND METHODS

PROCUREMENT AND CHARACTERIZATION OF ISOBUTYRALDEHYDE

Isobutyraldehyde was obtained from Eastman Chemical Company (Tennessee Eastman Division, Kingsport, TN, 13-week studies; Texas Eastman Division, Longview, TX, 2-year studies) in three lots. Lots 56-202 and E042283 were used during the 13-week studies, and lot E080289 was used during the 2-year studies. Identity, purity, and stability analyses were conducted by the analytical chemistry laboratory, Midwest Research Institute (Kansas City, MO) (Appendix I). Reports on analyses performed in support of the isobutyraldehyde studies are on file at the National Institute of Environmental Health Sciences.

All lots of the chemical, a clear, colorless, nonviscous liquid, were identified as isobutyraldehyde by infrared, ultraviolet/visible, and nuclear magnetic resonance spectroscopy. The purity of each lot was determined by elemental analyses, Karl Fischer water analysis, oximation and free acid titration, and gas chromatography by two systems. For lot 56-202, elemental analyses for carbon and hydrogen were in agreement with the theoretical values for isobutyraldehyde. Karl Fischer water analysis indicated $0.11\% \pm 0.01\%$ water. Functional group titration for oximation indicated a purity of $102.0\% \pm 0.9\%$, and functional group titration for free acid indicated a concentration of $0.375\% \pm 0.008\%$ isobutyric acid (a common oxidation product of isobutyraldehyde). Gas chromatography of lot 56-202 by one system indicated one major peak and three impurities with areas greater than 0.1% of the major peak area. Two impurities had a combined area of 0.20% relative to the major peak area; the third impurity had an area of 0.46% relative to the major peak area and was identified as isobutyric acid by spiking with a standard solution of isobutyric acid in toluene. Gas chromatography by a second system indicated one major peak and four impurities with areas greater than 0.1% of the major peak area. One impurity had an area of 0.29% relative to the major peak area; the remaining

three impurities had a combined area of 0.57% relative to the major peak area. The overall purity of lot 56-202 was determined to be approximately 99%.

For lot E042283, elemental analyses for carbon and hydrogen were in agreement with the theoretical values for isobutyraldehyde. Karl Fischer water analysis indicated $0.084\% \pm 0.007\%$ water. Functional group titration for oximation indicated a purity of $99.1\% \pm 0.9\%$, and functional group titration for free acid indicated a concentration of $0.32\% \pm 0.01\%$ isobutyric acid. Gas chromatography of lot E042283 by one system indicated one major peak and four impurities with areas greater than 0.1% of the major peak area; the total area of the impurities was 0.68% relative to the major peak area. Gas chromatography by a second system indicated one major peak and three impurities with a total area of 0.63% relative to the major peak area. The overall purity of lot E042283 was determined to be approximately 99%.

For lot E080289, elemental analysis for hydrogen was in agreement with the theoretical value for isobutyraldehyde; the results for carbon were slightly low. Karl Fischer water analysis indicated $0.06\% \pm 0.01\%$ water. Oximation titration indicated a purity of $98.6\% \pm 0.5\%$, and functional group titration for free acid indicated a concentration of $0.79\% \pm 0.04\%$ isobutyric acid. Gas chromatography of lot E080289 by one system indicated one major peak and two impurities with a combined area of 0.7% relative to the major peak area. Gas chromatography of lot E080289 by a second system indicated one major peak and five impurities with a combined area of 1.4% relative to the major peak area. The overall purity of lot E080289 was determined to be approximately 98%.

Analysis for free isobutyric acid was conducted by the analytical chemistry laboratory with gas chromatography. The content of isobutyric acid in lots 56-202, E042283, and E080289 was $0.53\% \pm 0.04\%$, $0.70\% \pm 0.02\%$, and $1.40\% \pm 0.04\%$, respectively.

Stability studies of the bulk chemical were performed by the analytical chemistry laboratory using gas chromatography. These studies indicated that isobutyraldehyde was stable as a bulk chemical for 2 weeks when stored under a nitrogen headspace, protected from light, at temperatures up to 25° C. To ensure stability, the bulk chemical was stored at 4° C (13-week studies) or at room temperature (2-year studies) in the original containers under a nitrogen headspace. Stability was monitored throughout the 13-week and 2-year studies using titration of acidic compounds and gas chromatography. No degradation of the bulk chemical was detected.

VAPOR GENERATION AND EXPOSURE SYSTEM

Because isobutyraldehyde is a liquid with a high vapor pressure, the vapor for the 13-week studies was generated by bubbling nitrogen gas through a column of the liquid maintained at a constant temperature in a water bath. During the 13-week studies, the bubbler was continuously refilled via a side tube and pressure stopcock to maintain a constant isobutyraldehyde liquid level in the bubbler. Because isobutyraldehyde reacted with the copper tubing during a previous study, the system was redesigned for the 13-week studies. The copper tubing was replaced with stainless steel valves, connections, and tubing, and dilution air was added to the nitrogen-borne isobutyraldehyde vapor immediately above the bubbler to prevent condensation of isobutyraldehyde in the manifold or delivery lines when it cooled to room temperature. Concentrations of isobutyraldehyde vapor were adjusted for the individual exposure chambers by altering either the nitrogen flow rate, the exposure chamber air flow rate, or the water bath temperature.

Inhalation chambers of the Rochester design were used in the 13-week studies. The total volume for each chamber was 1.15 m³. The chamber ventilation system provided 12 to 15 charcoal- and HEPA-filtered air changes per hour, and the internal design of the chamber afforded equal exposure to each animal. This flow rate was sufficient to maintain proper temperature and humidity, provide a uniform and reproducible test atmosphere, and remove ammonia. The study laboratory designed the stainless-steel chambers used for the 2-year studies so that uniform

vapor concentrations could be maintained throughout the chamber when catch pans were in position. The total volume for each chamber was 2.3 m³; the active mixing volume of each chamber was 1.7 m³. A small particle detector (Type CN, Gardner Associates, Schenectady, NY) was used with and without animals in the exposure chambers to ensure that isobutyraldehyde vapor, and not aerosol, was produced. No particle counts above the minimum resolvable level (approximately 200 particles/cm³) were detected.

VAPOR CONCENTRATION MONITORING

The chamber concentrations of isobutyraldehyde in the 13-week studies were monitored on a Wilkes Model 80 infrared spectrophotometer. Samples were drawn and analyzed from each exposure chamber, the control chamber, and the exposure suite 6 to 14 times per exposure period during the 13-week studies. During the 13-week studies, samples were drawn through Teflon® tubing. Chamber concentrations of isobutyraldehyde in the 2-year study were monitored with an on-line gas chromatograph (Hewlett-Packard Model 5840, Palo Alto, CA). Samples were drawn and analyzed from each exposure chamber four times per hour using an 8-port stream-select valve. Calibration of the gas chromatograph monitoring the exposure chamber was achieved by independent quantitative analysis of grab samples collected with bubblers containing dimethylformamide and an internal standard. Additionally, the gas chromatograph was calibrated by a comparison of grab samples and gravimetrically prepared standards with an off-line gas chromatograph. The off-line gas chromatograph was calibrated with gravimetrically prepared standards of isobutyraldehyde in dimethylformamide.

CHAMBER ATMOSPHERE CHARACTERIZATION

The times for the chamber concentrations to build up to 90% of the final exposure concentrations (T₉₀) and to decay to 10% of the exposure concentrations (T₁₀) were measured in the 2-year studies with and without animals present in the chambers. At a chamber airflow rate of 15 air changes per hour, the theoretical value for both T₉₀ and T₁₀ is approximately 12 to 13 minutes; the T₉₀ value chosen for all studies was

12 minutes. The uniformity of isobutyraldehyde concentrations in the exposure chambers was measured before the 2-year studies began and approximately every 3 months during the 2-year studies. Uniformity of exposure concentrations in all chambers was acceptable. The persistence of isobutyraldehyde in the 2,000 ppm exposure chamber after shutting off the system was monitored during the 2-year studies, with and without animals present. The concentration of isobutyraldehyde in the exposure chambers fell to less than 1% of the beginning concentration within less than 30 minutes in all cases.

During the 13-week studies, generator reservoir and exposure chamber samples were monitored for isobutyric acid by gas chromatography. By determination of peak area ratios, the average ratio of isobutyric acid to isobutyraldehyde was 1.16% pregeneration and 2.54% postgeneration. Gas chromatography of postgeneration isobutyraldehyde samples with an internal standard of isobutyric acid revealed an isobutyric acid content of 7% to 12% in the reservoir. Chamber samples drawn on 2 days had no measurable amount of acid (less than 0.4% to 0.6% isobutyric acid/aldehyde). Before the 2-year studies began, the analytical chemistry laboratory tested the vapor stability of lot MH3821JH (not used for animal exposures). Results indicated less than 10% decomposition of isobutyraldehyde samples exposed for 4 hours to air and light; samples stored open to air and light for up to 24 hours showed a 35% to 40% loss of isobutyraldehyde, with approximately 15% accounted for as isobutyric acid. During the 2-year studies, isobutyraldehyde again was monitored for stability in the generator reservoir, generator evaporation flask, and exposure chambers by gas chromatography. A sample that remained in the generator reservoir for 7 days had a relative purity of 101% compared to a sample drawn from the reservoir immediately after it had been filled. By major peak comparison, the relative purity of the isobutyraldehyde in the generator flask at the end of the exposure day was determined to be 82.7% when compared to the material drawn from the generator flask at the beginning of the exposure day. Because isobutyraldehyde readily polymerizes to trimers, isobutyraldehyde samples were analyzed for polymers by gas chromatography/mass spectrometry. The amount of isobutyraldehyde converted to polymer in the generator flask at the beginning of the exposure day was determined to be 0.4%; at the end of the day,

5.9% polymer was found in the generator flask. No polymers were found in the distribution lines or in the 500 ppm or 2,000 ppm chambers before or after the exposure day.

Volatile degradation products and semivolatile impurities in the generator reservoir and exposure chambers in the 2-year studies were monitored with gas chromatography. Samples of isobutyraldehyde were collected from the generator reservoir at the beginning and end of the exposure day. Methane, propionaldehyde, and four unknown impurities were detected in various exposure system samples. Methane and propionaldehyde were detected in all generator flask samples and in the exposure chamber samples. All other measurements of identified and unidentified impurities were less than 0.1% by peak area relative to that of isobutyraldehyde in all samples. Propionaldehyde, butyraldehyde, and an unidentified impurity were detected in samples from the generator reservoir and from the distribution lines. No impurities were noted in the 500 ppm or 2,000 ppm chamber samples.

The concentration of isobutyric acid was analyzed with gas chromatography/mass spectroscopy. Samples from the bulk chemical, evaporation flask, 500 and 2,000 ppm chambers, and distribution lines were analyzed. The amount of isobutyric acid in the bulk material was 0.13% by weight as compared to isobutyraldehyde. The amount of isobutyric acid in the generation flask before exposure was 0.24% that of isobutyraldehyde by weight; after 6 hours of exposure, the concentration was 1.15% compared to isobutyraldehyde by weight. No isobutyric acid was detected in the distribution lines or in the exposure chambers; based on detection limits, the amount of isobutyric acid was less than 0.02% the amount of isobutyraldehyde in the distribution lines, less than 0.7% in the 500 ppm chambers, and less than 0.6% in the 2,000 ppm chambers.

13-WEEK STUDIES

The 13-week studies were conducted to evaluate the cumulative toxic effects of repeated exposure to isobutyraldehyde and to determine the appropriate exposure concentrations to be used in the 2-year studies.

Male and female F344/N rats and B6C3F₁ mice were obtained from the Frederick Cancer Research Facility (Frederick, MD). On receipt, the rats and mice were

4 weeks old. Animals were quarantined for 13 days and were 6 weeks old on the first day of the studies. Before initiation of the studies, five male and five female rats and mice were randomly selected for parasite evaluation and gross observation for evidence of disease. At the end of the studies, serologic analyses were performed on 10 male and 10 female control rats and mice using the protocols of the NTP Sentinel Animal Program (Appendix K).

Groups of 10 male and 10 female rats and mice were exposed to isobutyraldehyde at concentrations of 0, 500, 1,000, 2,000, 4,000, or 8,000 ppm for 6 hours plus T_{90} (12 minutes) per day, 5 days per week, for 13 weeks. Water was available *ad libitum*; feed was available *ad libitum* except during exposure periods. Rats and mice were housed individually. Clinical findings were recorded once weekly for rats and mice. The animals were weighed initially, weekly, and at the end of the studies. Details of the study design and animal maintenance are summarized in Table 1.

At the end of the 13-week studies, blood was collected by cardiac puncture from all rats for hematology and clinical chemistry analyses and from all mice for hematology analyses. Differential leukocyte counts, morphologic evaluation of blood cells, and reticulocyte counts were determined by light microscopic examination of blood films stained with Wright's, Giemsa, or Wright-Giemsa. The hematology and clinical chemistry parameters measured are listed in Table 1.

At the end of the 13-week studies, samples were collected for sperm morphology and vaginal cytology evaluations on male and female rats and male mice exposed to 0, 500, 1,000, 2,000, or 4,000 ppm and female mice exposed 0, 500, 1,000, or 2,000 ppm. The parameters evaluated are listed in Table 1. Methods used were those described in the NTP's sperm morphology and vaginal cytology evaluations protocol (NTP, 1983). For 12 consecutive days prior to scheduled terminal sacrifice, the vaginal vaults of the females were moistened with saline, if necessary, and samples of vaginal fluid and cells were stained. Relative numbers of leukocytes, nucleated epithelial cells, and large squamous epithelial cells were determined and used to ascertain estrous cycle stage (i.e., diestrus, proestrus, estrus, and metestrus). Male animals were evaluated for sperm morphology, concentration, and motility. The right testis and right

epididymis were isolated and weighed. The tail of the epididymis (cauda epididymis) was then removed from the epididymal body (corpus epididymis) and weighed. Test yolk (rats) or modified Tyrode's buffer (mice) was applied to slides, and a small incision was made at the distal border of the cauda epididymis. The sperm effluxing from the incision were dispersed in the buffer on the slides, and the numbers of motile and nonmotile spermatozoa were counted for five fields per slide by two observers. Following completion of sperm motility estimates, each right cauda epididymis was placed in buffered saline solution. Caudae were finely minced, and the tissue was incubated in the saline solution and then heat fixed at 65° C. Sperm density was then determined microscopically with the aid of a hemacytometer. Four sperm morphology slides were prepared for each animal evaluated. An aliquot of killed sperm suspension was stained in a test tube, spread on a microscope slide under a cover slip and examined.

A necropsy was performed on all animals. The brain, heart, right kidney, liver, lung, right testis, and thymus were weighed. Tissues for microscopic examination were fixed and preserved in 10% neutral buffered formalin, processed and trimmed, embedded in paraffin, sectioned to a thickness of 6 μ m, and stained with hematoxylin and eosin. A complete histopathologic examination was performed on chamber control and 4,000 ppm male rats, chamber control and 2,000 ppm female rats, and chamber control and 2,000 ppm mice. Table 1 lists the tissues and organs routinely examined.

2-YEAR STUDIES

Study Design

Groups of 50 male and 50 female rats and mice were exposed to isobutyraldehyde at concentrations of 0, 500, 1,000, or 2,000 ppm for 6 hours plus T_{90} (12 minutes) per day, 5 days per week for 105 weeks. Following the last day of exposure, animals were observed for 3 to 7 days prior to necropsy. These concentrations gave estimated doses of 0.4, 0.8, or 1.6 mg isobutyraldehyde per kilogram body weight per day for rats and 0.5, 1.0, or 2 mg/kg per day for mice. The estimate for the rats was based on a 6-hour exposure period per day, a respiratory volume of 260 mL per minute, and mean body weights of 350 g for males and 270 g for females. The calculation for mice was based on a 6-hour exposure period per day,

a respiratory volume of 44 mL per minute, and mean body weight of 42 g for males and females (Bond, 1988).

Source and Specification of Animals

Male and female F344/N rats and B6C3F₁ mice were obtained from Simonsen Laboratories (Gilroy, CA) for use in the 2-year studies. Rats and mice were quarantined for 14 days before the beginning of the studies. Five male and five female rats and mice were randomly selected for parasite evaluation and gross observation of disease. Rats and mice were approximately 6 weeks old at the beginning of the studies. The health of the animals was monitored during the studies according to the protocols of the NTP Sentinel Animal Program (Appendix K).

Animal Maintenance

Rats and mice were housed individually. Water was available *ad libitum*; feed was available *ad libitum* except during exposure periods. Chambers, cages, and racks were rotated weekly. Further details of animal maintenance are given in Table 1. Information on feed composition and contaminants is provided in Appendix J.

Clinical Examinations and Pathology

All animals were observed twice daily. Body weights were recorded initially, weekly for 12 weeks (rats) or 13 weeks (mice), monthly thereafter until week 91 (rats) or week 92 (mice), every 2 weeks until study termination, and at the end of the studies. Clinical findings were recorded at 4-week intervals until week 91 (rats) or week 92 (mice), then every 2 weeks until the end of the studies.

A complete necropsy and microscopic examination were performed on all rats and mice. At necropsy, all organs and tissues were examined for grossly visible lesions, and all major tissues were fixed and preserved in 10% neutral buffered formalin, processed and trimmed, embedded in paraffin, sectioned to a thickness of 5 to 6 μm , and stained with hematoxylin and eosin for microscopic examination. For all paired organs (e.g., adrenal gland, kidney, ovary), samples from each organ were examined. Tissues examined microscopically are listed in Table 1.

Microscopic evaluations were completed by the study laboratory pathologist, and the pathology data were entered into the Toxicology Data Management System. The slides, paraffin blocks, and residual wet tissues were sent to the NTP Archives for inventory, slide/block match, and wet tissue audit. The slides, individual animal data records, and pathology tables were evaluated by an independent quality assessment laboratory. The individual animal records and tables were compared for accuracy, the slide and tissue counts were verified, and the histotechnique was evaluated. For the 2-year studies, a quality assessment pathologist evaluated slides from all tumors and all potential target organs, which included the adrenal gland (female rats), heart (male mice), larynx, liver (rats and male mice), lung, mammary gland (female rats), nose, pituitary gland (rats), skin (males), spleen (rats), forestomach (male rats), thyroid gland (female mice), trachea, and testis (male rats).

The quality assessment report and the reviewed slides were submitted to the NTP Pathology Working Group (PWG) chairperson, who reviewed the selected tissues and addressed any inconsistencies in the diagnoses made by the laboratory and quality assessment pathologists. Representative histopathology slides containing examples of lesions related to chemical administration, examples of disagreements in diagnoses between the laboratory and quality assessment pathologists, or lesions of general interest were presented by the chairperson to the PWG for review. The PWG consisted of the quality assessment pathologist and other pathologists experienced in rodent toxicologic pathology. This group examined the tissues without any knowledge of dose groups or previously rendered diagnoses. When the PWG consensus differed from the opinion of the laboratory pathologist, the diagnosis was changed. Final diagnoses for reviewed lesions represent a consensus between the laboratory pathologist, reviewing pathologist(s), and the PWG. Details of these review procedures have been described, in part, by Maronpot and Boorman (1982) and Boorman *et al.* (1985). For subsequent analyses of the pathology data, the decision of whether to evaluate the diagnosed lesions for each tissue type separately or combined was generally based on the guidelines of McConnell *et al.* (1986).

TABLE 1
Experimental Design and Materials and Methods in the Inhalation Studies of Isobutyraldehyde

13-Week Studies	2-Year Studies
Study Laboratory Litton Bionetics, Inc. (Kensington, MD)	Battelle Pacific Northwest Laboratories (Richland, WA)
Strain and Species Rats: F344/N Mice: B6C3F ₁	Rats: F344/N Mice: B6C3F ₁
Animal Source Frederick Cancer Research Facility (Frederick, MD)	Simonsen Laboratories (Gilroy, CA)
Time Held Before Studies 13 days 14 days	
Average Age When Studies Began 6 weeks	6 weeks
Date of First Exposure Rats: 24 May 1983 Mice: 23 May 1983	Rats: 16 August 1990 Mice: 9 August 1990
Duration of Exposure 6 hours plus T ₉₀ (12 minutes) per day, 5 days per week, for 13 weeks	6 hours plus T ₉₀ (12 minutes) per day, 5 days per week, for 105 weeks
Date of Last Exposure Rats: 24–25 August 1983 Mice: 23–24 August 1983	Rats: 14 August 1992 Mice: 7 August 1992
Necropsy Dates Rats: 25–26 August 1983 Mice: 24–25 August 1983	Rats: 17–19 August 1992 Mice: 10–14 August 1992
Average Age at Necropsy 19 weeks	111 weeks
Size of Study Groups 10 males and 10 females	50 males and 50 females
Method of Distribution Animals were distributed randomly into groups of approximately equal initial mean body weights.	Same as 13-week studies
Animals per Cage 1	1
Method of Animal Identification Toe clip	Tail tattoo
Diet NIH-07 Open Formula pellet diet (Zeigler Brothers, Inc., Gardners, PA); available <i>ad libitum</i> , except during exposure periods changed daily	Same as 13-week studies, changed weekly
Water Tap water (Rockville municipal supply) via automatic watering system (Edstrom Industries, Waterford, WI); available <i>ad libitum</i>	Tap water (Richland municipal supply) via automatic watering system (Edstrom Industries, Waterford, WI); available <i>ad libitum</i>

TABLE 1
Experimental Design and Materials and Methods in the Inhalation Studies of Isobutyraldehyde (continued)

13-Week Studies	2-Year Studies
Cages Stainless steel (Allentown Caging, Allentown, NJ); changed twice weekly	Stainless steel (Hazleton Systems, Inc., Aberdeen, MD); changed weekly
Bedding DACB® Neomycin™ Treated Desorb Cageboard (Shepherd Specialty Papers, Inc., Kalamazoo, MI)	Techsorb® cageboard (Shepherd Specialty Papers, Inc., Kalamazoo, MI); changed daily
Chamber Air Supply Filters HEPA and charcoal filters	Single HEPA (Flanders Filters, Inc., San Rafael, CA) and charcoal (RSE, Inc., New Baltimore, MI)
Chambers Rochester design	Stainless steel (Lab Products, Inc., Aberdeen, MD); changed weekly
Animal Room Environment Temperature: 20.4°–21.8° C Relative humidity: 43%–66% Room fluorescent light: 12 hours/day Room air changes: 12–15/hour	Temperature: 23.8°–24.2° C Relative humidity: 52%–58% Room fluorescent light: 12 hours/day Room air changes: 15/hour
Exposure Concentrations 0, 500, 1,000, 2,000, 4,000, or 8,000 ppm	0, 500, 1,000, or 2,000 ppm
Type and Frequency of Observation Observed twice daily and clinical findings were recorded weekly; animals were weighed initially, weekly, and at the end of the studies.	Observed twice daily; clinical findings were recorded at 4-week intervals until week 91 (rats) or week 92 (mice), and every two weeks thereafter; animals were weighed initially, weekly for 12 weeks (rats) or 13 weeks (mice), monthly thereafter until week 91 (rats) or week 92 (mice), every 2 weeks until study termination, and at the end of the studies.
Method of Sacrifice Anesthetization with carbon dioxide	Same as 13-week studies
Necropsy Necropsy was performed on all animals. Organs weighed were brain, heart, right kidney, liver, lung, right testis, and thymus.	Necropsy was performed on all animals.
Clinical Pathology Blood was collected by cardiac puncture from all rats and mice surviving to the end of the studies for hematology and from rats for clinical chemistry. Hematology: hematocrit, hemoglobin concentration, erythrocyte and reticulocyte counts, and total leukocyte counts and differentials Clinical chemistry: urea nitrogen, alanine aminotransferase, aspartate aminotransferase, and sorbitol dehydrogenase	None

TABLE 1
Experimental Design and Materials and Methods in the Inhalation Studies of Isobutyraldehyde (continued)

13-Week Studies	2-Year Studies
<p>Histopathology Complete histopathology was performed on 0 and 4,000 ppm male rats, 0 and 2,000 ppm female rats, 0 and 2,000 ppm mice, and all intercurrent deaths. In addition to gross lesions and tissue masses, the following tissues were examined: adrenal gland, bone with marrow, brain, clitoral gland (rats), esophagus, gallbladder (mice), heart, large intestine (cecum, colon, and rectum), small intestine (duodenum, jejunum, and ileum), kidney, liver, lung (and mainstem bronchi), lymph nodes (mandibular and mesenteric), mammary gland, nose, ovary, pancreas, parathyroid gland, pituitary gland, preputial gland (rats), prostate gland, salivary gland, skin, spleen, stomach (forestomach and glandular), testis (with epididymis and seminal vesicle), thymus, thyroid gland, trachea, urinary bladder, and uterus. In rats, the epididymis, larynx, nose, spleen, testes, thymus, and trachea were defined as the target organs and were examined in all remaining animals in the 500, 1,000, 2,000, and 4,000 ppm groups. In mice, the nose, spleen, and thymus were defined as the target organs and were examined for all remaining animals in the 500 and 1,000 ppm groups.</p>	<p>Complete histopathology was performed on all rats and mice. In addition to gross lesions and tissue masses, the following tissues were examined: adrenal gland, bone with marrow, brain, clitoral gland, esophagus, gallbladder (mice), heart, large intestine (cecum, colon, and rectum), small intestine (duodenum, jejunum, and ileum), kidney, larynx, liver, lung (and mainstem bronchi), lymph nodes (mandibular and mesenteric), mammary gland, nose, ovary, pancreas, parathyroid gland, pituitary gland, preputial gland, prostate gland, salivary gland, skin, spleen, stomach (forestomach and glandular), testis (with epididymis and seminal vesicle), thymus, thyroid gland, trachea, urinary bladder, and uterus.</p>
<p>Sperm Motility and Vaginal Cytology At the end of the studies, sperm samples were collected from all male rats and mice in the 0, 500, 1,000, 2,000, and 4,000 ppm exposure groups for sperm motility and morphology evaluations. The following parameters were evaluated: sperm concentration, motility, and percent abnormality. The right cauda, right epididymis, and right testis were weighed. Vaginal samples were collected for up to 12 consecutive days prior to the end of the studies from all females exposed to 0, 500, 1,000, 2,000, or 4,000 (rats only) ppm for vaginal cytology evaluations. The following parameters were evaluated: the relative frequency of estrous stages and estrous cycle length.</p>	<p>None</p>

STATISTICAL METHODS

Survival Analyses

The probability of survival was estimated by the product-limit procedure of Kaplan and Meier (1958) and is presented in the form of graphs. Animals found dead of other than natural causes or missing were censored from the survival analyses; animals dying from natural causes were not censored. Statistical analyses for possible dose-related effects on survival used Cox's (1972) method for testing two groups for equality and Tarone's (1975) life table test to identify dose-related trends. All reported P values for the survival analyses are two sided.

Calculation of Incidence

The incidences of neoplasms or nonneoplastic lesions are presented in Tables A1, A5, B1, B5, C1, C5, D1,

and D5 as the numbers of animals bearing such lesions at a specific anatomic site and the numbers of animals with that site examined microscopically. For calculation of statistical significance, the incidences of most neoplasms (Tables A3, B3, C3, and D3) and all nonneoplastic lesions are given as the numbers of animals affected at each site examined microscopically. However, when macroscopic examination was required to detect neoplasms in certain tissues (e.g., hardyrian gland, intestine, mammary gland, and skin) before microscopic evaluation, or when neoplasms had multiple potential sites of occurrence (e.g., leukemia or lymphoma), the denominators consist of the number of animals on which a necropsy was performed. Tables A3, B3, C3, and D3 also give the survival-adjusted neoplasm rate for each group and each site-specific neoplasm, i.e., the Kaplan-Meier estimate of the neoplasm incidence that would

have been observed at the end of the study in the absence of mortality from all other competing risks (Kaplan and Meier, 1958).

Analysis of Neoplasm Incidences

The majority of neoplasms in these studies were considered to be incidental to the cause of death or not rapidly lethal. Thus, the primary statistical method used was logistic regression analysis, which assumed that the diagnosed neoplasms were discovered as the result of death from an unrelated cause and thus did not affect the risk of death. In this approach, neoplasm prevalence was modeled as a logistic function of chemical exposure and time. Both linear and quadratic terms in time were incorporated initially, and the quadratic term was eliminated if the fit of the model was not significantly enhanced. The neoplasm incidences of exposed and control groups were compared on the basis of the likelihood score test for the regression coefficient of dose. This method of adjusting for intercurrent mortality is the prevalence analysis of Dinse and Lagakos (1983), further described and illustrated by Dinse and Haseman (1986). When neoplasms are incidental, this comparison of the time-specific neoplasm prevalences also provides a comparison of the time-specific neoplasm incidences (McKnight and Crowley, 1984).

In addition to logistic regression, other methods of statistical analysis were used, and the results of these tests are summarized in the appendixes. These methods include the life table test (Cox, 1972; Tarone, 1975), appropriate for rapidly lethal neoplasms, and the Fisher exact test and the Cochran-Armitage trend test (Armitage, 1971; Gart *et al.*, 1979), procedures based on the overall proportion of neoplasm-bearing animals.

Tests of significance included pairwise comparisons of each exposed group with controls and a test for an overall dose-related trend. Continuity-corrected tests were used in the analysis of neoplasm incidence, and reported P values are one sided. The procedures described in the preceding paragraphs were also used to evaluate selected nonneoplastic lesions. For further discussion of these statistical methods, refer to Haseman (1984).

Analysis of Nonneoplastic Lesion Incidences

Because all nonneoplastic lesions in this study were considered to be incidental to the cause of death or not rapidly lethal, the primary statistical analysis used was a logistic regression analysis in which nonneoplastic lesion prevalence was modeled as a logistic function of chemical exposure and time.

Analysis of Continuous Variables

Two approaches were employed to assess the significance of pairwise comparisons between exposed and control groups in the analysis of continuous variables. Organ and body weight data, which have approximately normal distributions, were analyzed with the parametric multiple comparison procedures of Dunnett (1955) and Williams (1971, 1972). Hematology, clinical chemistry, and epididymal spermatozoal data, which have typically skewed distributions, were analyzed using the nonparametric multiple comparison methods of Shirley (1977) and Dunn (1964). Jonckheere's test (Jonckheere, 1954) was used to assess the significance of the dose-related trends and to determine whether a trend-sensitive test (Williams' or Shirley's test) was more appropriate for pairwise comparisons than a test that does not assume a monotonic dose-related trend (Dunnett's or Dunn's test). Prior to statistical analysis, extreme values identified by the outlier test of Dixon and Massey (1951) were examined by NTP personnel, and implausible values were eliminated from the analysis. Average severity values were analyzed for significance with the Mann-Whitney U test (Hollander and Wolfe, 1973). Because vaginal cytology data are proportions (the proportion of the observation period that an animal was in a given estrous stage), an arcsine transformation was used to bring the data into closer conformance with a normality assumption. Treatment effects were investigated by applying a multivariate analysis of variance (Morrison, 1976) to the transformed data to test for simultaneous equality of measurements across exposure concentrations.

Historical Control Data

Although the concurrent control group is always the first and most appropriate control group used for evaluation, historical control data can be helpful in the overall assessment of neoplasm incidence in certain

instances. Consequently, neoplasm incidences from the NTP historical control database, which is updated yearly, are included in the NTP reports for neoplasms appearing to show compound-related effects.

QUALITY ASSURANCE METHODS

The 13-week and 2-year studies were conducted in compliance with Food and Drug Administration Good Laboratory Practice Regulations (21 CFR, Part 58). In addition, as records from the 2-year studies were submitted to the NTP Archives, these studies were audited retrospectively by an independent quality assurance contractor. Separate audits covered completeness and accuracy of the pathology data, pathology specimens, final pathology tables, and a draft of this NTP Technical Report. Audit procedures and findings are presented in the reports and are on file at NIEHS. The audit findings were reviewed and assessed by NTP staff, and all comments were resolved or otherwise addressed during the preparation of this Technical Report.

GENETIC TOXICOLOGY

The genetic toxicity of isobutyraldehyde was assessed by testing the ability of the chemical to induce mutations in various strains of *Salmonella typhimurium*, mutations in L5178Y mouse lymphoma cells, sister chromatid exchanges and chromosomal aberrations in cultured Chinese hamster ovary cells, sex-linked recessive lethal mutations in *Drosophila melanogaster*, chromosomal aberrations in mouse bone marrow cells, and induction of micronucleated erythrocytes in bone marrow cells of mice and rats. The protocols for these studies and the results are given in Appendix E.

The genetic toxicity studies of isobutyraldehyde are part of a larger effort by the NTP to develop a database that would permit the evaluation of carcinogenicity in experimental animals from the molecular structure and the effects of the chemical in short-term

in vitro and *in vivo* genetic toxicity tests. These genetic toxicity tests were originally developed to study mechanisms of chemically induced DNA damage and to predict carcinogenicity in animals, based on the electrophilicity theory of chemical mutagenesis and the somatic mutation theory of cancer (Miller and Miller, 1977; Straus, 1981; Crawford, 1985).

There is a strong correlation between a chemical's potential electrophilicity (structural alert to DNA reactivity), mutagenicity in *Salmonella*, and carcinogenicity in rodents. The combination of electrophilicity and *Salmonella* mutagenicity is highly correlated with the induction of carcinogenicity in rats and mice and/or at multiple tissue sites (Ashby and Tennant, 1991). Other *in vitro* genetic toxicity tests correlate less well with rodent carcinogenicity (Tennant *et al.*, 1987; Zeiger *et al.*, 1990), although these other tests can provide information on the types of DNA and chromosome effects that can be induced by the chemical being investigated. Data from NTP studies show that a positive response in *Salmonella* is the most predictive *in vitro* test for rodent carcinogenicity (89% of the *Salmonella* mutagens are rodent carcinogens), and that there is no complementarity among the *in vitro* genetic toxicity tests. That is, no battery of tests that included the *Salmonella* test improved the predictivity of the *Salmonella* test alone.

The predictivity for carcinogenicity of a positive response in bone marrow chromosome aberration or micronucleus tests appears to be less than the *Salmonella* test (Shelby *et al.*, 1993; Shelby and Witt, 1995). Positive responses in long-term peripheral blood micronucleus tests have not been formally evaluated for their predictivity for rodent carcinogenicity. But, because of the theoretical and observed associations between induced genetic damage and adverse effects in somatic and germ cells, the determination of *in vivo* genetic effects is important to the overall understanding of the risks associated with exposure to a particular chemical.

RESULTS

RATS

13-WEEK STUDY

The exposure concentrations (0, 500, 1,000, 2,000, 4,000, or 8,000 ppm) used were the same as those used in a flawed 14-day study. The design of the 14-day study was flawed because of poor randomization of animals and a faulty vapor generation system.

All rats exposed to 8,000 ppm died before the end of the study (Table 2). Three male rats and six female

rats in the 4,000 ppm groups and one female in the 500 ppm group died before the end of the study. The final mean body weight of 4,000 ppm males and the body weight gains of 4,000 ppm males and females were significantly less than those of the chamber controls. Clinical findings in rats exposed to 4,000 or 8,000 ppm included abnormal respiratory sounds, decreased activity, nasal discharge, prostration, and slowed respiration.

TABLE 2
Survival and Body Weights of Rats in the 13-Week Inhalation Study of Isobutylaldehyde

Concentration (ppm)	Survival ^a	Mean Body Weight ^b (g)			Final Weight Relative to Controls (%)
		Initial	Final	Change	
Male					
0	10/10	128 ± 2	343 ± 7	215 ± 7	
500	10/10	126 ± 3	353 ± 5	227 ± 5	103
1,000	10/10	124 ± 2	348 ± 6	224 ± 6	101
2,000	10/10	126 ± 2	358 ± 5	232 ± 4	104
4,000	7/10 ^c	127 ± 2	304 ± 4**	178 ± 4**	89
8,000	0/10 ^d	126 ± 3	—	—	—
Female					
0	10/10	98 ± 2	193 ± 3	95 ± 3	
500	9/10 ^e	99 ± 1	199 ± 2	101 ± 1	103
1,000	10/10	98 ± 2	199 ± 3	100 ± 2	103
2,000	10/10	99 ± 2	203 ± 6	103 ± 5	105
4,000	4/10 ^c	101 ± 1	180 ± 8	79 ± 7*	93
8,000	0/10 ^d	97 ± 1	—	—	—

* Significantly different ($P \leq 0.05$) from the chamber control group by Williams' or Dunnett's test

** $P \leq 0.01$

^a Number of animals surviving at 13 weeks/number initially in group

^b Weights and weight changes are given as mean ± standard error. Subsequent calculations are based on animals surviving to the end of the study. No data were calculated for groups with 100% mortality.

^c Week of death: 7

^d Week of death: 1

^e Week of death: 12

The relative kidney weight of 4,000 ppm males was significantly greater than that of the chamber controls (Table F1). Absolute liver and thymus weights of male rats in the 4,000 ppm group were significantly less than those of the chamber controls. The absolute brain weight of female rats in the 4,000 ppm group was significantly less than that of the chamber controls. These absolute organ weight differences are likely secondary to body weight differences.

The hematology and clinical chemistry data for rats in the 13-week inhalation study of isobutyraldehyde are listed in Table G1. A minimal mature neutrophilia, evidenced by increased segmented neutrophil numbers, occurred in exposed groups of male and female rats; these findings would be consistent with upper respiratory tract inflammation observed in the exposed rats. Minimal increases in alanine aminotransferase activity occurred in an exposure-related manner in male and female rats. Sorbitol dehydrogenase activity, another marker of increased hepatocellular permeability/leakage, did not increase; this suggests that the increase in alanine aminotransferase activity may be related to enzyme induction instead of cell membrane injury. Other differences in hematology and clinical chemistry parameters were not considered toxicologically relevant.

The caudae and epididymis weights of 4,000 ppm male rats were significantly less than those of the chamber controls (Table H1); these decreases are likely secondary to lower mean body weights. Spermatozoal motility in 500 and 1,000 ppm males was significantly reduced as compared to the chamber controls. Females exposed to 4,000 ppm differed significantly from the chamber control females in the relative time spent in the estrous stages. Generally, exposed females spent more time in diestrus and less time in proestrus than the chamber control females (Table H1).

Gross lesions that could be attributed to isobutyraldehyde exposure were not evident at necropsy. Male and female rats exposed to 8,000 ppm had congestion and severe necrosis of the epithelium, and occasionally of the entire mucosa, of the nasal turbinates accompanied by acute inflammation (Plate 1), and accumulation of serous or fibropurulent exudate

within the nasal passages (Table 3). Male and female rats exposed to 4,000 ppm had mild epithelial hyperplasia of the mucosa of the nasal cavity and nasopharynx. Increased incidences of squamous metaplasia and mild acute (suppurative) inflammation occurred in male and female rats exposed to 4,000 ppm (Plates 2 and 3). In addition, male rats exposed to 4,000 or 8,000 ppm and females exposed to 4,000 ppm had mild osteodystrophy in the bones of the maxillo- and nasoturbinates characterized by decreased numbers of osteoblasts, increased numbers of osteoclasts, decreased bone density, and increased amounts of periosteal connective tissue. These changes were accompanied by inflammation of the overlying mucosa. Minimal to mild degeneration of the olfactory epithelium characterized by reduced thickness and loss of sensory cell nuclei was observed in all male rats exposed to 2,000 or 4,000 ppm and in three female rats exposed to 2,000 ppm.

In the larynx and trachea, the incidences of necrosis/degeneration were increased in male rats exposed to 8,000 ppm (Table 3).

Mild to moderate lymphoid depletion of the spleen and thymus was seen only in male and female rats exposed to 8,000 ppm and may have been a direct toxic effect and/or due to stress associated with isobutyraldehyde administration. The incidences of mild to moderate lymphoid necrosis of the thymus were significantly increased in 8,000 ppm male (10/10) and female (8/10) rats only. Minimal to mild maturation arrest in the testis characterized histologically as decreased numbers of germinal cells, reduced spermatogenesis, and/or increased numbers of large mononuclear cells (immature spermatogonia) in the ducts of the epididymis occurred in 8,000 ppm males (9/10). All 8,000 ppm males died during the first week of exposure.

Exposure Concentration Selection Rationale: Based on mortality, lower body weight gains, and the increased incidences and severities of nasal lesions observed in the 4,000 and 8,000 ppm groups, the isobutyraldehyde exposure concentrations selected for the 2-year inhalation study in rats were 500, 1,000, and 2,000 ppm.

TABLE 3
Incidences of Selected Nonneoplastic Lesions of the Respiratory Tract of Rats
in the 13-Week Inhalation Study of Isobutylaldehyde

	Chamber Control	500 ppm	1,000 ppm	2,000 ppm	4,000 ppm	8,000 ppm
Male						
Larynx ^a	10	10	10	10	10	10
Inflammation ^b	2 (1.0) ^c	1 (2.0)	1 (2.0)	1 (2.0)	2 (2.0)	2 (1.5)
Metaplasia, Squamous	0	0	0	0	0	1
Necrosis/Degeneration	0	0	0	0	0	5*
Nose	10	10	10	10	10	10
Acute Necrosis	0	0	0	0	0	10** (3.8)
Congestion	0	0	0	0	0	10**
Epithelium, Hyperplasia	0	0	0	0	10** (2.3)	0
Exudate, Fibropurulent	0	0	0	0	0	10**
Exudate, Serous	0	0	0	0	0	6**
Exudate, Suppurative	0	0	0	0	9** (1.9)	0
Goblet Cell Hyperplasia	0	0	0	3	0	0
Inflammation, Suppurative	1 (2.0)	3 (1.0)	0	1 (2.0)	10** (2.4)	0
Metaplasia, Squamous	0	0	0	0	9** (2.0)	0
Olfactory Epithelium, Degeneration	0	0	0	10**	10**	0
Subepithelial Mineralization	0	0	0	0	1	1
Turbinates Bone, Osteodystrophy	0	0	0	0	2	5*
Trachea	9	10	— ^d	—	10	10
Inflammation	1 (2.0)	2 (1.5)			2 (1.5)	1 (2.0)
Metaplasia, Squamous	0	0			0	2
Necrosis/Degeneration	0	0			0	6**
Female						
Larynx	10	10	—	10	10	10
Inflammation	0	1 (2.0)		3 (2.0)	3 (1.7)	3 (1.7)
Necrosis, Epithelium, Degeneration	0	0		0	0	3
Nose	10	10	10	10	10	10
Acute Necrosis	0	0	0	0	0	10** (3.6)
Congestion	0	0	0	0	0	10**
Epithelium, Hyperplasia	0	0	0	0	6** (2.5)	0
Exudate, Fibropurulent	0	0	0	0	0	10**
Exudate, Serous	0	0	0	0	3	7**
Exudate, Suppurative	0	0	0	0	3 (2.0)	0
Goblet Cell Hyperplasia	0	0	3 (1.0)	0	0	0
Inflammation, Suppurative	2 (1.5)	6 (1.0)	2 (1.0)	0	9** (1.7)	0
Metaplasia, Squamous	0	0	0	0	4* (1.5)	0
Olfactory Epithelium, Degeneration	0	0	0	3	0	0
Turbinates Bone, Osteodystrophy	0	0	0	0	6**	0
Trachea	10	10	10	10	10	9
Inflammation	1 (2.0)	1 (2.0)	2 (2.0)	1 (1.0)	0	1 (2.0)
Metaplasia, Squamous	0	0	0	0	0	6**
Necrotizing Inflammation	0	0	0	0	0	2 (2.0)

* Significantly different ($P \leq 0.05$) from the chamber control group by the Fisher exact test

** $P \leq 0.01$

^a Number of animals with tissue examined microscopically

^b Number of animals with lesion

^c Average severity grade of lesions in affected animals: 1= minimal, 2= mild, 3= moderate, 4= marked; some severities not available

^d Tissue not examined at this exposure concentration

2-YEAR STUDY

Survival

Estimates of 2-year survival probabilities for male and female rats are shown in Table 4 and in the Kaplan-Meier survival curves (Figure 1). There were no significant differences in survival rates between exposed and chamber control male or female rats.

Body Weights and Clinical Findings

Mean body weights are given in Tables 5 and 6 and Figure 2. The mean body weights of male and female rats were generally similar to those of the chamber controls throughout the study. No clinical findings that could be attributed to isobutyraldehyde exposure were observed.

TABLE 4
Survival of Rats in the 2-Year Inhalation Study of Isobutyraldehyde

	Chamber Control	500 ppm	1,000 ppm	2,000 ppm
Male				
Animals initially in study	50	50	50	50
Moribund	35	32	34	35
Natural deaths	3	3	5	5
Animals surviving to study termination	12	15	11	10
Percent probability of survival at end of study ^a	24	30	22	20
Mean survival (days) ^b	641	650	623	625
Survival analysis ^c	P= 0.171	P= 0.618N	P= 0.561	P= 0.323
Female				
Animals initially in study	50	50	50	50
Accidental death ^d	0	1	0	0
Moribund	17	22	22	13
Natural deaths	6	3	4	5
Animals surviving to study termination	27	24	24	32 ^e
Percent probability of survival at end of study	54	49	48	64
Mean survival (days)	659	672	693	689
Survival analysis	P= 0.265N	P= 0.954	P= 1.000	P= 0.367N

^a Kaplan-Meier determinations

^b Mean of all deaths (uncensored, censored, and terminal sacrifice)

^c The result of the life table trend test (Tarone, 1975) is in the chamber control column, and the results of the life table pairwise comparisons (Cox, 1972) with the chamber controls are in the exposed group columns. A negative trend or lower mortality in an exposure group is indicated by N.

^d Censored from survival analyses

^e Includes one animal that died during the last week of the study

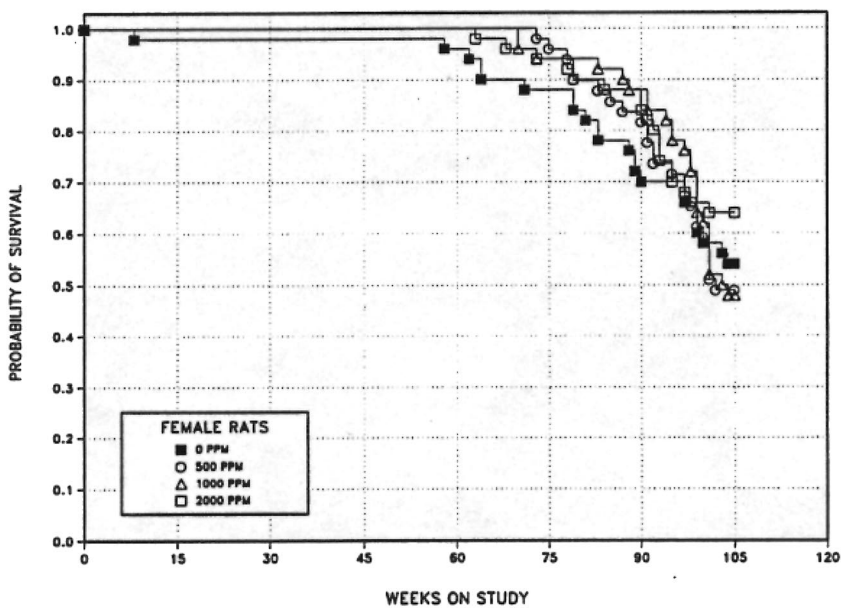
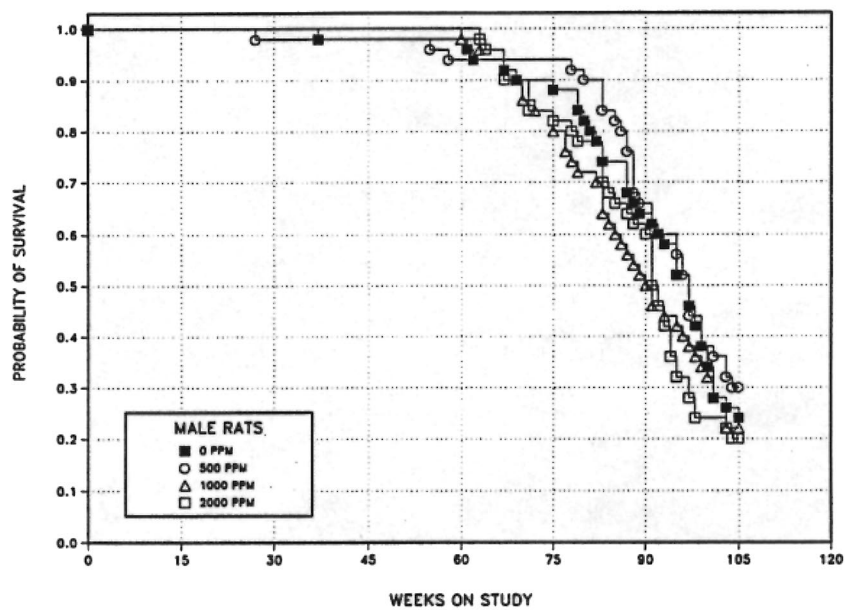

FIGURE 1
Kaplan-Meier Survival Curves for Male and Female Rats
Exposed to Isobutyraldehyde by Inhalation for 2 Years

TABLE 5
Mean Body Weights and Survival of Male Rats in the 2-Year Inhalation Study of Isobutyraldehyde

Weeks on Study	Chamber Control		500 ppm			1,000 ppm			2,000 ppm		
	Av. Wt. (g)	No. of Survivors	Av. Wt. (g)	Wt. (% of controls)	No. of Survivors	Av. Wt. (g)	Wt. (% of controls)	No. of Survivors	Av. Wt. (g)	Wt. (% of controls)	No. of Survivors
1	126	50	126	100	50	125	100	50	125	99	50
2	170	50	171	101	50	170	100	50	168	99	50
3	203	50	206	101	50	205	101	50	202	100	50
4	233	50	234	100	50	232	100	50	229	98	50
5	255	50	257	101	50	255	100	50	253	99	50
6	274	50	275	101	50	275	101	50	271	99	50
7	292	50	294	101	50	294	101	50	292	100	50
8	306	50	314	102	50	312	102	50	307	100	50
9	319	50	326	102	50	324	102	50	320	100	50
10	334	50	338	101	50	337	101	50	334	100	50
11	343	50	346	101	50	348	102	50	346	101	50
12	349	50	354	102	50	352	101	50	353	101	50
15	375	50	369	98	50	380	101	50	378	101	50
19	400	50	405	101	50	407	102	50	406	102	50
23	428	50	429	100	50	434	101	50	432	101	50
27	445	50	450	101	49	453	102	50	449	101	50
31	460	50	465	101	49	463	101	50	462	101	50
35	468	50	476	102	49	476	102	50	474	101	50
39	476	49	482	101	49	483	101	50	479	101	50
43	488	49	492	101	49	492	101	50	491	101	50
47	494	49	494	100	49	498	101	50	496	101	50
51	500	49	502	100	49	501	100	50	499	100	50
55	506	49	507	100	49	511	101	50	509	101	50
59	508	49	512	101	47	511	101	50	506	100	50
63	513	47	511	100	47	514	100	49	499	97	50
67	521	46	516	99	47	512	98	48	504	97	46
71	525	45	520	99	47	520	99	43	507	97	43
75	529	44	518	98	47	522	99	40	513	97	41
79	531	42	521	98	46	517	97	37	515	97	40
83	528	38	518	98	43	515	97	33	505	96	37
87	510	36	501	98	39	515	101	28	500	98	32
91	502	32	496	99	32	505	101	25	466	93	29
93	506	30	503	99	30	506	100	23	472	93	22
95	504	27	497	99	29	501	100	22	483	96	17
97	486	26	482	99	25	496	102	20	475	98	16
99	490	20	489	100	20	479	98	18	485	99	12
101	495	16	486	98	19	478	97	15	469	95	12
103	491	14	482	98	16	467	95	13	446	91	12
Mean for weeks											
1-13	267		270	101		269	101		267	100	
14-52	453		456	101		459	101		457	101	
53-103	509		504	99		504	99		491	96	

TABLE 6
Mean Body Weights and Survival of Female Rats in the 2-Year Inhalation Study of Isobutyraldehyde

Weeks on Study	Chamber Control		500 ppm			1,000 ppm			2,000 ppm		
	Av. Wt. (g)	No. of Survivors	Av. Wt. (g)	Wt. (% of controls)	No. of Survivors	Av. Wt. (g)	Wt. (% of controls)	No. of Survivors	Av. Wt. (g)	Wt. (% of controls)	No. of Survivors
1	102	50	102	100	50	101	99	50	101	99	50
2	124	50	124	100	50	123	99	50	122	99	50
3	138	50	138	100	50	137	99	50	138	99	50
4	150	50	149	99	50	148	99	50	148	99	50
5	159	50	158	100	50	158	100	50	158	100	50
6	165	50	166	100	50	165	100	50	166	101	50
7	172	50	172	100	50	172	100	50	173	100	50
8	180	50	180	100	50	179	100	50	180	100	50
9	183	49	183	100	50	184	100	50	185	101	50
10	188	49	188	100	50	187	100	50	189	101	50
11	193	49	193	100	49	192	100	50	194	100	50
12	195	49	196	101	49	191	98	50	196	101	50
15	204	49	202	99	49	204	100	50	207	101	50
19	213	49	214	100	49	212	100	50	215	101	50
23	226	49	227	100	49	223	99	50	226	100	50
27	233	49	236	101	49	233	100	50	236	101	50
31	242	49	244	101	49	238	99	50	240	99	50
35	251	49	253	101	49	247	99	50	249	99	50
39	258	49	261	101	49	255	99	50	261	101	50
43	270	49	272	101	49	267	99	50	270	100	50
47	282	49	279	99	49	276	98	50	281	100	50
51	294	49	295	100	49	288	98	50	291	99	50
55	305	49	305	100	49	300	98	50	301	99	50
59	309	48	310	100	49	307	99	50	307	99	50
63	316	47	318	101	49	317	100	50	313	99	50
67	325	45	324	100	49	323	99	50	320	98	49
71	334	44	328	98	49	326	98	48	323	97	48
75	343	44	338	99	48	336	98	47	333	97	47
79	344	42	336	98	45	344	100	47	340	99	45
83	348	41	342	98	43	349	100	47	338	97	45
87	349	39	339	97	42	352	101	46	340	98	44
91	350	35	331	95	40	338	97	44	331	95	41
93	359	35	341	95	36	345	96	42	345	96	37
95	360	35	343	95	35	343	95	41	345	96	37
97	357	35	338	95	35	341	96	38	345	97	34
99	360	31	346	96	31	347	96	34	351	98	33
101	357	29	347	97	26	348	97	29	349	98	33
103	353	29	352	100	24	350	99	26	346	98	32
Mean for weeks											
1-13	162		162	100		161	99		163	101	
14-52	247		248	100		244	99		248	100	
53-103	342		334	98		335	98		333	97	

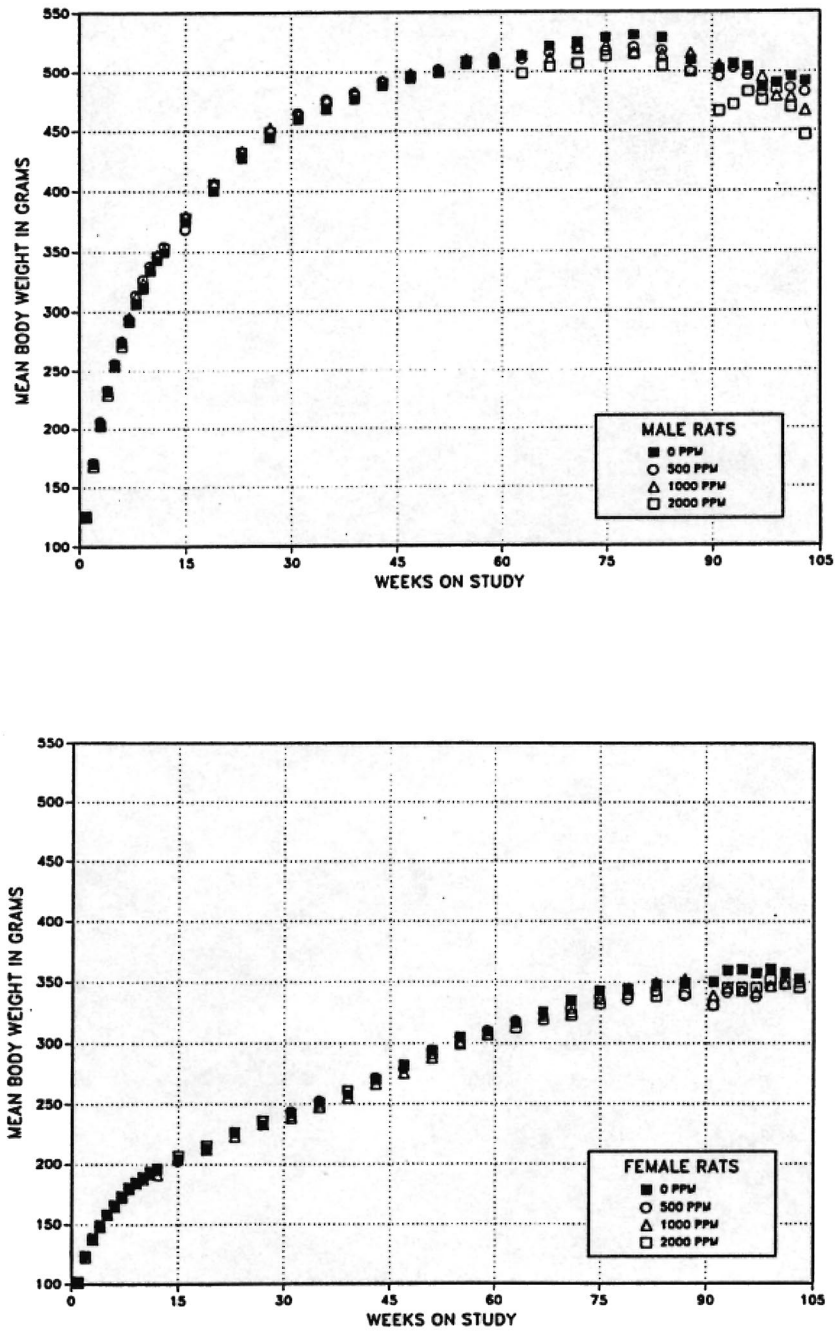

FIGURE 2
Growth Curves for Male and Female Rats
Exposed to Isobutyraldehyde by Inhalation for 2 Years

Pathology and Statistical Analyses

This section describes the statistically significant or biologically noteworthy changes in the incidences of mononuclear cell leukemia and of neoplasms and nonneoplastic lesions of the nose. Summaries of the incidences of neoplasms and nonneoplastic lesions, individual animal tumor diagnoses, statistical analyses of primary neoplasms that occurred with an incidence of at least 5% in at least one animal group, and historical incidences for the neoplasms mentioned in this section are presented in Appendix A for male rats and Appendix B for female rats.

Nose: Three primary nasal neoplasms were observed in male and female rats exposed to isobutyraldehyde (Tables 7, A1, and B1). One polypoid adenoma was present in the anterior nose section of a male rat exposed to 1,000 ppm, one adenoma of the vomeronasal organ was noted in a 2,000 ppm male, and an undifferentiated malignant neoplasm, classified as a sarcoma (mesenchymal origin), was present in the most posterior section of the nose in a 500 ppm female. Spontaneous nasal neoplasms occur very rarely in chamber control F344/N rats in the NTP historical database. In all 2-year NTP inhalation studies, one nasal adenoma occurred in 646 males (Table A4), and one nasal fibrosarcoma was observed in 645 females (Table B4a).

Exposure-related nonneoplastic lesions in the nose consisted of squamous metaplasia of the respiratory epithelium, degeneration of the olfactory epithelium, and suppurative inflammation (Tables 7, A5, and B5). The incidences of minimal to mild squamous meta-

plasia in 1,000 and 2,000 ppm males and females and in 500 ppm females were significantly greater than those in the chamber controls. This lesion occurred most frequently in the median septum, the medial aspect of the maxillary turbinates, and was characterized by replacement of the cuboidal and columnar ciliated epithelium and some keratinization in the surface cells. The incidences of minimal to mild degeneration of the olfactory epithelium in male and female rats exposed to 2,000 ppm were significantly greater than those in the chamber controls. Olfactory epithelial degeneration occurred in the dorsal wall in Level II of the nasal cavity. The affected olfactory epithelium had fewer layers of sensory cells, and the remaining cells were flattened and irregular (Plates 4 and 5). The incidences of suppurative inflammation (rhinitis) in male and female rats exposed to 2,000 ppm were increased compared to the chamber controls. This lesion was most notable in the anterior nasal section and occurred sometimes, but not always, in association with squamous metaplasia of the respiratory epithelium. The inflammation tended to be focal and was occasionally associated with foreign material.

Mononuclear Cell Leukemia: The incidence of mononuclear cell leukemia in 2,000 ppm female rats was significantly greater than in the chamber controls (chamber controls, 12/50; 500 ppm, 19/50; 1,000 ppm, 18/50; 2,000 ppm, 25/50; Table B3). However, the incidence in the chamber controls was low (24%), and the incidences in all exposed groups were within the historical control range from 2-year NTP inhalation studies (Table B4b).

TABLE 7
Incidences of Neoplastic and Nonneoplastic Lesions of the Nose of Rats in the 2-Year Inhalation Study of Isobutyraldehyde

	Chamber Control	500 ppm	1,000 ppm	2,000 ppm
Male				
Number Examined Microscopically	50	49	49	50
Inflammation, Suppurative ^a	5 (2.6) ^b	3 (2.7)	6 (2.0)	15** (2.1)
Olfactory Epithelium, Degeneration	0	0	3 (2.0)	44** (1.2)
Respiratory Epithelium, Squamous Metaplasia	1 (2.0)	1 (2.0)	10** (1.5)	44** (1.7)
Adenoma ^c	0	0	1	0
Vomeronasal Organ, Adenoma	0	0	0	1
Female				
Number Examined Microscopically	49	50	49	50
Inflammation, Suppurative	2 (1.5)	3 (2.0)	5 (2.8)	11* (1.7)
Olfactory Epithelium, Degeneration	0	0	2 (1.0)	45** (1.3)
Respiratory Epithelium, Squamous Metaplasia	1 (2.0)	11** (1.4)	9* (1.4)	44** (1.4)
Sarcoma ^d	0	1	0	0

* Significantly different ($P \leq 0.05$) from the chamber control by the logistic regression test

** $P \leq 0.01$

^a Number of animals with lesion

^b Average severity grade of lesions in affected animals: 1= minimal, 2= mild, 3= moderate, 4= marked

^c Historical incidence for 2-year NTP inhalation studies with chamber control groups (mean \pm standard deviation): 1/646 (0.2% \pm 0.6%); range, 0%-2%

^d Historical incidence of fibrosarcoma (no sarcomas have been observed): 1/645 (0.2% \pm 0.6%); range, 0%-2%

MICE

13-WEEK STUDY

The exposure concentrations (0, 500, 1,000, 2,000, 4,000, or 8,000 ppm) used were the same as those used in a flawed 14-day study. The design of the 14-day study was flawed because of poor randomization of animals and a faulty vapor generation system.

One male in the chamber control group, one male in the 1,000 ppm group, nine males in the 4,000 ppm group, and all males in the 8,000 ppm group died before the end of the study (Table 8). All female mice in the 4,000 and 8,000 ppm groups died before the end of the study. Final mean body weights and body weight gains of male mice were similar to those

of the chamber controls. The final mean body weight and body weight gain of female mice in the 1,000 ppm group were significantly less than those of the chamber controls. Clinical findings included decreased activity, tremors, prostration, and slower and labored respiration.

The absolute and relative kidney weights of males in the 1,000 and 2,000 ppm groups were significantly greater than those of the chamber controls (Table F2). The absolute liver weight of 1,000 ppm females and absolute and relative liver weights of 500 ppm females were significantly less than those of the chamber controls. The absolute thymus weight of 1,000 ppm females and the absolute and relative thymus weights of 2,000 ppm females were significantly less than those of the chamber controls.

TABLE 8
Survival and Body Weights of Mice in the 13-Week Inhalation Study of Isobutyraldehyde

Concentration (ppm)	Survival ^d	Mean Body Weight ^b (g)			Final Weight Relative to Controls (%)
		Initial	Final	Change	
Male					
0	9/10 ^c	21.0 ± 0.4	29.0 ± 0.6	8.0 ± 0.5	
500	10/10	21.4 ± 0.5	29.3 ± 0.5	7.9 ± 0.3	101
1,000	9/10 ^d	21.2 ± 1.0	29.4 ± 0.4	7.3 ± 0.7	101
2,000	10/10	18.8 ± 1.0	28.6 ± 0.4	9.8 ± 1.1	99
4,000	1/10 ^e	19.6 ± 0.4	19.9	0.6	69
8,000	0/10 ^f	19.5 ± 0.8	—	—	—
Female					
0	10/10	18.4 ± 0.3	27.0 ± 0.6	8.6 ± 0.4	
500	10/10	18.5 ± 0.4	26.3 ± 0.6	7.8 ± 0.4	97
1,000	10/10	18.1 ± 0.3	25.0 ± 0.3*	6.9 ± 0.2**	92
2,000	10/10	17.6 ± 0.5	25.5 ± 0.4	7.9 ± 0.5	94
4,000	0/10 ^g	18.6 ± 0.4	—	—	—
8,000	0/10 ^d	17.2 ± 0.5	—	—	—

* Significantly different ($P \leq 0.05$) from the chamber control group by Williams' or Dunnett's test

** $P \leq 0.01$

^a Number of animals surviving at 13 weeks/number initially in group

^b Weights and weight changes are given as mean ± standard error. Subsequent calculations are based on animals surviving to the end of the study. No statistical analyses were performed for groups with high mortality; no data were calculated for groups with 100% mortality.

^c Week of death: 12

^d Week of death: 1

^e Week of death: 6, 7, 9

^f Week of death: 1, 2

^g Week of death: 4, 6

No exposure-related hematology changes occurred in male or female mice (Table G2).

No differences in the epididymal spermatozoal parameters or estrous cycle lengths were observed in exposed mice (Table H2).

At necropsy no gross lesions that could be associated with isobutyraldehyde exposure were observed. Increased incidences of nonneoplastic lesions of the nasal cavity were observed in male and female mice exposed to 1,000 ppm or greater (Table 9); these lesions were histologically similar to those that occurred in rats. These lesions included necrosis, inflammation, hyperplasia, and squamous metaplasia of the epithelium; serous and suppurative exudate

within the nasal passages; olfactory epithelial degeneration; and osteodystrophy of the turbinate bone.

Mild to moderate lymphoid depletion occurred in the thymus of five male and five female mice exposed to 8,000 ppm. Mild to moderate lymphoid necrosis occurred in the thymus of three males and two females in the 8,000 ppm groups. Moderate lymphoid depletion was observed in the spleen of two male mice exposed to 8,000 ppm.

Exposure Concentration Selection Rationale: Based on mortality and increased incidences and severities of nasal lesions observed in the 4,000 and 8,000 ppm groups, exposure concentrations selected for the 2-year inhalation study in mice were 500, 1,000, and 2,000 ppm.

TABLE 9
Incidences of Nonneoplastic Lesions of the Nasal Cavity of Mice in the 13-Week Inhalation Study of Isobutyraldehyde

	Chamber Control	500 ppm	1,000 ppm	2,000 ppm	4,000 ppm	8,000 ppm
Male						
Number Examined Microscopically	10	10	10	10	10	10
Exudate, Suppurative ^a	0	0	0	0	9** (2.0) ^b	4* (5.0)
Exudate, Serous	0	2	0	4*	10**	3
Hyperplasia, Epithelial	0	0	0	0	2 (1.5)	0
Inflammation, Suppurative	0	0	5* (1.6)	0	0	0
Metaplasia, Squamous	0	0	0	0	5* (1.5)	2 (1.0)
Necrosis, Mucosal	0	0	0	0	3 (3.7)	7** (2.3)
Olfactory Epithelium, Degeneration	0	0	0	7**	0	0
Turbinate Bone, Osteodystrophy	0	0	0	0	5*	3
Female						
Number Examined Microscopically	10	10	10	10	10	10
Exudate, Suppurative	0	0	0	0	10** (1.3)	5* (1.4)
Exudate, Serous	0	0	0	3 (1.0)	10** (2.9)	3 (3.0)
Hyperplasia, Epithelial	0	0	4* (3.0)	1 (1.0)	0	0
Inflammation, Suppurative	0	3 (1.7)	6** (2.2)	0	0	0
Metaplasia, Squamous	0	0	0	0	9** (1.8)	0
Necrosis	0	1 (2.0)	0	0	3 (1.0)	6** (2.8)
Olfactory Epithelium, Degeneration	0	0	0	3	6**	0
Turbinate Bone, Osteodystrophy	0	0	0	0	9**	0

* Significantly different ($P \leq 0.05$) from the chamber control group by the Fisher exact test

** $P \leq 0.01$

^a Number of animals with lesion

^b Average severity grade of lesions in affected animals: 1= minimal, 2= mild, 3= moderate, 4= marked; some severities not available

2-YEAR STUDY

Survival

Estimates of 2-year survival probabilities for male and female mice are shown in Table 10 and in the Kaplan-Meier survival curves (Figure 3). Survival rates among male mice decreased with increasing exposure concentration. The survival rate of males exposed to 2,000 ppm was marginally reduced relative to the chamber controls. There were no significant differences in survival rates between exposed and chamber control females.

Body Weights and Clinical Findings

Mean body weights are given in Figure 4 and Tables 11 and 12. The mean body weights of male mice were generally similar to those of the chamber controls throughout the study. The mean body weights of female mice exposed to 1,000 or 2,000 ppm were less than those of the chamber controls during the second year of the study. No clinical findings that could be attributed to isobutyraldehyde exposure were observed.

TABLE 10
Survival of Mice in the 2-Year Inhalation Study of Isobutyraldehyde

	Chamber Control	500 ppm	1,000 ppm	2,000 ppm
Male				
Animals initially in study	50	50	50	50
Moribund	6	8	6	15
Natural deaths	4	5	9	5
Animals surviving to study termination	40	37	35	30
Percent probability of survival at end of study ^a	80	74	70	60
Mean survival (days) ^b	712	706	666	693
Survival analysis ^c	P= 0.034	P= 0.605	P= 0.270	P= 0.051
Female				
Animals initially in study	50	50	50	50
Accidental deaths ^d	1	1	0	0
Moribund	16	13	10	11
Natural deaths	5	4	4	2
Animals surviving to study termination	28	32	36 ^e	37
Percent probability of survival at end of study	57	65	72	74
Mean survival (days)	668	691	702	702
Survival analysis	P= 0.103N	P= 0.508N	P= 0.225N	P= 0.120N

^a Kaplan-Meier determinations

^b Mean of all deaths (uncensored, censored, and terminal sacrifice)

^c The result of the life table trend test (Tarone, 1975) is in the chamber control column, and the results of the life table pairwise comparisons (Cox, 1972) with the chamber controls are in the exposed group columns. A negative trend or lower mortality in an exposure group is indicated by N.

^d Censored from survival analyses

^e Includes one animal that died during the last week of the study

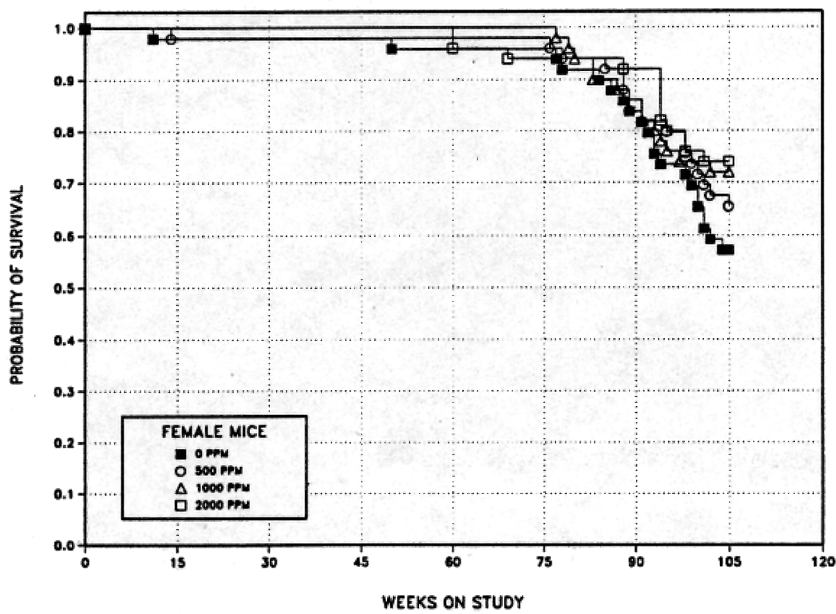
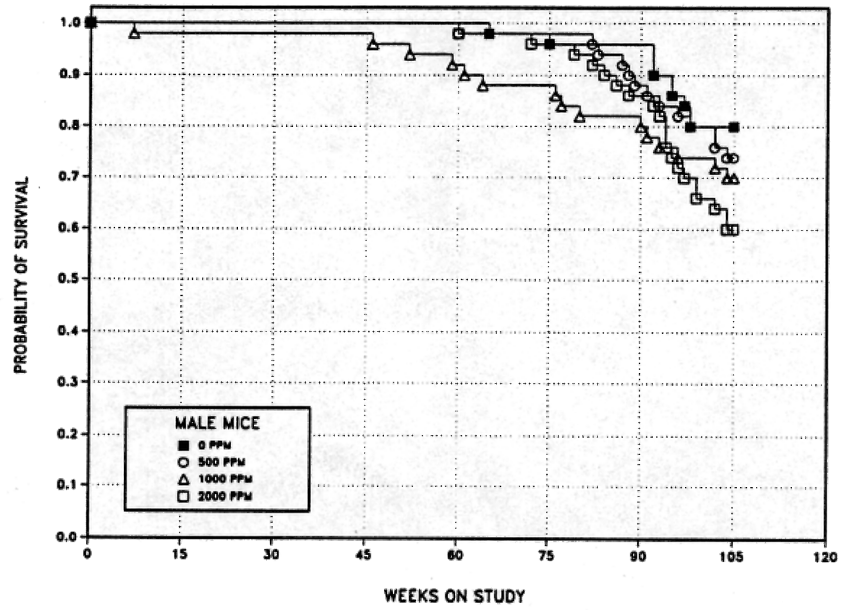

FIGURE 3
Kaplan-Meier Survival Curves for Male and Female Mice
Exposed to Isobutyraldehyde by Inhalation for 2 Years

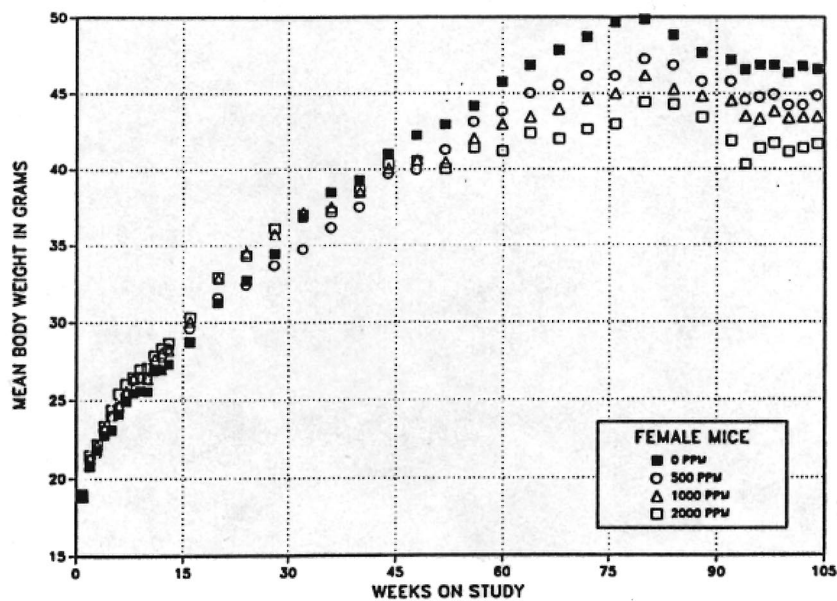
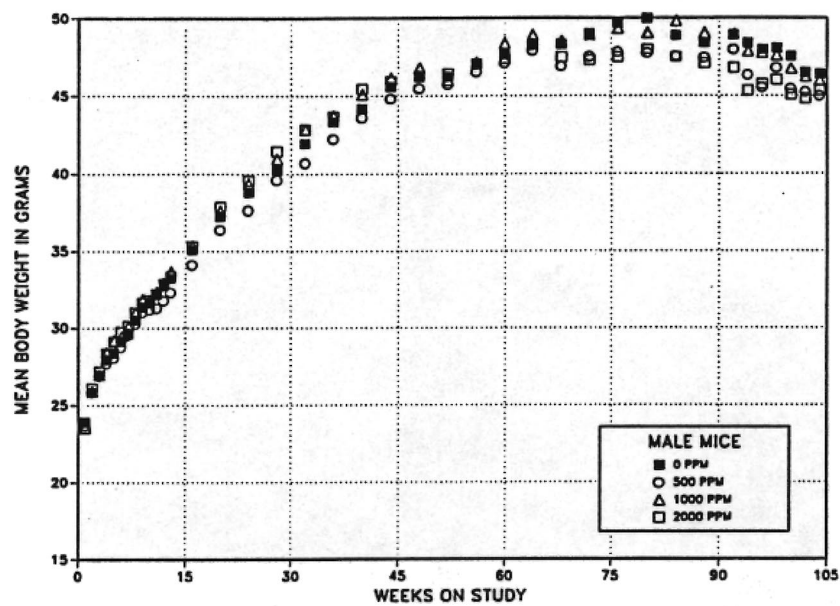

FIGURE 4
Growth Curves for Male and Female Mice
Exposed to Isobutyraldehyde by Inhalation for 2 Years

TABLE 11
Mean Body Weights and Survival of Male Mice in the 2-Year Inhalation Study of Isobutyraldehyde

Weeks on Study	Chamber Control		500 ppm			1,000 ppm			2,000 ppm		
	Av. Wt. (g)	No. of Survivors	Av. Wt. (g)	Wt. (% of controls)	No. of Survivors	Av. Wt. (g)	Wt. (% of controls)	No. of Survivors	Av. Wt. (g)	Wt. (% of controls)	No. of Survivors
1	23.9	50	23.7	99	50	23.6	99	50	23.5	98	50
2	25.8	50	25.8	100	50	25.9	100	50	26.1	101	50
3	26.9	50	26.9	100	50	27.0	100	50	27.2	101	50
4	28.0	50	27.7	99	50	28.4	101	50	28.3	101	50
5	28.4	50	28.1	99	50	29.2	103	50	29.1	103	50
6	29.1	50	28.8	99	50	29.4	101	50	29.7	102	50
7	29.6	50	29.5	100	50	30.1	102	49	30.2	102	50
8	30.5	50	30.3	99	50	31.0	102	49	31.0	102	50
9	31.4	50	31.0	99	50	31.9	102	49	31.7	101	50
10	31.6	50	31.2	99	50	31.8	101	49	31.8	101	50
11	32.2	50	31.3	97	50	32.3	100	49	32.2	100	50
12	32.7	50	31.8	97	50	33.0	101	49	32.9	101	50
13	33.2	50	32.3	97	50	33.7	102	49	33.4	101	50
16	35.1	50	34.1	97	50	35.3	101	49	35.3	101	50
20	37.3	50	36.4	98	50	37.6	101	49	37.9	102	50
24	38.8	50	37.6	97	50	39.4	102	49	39.6	102	50
28	40.2	50	39.6	99	50	41.0	102	49	41.4	103	50
32	41.9	50	40.7	97	50	42.9	102	49	42.8	102	50
36	43.3	50	42.2	98	50	43.7	101	49	43.7	101	50
40	44.1	50	43.6	99	50	45.1	102	49	45.5	103	50
44	45.6	50	44.8	98	50	46.2	101	49	46.0	101	50
48	46.2	50	45.5	99	50	46.8	101	48	46.3	100	50
52	46.2	50	45.8	99	50	46.0	100	48	46.5	101	50
56	47.0	50	46.6	99	50	47.2	100	47	47.1	100	50
60	47.7	50	47.1	99	50	48.4	102	46	47.4	99	50
64	48.4	50	48.0	99	49	49.0	101	45	48.3	100	49
68	48.4	49	46.9	97	49	48.6	100	44	47.5	98	49
72	49.0	49	47.6	97	49	48.9	100	44	47.3	97	49
76	49.7	48	47.9	96	49	49.4	99	44	47.5	96	48
80	50.0	48	47.8	96	49	49.1	98	42	48.0	96	47
84	48.9	48	47.6	97	47	49.9	102	41	47.6	97	46
88	48.4	48	47.5	98	45	49.1	101	41	47.1	97	44
92	48.9	48	48.0	98	43	49.0	100	39	46.8	96	43
94	48.4	45	46.4	96	42	47.9	99	38	45.4	94	41
96	48.0	43	45.5	95	42	47.8	100	38	45.8	95	37
98	48.1	42	46.8	97	40	47.7	99	37	46.0	96	36
100	47.6	40	45.5	96	40	46.8	98	37	45.1	95	33
102	46.5	40	45.3	97	40	46.3	100	37	44.8	96	33
104	46.4	40	45.0	97	38	46.0	99	36	45.4	98	31
Mean for weeks											
1-13	29.5		29.1	99		29.8	101		29.8	101	
14-52	41.9		41.0	98		42.4	101		42.5	101	
53-104	48.2		46.8	97		48.2	100		46.7	97	

TABLE 12
Mean Body Weights and Survival of Female Mice in the 2-Year Inhalation Study of Isobutyraldehyde

Weeks on Study	Chamber Control		500 ppm			1,000 ppm			2,000 ppm		
	Av. Wt. (g)	No. of Survivors	Av. Wt. (g)	Wt. (% of controls)	No. of Survivors	Av. Wt. (g)	Wt. (% of controls)	No. of Survivors	Av. Wt. (g)	Wt. (% of controls)	No. of Survivors
1	19.0	50	18.9	100	50	18.9	100	50	18.8	99	50
2	20.8	50	21.3	102	50	21.3	102	50	21.5	103	50
3	21.8	50	21.6	99	50	22.2	102	50	22.2	102	50
4	22.8	50	23.1	101	50	23.2	102	50	23.4	103	50
5	23.1	50	24.0	104	50	24.1	104	50	24.4	106	50
6	24.1	50	24.6	102	50	24.7	103	50	25.5	106	50
7	24.9	50	25.4	102	50	25.6	103	50	26.1	105	50
8	25.5	50	26.3	103	50	26.4	104	50	26.5	104	50
9	25.6	50	26.5	104	50	26.5	104	50	27.0	106	50
10	25.6	50	26.4	103	50	26.4	103	50	27.1	106	50
11	26.9	49	27.0	100	50	27.6	103	50	27.9	104	50
12	27.0	48	27.8	103	50	28.1	104	50	28.4	105	50
13	27.3	48	28.3	104	50	28.2	103	50	28.7	105	50
16	28.7	48	29.6	103	49	30.1	105	50	30.3	106	50
20	31.3	48	31.6	101	49	32.8	105	50	32.9	105	50
24	32.7	48	32.4	99	49	34.5	106	50	34.3	105	50
28	34.4	48	33.7	98	49	35.7	104	50	36.1	105	50
32	36.8	48	34.7	94	49	37.2	101	50	37.0	101	50
36	38.5	48	36.2	94	49	37.5	97	50	37.2	97	50
40	39.3	48	37.5	95	49	38.5	98	50	38.6	98	50
44	41.0	48	39.7	97	49	40.0	98	50	40.4	99	50
48	42.2	48	40.0	95	49	40.6	96	50	40.6	96	50
52	43.0	47	41.3	96	49	40.5	94	50	40.0	93	50
56	44.2	47	43.1	98	49	42.0	95	50	41.4	94	50
60	45.8	47	43.8	96	49	43.0	94	50	41.2	90	50
64	46.9	47	45.0	96	49	43.5	93	50	42.4	90	48
68	47.9	47	45.6	95	49	44.0	92	50	42.0	88	48
72	48.7	47	46.2	95	49	44.7	92	50	42.7	88	47
76	49.7	47	46.2	93	49	45.0	91	50	43.0	87	47
80	49.9	45	47.3	95	47	46.2	93	47	44.5	89	47
84	48.8	45	46.9	96	47	45.3	93	45	44.3	91	47
88	47.7	43	45.8	96	45	44.9	94	43	43.5	91	47
92	47.2	40	45.8	97	40	44.6	95	41	41.9	89	46
94	46.6	37	44.6	96	40	43.5	93	40	40.3	87	45
96	46.9	36	44.8	96	39	43.4	93	38	41.4	88	40
98	46.9	36	45.0	96	39	43.9	94	37	41.8	89	40
100	46.4	34	44.3	96	36	43.4	94	37	41.2	89	38
102	46.8	30	44.3	95	34	43.5	93	37	41.4	89	37
104	46.6	29	44.9	96	33	43.5	93	36	41.7	90	37
Mean for weeks											
1-13	24.2		24.7	102		24.9	103		25.2	104	
14-52	36.8		35.7	97		36.7	100		36.7	100	
53-104	47.3		45.2	96		44.0	93		42.2	89	

Pathology and Statistical Analyses

This section describes the statistically significant or biologically noteworthy changes in the incidences of malignant lymphoma and of neoplasms and/or nonneoplastic lesions of the nose, liver, and ovary. Summaries of the incidences of neoplasms and nonneoplastic lesions, individual animal tumor diagnoses, statistical analyses of primary neoplasms that occurred with an incidence of at least 5% in at least one animal group, and historical incidences for the neoplasms mentioned in this section are presented in Appendix C for male mice and Appendix D for female mice.

Nose: The incidences of olfactory epithelial degeneration in 1,000 and 2,000 ppm males and females were significantly greater than in the chamber controls

(Tables 13, C5, and D5). Degeneration of the olfactory epithelium was minimal to mild in severity and occurred in the dorsal meatus of Level II; in a few mice, Level III was also involved. Affected olfactory epithelium was characterized by fewer layers of sensory cells, which were often disorganized, and was irregular in thickness. In some mice, only sustentacular and basal cell layers persisted, or ciliated, columnar, respiratory-like epithelium replaced areas of the olfactory epithelium. In some areas, only a thin layer of fusiform cells covered the surface; in others, the basal cells remained. Two 1,000 ppm females, one 2,000 ppm male, and one 2,000 ppm female had necrosis of the olfactory epithelium. Necrotic olfactory epithelium had pyknotic or karyorrhectic nuclei and dense eosinophilic cytoplasm.

TABLE 13
Incidences of Nonneoplastic Lesions of the Nose of Mice in the 2-Year Inhalation Study of Isobutyraldehyde

	Chamber Control	500 ppm	1,000 ppm	2,000 ppm
Male				
Number Examined Microscopically	50	50	50	50
Olfactory Epithelium, Degeneration ^a	0	0	11** (1.1) ^b	45** (1.4)
Olfactory Epithelium, Necrosis	0	0	0	1 (2.0)
Female				
Number Examined Microscopically	50	50	50	50
Olfactory Epithelium, Degeneration	1 (1.0)	1 (2.0)	27** (1.1)	49** (1.6)
Olfactory Epithelium, Necrosis	0	0	2 (3.0)	1 (1.0)

** Significantly different ($P \leq 0.01$) from the chamber control group by the logistic regression test

^a Number of animals with lesion

^b Average severity grade of lesions in affected animals: 1= minimal, 2= mild, 3= moderate, 4= marked

Malignant Lymphoma: The incidences of malignant lymphoma in male and female mice exposed to 2,000 ppm were slightly increased compared to the chamber controls (males: chamber control, 1/50; 500 ppm, 5/50; 1,000 ppm, 1/50; 2,000 ppm, 6/50; females: 12/50, 13/50, 12/50, 19/50; Tables C3 and D3). The only significant increase was in 2,000 ppm males, but this neoplasm incidence was well within the range of historical control values (Table C4). The incidence in chamber control males was also less than the average historical incidence.

Liver: Compared to chamber controls, the incidence of hepatocellular adenoma or carcinoma (combined) in male mice exposed to 2,000 ppm was significantly decreased (27/49, 25/50, 26/50, 18/50; Table C3). The incidences in all groups were within the historical control range for 2-year NTP inhalation studies [358/947 (37.8% ± 12.5%); range, 11%-60%].

Ovary: There were five cystadenomas and two cystadenocarcinomas in the 500 ppm females and two cystadenomas in the 2,000 ppm females (Table 14). The incidences in the 500 ppm group exceeded the historical control ranges in 2-year NTP inhalation studies for cystadenoma and for cystadenocarcinoma (Tables 14 and D4b); however, in a subcutaneous study (NTP, 1999) that has not yet been included in

the database, as many as 4/46 (9%) cystadenomas occurred in a control group. Neoplasms of epithelial origin (i.e., cystadenoma and tubulostromal adenoma) are the most common ovarian neoplasms that occur spontaneously in the B6C3F₁ mouse (Alison and Morgan, 1987). Generally, in NTP studies in which chemical-associated increased incidences of ovarian neoplasms have occurred, the most common neoplasm types included granulosa cell tumors, tubular adenomas, and/or benign mixed tumors (neoplasms with both a tubular cell component and interspersed stromal component) (Maronpot, 1987; NTP, 1988a; NTP, 1989). Ovarian atrophy was also noted in these studies and is thought to be important in the pathogenesis of ovarian neoplasm development. No ovarian atrophy related to isobutyraldehyde exposure was noted in the present study. Although the incidences of ovarian cystadenoma and cystadenocarcinoma in the 500 ppm females in this study were outside the historical control ranges, incidences of these neoplasms are higher in contemporary studies; also, there were no increases in the incidences of these neoplasms in the 1,000 ppm group, and the number of cystadenomas in the 2,000 ppm group was less than that in the 500 ppm group. Therefore, the marginally increased incidences in the 500 ppm group were not considered related to isobutyraldehyde exposure.

TABLE 14
Incidences of Neoplastic and Nonneoplastic Lesions of the Ovary of Female Mice in the 2-Year Inhalation Study of Isobutyraldehyde

	Chamber Control	500 ppm	1,000 ppm	2,000 ppm
Number examined microscopically	50	49	50	50
Cyst ^a	13 (2.0) ^b	15 (2.1)	14 (2.4)	18 (2.5)
Cystadenoma ^c	1	5	0	2
Cystadenocarcinoma ^d	0	2	0	0

^a Number of animals with lesion

^b Average severity grade of lesions in affected animals: 1= minimal; 2= mild; 3= moderate; 4= marked

^c Historical incidence for 2-year NTP inhalation studies with chamber controls (mean ± standard deviation): 15/921 (1.6% ± 1.8%); range, 0%-6%

^d Historical incidence: 1/921 (0.1% ± 0.2%); range, 0%-1%

GENETIC TOXICOLOGY

Isobutyraldehyde (up to 10,000 µg/plate) was tested in two independent *Salmonella typhimurium* gene mutation assays (Table E1; Mortelmans *et al.*, 1986). Results were negative for strains TA97, TA98, TA100, TA102, TA1535, and TA1537, with and without varying concentrations of rat and hamster liver S9 enzymes. In strain TA104 (study 2), an equivocal response was produced only in the presence of rat liver S9. Isobutyraldehyde (62.5 to 1,000 µg/mL) was strongly mutagenic in the mouse lymphoma assay in the absence of S9; the assay was not conducted with S9 (Table E2). In cytogenetic tests with cultured Chinese hamster ovary cells, isobutyraldehyde induced a strong, dose-related increase in sister chromatid exchanges, with and without S9 (Table E3). In the absence of S9, positive responses were noted for isobutyraldehyde concentrations of 5 to 500 µg/mL; cell cycle delay occurred at the 250 and 500 µg/mL concentrations in the second trial without S9, and culture times were extended accordingly. With S9, doses of 160 to 1,250 µg/mL produced significant increases in sister chromatid exchanges; no cell cycle delay was noted at any of the doses tested in the presence of S9. Results of the chromosomal aberrations test in cultured Chinese hamster ovary cells (Table E4) were also positive, but only in the absence of S9. With S9, the first trial gave negative results and the second trial was considered to be questionable, based on an increase in the percentage of cells with chromosomal aberrations that was seen at the middle dose of 750 µg/mL. None of the Chinese hamster ovary cell cultures in this test required an extended period of incubation to offset chemical-induced cell cycle delay.

Isobutyraldehyde did not induce sex-linked recessive lethal mutations in germ cells of male *Drosophila melanogaster* administered isobutyraldehyde in feed (80,000 ppm) or by injection (50,000 ppm) (Table E5; Woodruff *et al.*, 1985).

Results of *in vivo* tests for genetic damage induced in mammals by isobutyraldehyde were mixed, and the apparent contradictions in the data are not easily explained. Results of a test for induction of chromo-

somal aberrations in mouse bone marrow following a single intraperitoneal injection of isobutyraldehyde were clearly positive in each of two trials (Table E6), thus confirming *in vivo* the response observed in cultured Chinese hamster ovary cells exposed to isobutyraldehyde *in vitro*. In this test, increasing doses of isobutyraldehyde produced increasing frequencies of aberrant cells. However, significant increases in the frequency of aberrant cells were seen only at doses that produced notable clinical signs of toxicity, and no significant increases in chromosomal aberrations were observed below 1,500 mg/kg. The highest viable dose tested was 1,750 mg/kg. In contrast to the positive results in the chromosomal aberrations assay (in which the total duration of exposure was 17 hours), negative results were obtained in two independent mouse bone marrow micronucleus tests with isobutyraldehyde administered three times at 24-hour intervals (Table E7). The highest dose used in these mouse bone marrow micronucleus tests was 1,250 mg/kg, which gave a higher total dose (3,750 mg/kg) over the 72-hour exposure period, but a lower single individual dose compared with the chromosomal aberrations study. In addition, a rat bone marrow micronucleus test was conducted with isobutyraldehyde, using the same protocol as the mouse study, and results were also negative (Table E7). The micronucleus test indirectly measures numerical and structural chromosome damage. Therefore, the negative micronucleus data are somewhat problematic in light of the positive results from the chromosomal aberrations assay, which demonstrated the presence of structural chromosomal damage in mouse bone marrow cells after isobutyraldehyde exposure. However, it is likely that the highest single dose is an important factor in the assessment of the *in vivo* genetic damage produced by this unstable reactive chemical in these tests. The chemical characteristics of isobutyraldehyde may negate the concept of a total accumulated dose and, therefore, it must be considered that a single exposure to 1,250 mg/kg isobutyraldehyde would likely be insufficient (based on the chromosome aberration data) to produce a detectable response in the micronucleus assay.

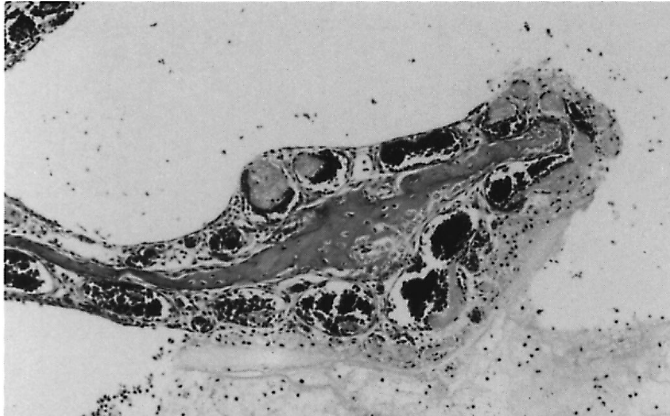

PLATE 1

Necrosis of the respiratory epithelium lining of the nasoturbinates and accumulation of acute inflammatory exudate in the nasal cavity lumen of a male F344/N rat exposed to 8,000 ppm isobutyraldehyde by inhalation for 13 weeks. H&E; 40×

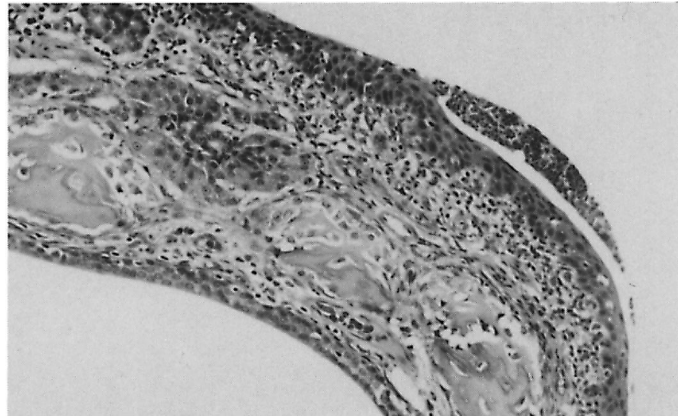

PLATE 2

Mild turbinate bone osteodystrophy accompanied by squamous metaplasia of the respiratory epithelium lining of the nasoturbinates and accumulation of exudate in a male F344/N rat exposed to 4,000 ppm isobutyraldehyde by inhalation for 13 weeks. H&E; 66×

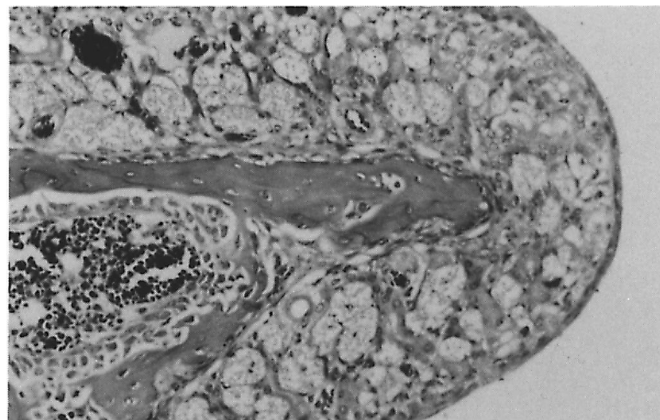

PLATE 3

Mild turbinate bone osteodystrophy accompanied by squamous metaplasia of the respiratory epithelium lining of the maxilloturbinates of a male F344/N rat exposed to 4,000 ppm isobutyraldehyde by inhalation for 13 weeks. H&E; 66×

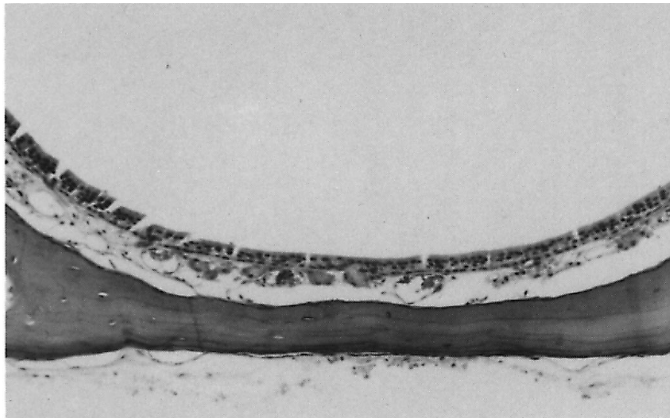

PLATE 4

Mild degeneration of the olfactory epithelium in the dorsal wall of level II of a female F344/N rat exposed to 2,000 ppm isobutylaldehyde by inhalation for 2 years. Affected olfactory epithelium is characterized by fewer layers of sensory cells, which are disorganized and irregular. H&E; 50×



PLATE 5

Olfactory epithelium in the dorsal wall of level II of a female F344/N chamber control rat from the 2-year study. Compare with the olfactory epithelium in Plate 4. H&E; 50×

DISCUSSION AND CONCLUSIONS

Isobutyraldehyde, a branched alkyl aldehyde, was nominated by the National Cancer Institute for toxicity and carcinogenicity testing by the NTP. Reasons for nomination and selection of isobutyraldehyde for study included its high production volume, its use as a chemical intermediate and food flavoring agent, its high potential for human exposure, suspicion of carcinogenicity due to an increased incidence of cancer at an aldehyde manufacturing plant where workers were exposed to isobutyraldehyde and other aldehydes, its structural relationship to formaldehyde (a nasal carcinogen in rats), and the lack of toxicity and carcinogenicity studies on isobutyraldehyde in animals. Inhalation toxicity and carcinogenicity studies were conducted by exposing male and female F344/N rats and B6C3F₁ mice to isobutyraldehyde vapors for 13 weeks or 2 years. The inhalation route of exposure was chosen because it is one of the routes by which humans could be exposed and because of the instability of isobutyraldehyde in feed and water.

In the 13-week inhalation studies, the target system for toxicity in rats was the upper respiratory tract (larynx, trachea, nasal mucosa, and nasal turbinate bone). The target organ for toxicity in mice was the nose (nasal mucosa and turbinate bone). The lesions consisted of acute inflammation, epithelial degeneration, necrosis, and squamous metaplasia in the affected site of the respiratory system. Respiratory tract lesions occurred at exposure concentrations of 2,000 ppm or greater in rats and 1,000 ppm or greater in mice.

Based on the presence of minimal and non-life-threatening nasal lesions in rats and mice in the 2,000 ppm groups, 2,000 ppm was considered as the minimally toxic exposure concentration. Accordingly, exposure concentrations selected for the 2-year studies with rats and mice were 0, 500, 1,000, and 2,000 ppm. These exposure concentrations were considered sufficient for determining the carcinogenic potential of isobutyraldehyde. These concentrations were estimated to give doses of 0.4, 0.8, or 1.6 mg isobutyraldehyde per kilogram body weight per day

for rats and 0.5, 1.0, or 2 mg/kg for mice. The estimate for rats was based on a 6-hour exposure period per day, a respiratory volume of 260 mL per minute, and mean body weights of 350 g for males and 270 g for females. The calculation for mice was based on a 6-hour exposure period per day, a respiratory volume of 44 mL per minute, and mean body weight of 42 g for males and females (Bond, 1989). Over 50% of male and 70% of female rats and over 80% of male and female mice lived long enough (91 weeks) for isobutyraldehyde to have shown any carcinogenic potential. Additionally, the lower mean body weights observed for 1,000 and 2,000 ppm female mice and the increased incidences of chemical-related nasal lesions observed in the 1,000 and 2,000 ppm rat and mouse groups indicate that the minimally toxic exposure concentration had been achieved.

In the 2-year rat study, no increase in neoplasm incidence that could be attributed to exposure to isobutyraldehyde was observed at any site even though three rats (one male each at 1,000 and 2,000 ppm and one female at 500 ppm) had nasal neoplasms. Spontaneous nasal neoplasms occur rarely in chamber control F344/N rats in the NTP historical database. In all 2-year NTP inhalation studies, one nasal adenoma occurred in 646 males, and one nasal fibrosarcoma was observed in 645 females. Because these neoplasms were of different histogenic origin, they are considered to be spontaneous rather than related to isobutyraldehyde. Although spontaneous neoplasms of the nasal cavity are uncommon, chemical-associated increased incidences have been observed in rats in 10 NTP studies. In general, nasal neoplasm incidences were high in these studies, and malignant neoplasms of mesenchymal origin were only observed in the studies with extremely high nasal neoplasm incidences. Furthermore, in none of those studies were neoplasms of the vomeronasal organ observed. Because there was no exposure-related response, and the neoplasms observed in this study were of different histogenic origin, they were not considered related to isobutyraldehyde exposure.

There were exposure-related increases in the incidences of squamous metaplasia and suppurative inflammation of the nasal respiratory epithelium as well as degeneration of the nasal olfactory epithelium. The increased incidences of squamous metaplasia were significant in 1,000 and 2,000 ppm males and females and in 500 ppm females. The increased incidences of inflammation and degeneration were significant in the 2,000 ppm groups.

In the 2-year mouse study, no increase that could be attributed to exposure to isobutyraldehyde in neoplasm incidence was observed at any site. In male and female mice, there were exposure-related increases in the incidences of degeneration of the nasal olfactory epithelium; the incidences were significant in the 1,000 and 2,000 ppm mice.

In contrast to other aldehydes (formaldehyde, acetaldehyde, and malonaldehyde) (IARC, 1985, 1995; NTP, 1988b), isobutyraldehyde is not a rodent carcinogen. This finding is not surprising, because isobutyraldehyde is oxidatively deformed to propylene and formic acid. Propylene was tested by the NTP in F344/N rats and B6C3F₁ mice and was found to be noncarcinogenic in both species (NTP, 1985). No information was found on the carcinogenicity of formic acid. Formic acid is excreted in urine as formate or bicarbonate. Formate is metabolized in the rat via the one carbon pool and/or via a catalase-peroxidative pathway. Oxidation occurs in various organs and tissues, including the liver and lungs. The end products of metabolism are water and carbon dioxide (Katz and Guest, 1994).

The nonneoplastic nasal lesions observed in rats and mice in the 13-week studies are characteristic of exposure to aldehydes and other irritants by inhalation. The nasal epithelium of Wistar rats exposed to 1,000 or 2,200 ppm acetaldehyde 6 hours per day, 5 days per week, for 4 weeks showed degeneration, with or without hyperplasia and metaplasia (Appleman *et al.*, 1982). Exposure of Wistar rats, Syrian golden hamsters, and Dutch rabbits to 0.4 to 4.9 ppm acrolein vapor 6 hours per day, 5 days per week, for 13 weeks caused hyperplasia and metaplasia of the epithelial lining of the respiratory tract and nasal irritation (Feron *et al.*, 1978). F344/N rats exposed to 125, 250, 500, or 1,000 ppb glutaraldehyde 6 hours per day, 5 days per week, for 13 weeks had hyperplasia and squamous

metaplasia of the nasal respiratory and olfactory epithelia. Similarly exposed B6C3F₁ mice had squamous metaplasia of the larynx, suppurative inflammation in the anterior part of the nose, and minimal squamous metaplasia of the nasoturbinate (NTP, 1993). Exposure of B6C3F₁ mice to 14.3 ppm formaldehyde vapor for 6 hours per day, 5 days per week, for up to 24 months followed by a 6-month recovery period caused dysplasia and squamous metaplasia of the respiratory epithelium and purulent and seropurulent rhinitis and atrophy of the olfactory epithelium (Kerns *et al.*, 1983a). In addition to these lesions, similarly exposed F344/N rats also had goblet cell metaplasia of the olfactory epithelium, respiratory epithelium hyperplasia, squamous epithelial hyperplasia, squamous atypia, and papillary hyperplasia (Kerns *et al.*, 1983b).

Two-year exposure to isobutyraldehyde in rats and mice induced only nonneoplastic nasal lesions, ranging from respiratory epithelial squamous metaplasia to olfactory epithelial degeneration and inflammation. These changes are considered to be nonspecific defensive or adaptive responses to chronic exposure to isobutyraldehyde by inhalation. The proximity of the surface of the nasal airways to the inhaled airflow makes these epithelia prime targets for toxicant-induced damage (Harkema and Morgan, 1996a). The response of these tissues depends on the chemical structure of the toxicant, its site of deposition in the nose (i.e., airflow-driven deposition), potential metabolic activation (particularly in the olfactory epithelium), and the inherent sensitivity of the cell or tissue (Harkema and Morgan, 1996a, 1996b). An anterior-posterior gradation in severity of nasal lesions is particularly evident in rats exposed by inhalation to water-soluble irritants (Jiang *et al.*, 1986; Maronpot *et al.*, 1986; Harkema, 1990); this gradient was seen in these studies. In fact, in the 2-year studies, isobutyraldehyde-exposed rats had inflammatory and metaplastic changes in the respiratory epithelium, while exposed rats and mice had only slight cellular degradation in the olfactory epithelium.

The usual sequence of events following exposure to noxious air contaminants that overcome airway defenses are tissue degeneration and necrosis, followed by rapid cell proliferation and migration to repair defects in the epithelial lining, and, finally, restoration of the epithelial lining or adaptation

(metaplasia) (Jiang *et al.*, 1986; Boorman *et al.*, 1990). This pattern was observed in the current isobutyraldehyde studies, and a similar pattern of events has been observed in rats, mice, and other species exposed to formaldehyde and other aldehydes (Maronpot *et al.*, 1986; Boorman *et al.*, 1990). In regard to respiratory tract lesions observed in mice, Maronpot *et al.* (1986) concluded that at higher concentrations, there was sufficient penetration of formaldehyde vapors into the respiratory tract to produce laryngeal and tracheal lesions (i.e., beyond the nasal cavity, which was the main target organ at the lower exposure concentrations).

In the 13-week studies, in which the range of exposure concentrations was even broader than in the 2-year studies (up to 8,000 ppm versus up to 2,000 ppm), the upper respiratory tract lesions were more prominent and extensive. While the nasal cavity was the primary site of toxicity in rats and mice, the mucosal larynx and trachea were affected only in the 8,000 ppm rat groups. The isobutyraldehyde-related nasal inflammatory process was deep and involved the nasal turbinate bones (i.e., mild osteodystrophy) following exposure of animals to 4,000 or 8,000 ppm.

Formaldehyde, a structurally related chemical classified as an irritant, induces respiratory epithelial proliferation with or without squamous metaplasia and inflammation. These phenomena are the result of region-specific epithelial cytotoxicity (Boorman *et al.*, 1990; Harkema and Morgan, 1996a). Although formaldehyde induced nasal neoplasms in the same regions where the nonneoplastic lesions occurred in the current 2-year study, the squamous metaplasia was not regarded as a preneoplastic change unless it was accompanied by dysplastic lesions (Harkema and Morgan, 1996a). Exposure to isobutyraldehyde resulted in no cell proliferation, dysplasia, or neoplasia. Additionally, the nasal tissue reaction to formaldehyde exposure was severe, whereas it was minimal in response to isobutyraldehyde.

Regarding olfactory mucosal toxicity, Gaskell (1990) classified olfactory toxins as direct- or indirect-acting chemicals. For a direct-acting chemical, the parent compound is toxic to the olfactory epithelium. Alternatively, for chemicals acting indirectly, the chemical is metabolized to a toxic intermediate either in the olfactory epithelium or in a distant organ and transported via the bloodstream to the olfactory

epithelium, where the metabolite has a toxic effect. Direct-acting gaseous irritants induce lesions in the olfactory epithelium (particularly the dorsal meatal anteriodorsal extension of this mucosa) as well as in the respiratory epithelium (Jiang *et al.*, 1986; Gaskell, 1990). By contrast, indirect-acting chemicals usually induce lesions in all or a large portion of the olfactory epithelium, while the respiratory epithelium is typically spared (Gaskell, 1990). The olfactory changes in the present case may therefore be regarded as a direct effect of isobutyraldehyde.

Morgan (1991) used the following nonneoplastic categories in order to clarify the nature of nonneoplastic lesions in the olfactory mucosa: degeneration, inflammation, regeneration/repair, adaptation, and proliferation. The degenerated olfactory epithelium sloughs, leaving a thin layer of basal cells needed for regeneration. Secondary atrophy of the nerve bundles derived from the affected sensory cells has been described following exposure to direct-acting toxins [e.g., acetaldehyde and formaldehyde (NTP, unpublished data)], whereas the bundles remain intact following exposure to indirect toxins (e.g., 3-methylindole and 3-methylfuran) (Gaskell, 1990). Mice exposed to formaldehyde (a direct-acting toxin) developed minimal to mild degradation of olfactory epithelium and replacement by respiratory epithelium (Maronpot *et al.*, 1986). The olfactory epithelium of the rat has also been reported to be affected by formaldehyde (Kerns *et al.*, 1983b).

In the present studies, the degeneration of the olfactory mucosa was generally limited to the dorsal meatus of Level II but occasionally extended to Level III. No evidence for cell-specific vulnerability within the olfactory mucosa was found. In the most severe cases, only one remaining layer of olfactory sensory cells lined the cavity, but there was no damage to the underlying bone tissue.

Many factors affect the response of different species to inhaled chemicals. These include differences in the architecture of the nasal cavity and its size (which influence airflow patterns), regional intranasal deposition of inhaled particles, and the dose of the toxicant to various epithelial cell populations along the luminal surface (Harkema, 1990). Other factors contributing to species-specific responses include differences in respiratory rate, respiratory volume, amount of oral breathing, and level of metabolic

activity for xenobiotics (particularly in the olfactory epithelium) (Harkema, 1990).

A difference in the severity of responses of rats and mice was apparent after isobutyraldehyde exposure. In the 13-week study, both the respiratory and olfactory epithelia were affected in rats and mice, with extension of the damage to the trachea and larynx in rats. During the 2-year studies, the respiratory and olfactory epithelia were again affected in rats, but only the olfactory epithelium in mice was affected. This species difference has also been noted in formaldehyde-induced lesions (Kerns *et al.*, 1983b), and it has been attributed to differences between rats and mice in the depression of respiratory rate by this irritant gas (Boorman *et al.*, 1990). Formaldehyde-exposed rats have been shown to reduce their minute volume by 20%, compared to a reduction of 50% for mice; this suggests that the "dose" of formaldehyde available for absorption and local toxicity is greater in rats than in mice (Kerns *et al.*, 1983a).

Isobutyraldehyde gave positive results in *in vitro* and *in vivo* mammalian cell assays that measured chromosomal damage, while results from *Salmonella typhimurium* and *Drosophila melanogaster* mutagenicity tests were negative, indicating that isobutyraldehyde does not induce gene mutations. Despite the high levels of chromosomal damage (aberrations and sister chromatid exchanges) seen in cultured mammalian cells exposed to isobutyraldehyde, the *in vivo* data were not as clear, with contradictory results noted in the micronucleus and the chromosomal aberrations assays. It is possible that the highly reactive nature of isobutyraldehyde does not allow for accumulated dose effects and, therefore, the single highest dose that can be administered is critical to the observation of chromosomal effects. In the mouse bone marrow

chromosomal aberrations test, doses of 1,500 and 1,750 mg/kg produced marked increases in the percentage of aberrant cells in the bone marrow 17 hours after treatment. Marked clinical signs of toxicity were noted at these dose levels. In the micronucleus test, which indirectly measures chromosomal breakage and aneuploidy induction, multiple dosing was employed (three doses administered at 24-hour intervals) and due to toxicity, the highest single dose of isobutyraldehyde that could be administered in a 24-hour period was 1,250 mg/kg in one experiment and 625 mg/kg in another. No increases in micronucleated cells were observed in the bone marrow of treated mice, and this may have been a direct consequence of the lower doses that were employed in this assay. Rats treated with the same doses as mice also showed no increase in frequency of micronucleated cells. Therefore, it appears that isobutyraldehyde-induced chromosomal damage *in vivo* is detected only at doses that are highly toxic and are not compatible with long-term survival, and neither neoplasms nor cytogenetic damage is observed at exposure levels that permit long-term survival.

CONCLUSIONS

Under the conditions of these 2-year inhalation studies, there was *no evidence of carcinogenic activity** of isobutyraldehyde in male or female F344/N rats or male or female B6C3F₁ mice exposed to 500, 1,000, or 2,000 ppm.

In male and female rats, exposure to isobutyraldehyde induced squamous metaplasia and suppurative inflammation of the nasal respiratory epithelium and degeneration of the nasal olfactory epithelium. In male and female mice, exposure to isobutyraldehyde caused degeneration of the nasal olfactory epithelium.

* Explanation of Levels of Evidence of Carcinogenic Activity is on page 9. A summary of the Technical Reports Review Subcommittee comments and the public discussion on this Technical Report appears on page 11.

REFERENCES

- Alison, R.H., and Morgan, K.T. (1987). Ovarian neoplasms in F344 rats and B6C3F1 mice. *Environ. Health Perspect.* **73**, 91-106.
- Appleman, L.M., Woutersen, R.A., and Feron, V.J. (1982). Inhalation toxicity of acetaldehyde in rats. I. Acute and subacute studies. *Toxicology* **23**, 293-307.
- Armitage, P. (1971). *Statistical Methods in Medical Research*, pp. 362-365. John Wiley and Sons, New York.
- Ashby, J., and Tennant, R.W. (1991). Definitive relationships among chemical structure, carcinogenicity and mutagenicity for 301 chemicals tested by the U.S. NTP. *Mutat. Res.* **257**, 229-306.
- Bittersohl, V.G. (1974). Epidemiologische Untersuchungen über Krebserkrankungen bei Arbeiten mit Aldol und aliphatischen Aldehyden. *Arch. Geschwulstforsch.* **43**, 172-176.
- Bond, T.A. (1989). Factors modifying the disposition of inhaled organic compounds. In *Concepts in Inhalation Toxicology* (R.O. McClellan and R.F. Henderson, Eds.), pp. 249-270. Hemisphere Publishing Corporation, New York.
- Boorman, G.A., Montgomery, C.A., Jr., Eustis, S.L., Wolfe, M.J., McConnell, E.E., and Hardisty, J.F. (1985). Quality assurance in pathology for rodent carcinogenicity studies. In *Handbook of Carcinogen Testing* (H.A. Milman and E.K. Weisburger, Eds.), pp. 345-357. Noyes Publications, Park Ridge, NJ.
- Boorman, G.A., Morgan, K.T., and Uriah, L.C. (1990). Nose, larynx, and trachea. In *Pathology of the Fischer Rat. Reference and Atlas* (G.A. Boorman, S.L. Eustis, M.R. Elwell, C.A. Montgomery, Jr., and W.F. MacKenzie, Eds.), pp. 315-337. Academic Press, Inc., San Diego.
- Brabec, M.J. (1981). Aldehydes and Acetals. In *Patty's Industrial Hygiene and Toxicology*, 3rd revised ed. (G.D. Clayton and F.E. Clayton, Eds.), Vol. 2A, pp. 2629-2669. John Wiley and Sons, New York.
- Casanova, M., Morgan, K.T., Steinhagen, W.H., Everitt, J.I., Popp, J.A., and Heck, H.d'A. (1991). Covalent binding of inhaled formaldehyde to DNA in the respiratory tract of rhesus monkeys: Pharmacokinetics, rat-to-monkey interspecies scaling, and extrapolation to man. *Fundam. Appl. Toxicol.* **17**, 409-428.
- Casanova-Schmitz, M., David, R.M., and Heck, H.d'A. (1984). Oxidation of formaldehyde and acetaldehyde by NAD⁺-dependent dehydrogenases in rat nasal mucosal homogenates. *Biochem. Pharmacol.* **33**, 1137-1142.
- Caspary, W.J., Langenbach, R., Penman, B.W., Crespi, C., Myhr, B.C., and Mitchell, A.D. (1988). The mutagenic activity of selected compounds at the TK locus: rodent vs. human cells. *Mutat. Res.* **196**, 61-81.
- Chang, J.C.F., Gross, E.A., Swenberg, J.A., and Barrow, C.S. (1983). Nasal cavity deposition, histopathology, and cell proliferation after single or repeated formaldehyde exposures in B6C3F1 mice and F-344 rats. *Toxicol. Appl. Pharmacol.* **68**, 161-176.
- Chemical Economics Handbook* (1996). *Report Oxo Chemicals; Supply and Demand, United States, Consumption*, pp. 682.7000M, 682.7001E. SRI International, Menlo Park, CA.
- Code of Federal Regulations (CFR) **21**, Part 58.
- Code of Federal Regulations (CFR) **21**, § 172.515.
- Code of Federal Regulations (CFR) **40**, § 350.1.

- Code of Federal Regulations (CFR) **40**, § 372.65.
- Cox, D.R. (1972). Regression models and life-tables. *J. R. Stat. Soc.* **B34**, 187-220.
- Crawford, B.D. (1985). Perspectives on the somatic mutation model of carcinogenesis. In *Advances in Modern Environmental Toxicology. Mechanisms and Toxicity of Chemical Carcinogens and Mutagens* (M.A. Mehlman, W.G. Flamm, and R.J. Lorentzen, Eds.), pp. 13-59. Princeton Scientific Publishing Co., Princeton, NJ.
- Daubert, T.E., and Danner, R.P. (1989). *Physical and Thermodynamic Properties of Pure Chemicals: Data Compilation*. Hemisphere Publishing Corporation, New York.
- Dinse, G.E., and Haseman, J.K. (1986). Logistic regression analysis of incidental-tumor data from animal carcinogenicity experiments. *Fundam. Appl. Toxicol.* **6**, 44-52.
- Dinse, G.E., and Lagakos, S.W. (1983). Regression analysis of tumour prevalence data. *Appl. Statist.* **32**, 236-248.
- Dixon, W.J., and Massey, F.J., Jr. (1951). *Introduction to Statistical Analysis*, 1st ed., pp. 145-147. McGraw-Hill Book Company, New York.
- Dunn, O.J. (1964). Multiple comparisons using rank sums. *Technometrics* **6**, 241-252.
- Dunnnett, C.W. (1955). A multiple comparison procedure for comparing several treatments with a control. *J. Am. Stat. Assoc.* **50**, 1096-1121.
- Fenaroli's Handbook of Flavor Ingredients* (1975). 2nd ed., Vol. 2 (T.E. Furia and N. Bellanca, Eds.), p. 295. The Chemical Rubber Co., Cleveland, Ohio.
- Feron, V.J., Kruyssen, A., Til, H.P., and Immel, H.R. (1978). Repeated exposure to acrolein vapour: Subacute studies in hamsters, rats and rabbits. *Toxicology* **9**, 47-57.
- Florin, I., Rutberg, L., Curvall, M., and Enzell, C.R. (1980). Screening of tobacco smoke constituents for mutagenicity using the Ames' test. *Toxicology* **18**, 219-232.
- Food Chemical Codex (1972).
- Galloway, S.M., Armstrong, M.J., Reuben, C., Colman, S., Brown, B., Cannon, C., Bloom, A.D., Nakamura, F., Ahmed, M., Duk, S., Rimpo, J., Margolin, B.H., Resnick, M.A., Anderson, B., and Zeiger, E. (1987). Chromosome aberrations and sister chromatid exchanges in Chinese hamster ovary cells: Evaluations of 108 chemicals. *Environ. Mol. Mutagen.* **10** (Suppl. 10), 1-175.
- Gart, J.J., Chu, K.C., and Tarone, R.E. (1979). Statistical issues in interpretation of chronic bioassay tests for carcinogenicity. *J. Natl. Cancer Inst.* **62**, 957-974.
- Gaskell, B.A. (1990). Nonneoplastic changes in the olfactory epithelium—Experimental studies. *Environ. Health Perspect.* **85**, 275-289.
- Graedel, T.E., Hawkins, D.T., and Claxton, L.D. (1986). *Atmospheric Chemical Compounds: Sources, Occurrence, and Bioassay*, p. 732. Academic Press, Orlando, FL.
- Harkema, J.R. (1990). Comparative pathology of the nasal mucosa in laboratory animals exposed to inhaled irritants. *Environ. Health Perspect.* **85**, 231-238.
- Harkema, J.R., and Morgan, K.T. (1996a). Proliferative and metaplastic lesions in nonolfactory nasal epithelia induced by inhaled chemicals. In *Respiratory System* (T.C. Jones, D.L. Dungworth, and U. Mohr, Eds.), 2nd ed., pp. 18-28. Springer-Verlag, Berlin.
- Harkema, J.R., and Morgan, K.T. (1996b). Nonneoplastic lesions of olfactory mucosa. In *Respiratory System* (T.C. Jones, D.L. Dungworth, and U. Mohr, Eds.), 2nd ed., p. 28. Springer-Verlag, Berlin.
- Haseman, J.K. (1984). Statistical issues in the design, analysis and interpretation of animal carcinogenicity studies. *Environ. Health Perspect.* **58**, 385-392.

- Haseman, J.K., Huff, J., and Boorman, G.A. (1984). Use of historical control data in carcinogenicity studies in rodents. *Toxicol. Pathol.* **12**, 126-135.
- Hawley's Condensed Chemical Dictionary* (1987). 11th ed. (N.I. Sax and R.J. Lewis, Eds.), p. 654. Van Nostrand Reinhold, New York.
- Heck, H.d'A., Casanova, M., Steinhagen, W.H., Everitt, J.I., Morgan, K.T., and Popp, J.A. (1989). Formaldehyde toxicity: DNA-protein cross-linking studies in rats and nonhuman primates. In *Nasal Carcinogenesis in Rodents: Relevance to Human Risk* (V.J. Feron and M.C. Bosland, Eds.), pp. 159-164. Wageningen, Pudoc.
- Hollander, M., and Wolfe, D.A. (1973). *Nonparametric Statistical Methods*, pp. 120-123. John Wiley and Sons, New York.
- Hrudey, S.E., Gac, A., and Daignault, S.A. (1988). Potent odour-causing chemicals arising from drinking water disinfection. *Water Sci. Tech.* **20**, 55-61.
- International Agency for Research on Cancer (IARC) (1985). *IARC Monographs on the Evaluation of the Carcinogenic Risk of Chemicals to Humans. Alkyl Compounds, Aldehydes, Epoxides and Peroxides*, Vol. 36. IARC, Lyon, France.
- International Agency for Research on Cancer (IARC) (1995). *IARC Monographs on the Evaluation of the Carcinogenic Risk of Chemicals to Humans. Wood Dust and Formaldehyde*, Vol. 62. IARC, Lyon, France.
- Jiang, X.-Z., Morgan, K.T., and Beauchamp, R.O., Jr. (1986). Histopathology of acute and subacute nasal toxicity. In *Toxicology of the Nasal Passages* (C.S. Barrow, Ed.), pp. 51-66. Hemisphere Publishing Corp., Washington, DC.
- Jonckheere, A.R. (1954). A distribution-free *k*-sample test against ordered alternatives. *Biometrika* **41**, 133-145.
- Kaplan, E.L., and Meier, P. (1958). Nonparametric estimation from incomplete observations. *J. Am. Stat. Assoc.* **53**, 457-481.
- Katz, G.V., and Guest, D. (1994). Aliphatic carboxylic acids. In *Patty's Industrial Hygiene and Toxicology*, 4th ed. (G.D. Clayton and F.E. Clayton, Eds.), vol. 2, pp. 3523-3671. John Wiley and Sons, New York.
- Kerns, W.D., Pavkov, K.L., Donofrio, D.J., Gralla, E.J., and Swenberg, J.A. (1983a). Carcinogenicity of formaldehyde in rats and mice after long-term inhalation exposure. *Cancer Res.* **43**, 4382-4392.
- Kerns, W.D., Donofrio, D.J., and Pavkov, K.L. (1983b). The chronic effects of formaldehyde inhalation in rats and mice: A preliminary report. In *Formaldehyde Toxicity* (J.E. Gibson, Ed.), pp. 111-131. Hemisphere Publishing Corp., Washington, DC.
- McConnell, E.E., Solleveld, H.A., Swenberg, J.A., and Boorman, G.A. (1986). Guidelines for combining neoplasms for evaluation of rodent carcinogenesis studies. *JNCI* **76**, 283-289.
- McFee, A.F., Lowe, K.W., and San Sebastian, J.R. (1983). Improved sister-chromatid differentiation using paraffin-coated bromodeoxyuridine tablets in mice. *Mutat. Res.* **119**, 83-88.
- McKnight, B., and Crowley, J. (1984). Tests for differences in tumor incidence based on animal carcinogenesis experiments. *J. Am. Stat. Assoc.* **79**, 639-648.
- Margolin, B.H., Collings, B.J., and Mason, J.M. (1983). Statistical analysis and sample-size determinations for mutagenicity experiments with binomial responses. *Environ. Mutagen.* **5**, 705-716.
- Margolin, B.H., Resnick, M.A., Rimpo, J.Y., Archer, P., Galloway, S.M., Bloom, A.D., and Zeiger, E. (1986). Statistical analyses for in vitro cytogenetic assays using Chinese hamster ovary cells. *Environ. Mutagen.* **8**, 183-204.

- Margolin, B.H., Risko, K.J., Frome, E.L., and Tice, R.R. (1990). A general purpose statistical analysis program for micronucleus assay data. Appendix 2: Micronucleus data management and analysis version 1.4a. Integrated Laboratory Systems, Research Triangle Park, NC.
- Marhold, L. (1986). Preheld Prumyslove Toxicologie: Organické Latky. In *Avicenum*, p. 270. Prague, Czechoslovakia.
- Maronpot, R.R. (1987). Ovarian toxicity and carcinogenicity in eight recent National Toxicology Program studies. *Environ. Health Perspect.* **73**, 125-130.
- Maronpot, R.R., and Boorman, G.A. (1982). Interpretation of rodent hepatocellular proliferative alterations and hepatocellular tumors in chemical safety assessment. *Toxicol. Pathol.* **10**, 71-80.
- Maronpot, R.R., Miller, R.A., Clarke, W.J., Westerberg, R.B., Decker, J.R., and Moss, O.R. (1986). Toxicity of formaldehyde vapor in B6C3F1 mice exposed for 13 weeks. *Toxicology* **41**, 253-266.
- The Merck Index* (1989). 11th ed. (S. Budavari, Ed.), p. 811. Merck and Company, Rahway, NJ.
- Miller, J.A., and Miller, E.C. (1977). Ultimate chemical carcinogens as reactive mutagenic electrophiles. In *Origins of Human Cancer* (H.H. Hiatt, J.D. Watson, and J.A. Winsten, Eds.), pp. 605-627. Cold Spring Harbor Laboratory, Cold Spring Harbor, NY.
- Morgan, K.T. (1991). Approaches to the identification and recording of nasal lesions in toxicology studies. *Toxicol. Pathol.* **19**, 337-351.
- Morrison, D.F. (1976). *Multivariate Statistical Methods*, 2nd ed., pp. 170-179. McGraw-Hill Book Company, New York.
- Mortelmans, K., Haworth, S., Lawlor, T., Speck, W., Tainer, B., and Zeiger, E. (1986). *Salmonella* mutagenicity tests: II. Results from the testing of 270 chemicals. *Environ. Mutagen.* **8** (Suppl. 7), 1-119.
- Myhr, B., Bowers, L., and Caspary, W.J. (1985). Assays for the induction of gene mutations at the thymidine kinase locus in L5178Y mouse lymphoma cells in culture. In *Progress in Mutation Research: Evaluation of Short-term Tests for Carcinogens; Report of the International Programme on Chemical Safety's Collaborative Study on In vitro Assays* (J. Ashby, F.J. de Serres, M. Draper, M. Ishidate, Jr., B.H. Margolin, B.E. Matter, and M.D. Shelby, Eds.), Vol. 5, pp. 555-568. Elsevier Science Publishers, Amsterdam.
- National Cancer Institute (NCI) (1976). Guidelines for Carcinogen Bioassay in Small Rodents. Technical Report Series No. 1. NIH Publication No. 76-801. U.S. Department of Health, Education, and Welfare, Public Health Service, National Institutes of Health, Bethesda, MD.
- National Institute for Occupational Safety and Health (NIOSH) (1990). National Occupational Exposure Survey (1981-1983), unpublished provisional data as of July 1, 1990. NIOSH, Cincinnati, OH.
- National Institutes of Health (NIH) (1978). Open Formula Mouse and Rat Ration (NIH-07). Specifications NIH-11-1335. U.S. Department of Health, Education, and Welfare, Public Health Service, National Institutes of Health, Bethesda, MD.
- National Toxicology Program (NTP) (1983). National Toxicology Program (NTP) General Statement of Work for the Conduct of Toxicity and Carcinogenicity Studies in Laboratory Animals. Technical Protocol for Sperm Morphology and Vaginal Cytology Evaluation in Toxicity Testing for Rats and Mice. 10/31/82 version (updated October 1983). Research Triangle Park, NC.
- National Toxicology Program (NTP) (1985). Toxicology and Carcinogenesis Studies of Propylene (CAS No. 115-07-1) in F344/N Rats and B6C3F₁ Mice (Inhalation Studies). Technical Report Series No. 272. NIH No. 86-2528. U.S. Department of Health and Human Services, Public Health Service, National Institutes of Health, Research Triangle Park, NC.

- National Toxicology Program (NTP) (1988a). Toxicology and Carcinogenesis Studies of Nitrofurazone (CAS No. 59-87-0) in F344/N Rats and B6C3F₁ Mice (Feed Studies). Technical Report Series No. 337. NIH No. 88-2593. U.S. Department of Health and Human Services, Public Health Service, National Institutes of Health, Research Triangle Park, NC.
- National Toxicology Program (NTP) (1988b). Toxicology and Carcinogenesis Studies of Malonaldehyde, Sodium Salt (CAS No. 24382-04-5) in F344/N Rats and B6C3F₁ Mice (Gavage Studies). Technical Report Series No. 331. NIH No. 89-2587. U.S. Department of Health and Human Services, Public Health Service, National Institutes of Health, Research Triangle Park, NC.
- National Toxicology Program (NTP) (1989). Toxicology and Carcinogenesis Studies of Nitrofurantoin (CAS No. 67-20-9) in F344/N Rats and B6C3F₁ Mice (Feed Studies). Technical Report Series No. 341. NIH No. 89-2597. U.S. Department of Health and Human Services, Public Health Service, National Institutes of Health, Research Triangle Park, NC.
- National Toxicology Program (NTP) (1990). Assessment of Contact Hypersensitivity to Isobutyraldehyde in Female B6C3F₁ Mice. Report to the National Toxicology Program. Protocol IBA-0-1-CNM. Studies conducted at Immunotoxicology Program, Medical College of Virginia, Virginia Commonwealth University, Richmond, VA.
- National Toxicology Program (NTP) (1993). Toxicity Studies of Glutaraldehyde (CAS No. 111-30-8) Administered by Inhalation to F344/N Rats and B6C3F₁ Mice. Toxicity Report Series No. 25. NIH No. 93-3348. U.S. Department of Health and Human Services, Public Health Service, National Institutes of Health, Research Triangle Park, NC.
- National Toxicology Program (NTP) (1999). Toxicology and Carcinogenesis Studies of AZT and AZT/ α -Interferon A/D (CAS No. 30516-87-1) in B6C3F₁ Mice (Gavage Studies). Technical Report Series No. 469. NIH No. 99-3959. U.S. Department of Health and Human Services, Public Health Service, National Institutes of Health, Research Triangle Park, NC. (in press)
- Obe, G., and Beek, B. (1979). Mutagenic activity of aldehydes. *Drug Alcohol Depend.* **4**, 91-94.
- Patty's Industrial Hygiene and Toxicology* (1963). 2nd revised ed. (D.W. Fassett and D.D. Irish, Eds.), Vol. 2, p. 1966. John Wiley and Sons, New York.
- Patty's Industrial Hygiene and Toxicology* (1982). 3rd revised ed. (G.D. Clayton and F.E. Clayton, Eds.), Vol. 2C, pp. 4915-4916. John Wiley and Sons, New York.
- Registry of Toxic Effects of Chemical Substances (RTECS)* (1982). 1981-1982 Edition, Vol. 2 (D.V. Sweet, Ed.). U.S. Department of Health and Human Services, Public Health Service, Centers for Disease Control, National Institute for Occupational Safety and Health.
- Roberts, E.S., Vaz, A.D.N., and Coon, M.J. (1991). Catalysis by cytochrome P-450 of an oxidative reaction in xenobiotic aldehyde metabolism: Deformylation with olefin formation. *Proc. Natl. Acad. Sci.* **88**, 8963-8966.
- Sadtler Standard Spectra*. IR No. 696; NMR No. 9370. Sadtler Research Laboratories, Philadelphia.
- Sasaki, Y., and Endo, R. (1978). Mutagenicity of aldehyde in *Salmonella*. *Mutat. Res.* **54**, 251-252.

- Shelby, M.D., and Witt, K.L. (1995). Comparison of results from mouse bone marrow chromosome aberration and micronucleus tests. *Environ. Mol. Mutagen.* **25**, 302-313.
- Shelby, M.D., Erexson, G.L., Hook, G.J., and Tice, R.R. (1993). Evaluation of a three-exposure mouse bone marrow micronucleus protocol: Results with 49 chemicals. *Environ. Mol. Mutagen.* **21**, 160-179.
- Shirley, E. (1977). A non-parametric equivalent of Williams' test for contrasting increasing dose levels of a treatment. *Biometrics* **33**, 386-389.
- Sittig, M. (1994). *World-Wide Limits for Toxic and Hazardous Chemicals in Air, Water, and Soil*. Noyes Publications, Park Ridge, NJ.
- Smith, L., and Packer, L. (1972). Aldehyde oxidation in rat liver mitochondria. *Arch. Biochem. Biophys.* **148**, 270-276.
- Straus, D.S. (1981). Somatic mutation, cellular differentiation, and cancer causation. *JNCI* **67**, 233-241.
- Svintukhovskii, O.A. (1972). Toxicological characteristics of isobutyric aldehyde. *Toksikol. Gig. Prod. Neftekhim Proizod.*, **X**, 187-190.
- Tarone, R.E. (1975). Tests for trend in life table analysis. *Biometrika* **62**, 679-682.
- Tennant, R.W., Margolin, B.H., Shelby, M.D., Zeiger, E., Haseman, J.K., Spalding, J., Caspary, W., Resnick, M., Stasiewicz, S., Anderson, B., and Minor, R. (1987). Prediction of chemical carcinogenicity in rodents from *in vitro* genetic toxicity assays. *Science* **236**, 933-941.
- Tice, R.R., Boucher, R., Luke, C.A., and Shelby, M.D. (1987). Comparative cytogenetic analysis of bone marrow damage induced in male B6C3F1 mice by multiple exposures to gaseous 1,3-butadiene. *Environ. Mutagen.* **9**, 235-250.
- Williams, D.A. (1971). A test for differences between treatment means when several dose levels are compared with a zero dose control. *Biometrics* **27**, 103-117.
- Williams, D.A. (1972). The comparison of several dose levels with a zero dose control. *Biometrics* **28**, 519-531.
- Williams, R.T. (1959). *Detoxification Mechanisms. The Metabolism and Detoxication of Drugs, Toxic Substances and Other Organic Compounds*. 2nd ed. p. 97. John Wiley and Sons, New York.
- Woodruff, R.C., Mason, J.M., Valencia, R., and Zimmering, S. (1985). Chemical mutagenesis testing in *Drosophila*. V. Results of 53 coded compounds tested for the National Toxicology Program. *Environ. Mutagen.* **7**, 677-702.
- Zeiger, E., Haseman, J.K., Shelby, M.D., Margolin, B.H., and Tennant, R.W. (1990). Evaluation of four *in vitro* genetic toxicity tests for predicting rodent carcinogenicity: Confirmation of earlier results with 41 additional chemicals. *Environ. Mol. Mutagen.* **16** (Suppl. 18), 1-14.
- Zeiger, E., Anderson, B., Haworth, S., Lawlor, T., and Mortelmans, K. (1992). Salmonella mutagenicity tests: V. Results from the testing of 311 chemicals. *Environ. Mol. Mutagen.* **19** (Suppl. 21), 2-141.
- Zolotov, P.A. and Svintukhovskii, O.A. (1972). Determination of the maximum permissible concentration of isobutyric aldehyde in the air of the working zone [In Russian]. *Gig. Sanit.* **37**, 104-106.

APPENDIX A
SUMMARY OF LESIONS IN MALE RATS
IN THE 2-YEAR INHALATION STUDY
OF ISOBUTYRALDEHYDE

TABLE A1	Summary of the Incidence of Neoplasms in Male Rats in the 2-Year Inhalation Study of Isobutyraldehyde	59
TABLE A2	Individual Animal Tumor Pathology of Male Rats in the 2-Year Inhalation Study of Isobutyraldehyde	62
TABLE A3	Statistical Analysis of Primary Neoplasms in Male Rats in the 2-Year Inhalation Study of Isobutyraldehyde	78
TABLE A4	Historical Incidence of Adenoma of the Nose in Chamber Control Male F344/N Rats	83
TABLE A5	Summary of the Incidence of Nonneoplastic Lesions in Male Rats in the 2-Year Inhalation Study of Isobutyraldehyde	84

TABLE A1
Summary of the Incidence of Neoplasms in Male Rats in the 2-Year Inhalation Study of Isobutyraldehyde^a

	Chamber Control	500 ppm	1,000 ppm	2,000 ppm
Disposition Summary				
Animals initially in study	50	50	50	50
Early deaths				
Moribund	35	32	34	35
Natural deaths	3	3	5	5
Survivors				
Terminal sacrifice	12	15	11	10
Animals examined microscopically	50	50	50	50
Alimentary System				
Intestine large, colon	(50)	(49)	(49)	(50)
Polyp adenomatous			1 (2%)	
Intestine large, rectum	(50)	(47)	(49)	(50)
Polyp adenomatous		1 (2%)		
Intestine large, cecum	(47)	(49)	(48)	(48)
Intestine small, duodenum	(50)	(49)	(49)	(49)
Intestine small, ileum	(48)	(49)	(48)	(47)
Carcinoma	1 (2%)		1 (2%)	
Liver	(50)	(49)	(50)	(50)
Hepatocellular carcinoma		2 (4%)		
Mesentery	(11)	(12)	(8)	(10)
Oral mucosa		(3)	(2)	(2)
Squamous cell papilloma		1 (33%)		1 (50%)
Pharyngeal, squamous cell papilloma			1 (50%)	
Pancreas	(50)	(48)	(50)	(50)
Adenoma		1 (2%)		
Stomach, forestomach	(50)	(49)	(50)	(50)
Leiomyosarcoma		1 (2%)		
Stomach, glandular	(50)	(49)	(50)	(50)
Cardiovascular System				
Heart	(50)	(49)	(50)	(50)
Endocrine System				
Adrenal cortex	(50)	(49)	(50)	(50)
Adrenal medulla	(49)	(49)	(50)	(50)
Pheochromocytoma malignant	3 (6%)		1 (2%)	1 (2%)
Pheochromocytoma benign	7 (14%)	11 (22%)	9 (18%)	11 (22%)
Bilateral, pheochromocytoma benign	4 (8%)	1 (2%)	3 (6%)	4 (8%)
Islets, pancreatic	(50)	(49)	(50)	(50)
Adenoma	1 (2%)	3 (6%)	1 (2%)	3 (6%)
Carcinoma	2 (4%)	1 (2%)	1 (2%)	1 (2%)
Pituitary gland	(50)	(49)	(49)	(50)
Pars distalis, adenoma	41 (82%)	27 (55%)	37 (76%)	34 (68%)
Thyroid gland	(50)	(49)	(50)	(50)
Bilateral, C-cell, adenoma				1 (2%)
C-cell, adenoma	1 (2%)	1 (2%)	4 (8%)	1 (2%)
C-cell, adenoma, multiple		1 (2%)		
C-cell, carcinoma	3 (6%)	1 (2%)	1 (2%)	1 (2%)
Follicular cell, carcinoma			2 (4%)	

TABLE A1
Summary of the Incidence of Neoplasms in Male Rats in the 2-Year Inhalation Study of Isobutyraldehyde (continued)

	Chamber Control	500 ppm	1,000 ppm	2,000 ppm
General Body System				
Peritoneum	(2)			(1)
Genital System				
Epididymis	(50)	(49)	(50)	(50)
Preputial gland	(50)	(49)	(50)	(50)
Adenoma		2 (4%)	1 (2%)	
Carcinoma	2 (4%)	2 (4%)	4 (8%)	3 (6%)
Prostate	(50)	(49)	(50)	(50)
Seminal vesicle	(50)	(49)	(50)	(50)
Testes	(50)	(50)	(50)	(50)
Bilateral, interstitial cell, adenoma	18 (36%)	31 (62%)	20 (40%)	16 (32%)
Interstitial cell, adenoma	12 (24%)	12 (24%)	10 (20%)	20 (40%)
Hematopoietic System				
Bone marrow	(50)	(49)	(50)	(50)
Lymph node	(15)	(10)	(6)	(7)
Lymph node, bronchial	(50)	(46)	(49)	(50)
Lymph node, mandibular	(46)	(46)	(44)	(44)
Lymph node, mesenteric	(50)	(49)	(50)	(50)
Lymph node, mediastinal	(49)	(49)	(50)	(50)
Spleen	(50)	(49)	(50)	(50)
Fibrosarcoma			1 (2%)	
Hemangiosarcoma				1 (2%)
Thymus	(50)	(49)	(50)	(49)
Thymoma benign			1 (2%)	
Thymoma malignant			2 (4%)	
Integumentary System				
Mammary gland	(50)	(49)	(50)	(50)
Fibroadenoma	1 (2%)	2 (4%)	1 (2%)	1 (2%)
Skin	(50)	(50)	(50)	(50)
Basal cell adenoma		1 (2%)		
Keratoacanthoma	1 (2%)	4 (8%)	3 (6%)	2 (4%)
Schwannoma malignant			1 (2%)	
Squamous cell papilloma		2 (4%)		
Trichoepithelioma		1 (2%)	1 (2%)	
Epidermis, keratoacanthoma	1 (2%)			
Sebaceous gland, adenoma	1 (2%)			
Subcutaneous tissue, fibroma	3 (6%)	1 (2%)	1 (2%)	4 (8%)
Subcutaneous tissue, fibrosarcoma		1 (2%)	1 (2%)	
Subcutaneous tissue, lipoma	1 (2%)		1 (2%)	
Subcutaneous tissue, sarcoma				1 (2%)
Musculoskeletal System				
Skeletal muscle		(1)		
Sarcoma		1 (100%)		

TABLE A1
Summary of the Incidence of Neoplasms in Male Rats in the 2-Year Inhalation Study of Isobutyraldehyde (continued)

	Chamber Control	500 ppm	1,000 ppm	2,000 ppm
Nervous System				
Brain	(50)	(50)	(50)	(50)
Spinal cord		(1)	(1)	(1)
Schwannoma malignant			1 (100%)	
Respiratory System				
Lung	(50)	(49)	(50)	(50)
Alveolar/bronchiolar adenoma	1 (2%)			2 (4%)
Epithelioma benign			1 (2%)	
Nose	(50)	(49)	(49)	(50)
Adenoma			1 (2%)	
Vomeronasal organ, adenoma				1 (2%)
Pleura	(1)		(1)	
Special Senses System				
Zymbal's gland	(2)	(1)	(1)	(1)
Carcinoma	1 (50%)	1 (100%)	1 (100%)	
Urinary System				
Kidney	(50)	(49)	(50)	(50)
Urinary bladder	(50)	(48)	(50)	(50)
Transitional epithelium, carcinoma		1 (2%)		
Systemic Lesions				
Multiple organs ^b	(50)	(50)	(50)	(50)
Leukemia mononuclear	33 (66%)	32 (64%)	23 (46%)	34 (68%)
Lymphoma malignant	1 (2%)	1 (2%)		
Mesothelioma benign				1 (2%)
Mesothelioma malignant	2 (4%)		1 (2%)	1 (2%)
Neoplasm Summary				
Total animals with primary neoplasms ^c	50	49	49	50
Total primary neoplasms	141	147	138	145
Total animals with benign neoplasms	47	49	46	49
Total benign neoplasms	93	103	97	102
Total animals with malignant neoplasms	40	38	33	36
Total malignant neoplasms	48	44	41	43

^a Number of animals examined microscopically at the site and the number of animals with neoplasm

^b Number of animals with any tissue examined microscopically

^c Primary neoplasms: all neoplasms except metastatic neoplasms

TABLE A3
Statistical Analysis of Primary Neoplasms in Male Rats in the 2-Year Inhalation Study of Isobutyraldehyde

	Chamber Control	500 ppm	1,000 ppm	2,000 ppm
Adrenal Medulla: Benign Pheochromocytoma				
Overall rate ^a	11/49 (22%)	12/49 (24%)	12/50 (24%)	15/50 (30%)
Adjusted rate ^b	59.1%	57.3%	60.7%	67.3%
Terminal rate ^c	5/12 (42%)	7/15 (47%)	5/11 (45%)	4/10 (40%)
First incidence (days)	663	579	523	581
Life table test ^d	P= 0.051	P= 0.513N	P= 0.392	P= 0.094
Logistic regression test ^d	P= 0.059	P= 0.585	P= 0.340	P= 0.084
Cochran-Armitage test ^d	P= 0.224			
Fisher exact test ^d		P= 0.500	P= 0.522	P= 0.266
Adrenal Medulla: Malignant Pheochromocytoma				
Overall rate	3/49 (6%)	0/49 (0%)	1/50 (2%)	1/50 (2%)
Adjusted rate	12.8%	0.0%	3.6%	2.9%
Terminal rate	0/12 (0%)	0/15 (0%)	0/11 (0%)	0/10 (0%)
First incidence (days)	642	— ^e	616	582
Life table test	P= 0.380N	P= 0.116N	P= 0.380N	P= 0.411N
Logistic regression test	P= 0.296N	P= 0.115N	P= 0.321N	P= 0.313N
Cochran-Armitage test	P= 0.290N			
Fisher exact test		P= 0.121N	P= 0.301N	P= 0.301N
Adrenal Medulla: Benign or Malignant Pheochromocytoma				
Overall rate	14/49 (29%)	12/49 (24%)	12/50 (24%)	16/50 (32%)
Adjusted rate	64.5%	57.3%	60.7%	68.3%
Terminal rate	5/12 (42%)	7/15 (47%)	5/11 (45%)	4/10 (40%)
First incidence (days)	642	579	523	581
Life table test	P= 0.093	P= 0.260N	P= 0.542N	P= 0.176
Logistic regression test	P= 0.121	P= 0.320N	P= 0.577N	P= 0.205
Cochran-Armitage test	P= 0.340			
Fisher exact test		P= 0.410N	P= 0.387N	P= 0.440
Pancreatic Islets: Adenoma				
Overall rate	1/50 (2%)	3/49 (6%)	1/50 (2%)	3/50 (6%)
Adjusted rate	6.3%	10.4%	7.7%	18.5%
Terminal rate	0/12 (0%)	0/15 (0%)	0/11 (0%)	1/10 (10%)
First incidence (days)	706	616	720	636
Life table test	P= 0.202	P= 0.335	P= 0.745	P= 0.221
Logistic regression test	P= 0.252	P= 0.307	P= 0.730	P= 0.243
Cochran-Armitage test	P= 0.316			
Fisher exact test		P= 0.301	P= 0.753N	P= 0.309
Pancreatic Islets: Adenoma or Carcinoma				
Overall rate	3/50 (6%)	4/49 (8%)	2/50 (4%)	4/50 (8%)
Adjusted rate	18.6%	12.3%	16.1%	27.6%
Terminal rate	1/12 (8%)	0/15 (0%)	1/11 (9%)	2/10 (20%)
First incidence (days)	695	540	720	636
Life table test	P= 0.322	P= 0.544	P= 0.538N	P= 0.358
Logistic regression test	P= 0.388	P= 0.500	P= 0.571N	P= 0.373
Cochran-Armitage test	P= 0.484			
Fisher exact test		P= 0.489	P= 0.500N	P= 0.500

TABLE A3
Statistical Analysis of Primary Neoplasms in Male Rats in the 2-Year Inhalation Study of Isobutyraldehyde (continued)

	Chamber Control	500 ppm	1,000 ppm	2,000 ppm
Pituitary Gland (Pars Distalis): Adenoma				
Overall rate	41/50 (82%)	27/49 (55%)	37/49 (76%)	34/50 (68%)
Adjusted rate	97.5%	78.9%	94.1%	93.1%
Terminal rate	11/12 (92%)	9/15 (60%)	9/11 (82%)	8/10 (80%)
First incidence (days)	465	384	479	468
Life table test	P= 0.232	P= 0.010N	P= 0.492	P= 0.529
Logistic regression test	P= 0.351N	P= 0.002N	P= 0.345N	P= 0.109N
Cochran-Armitage test	P= 0.279N			
Fisher exact test		P= 0.004N	P= 0.294N	P= 0.083N
Preputial Gland: Carcinoma				
Overall rate	2/50 (4%)	2/49 (4%)	4/50 (8%)	3/50 (6%)
Adjusted rate	14.9%	8.6%	16.6%	20.9%
Terminal rate	1/12 (8%)	1/15 (7%)	1/11 (9%)	1/10 (10%)
First incidence (days)	720	384	419	652
Life table test	P= 0.262	P= 0.641N	P= 0.297	P= 0.379
Logistic regression test	P= 0.362	P= 0.687	P= 0.339	P= 0.390
Cochran-Armitage test	P= 0.360			
Fisher exact test		P= 0.684	P= 0.339	P= 0.500
Preputial Gland: Adenoma or Carcinoma				
Overall rate	2/50 (4%)	4/49 (8%)	5/50 (10%)	3/50 (6%)
Adjusted rate	14.9%	19.3%	20.6%	20.9%
Terminal rate	1/12 (8%)	2/15 (13%)	1/11 (9%)	1/10 (10%)
First incidence (days)	720	384	419	652
Life table test	P= 0.335	P= 0.401	P= 0.184	P= 0.379
Logistic regression test	P= 0.458	P= 0.338	P= 0.222	P= 0.390
Cochran-Armitage test	P= 0.467			
Fisher exact test		P= 0.329	P= 0.218	P= 0.500
Skin: Keratoacanthoma				
Overall rate	2/50 (4%)	4/50 (8%)	3/50 (6%)	2/50 (4%)
Adjusted rate	15.4%	21.3%	20.6%	14.3%
Terminal rate	1/12 (8%)	2/15 (13%)	2/11 (18%)	1/10 (10%)
First incidence (days)	729	679	578	652
Life table test	P= 0.546	P= 0.419	P= 0.448	P= 0.606
Logistic regression test	P= 0.556	P= 0.380	P= 0.430	P= 0.598
Cochran-Armitage test	P= 0.479N			
Fisher exact test		P= 0.339	P= 0.500	P= 0.691N
Skin: Squamous Cell Papilloma or Keratoacanthoma				
Overall rate	2/50 (4%)	6/50 (12%)	3/50 (6%)	2/50 (4%)
Adjusted rate	15.4%	30.2%	20.6%	14.3%
Terminal rate	1/12 (8%)	3/15 (20%)	2/11 (18%)	1/10 (10%)
First incidence (days)	729	674	578	652
Life table test	P= 0.532N	P= 0.192	P= 0.448	P= 0.606
Logistic regression test	P= 0.513N	P= 0.155	P= 0.430	P= 0.598
Cochran-Armitage test	P= 0.367N			
Fisher exact test		P= 0.134	P= 0.500	P= 0.691N

TABLE A3
Statistical Analysis of Primary Neoplasms in Male Rats in the 2-Year Inhalation Study of Isobutyraldehyde (continued)

	Chamber Control	500 ppm	1,000 ppm	2,000 ppm
Skin: Squamous Cell Papilloma, Keratoacanthoma, Trichoepithelioma, or Basal Cell Adenoma				
Overall rate	2/50 (4%)	7/50 (14%)	4/50 (8%)	2/50 (4%)
Adjusted rate	15.4%	36.0%	24.8%	14.3%
Terminal rate	1/12 (8%)	4/15 (27%)	2/11 (18%)	1/10 (10%)
First incidence (days)	729	674	578	652
Life table test	P= 0.525N	P= 0.127	P= 0.289	P= 0.606
Logistic regression test	P= 0.499N	P= 0.094	P= 0.267	P= 0.598
Cochran-Armitage test	P= 0.341N			
Fisher exact test		P= 0.080	P= 0.339	P= 0.691N
Skin (Subcutaneous Tissue): Fibroma				
Overall rate	3/50 (6%)	1/50 (2%)	1/50 (2%)	4/50 (8%)
Adjusted rate	19.9%	5.9%	4.0%	26.5%
Terminal rate	2/12 (17%)	0/15 (0%)	0/11 (0%)	1/10 (10%)
First incidence (days)	678	716	636	650
Life table test	P= 0.192	P= 0.255N	P= 0.369N	P= 0.355
Logistic regression test	P= 0.205	P= 0.270N	P= 0.355N	P= 0.369
Cochran-Armitage test	P= 0.302			
Fisher exact test		P= 0.309N	P= 0.309N	P= 0.500
Skin (Subcutaneous Tissue): Fibroma, Fibrosarcoma, or Sarcoma				
Overall rate	3/50 (6%)	2/50 (4%)	2/50 (4%)	4/50 (8%)
Adjusted rate	19.9%	9.1%	6.5%	26.5%
Terminal rate	2/12 (17%)	0/15 (0%)	0/11 (0%)	1/10 (10%)
First incidence (days)	678	664	541	650
Life table test	P= 0.227	P= 0.440N	P= 0.574N	P= 0.355
Logistic regression test	P= 0.280	P= 0.466N	P= 0.533N	P= 0.369
Cochran-Armitage test	P= 0.357			
Fisher exact test		P= 0.500N	P= 0.500N	P= 0.500
Testes: Adenoma				
Overall rate	30/50 (60%)	43/50 (86%)	30/50 (60%)	36/50 (72%)
Adjusted rate	88.9%	100.0%	100.0%	94.0%
Terminal rate	9/12 (75%)	15/15 (100%)	11/11 (100%)	8/10 (80%)
First incidence (days)	421	540	440	441
Life table test	P= 0.064	P= 0.145	P= 0.353	P= 0.060
Logistic regression test	P= 0.219	P= 0.004	P= 0.444	P= 0.108
Cochran-Armitage test	P= 0.388			
Fisher exact test		P= 0.003	P= 0.581N	P= 0.146
Thymus: Benign or Malignant Thymoma				
Overall rate	0/50 (0%)	0/49 (0%)	3/50 (6%)	0/49 (0%)
Adjusted rate	0.0%	0.0%	20.9%	0.0%
Terminal rate	0/12 (0%)	0/15 (0%)	2/11 (18%)	0/10 (0%)
First incidence (days)	—	—	601	—
Life table test	P= 0.478	— ^f	P= 0.099	—
Logistic regression test	P= 0.485	—	P= 0.097	—
Cochran-Armitage test	P= 0.536			
Fisher exact test		—	P= 0.121	—

TABLE A3
Statistical Analysis of Primary Neoplasms in Male Rats in the 2-Year Inhalation Study of Isobutyraldehyde (continued)

	Chamber Control	500 ppm	1,000 ppm	2,000 ppm
Thyroid Gland (C-cell): Adenoma				
Overall rate	1/50 (2%)	2/49 (4%)	4/50 (8%)	2/50 (4%)
Adjusted rate	5.6%	11.3%	22.2%	20.0%
Terminal rate	0/12 (0%)	1/15 (7%)	1/11 (9%)	2/10 (20%)
First incidence (days)	698	692	617	733 (T)
Life table test	P= 0.247	P= 0.532	P= 0.150	P= 0.411
Logistic regression test	P= 0.273	P= 0.526	P= 0.143	P= 0.397
Cochran-Armitage test	P= 0.390			
Fisher exact test		P= 0.492	P= 0.181	P= 0.500
Thyroid Gland (C-cell): Carcinoma				
Overall rate	3/50 (6%)	1/49 (2%)	1/50 (2%)	1/50 (2%)
Adjusted rate	19.0%	3.6%	2.4%	7.1%
Terminal rate	2/12 (17%)	0/15 (0%)	0/11 (0%)	0/10 (0%)
First incidence (days)	608	667	520	680
Life table test	P= 0.331N	P= 0.255N	P= 0.351N	P= 0.396N
Logistic regression test	P= 0.257N	P= 0.291N	P= 0.317N	P= 0.366N
Cochran-Armitage test	P= 0.240N			
Fisher exact test		P= 0.316N	P= 0.309N	P= 0.309N
Thyroid Gland (C-cell): Adenoma or Carcinoma				
Overall rate	4/50 (8%)	3/49 (6%)	5/50 (10%)	3/50 (6%)
Adjusted rate	23.5%	14.5%	24.0%	25.7%
Terminal rate	2/12 (17%)	1/15 (7%)	1/11 (9%)	2/10 (20%)
First incidence (days)	608	667	520	680
Life table test	P= 0.476	P= 0.433N	P= 0.425	P= 0.635N
Logistic regression test	P= 0.564	P= 0.472N	P= 0.448	P= 0.629N
Cochran-Armitage test	P= 0.478N			
Fisher exact test		P= 0.511N	P= 0.500	P= 0.500N
All Organs: Mononuclear Cell Leukemia				
Overall rate	33/50 (66%)	32/50 (64%)	23/50 (46%)	34/50 (68%)
Adjusted rate	84.9%	85.1%	77.5%	91.0%
Terminal rate	7/12 (58%)	10/15 (67%)	6/11 (55%)	7/10 (70%)
First incidence (days)	259	554	468	441
Life table test	P= 0.133	P= 0.309N	P= 0.233N	P= 0.164
Logistic regression test	P= 0.406	P= 0.459N	P= 0.046N	P= 0.428
Cochran-Armitage test	P= 0.520			
Fisher exact test		P= 0.500N	P= 0.035N	P= 0.500
All Organs: Benign Neoplasms				
Overall rate	47/50 (94%)	49/50 (98%)	46/50 (92%)	49/50 (98%)
Adjusted rate	100.0%	100.0%	100.0%	100.0%
Terminal rate	12/12 (100%)	15/15 (100%)	11/11 (100%)	10/10 (100%)
First incidence (days)	421	384	440	441
Life table test	P= 0.060	P= 0.392N	P= 0.318	P= 0.110
Logistic regression test	P= 0.408	P= 0.245	P= 0.543N	P= 0.364
Cochran-Armitage test	P= 0.343			
Fisher exact test		P= 0.309	P= 0.500N	P= 0.309

TABLE A3
Statistical Analysis of Primary Neoplasms in Male Rats in the 2-Year Inhalation Study of Isobutyraldehyde (continued)

	Chamber Control	500 ppm	1,000 ppm	2,000 ppm
All Organs: Malignant Neoplasms				
Overall rate	40/50 (80%)	38/50 (76%)	33/50 (66%)	36/50 (72%)
Adjusted rate	92.5%	89.8%	86.6%	91.3%
Terminal rate	9/12 (75%)	11/15 (73%)	7/11 (64%)	7/10 (70%)
First incidence (days)	259	384	419	441
Life table test	P= 0.284	P= 0.257N	P= 0.432N	P= 0.358
Logistic regression test	P= 0.215N	P= 0.384N	P= 0.091N	P= 0.267N
Cochran-Armitage test	P= 0.186N			
Fisher exact test		P= 0.405N	P= 0.088N	P= 0.241N
All Organs: Benign or Malignant Neoplasms				
Overall rate	50/50 (100%)	49/50 (98%)	49/50 (98%)	50/50 (100%)
Adjusted rate	100.0%	100.0%	100.0%	100.0%
Terminal rate	12/12 (100%)	15/15 (100%)	11/11 (100%)	10/10 (100%)
First incidence (days)	259	384	419	441
Life table test	P= 0.080	P= 0.267N	P= 0.319	P= 0.162
Logistic regression test	P= 0.590N	P= 0.500N	P= 0.450N	—
Cochran-Armitage test	P= 0.595			
Fisher exact test		P= 0.500N	P= 0.500N	P= 1.000N

(T)Terminal sacrifice

^a Number of neoplasm-bearing animals/number of animals examined. Denominator is number of animals examined microscopically for adrenal gland, pancreatic islets, pituitary gland, preputial gland, testes, thymus, and thyroid gland; for other tissues, denominator is number of animals necropsied.

^b Kaplan-Meier estimated neoplasm incidence at the end of the study after adjustment for intercurrent mortality

^c Observed incidence at terminal kill

^d Beneath the chamber control incidence are the P values associated with the trend test. Beneath the exposed group incidence are the P values corresponding to pairwise comparisons between the chamber controls and that exposed group. The life table test regards neoplasms in animals dying prior to terminal kill as being (directly or indirectly) the cause of death. The logistic regression test regards these lesions as nonfatal. The Cochran-Armitage and Fisher exact tests compare directly the overall incidence rates. For all tests, a negative trend or a lower incidence in an exposure group is indicated by **N**.

^e Not applicable; no neoplasms in animal group

^f Value of statistic cannot be computed.

TABLE A4
Historical Incidence of Adenoma of the Nose in Chamber Control Male F344/N Rats^a

Study	Incidence in Controls
Historical Incidence at Battelle Pacific Northwest Laboratories	
CS2 (<i>o</i> -Chlorobenzalmalononitrile)	0/50
Acetonitrile	0/48
2-Chloroacetophenone	0/46
<i>l</i> -Epinephrine Hydrochloride	1/50
Chloroethane	0/50
Hexachlorocyclopentadiene	0/48
Ozone	0/50
Overall Historical Incidence	
Total	1/646 (0.2%)
Standard deviation	0.6%
Range	0%-2%

^a Data as of 12 May 1995

TABLE A5
Summary of the Incidence of Nonneoplastic Lesions in Male Rats in the 2-Year Inhalation Study of Isobutyraldehyde^a

	Chamber Control	500 ppm	1,000 ppm	2,000 ppm
Disposition Summary				
Animals initially in study	50	50	50	50
Early deaths				
Moribund	35	32	34	35
Natural deaths	3	3	5	5
Survivors				
Terminal sacrifice	12	15	11	10
Animals examined microscopically	50	50	50	50
Alimentary System				
Intestine large, colon	(50)	(49)	(49)	(50)
Inflammation, suppurative			1 (2%)	
Parasite metazoan	1 (2%)	2 (4%)	3 (6%)	4 (8%)
Ulcer			1 (2%)	
Intestine large, rectum	(50)	(47)	(49)	(50)
Parasite metazoan	4 (8%)	3 (6%)	3 (6%)	2 (4%)
Intestine large, cecum	(47)	(49)	(48)	(48)
Edema				1 (2%)
Parasite metazoan	2 (4%)	1 (2%)	3 (6%)	8 (17%)
Intestine small, ileum	(48)	(49)	(48)	(47)
Diverticulum			1 (2%)	
Epithelium, hyperplasia			1 (2%)	
Liver	(50)	(49)	(50)	(50)
Angiectasis	2 (4%)	6 (12%)	4 (8%)	
Basophilic focus		2 (4%)	1 (2%)	
Clear cell focus	3 (6%)	2 (4%)		1 (2%)
Eosinophilic focus	1 (2%)			
Hemorrhage				1 (2%)
Hepatodiaphragmatic nodule	5 (10%)	4 (8%)	5 (10%)	5 (10%)
Hyperplasia, reticulum cell				1 (2%)
Inflammation, granulomatous			2 (4%)	
Mixed cell focus			1 (2%)	
Thrombosis			1 (2%)	
Vacuolization cytoplasmic	10 (20%)	6 (12%)	6 (12%)	8 (16%)
Bile duct, hyperplasia	4 (8%)	2 (4%)	3 (6%)	3 (6%)
Hepatocyte, degeneration, cystic	2 (4%)	5 (10%)	5 (10%)	4 (8%)
Hepatocyte, hyperplasia	1 (2%)	2 (4%)	2 (4%)	2 (4%)
Hepatocyte, necrosis	2 (4%)	2 (4%)	4 (8%)	3 (6%)
Serosa, fibrosis				1 (2%)
Mesentery	(11)	(12)	(8)	(10)
Fat, hemorrhage		1 (8%)		
Fat, inflammation, granulomatous	1 (9%)	1 (8%)		1 (10%)
Fat, necrosis	10 (91%)	10 (83%)	7 (88%)	7 (70%)
Oral mucosa		(3)	(2)	(2)
Cyst		1 (33%)		
Hyperplasia				1 (50%)
Gingival, hyperplasia			1 (50%)	
Pharyngeal, hyperplasia		1 (33%)	1 (50%)	
Pancreas	(50)	(48)	(50)	(50)
Atrophy	9 (18%)	8 (17%)	11 (22%)	7 (14%)

^a Number of animals examined microscopically at the site and the number of animals with lesion

TABLE A5
Summary of the Incidence of Nonneoplastic Lesions in Male Rats in the 2-Year Inhalation Study of Isobutyraldehyde
 (continued)

	Chamber Control	500 ppm	1,000 ppm	2,000 ppm
Alimentary System (continued)				
Stomach, forestomach	(50)	(49)	(50)	(50)
Edema	3 (6%)			2 (4%)
Hyperkeratosis			3 (6%)	
Hyperplasia	5 (10%)	9 (18%)	15 (30%)	7 (14%)
Inflammation, suppurative		1 (2%)	2 (4%)	1 (2%)
Necrosis		1 (2%)		
Ulcer	4 (8%)	5 (10%)	9 (18%)	4 (8%)
Stomach, glandular	(50)	(49)	(50)	(50)
Inflammation, suppurative		1 (2%)		
Mineralization				1 (2%)
Necrosis	2 (4%)			1 (2%)
Thrombosis			1 (2%)	
Ulcer		1 (2%)	1 (2%)	
Tooth		(1)	(1)	
Developmental malformation		1 (100%)		
Inflammation, suppurative			1 (100%)	
Cardiovascular System				
Blood vessel	(41)	(48)	(50)	(38)
Mineralization				1 (3%)
Heart	(50)	(49)	(50)	(50)
Cardiomyopathy	6 (12%)	1 (2%)	3 (6%)	8 (16%)
Mineralization				1 (2%)
Atrium, thrombosis	2 (4%)	2 (4%)	4 (8%)	3 (6%)
Endocrine System				
Adrenal cortex	(50)	(49)	(50)	(50)
Hemorrhage	1 (2%)	1 (2%)		
Hyperplasia		1 (2%)		
Vacuolization cytoplasmic	3 (6%)	6 (12%)	6 (12%)	3 (6%)
Adrenal medulla	(49)	(49)	(50)	(50)
Hyperplasia	20 (41%)	16 (33%)	12 (24%)	14 (28%)
Islets, pancreatic	(50)	(49)	(50)	(50)
Hyperplasia	2 (4%)	3 (6%)	1 (2%)	1 (2%)
Parathyroid gland	(48)	(48)	(49)	(48)
Hyperplasia	1 (2%)	1 (2%)		3 (6%)
Pituitary gland	(50)	(49)	(49)	(50)
Cyst	3 (6%)	2 (4%)	2 (4%)	7 (14%)
Hemorrhage	2 (4%)	4 (8%)	3 (6%)	
Pars distalis, hyperplasia	4 (8%)	9 (18%)	5 (10%)	6 (12%)
Pars distalis, hypertrophy		1 (2%)		
Thyroid gland	(50)	(49)	(50)	(50)
C-cell, hyperplasia	3 (6%)	5 (10%)	8 (16%)	5 (10%)
Follicular cell, hyperplasia	1 (2%)	1 (2%)		
General Body System				
None				

TABLE A5
Summary of the Incidence of Nonneoplastic Lesions in Male Rats in the 2-Year Inhalation Study of Isobutyraldehyde
 (continued)

	Chamber Control	500 ppm	1,000 ppm	2,000 ppm
Genital System				
Epididymis	(50)	(49)	(50)	(50)
Inflammation, granulomatous	2 (4%)		1 (2%)	
Inflammation, suppurative	1 (2%)			
Epithelium, hyperplasia			1 (2%)	
Penis			(1)	
Hemorrhage			1 (100%)	
Thrombosis, acute			1 (100%)	
Preputial gland	(50)	(49)	(50)	(50)
Cyst	3 (6%)	10 (20%)	11 (22%)	1 (2%)
Hyperplasia	4 (8%)	1 (2%)	2 (4%)	2 (4%)
Inflammation, chronic	1 (2%)		1 (2%)	
Inflammation, suppurative	9 (18%)	3 (6%)	8 (16%)	10 (20%)
Prostate	(50)	(49)	(50)	(50)
Inflammation, suppurative	4 (8%)	4 (8%)	4 (8%)	2 (4%)
Epithelium, hyperplasia	2 (4%)	3 (6%)	2 (4%)	3 (6%)
Seminal vesicle	(50)	(49)	(50)	(50)
Inflammation, suppurative		1 (2%)		
Epithelium, hyperplasia	1 (2%)	1 (2%)		
Testes	(50)	(50)	(50)	(50)
Necrosis				1 (2%)
Artery, inflammation	3 (6%)		1 (2%)	1 (2%)
Germinal epithelium, atrophy	7 (14%)	6 (12%)	8 (16%)	8 (16%)
Interstitial cell, hyperplasia	7 (14%)	1 (2%)	5 (10%)	8 (16%)
Hematopoietic System				
Bone marrow	(50)	(49)	(50)	(50)
Hyperplasia, reticulum cell			1 (2%)	
Myelofibrosis				2 (4%)
Lymph node	(15)	(10)	(6)	(7)
Iliac, ectasia		1 (10%)		
Lymph node, bronchial	(50)	(46)	(49)	(50)
Fibrosis			1 (2%)	
Lymph node, mandibular	(46)	(46)	(44)	(44)
Fibrosis				1 (2%)
Hyperplasia, lymphoid	1 (2%)	1 (2%)		1 (2%)
Lymph node, mesenteric	(50)	(49)	(50)	(50)
Ectasia				1 (2%)
Fibrosis			1 (2%)	
Hyperplasia, lymphoid	1 (2%)			
Lymph node, mediastinal	(49)	(49)	(50)	(50)
Fibrosis			1 (2%)	2 (4%)
Hemorrhage	1 (2%)	1 (2%)		
Hyperplasia, histiocytic		1 (2%)		
Spleen	(50)	(49)	(50)	(50)
Accessory spleen	1 (2%)	1 (2%)	1 (2%)	
Angiectasis		1 (2%)		
Fibrosis	10 (20%)	18 (37%)	9 (18%)	17 (34%)
Hematopoietic cell proliferation				1 (2%)
Hemorrhage	3 (6%)	1 (2%)	1 (2%)	2 (4%)
Necrosis		1 (2%)	2 (4%)	1 (2%)
Thymus	(50)	(49)	(50)	(49)
Ectopic parathyroid gland			1 (2%)	

TABLE A5
Summary of the Incidence of Nonneoplastic Lesions in Male Rats in the 2-Year Inhalation Study of Isobutyraldehyde
 (continued)

	Chamber Control	500 ppm	1,000 ppm	2,000 ppm
Integumentary System				
Mammary gland	(50)	(49)	(50)	(50)
Galactocele	5 (10%)		1 (2%)	3 (6%)
Epithelium, hyperplasia		1 (2%)	1 (2%)	
Skin	(50)	(50)	(50)	(50)
Acanthosis		1 (2%)		
Hyperkeratosis	2 (4%)	13 (26%)	2 (4%)	
Hyperplasia		5 (10%)		
Inflammation, granulomatous	2 (4%)			4 (8%)
Inflammation, suppurative	3 (6%)			2 (4%)
Ulcer	1 (2%)	1 (2%)	3 (6%)	5 (10%)
Epidermis, cyst	4 (8%)	1 (2%)	1 (2%)	3 (6%)
Sebaceous gland, cyst			1 (2%)	
Sebaceous gland, hyperplasia		1 (2%)		
Subcutaneous tissue, edema			1 (2%)	
Subcutaneous tissue, hemorrhage	1 (2%)			
Subcutaneous tissue, epidermis, cyst			1 (2%)	
Musculoskeletal System				
Bone	(50)	(48)	(50)	(50)
Cranium, fibrosis		1 (2%)		
Cranium, inflammation, granulomatous		2 (4%)		
Nervous System				
Brain	(50)	(50)	(50)	(50)
Gliosis				1 (2%)
Hemorrhage	4 (8%)	9 (18%)	6 (12%)	4 (8%)
Ventricle, hydrocephalus	3 (6%)	1 (2%)	8 (16%)	5 (10%)
Spinal cord		(1)	(1)	(1)
Hemorrhage				1 (100%)
Respiratory System				
Larynx	(50)	(49)	(49)	(50)
Foreign body	3 (6%)	4 (8%)	3 (6%)	5 (10%)
Inflammation, suppurative		1 (2%)		2 (4%)
Epiglottis, metaplasia, squamous				1 (2%)
Epithelium, hyperplasia	1 (2%)	1 (2%)	1 (2%)	1 (2%)
Epithelium, metaplasia, squamous	1 (2%)	3 (6%)	1 (2%)	4 (8%)
Glands, inflammation, suppurative	4 (8%)	6 (12%)	6 (12%)	3 (6%)
Lung	(50)	(49)	(50)	(50)
Hemorrhage	7 (14%)	3 (6%)	8 (16%)	6 (12%)
Inflammation, granulomatous			1 (2%)	
Alveolar epithelium, fibrosis		5 (10%)		
Alveolar epithelium, foreign body	1 (2%)		1 (2%)	
Alveolar epithelium, hyperplasia	5 (10%)	9 (18%)	4 (8%)	5 (10%)
Alveolar epithelium, infiltration cellular, histiocyte	2 (4%)	10 (20%)	8 (16%)	6 (12%)
Alveolar epithelium, pigmentation			1 (2%)	
Bronchiole, bronchus, interstitium, fibrosis		1 (2%)		
Interstitium, mineralization		1 (2%)		

TABLE A5
Summary of the Incidence of Nonneoplastic Lesions in Male Rats in the 2-Year Inhalation Study of Isobutyraldehyde
 (continued)

	Chamber Control	500 ppm	1,000 ppm	2,000 ppm
Respiratory System (continued)				
Nose	(50)	(49)	(49)	(50)
Cyst	5 (10%)	3 (6%)	7 (14%)	7 (14%)
Foreign body	5 (10%)	5 (10%)	4 (8%)	7 (14%)
Inflammation, suppurative	5 (10%)	3 (6%)	6 (12%)	15 (30%)
Nasopharyngeal duct, hyperplasia			1 (2%)	
Nasopharyngeal duct, inflammation, suppurative				1 (2%)
Nasopharyngeal duct, metaplasia, squamous				2 (4%)
Olfactory epithelium, degeneration			3 (6%)	44 (88%)
Respiratory epithelium, hyperplasia	2 (4%)		3 (6%)	5 (10%)
Respiratory epithelium, metaplasia, squamous	1 (2%)	1 (2%)	10 (20%)	44 (88%)
Vomeronasal organ, dilatation				1 (2%)
Special Senses System				
Eye	(4)	(1)	(5)	(3)
Cataract	3 (75%)		2 (40%)	3 (100%)
Cornea, mineralization	1 (25%)			1 (33%)
Cornea, lens, mineralization				1 (33%)
Lens, cataract		1 (100%)	1 (20%)	
Lens, mineralization	1 (25%)			
Harderian gland			(1)	
Hyperplasia			1 (100%)	
Urinary System				
Kidney	(50)	(49)	(50)	(50)
Nephropathy, chronic	47 (94%)	48 (98%)	48 (96%)	49 (98%)
Artery, inflammation			1 (2%)	
Artery, necrosis, fibrinoid			1 (2%)	
Cortex, cyst			1 (2%)	
Cortex, necrosis		1 (2%)		2 (4%)
Pelvis, transitional epithelium, hyperplasia	1 (2%)			
Renal tubule, hyperplasia		1 (2%)		2 (4%)
Renal tubule, hyperplasia, atypical			1 (2%)	
Renal tubule, mineralization				1 (2%)
Urinary bladder	(50)	(48)	(50)	(50)
Calculus, microscopic observation only	1 (2%)	1 (2%)	1 (2%)	
Hemorrhage			2 (4%)	1 (2%)
Inflammation, suppurative	1 (2%)	1 (2%)		
Ulcer		1 (2%)		
Transitional epithelium, hyperplasia	4 (8%)	2 (4%)		

APPENDIX B
SUMMARY OF LESIONS IN FEMALE RATS
IN THE 2-YEAR INHALATION STUDY
OF ISOBUTYRALDEHYDE

TABLE B1	Summary of the Incidence of Neoplasms in Female Rats in the 2-Year Inhalation Study of Isobutylaldehyde	90
TABLE B2	Individual Animal Tumor Pathology of Female Rats in the 2-Year Inhalation Study of Isobutylaldehyde	94
TABLE B3	Statistical Analysis of Primary Neoplasms in Female Rats in the 2-Year Inhalation Study of Isobutylaldehyde	110
TABLE B4a	Historical Incidence of Fibrosarcoma of the Nose in Chamber Control Female F344/N Rats	114
TABLE B4b	Historical Incidence of Mononuclear Cell Leukemia in Chamber Control Female F344/N Rats	114
TABLE B5	Summary of the Incidence of Nonneoplastic Lesions in Female Rats in the 2-Year Inhalation Study of Isobutylaldehyde	115

TABLE B1
Summary of the Incidence of Neoplasms in Female Rats in the 2-Year Inhalation Study of Isobutyraldehyde^a

	Chamber Control	500 ppm	1,000 ppm	2,000 ppm
Disposition Summary				
Animals initially in study	50	50	50	50
Early deaths				
Accidental death		1		
Moribund	17	22	22	13
Natural deaths	6	3	4	5
Survivors				
Died last week of study				1
Terminal sacrifice	27	24	24	31
Animals examined microscopically	50	50	50	50
Alimentary System				
Esophagus	(49)	(50)	(50)	(50)
Intestine small, duodenum	(48)	(47)	(49)	(47)
Intestine small, jejunum	(47)	(47)	(49)	(45)
Carcinoma	1 (2%)			
Intestine small, ileum	(47)	(47)	(49)	(45)
Liver	(49)	(50)	(50)	(50)
Fibrous histiocytoma, metastatic, skin		1 (2%)		
Hepatocellular adenoma		1 (2%)	2 (4%)	
Mesentery	(7)	(7)	(8)	(4)
Fibrosarcoma	1 (14%)			
Sarcoma		1 (14%)		
Oral mucosa	(4)		(2)	(3)
Pharyngeal, squamous cell carcinoma				1 (33%)
Pancreas	(49)	(49)	(49)	(50)
Stomach, forestomach	(49)	(49)	(50)	(50)
Stomach, glandular	(48)	(49)	(50)	(50)
Tongue	(1)		(1)	(2)
Squamous cell papilloma	1 (100%)		1 (100%)	1 (50%)
Cardiovascular System				
Heart	(50)	(50)	(50)	(50)
Endocrine System				
Adrenal cortex	(49)	(49)	(50)	(50)
Adenoma	1 (2%)		1 (2%)	2 (4%)
Fibrous histiocytoma, metastatic, skin		1 (2%)		
Adrenal medulla	(49)	(49)	(47)	(49)
Pheochromocytoma malignant				1 (2%)
Pheochromocytoma benign	1 (2%)		2 (4%)	
Islets, pancreatic	(50)	(48)	(49)	(50)
Adenoma	2 (4%)	1 (2%)		1 (2%)
Carcinoma				1 (2%)
Pituitary gland	(48)	(50)	(49)	(50)
Carcinoma		1 (2%)		
Pars distalis, adenoma	34 (71%)	28 (56%)	33 (67%)	29 (58%)

TABLE B1
Summary of the Incidence of Neoplasms in Female Rats in the 2-Year Inhalation Study of Isobutyraldehyde (continued)

	Chamber Control	500 ppm	1,000 ppm	2,000 ppm
Endocrine System (continued)				
Thyroid gland	(49)	(49)	(50)	(50)
C-cell, adenoma	1 (2%)	4 (8%)	2 (4%)	3 (6%)
C-cell, carcinoma	1 (2%)			
Follicular cell, adenoma			1 (2%)	
Follicular cell, carcinoma	1 (2%)			
General Body System				
None				
Genital System				
Clitoral gland	(48)	(50)	(50)	(48)
Adenoma	1 (2%)	2 (4%)		1 (2%)
Carcinoma	4 (8%)	5 (10%)	4 (8%)	3 (6%)
Ovary	(49)	(50)	(50)	(50)
Granulosa-theca tumor malignant		1 (2%)	1 (2%)	
Bilateral, fibrous histiocytoma, metastatic, skin		1 (2%)		
Uterus	(48)	(50)	(50)	(50)
Leiomyoma				1 (2%)
Leiomyosarcoma		1 (2%)		
Polyp stromal	2 (4%)	5 (10%)	1 (2%)	6 (12%)
Sarcoma stromal		2 (4%)		1 (2%)
Vagina				(1)
Polyp				1 (100%)
Hematopoietic System				
Bone marrow	(49)	(49)	(50)	(50)
Fibrous histiocytoma, metastatic, skin		1 (2%)		
Lymph node	(4)	(4)	(4)	(5)
Fibrous histiocytoma, metastatic, skin		1 (25%)		
Lymph node, bronchial	(49)	(50)	(50)	(50)
Fibrous histiocytoma, metastatic, skin		1 (2%)		
Lymph node, mandibular	(45)	(50)	(46)	(46)
Fibrous histiocytoma, metastatic, skin		1 (2%)		
Lymph node, mesenteric	(49)	(50)	(50)	(50)
Lymph node, mediastinal	(48)	(49)	(50)	(50)
Fibrous histiocytoma, metastatic, skin		1 (2%)		
Spleen	(49)	(49)	(49)	(50)
Hemangiosarcoma	1 (2%)			
Integumentary System				
Mammary gland	(50)	(50)	(50)	(50)
Carcinoma	1 (2%)	1 (2%)	5 (10%)	1 (2%)
Carcinoma, multiple			1 (2%)	
Fibroadenoma	23 (46%)	17 (34%)	19 (38%)	17 (34%)
Fibroadenoma, multiple	4 (8%)	4 (8%)	5 (10%)	7 (14%)

TABLE B1
Summary of the Incidence of Neoplasms in Female Rats in the 2-Year Inhalation Study of Isobutyraldehyde (continued)

	Chamber Control	500 ppm	1,000 ppm	2,000 ppm
Integumentary System (continued)				
Skin	(49)	(50)	(50)	(50)
Keratoacanthoma	1 (2%)			1 (2%)
Lipoma			1 (2%)	
Trichoepithelioma				1 (2%)
Pinna, schwannoma benign		1 (2%)		
Sebaceous gland, adenoma				2 (4%)
Sebaceous gland, carcinoma	1 (2%)			
Subcutaneous tissue, fibroma			1 (2%)	2 (4%)
Subcutaneous tissue, fibrous histiocytoma		1 (2%)		
Subcutaneous tissue, lipoma				1 (2%)
Subcutaneous tissue, osteosarcoma			1 (2%)	
Musculoskeletal System				
Bone	(49)	(50)	(50)	(50)
Rib, osteosarcoma		1 (2%)		
Vertebra, chordoma			1 (2%)	
Nervous System				
Brain	(49)	(49)	(50)	(50)
Astrocytoma malignant				1 (2%)
Carcinoma, metastatic, pituitary gland		1 (2%)		
Granular cell tumor benign	1 (2%)			
Respiratory System				
Larynx	(49)	(50)	(48)	(50)
Lung	(49)	(50)	(50)	(50)
Alveolar/bronchiolar adenoma	1 (2%)			3 (6%)
Alveolar/bronchiolar carcinoma	1 (2%)			
Chordoma, metastatic, tissue NOS			1 (2%)	1 (2%)
Fibrous histiocytoma, metastatic, skin		1 (2%)		
Nose	(49)	(50)	(49)	(50)
Sarcoma		1 (2%)		
Pleura	(1)	(1)		
Osteosarcoma, metastatic, bone		1 (100%)		
Special Senses System				
None				
Urinary System				
Kidney	(49)	(49)	(50)	(50)
Renal tubule, adenoma		1 (2%)		
Urinary bladder	(49)	(49)	(50)	(50)

TABLE B1
Summary of the Incidence of Neoplasms in Female Rats in the 2-Year Inhalation Study of Isobutyraldehyde (continued)

	Chamber Control	500 ppm	1,000 ppm	2,000 ppm
Systemic Lesions				
Multiple organs ^b	(50)	(50)	(50)	(50)
Leukemia mononuclear	12 (24%)	19 (38%)	18 (36%)	25 (50%)
Lymphoma malignant			2 (4%)	
Neoplasm Summary				
Total animals with primary neoplasms ^c	48	49	50	49
Total primary neoplasms	97	98	102	113
Total animals with benign neoplasms	44	37	44	41
Total benign neoplasms	73	64	69	79
Total animals with malignant neoplasms	21	30	25	30
Total malignant neoplasms	24	34	33	34
Total animals with metastatic neoplasms		3	1	1
Total metastatic neoplasms		11	1	1

^a Number of animals examined microscopically at the site and the number of animals with neoplasm

^b Number of animals with any tissue examined microscopically

^c Primary neoplasms: all neoplasms except metastatic neoplasms

TABLE B2
Individual Animal Tumor Pathology of Female Rats in the 2-Year Inhalation Study of Isobutyraldehyde:
Chamber Control

Number of Days on Study	0	4	4	4	4	4	5	5	5	5	5	6	6	6	6	6	6	6	6	6	6	7	7	7	7		
	5	0	2	4	4	9	4	4	6	8	8	1	1	2	2	7	7	8	9	9	9	2	2	3	3		
	6	0	8	7	8	6	7	7	1	0	0	6	7	3	5	8	9	7	0	2	5	0	5	4	4		
Carcass ID Number	1	1	1	1	1	1	1	1	1	1	1	1	1	1	1	1	1	1	1	1	1	1	1	1	1		
	4	1	2	2	2	1	0	3	4	2	4	4	0	1	4	3	1	2	1	4	2	1	4	0	0		
	1	5	6	0	5	1	9	7	6	2	3	9	2	4	4	5	6	8	2	2	3	0	8	6	7		
Alimentary System																											
Esophagus	+	+	+	+	+	+	+	+	+	+	+	+	+	+	+	+	+	+	+	A	+	+	+	+	+	+	
Intestine large, colon	+	+	A	+	+	+	+	+	+	+	+	+	+	+	+	+	+	+	+	A	+	+	+	+	+	+	
Intestine large, rectum	+	+	A	+	+	+	+	+	+	+	+	+	+	+	+	+	+	+	+	A	+	+	+	+	+	+	
Intestine large, cecum	+	+	A	+	+	+	+	+	+	+	+	+	+	+	+	+	+	+	+	A	+	+	+	+	+	+	
Intestine small, duodenum	+	+	A	+	+	+	+	+	+	+	+	+	+	+	+	+	+	+	+	A	+	+	+	+	+	+	
Intestine small, jejunum	+	+	A	+	A	+	+	+	+	+	+	+	+	+	+	+	+	+	+	A	+	+	+	+	+	+	
Carcinoma																										X	
Intestine small, ileum	+	+	A	+	A	+	+	+	+	+	+	+	+	+	+	+	+	+	+	A	+	+	+	+	+	+	
Liver	+	+	+	+	+	+	+	+	+	+	+	+	+	+	+	+	+	+	+	A	+	+	+	+	+	+	
Mesentery								+	+																		
Fibrosarcoma																											X
Oral mucosa	+																										
Pancreas	+	+	+	+	+	+	+	+	+	+	+	+	+	+	+	+	+	+	+	A	+	+	+	+	+	+	
Salivary glands	+	+	+	+	+	+	+	+	+	+	+	+	+	+	+	+	+	+	+	A	+	+	+	+	+	+	
Stomach, forestomach	+	+	+	+	+	+	+	+	+	+	+	+	+	+	+	+	+	+	+	A	+	+	+	+	+	+	
Stomach, glandular	+	+	A	+	+	+	+	+	+	+	+	+	+	+	+	+	+	+	+	A	+	+	+	+	+	+	
Tongue																										+	
Squamous cell papilloma																											X
Tooth	+																										
Cardiovascular System																											
Blood vessel	+	+	+	+	+	+	+	+	+	+	+	+	+	+	+	+	+	+	+	A	+	+	+	+	+	+	
Heart	+	+	+	+	+	+	+	+	+	+	+	+	+	+	+	+	+	+	+	+	+	+	+	+	+	+	
Endocrine System																											
Adrenal cortex	+	+	+	+	+	+	+	+	+	+	+	+	+	+	+	+	+	+	+	A	+	+	+	+	+	+	
Adenoma																											
Adrenal medulla	+	+	+	+	+	+	+	+	+	+	+	+	+	+	+	+	+	+	+	A	+	+	+	+	+	+	
Pheochromocytoma benign																											
Islets, pancreatic	+	+	+	+	+	+	+	+	+	+	+	+	+	+	+	+	+	+	+	+	+	+	+	+	+	+	
Adenoma																										X	
Parathyroid gland	+	+	+	+	M	M	+	+	+	+	+	+	+	+	+	+	+	+	+	A	+	+	+	+	+	+	
Pituitary gland	M	+	+	+	+	+	+	+	+	+	+	+	+	+	+	+	+	+	+	A	+	+	+	+	+	+	
Pars distalis, adenoma			X		X	X				X	X	X	X	X	X	X	X	X	X	X	X	X	X	X	X	X	
Thyroid gland	+	+	+	+	+	+	+	+	+	+	+	+	+	+	+	+	+	+	+	A	+	+	+	+	+	+	
C-cell, adenoma																											
C-cell, carcinoma																											
Follicular cell, carcinoma																											
General Body System																											
Peritoneum																											
Genital System																											
Clitoral gland	+	+	+	+	+	+	M	+	+	+	+	+	+	+	+	+	+	+	+	A	+	+	+	+	+	+	
Adenoma																											
Carcinoma																										X	
Ovary	+	+	+	+	+	+	+	+	+	+	+	+	+	+	+	+	+	+	+	A	+	+	+	+	+	+	
Uterus	+	+	A	+	+	+	+	+	+	+	+	+	+	+	+	+	+	+	+	A	+	+	+	+	+	+	
Polyp stromal																										X	

+: Tissue examined microscopically
A: Autolysis precludes examination

M: Missing tissue
I: Insufficient tissue

X: Lesion present
Blank: Not examined

TABLE B2
Individual Animal Tumor Pathology of Female Rats in the 2-Year Inhalation Study of Isobutyraldehyde:
Chamber Control (continued)

Number of Days on Study	0	4	4	4	4	4	5	5	5	5	5	6	6	6	6	6	6	6	6	6	6	7	7	7	7		
	5	0	2	4	4	9	4	4	6	8	8	1	1	2	2	7	7	8	9	9	9	2	2	3	3		
	6	0	8	7	8	6	7	7	1	0	0	6	7	3	5	8	9	7	0	2	5	0	5	4	4		
Carcass ID Number	1	1	1	1	1	1	1	1	1	1	1	1	1	1	1	1	1	1	1	1	1	1	1	1	1		
	4	1	2	2	2	1	0	3	4	2	4	4	0	1	4	3	1	2	1	4	2	1	4	0	0		
	1	5	6	0	5	1	9	7	6	2	3	9	2	4	4	5	6	8	2	2	3	0	8	6	7		
Hematopoietic System																											
Bone marrow	+	+	+	+	+	+	+	+	+	+	+	+	+	+	+	+	+	+	+	+	A	+	+	+	+	+	+
Lymph node					+		+		+			+															
Lymph node, bronchial	+	+	+	+	+	+	+	+	+	+	+	+	+	+	+	+	+	+	+	+	A	+	+	+	+	+	+
Lymph node, mandibular	+	+	+	+	+	+	+	+	+	+	+	+	+	M	+	+	+	+	+	+	A	+	+	+	+	+	+
Lymph node, mesenteric	+	+	+	+	+	+	+	+	+	+	+	+	+	+	+	+	+	+	+	+	A	+	+	+	+	+	+
Lymph node, mediastinal	+	+	+	+	+	+	+	+	+	+	+	+	+	+	+	+	+	+	+	+	A	+	+	+	+	+	+
Spleen	+	+	+	+	+	+	+	+	+	+	+	+	+	+	+	+	+	+	+	+	A	+	+	+	+	+	+
Hemangiosarcoma																											
Thymus	+	+	+	+	+	+	+	+	+	+	+	+	+	+	+	+	+	+	+	+	A	+	+	+	+	+	M
Integumentary System																											
Mammary gland	+	+	+	+	+	+	+	+	+	+	+	+	+	+	+	+	+	+	+	+	+	+	+	+	+	+	+
Carcinoma																											
Fibroadenoma							X		X		X		X		X	X	X					X	X	X	X		
Fibroadenoma, multiple																							X				
Skin	+	+	+	+	+	+	+	+	+	+	+	+	+	+	+	+	+	+	+	+	A	+	+	+	+	+	+
Keratoacanthoma																											
Sebaceous gland, carcinoma									X																		
Musculoskeletal System																											
Bone	+	+	+	+	+	+	+	+	+	+	+	+	+	+	+	+	+	+	+	+	A	+	+	+	+	+	+
Nervous System																											
Brain	+	+	+	+	+	+	+	+	+	+	+	+	+	+	+	+	+	+	+	+	A	+	+	+	+	+	+
Granular cell tumor benign							X																				
Peripheral nerve																											
Respiratory System																											
Larynx	+	+	+	+	+	+	+	+	+	+	+	+	+	+	+	+	+	+	+	+	A	+	+	+	+	+	+
Lung	+	+	+	+	+	+	+	+	+	+	+	+	+	+	+	+	+	+	+	+	A	+	+	+	+	+	+
Alveolar/bronchiolar adenoma																											
Alveolar/bronchiolar carcinoma																											
Nose	+	+	+	+	+	+	+	+	+	+	+	+	+	+	+	+	+	+	+	+	A	+	+	+	+	+	+
Pleura																											
Trachea	+	+	+	+	+	+	+	+	+	+	+	+	+	+	+	+	+	+	+	+	A	+	+	+	+	+	+
Special Senses System																											
Eye																										+	+
Urinary System																											
Kidney	+	+	+	+	+	+	+	+	+	+	+	+	+	+	+	+	+	+	+	+	A	+	+	+	+	+	+
Urinary bladder	+	+	+	+	+	+	+	+	+	+	+	+	+	+	+	+	+	+	+	+	A	+	+	+	+	+	+
Systemic Lesions																											
Multiple organs	+	+	+	+	+	+	+	+	+	+	+	+	+	+	+	+	+	+	+	+	+	+	+	+	+	+	+
Leukemia mononuclear			X	X		X	X	X	X	X	X	X	X		X							X		X	X		

TABLE B2
Individual Animal Tumor Pathology of Female Rats in the 2-Year Inhalation Study of Isobutyraldehyde: 500 ppm
 (continued)

Number of Days on Study	0	5	5	5	5	5	5	5	6	6	6	6	6	6	6	6	6	6	6	6	6	7	7	7	7		
	7	1	2	4	5	5	7	9	0	2	3	3	4	4	6	7	7	8	8	9	9	0	0	0	0		
	1	1	4	4	1	2	5	1	8	4	6	6	0	2	3	8	8	1	7	2	5	1	1	5	6		
Carcass ID Number	3	3	3	3	3	3	3	3	3	3	3	3	3	3	3	3	3	3	3	3	3	3	3	3	3		
	3	0	0	5	4	2	4	0	4	4	1	4	2	2	0	1	4	1	2	1	2	1	2	1	4		
	2	6	7	0	5	2	1	4	8	3	2	4	1	6	9	9	2	3	4	1	7	7	5	0	7		
Hematopoietic System																											
Bone marrow	+	+	+	+	+	+	+	+	A	+	+	+	+	+	+	+	+	+	+	+	+	+	+	+	+		
Fibrous histiocytoma, metastatic, skin		X																									
Lymph node	+									+										+							
Fibrous histiocytoma, metastatic, skin		X																									
Lymph node, bronchial	+	+	+	+	+	+	+	+	+	+	+	+	+	+	+	+	+	+	+	+	+	+	+	+	+		
Fibrous histiocytoma, metastatic, skin		X																									
Lymph node, mandibular	+	+	+	+	+	+	+	+	+	+	+	+	+	+	+	+	+	+	+	+	+	+	+	+	+		
Fibrous histiocytoma, metastatic, skin		X																									
Lymph node, mesenteric	+	+	+	+	+	+	+	+	+	+	+	+	+	+	+	+	+	+	+	+	+	+	+	+	+		
Lymph node, mediastinal	+	+	+	+	+	+	+	+	+	+	+	+	+	+	+	+	+	+	+	+	+	+	+	+	+		
Fibrous histiocytoma, metastatic, skin		X																									
Spleen	+	+	+	+	+	+	+	+	A	+	+	+	+	+	+	+	+	+	+	+	+	+	+	+	+		
Thymus	+	+	+	+	+	+	+	+	+	+	+	+	+	+	+	+	+	+	+	+	+	+	+	+	+		
Integumentary System																											
Mammary gland	+	+	+	+	+	+	+	+	+	+	+	+	+	+	+	+	+	+	+	+	+	+	+	+	+		
Carcinoma																									X		
Fibroadenoma		X		X							X							X					X				
Fibroadenoma, multiple			X																								
Skin	+	+	+	+	+	+	+	+	+	+	+	+	+	+	+	+	+	+	+	+	+	+	+	+	+		
Pinna, schwannoma benign																											
Subcutaneous tissue, fibrous histiocytoma		X																									
Musculoskeletal System																											
Bone	+	+	+	+	+	+	+	+	+	+	+	+	+	+	+	+	+	+	+	+	+	+	+	+	+		
Rib, osteosarcoma																									X		
Nervous System																											
Brain	+	+	+	+	+	+	+	+	A	+	+	+	+	+	+	+	+	+	+	+	+	+	+	+	+		
Carcinoma, metastatic, pituitary gland																									X		
Respiratory System																											
Larynx	+	+	+	+	+	+	+	+	+	+	+	+	+	+	+	+	+	+	+	+	+	+	+	+	+		
Lung	+	+	+	+	+	+	+	+	+	+	+	+	+	+	+	+	+	+	+	+	+	+	+	+	+		
Fibrous histiocytoma, metastatic, skin		X																									
Nose	+	+	+	+	+	+	+	+	+	+	+	+	+	+	+	+	+	+	+	+	+	+	+	+	+		
Sarcoma																									X		
Pleura																									+		
Osteosarcoma, metastatic, bone																									X		
Trachea	+	+	+	+	+	+	+	+	+	+	+	+	+	+	+	+	+	+	+	+	+	+	+	+	+		
Special Senses System																											
Eye																									+	+	
Urinary System																											
Kidney	+	+	+	+	+	+	+	+	A	+	+	+	+	+	+	+	+	+	+	+	+	+	+	+	+		
Renal tubule, adenoma																											
Urinary bladder	+	+	+	+	+	+	+	+	A	+	+	+	+	+	+	+	+	+	+	+	+	+	+	+	+		
Systemic Lesions																											
Multiple organs	+	+	+	+	+	+	+	+	+	+	+	+	+	+	+	+	+	+	+	+	+	+	+	+	+		
Leukemia mononuclear										X	X	X		X		X		X	X		X	X					

TABLE B3
Statistical Analysis of Primary Neoplasms in Female Rats in the 2-Year Inhalation Study of Isobutyraldehyde

	Chamber Control	500 ppm	1,000 ppm	2,000 ppm
Clitoral Gland: Carcinoma				
Overall rate ^a	4/48 (8%)	5/50 (10%)	4/50 (8%)	3/48 (6%)
Adjusted rate ^b	13.9%	17.1%	16.7%	10.0%
Terminal rate ^c	3/27 (11%)	3/24 (13%)	4/24 (17%)	3/30 (10%)
First incidence (days)	690	544	734 (T)	734 (T)
Life table test ^d	P= 0.297N	P= 0.454	P= 0.592	P= 0.448N
Logistic regression test ^d	P= 0.324N	P= 0.535	P= 0.638N	P= 0.470N
Cochran-Armitage test ^d	P= 0.366N			
Fisher exact test ^d		P= 0.526	P= 0.619N	P= 0.500N
Clitoral Gland: Adenoma or Carcinoma				
Overall rate	5/48 (10%)	7/50 (14%)	4/50 (8%)	4/48 (8%)
Adjusted rate	17.5%	24.0%	16.7%	13.3%
Terminal rate	4/27 (15%)	4/24 (17%)	4/24 (17%)	4/30 (13%)
First incidence (days)	690	544	734 (T)	734 (T)
Life table test	P= 0.245N	P= 0.326	P= 0.562N	P= 0.439N
Logistic regression test	P= 0.274N	P= 0.413	P= 0.495N	P= 0.467N
Cochran-Armitage test	P= 0.320N			
Fisher exact test		P= 0.409	P= 0.474N	P= 0.500N
Lung: Alveolar/bronchiolar Adenoma				
Overall rate	1/49 (2%)	0/50 (0%)	0/50 (0%)	3/50 (6%)
Adjusted rate	3.7%	0.0%	0.0%	8.3%
Terminal rate	1/27 (4%)	0/24 (0%)	0/24 (0%)	1/32 (3%)
First incidence (days)	734 (T)	— ^e	—	646
Life table test	P= 0.112	P= 0.523N	P= 0.523N	P= 0.353
Logistic regression test	P= 0.094	P= 0.523N	P= 0.523N	P= 0.333
Cochran-Armitage test	P= 0.088			
Fisher exact test		P= 0.495N	P= 0.495N	P= 0.316
Lung: Alveolar/bronchiolar Adenoma or Carcinoma				
Overall rate	2/49 (4%)	0/50 (0%)	0/50 (0%)	3/50 (6%)
Adjusted rate	7.4%	0.0%	0.0%	8.3%
Terminal rate	2/27 (7%)	0/24 (0%)	0/24 (0%)	1/32 (3%)
First incidence (days)	734 (T)	—	—	646
Life table test	P= 0.298	P= 0.264N	P= 0.264N	P= 0.560
Logistic regression test	P= 0.270	P= 0.264N	P= 0.264N	P= 0.542
Cochran-Armitage test	P= 0.249			
Fisher exact test		P= 0.242N	P= 0.242N	P= 0.510
Mammary Gland: Fibroadenoma				
Overall rate	27/50 (54%)	21/50 (42%)	24/50 (48%)	24/50 (48%)
Adjusted rate	72.7%	68.0%	62.7%	66.5%
Terminal rate	17/27 (63%)	15/24 (63%)	11/24 (46%)	20/32 (63%)
First incidence (days)	547	511	489	646
Life table test	P= 0.168N	P= 0.275N	P= 0.428N	P= 0.143N
Logistic regression test	P= 0.275N	P= 0.109N	P= 0.210N	P= 0.170N
Cochran-Armitage test	P= 0.424N			
Fisher exact test		P= 0.158N	P= 0.345N	P= 0.345N

TABLE B3
Statistical Analysis of Primary Neoplasms in Female Rats in the 2-Year Inhalation Study of Isobutyraldehyde (continued)

	Chamber Control	500 ppm	1,000 ppm	2,000 ppm
Mammary Gland: Carcinoma				
Overall rate	1/50 (2%)	1/50 (2%)	6/50 (12%)	1/50 (2%)
Adjusted rate	3.7%	3.8%	19.7%	3.1%
Terminal rate	1/27 (4%)	0/24 (0%)	2/24 (8%)	1/32 (3%)
First incidence (days)	734 (T)	706	664	734 (T)
Life table test	P= 0.558	P= 0.735	P= 0.059	P= 0.724N
Logistic regression test	P= 0.521	P= 0.762	P= 0.071	P= 0.724N
Cochran-Armitage test	P= 0.477			
Fisher exact test		P= 0.753N	P= 0.056	P= 0.753N
Mammary Gland: Fibroadenoma or Carcinoma				
Overall rate	27/50 (54%)	22/50 (44%)	29/50 (58%)	24/50 (48%)
Adjusted rate	72.7%	69.2%	71.3%	66.5%
Terminal rate	17/27 (63%)	15/24 (63%)	13/24 (54%)	20/32 (63%)
First incidence (days)	547	511	489	646
Life table test	P= 0.174N	P= 0.348N	P= 0.379	P= 0.143N
Logistic regression test	P= 0.282N	P= 0.151N	P= 0.570N	P= 0.170N
Cochran-Armitage test	P= 0.443N			
Fisher exact test		P= 0.212N	P= 0.420	P= 0.345N
Pituitary Gland (Pars Distalis): Adenoma				
Overall rate	34/48 (71%)	28/50 (56%)	33/49 (67%)	29/50 (58%)
Adjusted rate	80.5%	73.9%	83.8%	72.2%
Terminal rate	19/27 (70%)	15/24 (63%)	18/24 (75%)	21/32 (66%)
First incidence (days)	400	551	487	511
Life table test	P= 0.088N	P= 0.295N	P= 0.554N	P= 0.080N
Logistic regression test	P= 0.145N	P= 0.089N	P= 0.355N	P= 0.087N
Cochran-Armitage test	P= 0.211N			
Fisher exact test		P= 0.094N	P= 0.440N	P= 0.132N
Pituitary Gland (Pars Distalis or Unspecified Site): Adenoma or Carcinoma				
Overall rate	34/48 (71%)	29/50 (58%)	33/49 (67%)	29/50 (58%)
Adjusted rate	80.5%	74.7%	83.8%	72.2%
Terminal rate	19/27 (70%)	15/24 (63%)	18/24 (75%)	21/32 (66%)
First incidence (days)	400	551	487	511
Life table test	P= 0.080N	P= 0.354N	P= 0.554N	P= 0.080N
Logistic regression test	P= 0.127N	P= 0.125N	P= 0.355N	P= 0.087N
Cochran-Armitage test	P= 0.189N			
Fisher exact test		P= 0.132N	P= 0.440N	P= 0.132N
Thyroid Gland (C-cell): Adenoma				
Overall rate	1/49 (2%)	4/49 (8%)	2/50 (4%)	3/50 (6%)
Adjusted rate	3.7%	14.6%	8.3%	9.4%
Terminal rate	1/27 (4%)	3/24 (13%)	2/24 (8%)	3/32 (9%)
First incidence (days)	734 (T)	624	734 (T)	734 (T)
Life table test	P= 0.472	P= 0.159	P= 0.459	P= 0.367
Logistic regression test	P= 0.430	P= 0.186	P= 0.459	P= 0.367
Cochran-Armitage test	P= 0.382			
Fisher exact test		P= 0.181	P= 0.508	P= 0.316

TABLE B3
Statistical Analysis of Primary Neoplasms in Female Rats in the 2-Year Inhalation Study of Isobutyraldehyde (continued)

	Chamber Control	500 ppm	1,000 ppm	2,000 ppm
Thyroid Gland (C-cell): Adenoma or Carcinoma				
Overall rate	2/49 (4%)	4/49 (8%)	2/50 (4%)	3/50 (6%)
Adjusted rate	7.4%	14.6%	8.3%	9.4%
Terminal rate	2/27 (7%)	3/24 (13%)	2/24 (8%)	3/32 (9%)
First incidence (days)	734 (T)	624	734 (T)	734 (T)
Life table test	P= 0.537N	P= 0.301	P= 0.654	P= 0.578
Logistic regression test	P= 0.581N	P= 0.344	P= 0.654	P= 0.578
Cochran-Armitage test	P= 0.532			
Fisher exact test		P= 0.339	P= 0.684N	P= 0.510
Uterus: Stromal Polyp				
Overall rate	2/50 (4%)	5/50 (10%)	1/50 (2%)	6/50 (12%)
Adjusted rate	6.5%	18.6%	4.2%	16.3%
Terminal rate	1/27 (4%)	4/24 (17%)	1/24 (4%)	4/32 (13%)
First incidence (days)	679	575	734 (T)	549
Life table test	P= 0.229	P= 0.188	P= 0.514N	P= 0.189
Logistic regression test	P= 0.170	P= 0.225	P= 0.472N	P= 0.146
Cochran-Armitage test	P= 0.151			
Fisher exact test		P= 0.218	P= 0.500N	P= 0.134
Uterus: Stromal Polyp or Stromal Sarcoma				
Overall rate	2/50 (4%)	6/50 (12%)	1/50 (2%)	7/50 (14%)
Adjusted rate	6.5%	21.0%	4.2%	18.0%
Terminal rate	1/27 (4%)	4/24 (17%)	1/24 (4%)	4/32 (13%)
First incidence (days)	679	575	734 (T)	441
Life table test	P= 0.174	P= 0.117	P= 0.514N	P= 0.123
Logistic regression test	P= 0.110	P= 0.141	P= 0.472N	P= 0.071
Cochran-Armitage test	P= 0.109			
Fisher exact test		P= 0.134	P= 0.500N	P= 0.080
All Organs: Mononuclear Cell Leukemia				
Overall rate	12/50 (24%)	19/50 (38%)	18/50 (36%)	25/50 (50%)
Adjusted rate	28.7%	54.0%	46.5%	57.4%
Terminal rate	2/27 (7%)	9/24 (38%)	6/24 (25%)	14/32 (44%)
First incidence (days)	428	608	580	541
Life table test	P= 0.065	P= 0.116	P= 0.201	P= 0.047
Logistic regression test	P= 0.008	P= 0.094	P= 0.087	P= 0.005
Cochran-Armitage test	P= 0.008			
Fisher exact test		P= 0.097	P= 0.138	P= 0.006
All Organs: Benign Neoplasms				
Overall rate	44/50 (88%)	37/50 (74%)	44/50 (88%)	41/50 (82%)
Adjusted rate	97.8%	89.4%	97.7%	97.6%
Terminal rate	26/27 (96%)	20/24 (83%)	23/24 (96%)	31/32 (97%)
First incidence (days)	400	511	487	511
Life table test	P= 0.103N	P= 0.269N	P= 0.479	P= 0.070N
Logistic regression test	P= 0.249N	P= 0.034N	P= 0.279N	P= 0.053N
Cochran-Armitage test	P= 0.475N			
Fisher exact test		P= 0.062N	P= 0.620N	P= 0.288N

TABLE B3
Statistical Analysis of Primary Neoplasms in Female Rats in the 2-Year Inhalation Study of Isobutyraldehyde (continued)

	Chamber Control	500 ppm	1,000 ppm	2,000 ppm
All Organs: Malignant Neoplasms				
Overall rate	21/50 (42%)	30/50 (60%)	25/50 (50%)	30/50 (60%)
Adjusted rate	50.4%	74.3%	61.8%	65.9%
Terminal rate	8/27 (30%)	14/24 (58%)	10/24 (42%)	17/32 (53%)
First incidence (days)	428	511	580	441
Life table test	P= 0.368	P= 0.081	P= 0.330	P= 0.231
Logistic regression test	P= 0.101	P= 0.058	P= 0.367	P= 0.041
Cochran-Armitage test	P= 0.098			
Fisher exact test		P= 0.055	P= 0.274	P= 0.055
All Organs: Benign or Malignant Neoplasms				
Overall rate	48/50 (96%)	49/50 (98%)	50/50 (100%)	49/50 (98%)
Adjusted rate	98.0%	100.0%	100.0%	98.0%
Terminal rate	26/27 (96%)	24/24 (100%)	24/24 (100%)	31/32 (97%)
First incidence (days)	400	511	487	441
Life table test	P= 0.158N	P= 0.367	P= 0.395	P= 0.239N
Logistic regression test	P= 0.624N	P= 0.613	P= 0.494	P= 0.697
Cochran-Armitage test	P= 0.366			
Fisher exact test		P= 0.500	P= 0.247	P= 0.500

(T)Terminal sacrifice

- ^a Number of neoplasm-bearing animals/number of animals examined. Denominator is number of animals examined microscopically for clitoral gland, lung, pituitary gland, and thyroid gland; for other tissues, denominator is number of animals necropsied.
- ^b Kaplan-Meier estimated neoplasm incidence at the end of the study after adjustment for intercurrent mortality
- ^c Observed incidence at terminal kill
- ^d Beneath the chamber control incidence are the P values associated with the trend test. Beneath the exposed group incidence are the P values corresponding to pairwise comparisons between the chamber controls and that exposed group. The life table test regards neoplasms in animals dying prior to terminal kill as being (directly or indirectly) the cause of death. The logistic regression test regards these lesions as nonfatal. The Cochran-Armitage and Fisher exact tests compare directly the overall incidence rates. For all tests, a negative trend or a lower incidence in an exposure group is indicated by **N**.
- ^e Not applicable; no neoplasms in animal group

TABLE B4a
Historical Incidence of Fibrosarcoma of the Nose in Chamber Control Female F344/N Rats^a

Study	Incidence in Controls
Historical Incidence at Battelle Pacific Northwest Laboratories	
CS2 (<i>o</i> -Chlorobenzalmalononitrile)	0/49
Acetonitrile	0/47
2-Chloroacetophenone	1/48
<i>l</i> -Epinephrine Hydrochloride	0/50
Chloroethane	0/50
Hexachlorocyclopentadiene	0/50
Ozone	0/50
Overall Historical Incidence	
Total	1/645 (0.2%)
Standard deviation	0.6%
Range	0%-2%

^a Data as of 12 May 1995

TABLE B4b
Historical Incidence of Mononuclear Cell Leukemia in Chamber Control Female F344/N Rats^a

Study	Incidence in Controls
Historical Incidence at Battelle Pacific Northwest Laboratories	
CS2 (<i>o</i> -Chlorobenzalmalononitrile)	24/50
Acetonitrile	18/48
2-Chloroacetophenone	27/50
<i>l</i> -Epinephrine Hydrochloride	24/50
Chloroethane	20/50
Hexachlorocyclopentadiene	16/50
Ozone	17/50
Overall Historical Incidence	
Total	262/653 (40.1%)
Standard deviation	7.2%
Range	30%-54%

^a Data as of 12 May 1995. Includes data for lymphocytic, monocytic, mononuclear cell, and undifferentiated cell type leukemias

TABLE B5
Summary of the Incidence of Nonneoplastic Lesions in Female Rats in the 2-Year Inhalation Study of Isobutyraldehyde^a

	Chamber Control	500 ppm	1,000 ppm	2,000 ppm
Disposition Summary				
Animals initially in study	50	50	50	50
Early deaths				
Accidental death		1		
Moribund	17	22	22	13
Natural deaths	6	3	4	5
Survivors				
Died last week of study				1
Terminal sacrifice	27	24	24	31
Animals examined microscopically	50	50	50	50
Alimentary System				
Esophagus	(49)	(50)	(50)	(50)
Periesophageal tissue, inflammation, chronic active	1 (2%)			
Intestine large, colon	(48)	(47)	(49)	(47)
Diverticulum	1 (2%)			
Parasite metazoan	3 (6%)	2 (4%)	3 (6%)	2 (4%)
Intestine large, rectum	(48)	(47)	(49)	(47)
Parasite metazoan	6 (13%)	2 (4%)	3 (6%)	4 (9%)
Intestine large, cecum	(48)	(47)	(49)	(45)
Diverticulum			1 (2%)	
Parasite metazoan	4 (8%)		1 (2%)	
Intestine small, ileum	(47)	(47)	(49)	(45)
Parasite metazoan		1 (2%)		
Liver	(49)	(50)	(50)	(50)
Angiectasis	1 (2%)	1 (2%)		
Basophilic focus	2 (4%)		3 (6%)	
Basophilic focus, multiple	3 (6%)			
Clear cell focus	4 (8%)	5 (10%)	3 (6%)	3 (6%)
Clear cell focus, multiple	5 (10%)	1 (2%)	3 (6%)	2 (4%)
Eosinophilic focus		1 (2%)		1 (2%)
Hepatodiaphragmatic nodule	6 (12%)	6 (12%)	7 (14%)	5 (10%)
Inflammation, granulomatous	2 (4%)			
Vacuolization cytoplasmic	5 (10%)	2 (4%)	2 (4%)	7 (14%)
Hepatocyte, hyperplasia	1 (2%)			
Hepatocyte, necrosis				1 (2%)
Serosa, hemorrhage	1 (2%)			
Mesentery	(7)	(7)	(8)	(4)
Artery, inflammation, chronic		1 (14%)		
Fat, necrosis	5 (71%)	4 (57%)	6 (75%)	4 (100%)
Oral mucosa	(4)		(2)	(3)
Fibrosis	1 (25%)			
Hyperplasia	1 (25%)			
Inflammation, chronic	1 (25%)			
Inflammation, suppurative			1 (50%)	
Gingival, inflammation, suppurative			1 (50%)	
Pharyngeal, hyperplasia	2 (50%)		1 (50%)	2 (67%)
Pancreas	(49)	(49)	(49)	(50)
Atrophy	3 (6%)	2 (4%)	3 (6%)	
Artery, inflammation, chronic		1 (2%)		

^a Number of animals examined microscopically at the site and the number of animals with lesion

TABLE B5
Summary of the Incidence of Nonneoplastic Lesions in Female Rats in the 2-Year Inhalation Study
of Isobutyraldehyde (continued)

	Chamber Control	500 ppm	1,000 ppm	2,000 ppm
Alimentary System (continued)				
Stomach, forestomach	(49)	(49)	(50)	(50)
Hyperkeratosis	1 (2%)			
Hyperplasia	5 (10%)	2 (4%)	5 (10%)	5 (10%)
Inflammation, suppurative	1 (2%)		1 (2%)	
Ulcer	1 (2%)	2 (4%)	5 (10%)	2 (4%)
Tongue	(1)		(1)	(2)
Epithelium, hyperplasia	1 (100%)			1 (50%)
Tooth	(1)	(1)	(2)	
Developmental malformation	1 (100%)		1 (50%)	
Inflammation, suppurative		1 (100%)	1 (50%)	
Cardiovascular System				
Heart	(50)	(50)	(50)	(50)
Cardiomyopathy	1 (2%)			2 (4%)
Atrium, thrombosis	2 (4%)			
Endocrine System				
Adrenal cortex	(49)	(49)	(50)	(50)
Hyperplasia	1 (2%)			
Vacuolization cytoplasmic	12 (24%)	5 (10%)	9 (18%)	11 (22%)
Adrenal medulla	(49)	(49)	(47)	(49)
Hyperplasia	4 (8%)	2 (4%)		
Islets, pancreatic	(50)	(48)	(49)	(50)
Hyperplasia	1 (2%)	1 (2%)		
Pituitary gland	(48)	(50)	(49)	(50)
Cyst	6 (13%)	14 (28%)	13 (27%)	11 (22%)
Hemorrhage		2 (4%)	2 (4%)	
Pars distalis, hyperplasia	9 (19%)	6 (12%)	6 (12%)	5 (10%)
Pars distalis, hypertrophy			1 (2%)	
Thyroid gland	(49)	(49)	(50)	(50)
C-cell, hyperplasia	8 (16%)	7 (14%)	9 (18%)	6 (12%)
Follicular cell, hyperplasia			1 (2%)	
General Body System				
None				
Genital System				
Clitoral gland	(48)	(50)	(50)	(48)
Cyst	7 (15%)	11 (22%)	14 (28%)	9 (19%)
Hyperplasia	2 (4%)	4 (8%)	1 (2%)	1 (2%)
Inflammation, suppurative	2 (4%)	1 (2%)	1 (2%)	3 (6%)
Ovary	(49)	(50)	(50)	(50)
Cyst		1 (2%)	3 (6%)	2 (4%)
Uterus	(48)	(50)	(50)	(50)
Cyst		1 (2%)	1 (2%)	
Cervix, hypertrophy			1 (2%)	
Endometrium, cyst				1 (2%)
Endometrium, hyperplasia	1 (2%)	1 (2%)	2 (4%)	
Endometrium, metaplasia, squamous			1 (2%)	

TABLE B5
Summary of the Incidence of Nonneoplastic Lesions in Female Rats in the 2-Year Inhalation Study
of Isobutyraldehyde (continued)

	Chamber Control	500 ppm	1,000 ppm	2,000 ppm
Hematopoietic System				
Lymph node	(4)	(4)	(4)	(5)
Renal, pigmentation			1 (25%)	
Lymph node, mandibular	(45)	(50)	(46)	(46)
Angiectasis		1 (2%)		
Hemorrhage		1 (2%)		
Hyperplasia, lymphoid	1 (2%)		1 (2%)	
Lymph node, mesenteric	(49)	(50)	(50)	(50)
Angiectasis	1 (2%)			
Hemorrhage	1 (2%)		2 (4%)	
Hyperplasia, lymphoid			1 (2%)	
Lymph node, mediastinal	(48)	(49)	(50)	(50)
Fibrosis		1 (2%)		
Hyperplasia, lymphoid	1 (2%)			
Spleen	(49)	(49)	(49)	(50)
Accessory spleen	4 (8%)	1 (2%)	2 (4%)	
Angiectasis		1 (2%)		
Fibrosis	2 (4%)	2 (4%)	1 (2%)	4 (8%)
Hematopoietic cell proliferation	1 (2%)	1 (2%)	1 (2%)	1 (2%)
Hemorrhage	1 (2%)	2 (4%)		2 (4%)
Thymus	(48)	(50)	(50)	(50)
Cyst		1 (2%)	1 (2%)	
Integumentary System				
Mammary gland	(50)	(50)	(50)	(50)
Galactocele	1 (2%)		3 (6%)	1 (2%)
Inflammation, chronic	1 (2%)			
Epithelium, hyperplasia		1 (2%)		
Skin	(49)	(50)	(50)	(50)
Hyperkeratosis	1 (2%)	4 (8%)	1 (2%)	
Hyperplasia	1 (2%)			
Inflammation, granulomatous	1 (2%)			
Inflammation, suppurative		1 (2%)		1 (2%)
Ulcer	1 (2%)	3 (6%)	1 (2%)	
Epidermis, cyst		2 (4%)	1 (2%)	1 (2%)
Musculoskeletal System				
Bone	(49)	(50)	(50)	(50)
Hyperostosis				1 (2%)
Cranium, fracture		1 (2%)		
Cranium, femur, osteopetrosis		1 (2%)		
Maxilla, fracture		1 (2%)		
Nervous System				
Brain	(49)	(49)	(50)	(50)
Gliosis		1 (2%)		
Hemorrhage	4 (8%)	2 (4%)	5 (10%)	1 (2%)
Necrosis		1 (2%)		
Ventricle, hydrocephalus	5 (10%)	3 (6%)	3 (6%)	2 (4%)

TABLE B5
Summary of the Incidence of Nonneoplastic Lesions in Female Rats in the 2-Year Inhalation Study
of Isobutyraldehyde (continued)

	Chamber Control	500 ppm	1,000 ppm	2,000 ppm
Respiratory System				
Larynx	(49)	(50)	(48)	(50)
Foreign body	6 (12%)	2 (4%)	7 (15%)	4 (8%)
Inflammation, suppurative		1 (2%)	3 (6%)	6 (12%)
Epiglottis, metaplasia, squamous	2 (4%)		4 (8%)	6 (12%)
Epithelium, hyperplasia	5 (10%)	1 (2%)		1 (2%)
Epithelium, metaplasia, squamous	5 (10%)	1 (2%)	6 (13%)	10 (20%)
Glands, inflammation, suppurative	5 (10%)	11 (22%)	4 (8%)	8 (16%)
Lung	(49)	(50)	(50)	(50)
Hemorrhage	3 (6%)		4 (8%)	4 (8%)
Inflammation, granulomatous	1 (2%)			
Alveolar epithelium, fibrosis	4 (8%)	2 (4%)	2 (4%)	2 (4%)
Alveolar epithelium, foreign body	1 (2%)			
Alveolar epithelium, hyperplasia	1 (2%)	6 (12%)	3 (6%)	3 (6%)
Alveolar epithelium, infiltration cellular, histiocyte	10 (20%)	10 (20%)	11 (22%)	7 (14%)
Bronchiole, hyperplasia	1 (2%)			
Nose	(49)	(50)	(49)	(50)
Cyst		2 (4%)	5 (10%)	
Foreign body	2 (4%)	2 (4%)	5 (10%)	5 (10%)
Hemorrhage		1 (2%)		
Inflammation, suppurative	2 (4%)	3 (6%)	5 (10%)	11 (22%)
Nasolacrimal duct, inflammation, suppurative	1 (2%)			1 (2%)
Nasolacrimal duct, metaplasia, squamous	1 (2%)			1 (2%)
Olfactory epithelium, degeneration			2 (4%)	45 (90%)
Respiratory epithelium, hyperplasia	1 (2%)		1 (2%)	1 (2%)
Respiratory epithelium, metaplasia, squamous	1 (2%)	11 (22%)	9 (18%)	44 (88%)
Pleura	(1)	(1)		
Inflammation	1 (100%)			
Special Senses System				
Eye	(3)	(2)	(1)	(1)
Cornea, mineralization		1 (50%)		
Lens, cataract	2 (67%)	1 (50%)	1 (100%)	1 (100%)
Urinary System				
Kidney	(49)	(49)	(50)	(50)
Nephropathy, chronic	35 (71%)	30 (61%)	30 (60%)	36 (72%)
Cortex, necrosis				1 (2%)
Medulla, renal tubule, cyst	1 (2%)			
Pelvis, dilatation			1 (2%)	1 (2%)
Renal tubule, degeneration				1 (2%)
Renal tubule, inflammation, suppurative			1 (2%)	1 (2%)
Renal tubule, mineralization	5 (10%)	2 (4%)	5 (10%)	2 (4%)
Urinary bladder	(49)	(49)	(50)	(50)
Hemorrhage			1 (2%)	1 (2%)
Transitional epithelium, hyperplasia	2 (4%)			

APPENDIX C
SUMMARY OF LESIONS IN MALE MICE
IN THE 2-YEAR INHALATION STUDY
OF ISOBUTYRALDEHYDE

TABLE C1	Summary of the Incidence of Neoplasms in Male Mice in the 2-Year Inhalation Study of Isobutylaldehyde	120
TABLE C2	Individual Animal Tumor Pathology of Male Mice in the 2-Year Inhalation Study of Isobutylaldehyde	124
TABLE C3	Statistical Analysis of Primary Neoplasms in Male Mice in the 2-Year Inhalation Study of Isobutylaldehyde	142
TABLE C4	Historical Incidence of Malignant Lymphoma in Chamber Control Male B6C3F₁ Mice	145
TABLE C5	Summary of the Incidence of Nonneoplastic Lesions in Male Mice in the 2-Year Inhalation Study of Isobutylaldehyde	146

TABLE C1
Summary of the Incidence of Neoplasms in Male Mice in the 2-Year Inhalation Study of Isobutyraldehyde^a

	Chamber Control	500 ppm	1,000 ppm	2,000 ppm
Disposition Summary				
Animals initially in study	50	50	50	50
Early deaths				
Moribund	6	8	6	15
Natural deaths	4	5	9	5
Survivors				
Terminal sacrifice	40	37	35	30
Animals examined microscopically	50	50	50	50
Alimentary System				
Intestine large, rectum	(49)	(49)	(50)	(49)
Sarcoma, metastatic, skin	1 (2%)			
Intestine large, cecum	(49)	(48)	(48)	(48)
Leiomyoma	1 (2%)			
Intestine small, jejunum	(49)	(49)	(48)	(46)
Hepatocolangiocarcinoma, metastatic, liver		1 (2%)		
Intestine small, ileum	(49)	(49)	(47)	(48)
Liver	(49)	(50)	(50)	(50)
Carcinoma, metastatic, parathyroid gland				1 (2%)
Cholangioma	1 (2%)			
Hemangiosarcoma	1 (2%)			
Hepatocellular carcinoma	14 (29%)	12 (24%)	9 (18%)	8 (16%)
Hepatocellular carcinoma, multiple	3 (6%)	2 (4%)	3 (6%)	5 (10%)
Hepatocellular adenoma	8 (16%)	13 (26%)	14 (28%)	6 (12%)
Hepatocellular adenoma, multiple	4 (8%)	1 (2%)	1 (2%)	1 (2%)
Hepatocolangiocarcinoma		1 (2%)		
Mesentery	(1)	(3)	(5)	(3)
Hepatocellular carcinoma, metastatic, liver				1 (33%)
Artery, fibrous histiocytoma			1 (20%)	
Pancreas	(50)	(49)	(50)	(50)
Artery, fibrous histiocytoma			1 (2%)	
Stomach, forestomach	(50)	(50)	(50)	(50)
Squamous cell papilloma	1 (2%)		1 (2%)	
Stomach, glandular	(50)	(50)	(49)	(50)
Hepatocolangiocarcinoma, metastatic, liver		1 (2%)		
Artery, fibrous histiocytoma			1 (2%)	
Tooth		(3)	(2)	
Odontoma			1 (50%)	
Cardiovascular System				
None				
Endocrine System				
Adrenal cortex	(50)	(50)	(50)	(50)
Adenoma	1 (2%)	1 (2%)		
Carcinoma, metastatic, parathyroid gland				1 (2%)
Capsule, adenoma	1 (2%)		1 (2%)	1 (2%)
Adrenal medulla	(50)	(50)	(50)	(50)
Pheochromocytoma benign		1 (2%)		1 (2%)

TABLE C1
Summary of the Incidence of Neoplasms in Male Mice in the 2-Year Inhalation Study of Isobutyraldehyde (continued)

	Chamber Control	500 ppm	1,000 ppm	2,000 ppm
Endocrine System (continued)				
Islets, pancreatic	(50)	(49)	(50)	(50)
Adenoma	1 (2%)		1 (2%)	1 (2%)
Parathyroid gland	(43)	(41)	(45)	(42)
Carcinoma				1 (2%)
Thyroid gland	(50)	(50)	(50)	(50)
C-cell, carcinoma			1 (2%)	
Follicular cell, adenoma	3 (6%)	2 (4%)	1 (2%)	5 (10%)
Follicular cell, carcinoma	1 (2%)		1 (2%)	
General Body System				
None				
Genital System				
Epididymis	(50)	(50)	(50)	(50)
Leiomyoma				1 (2%)
Seminal vesicle	(50)	(50)	(50)	(50)
Carcinoma	1 (2%)			
Carcinoma, metastatic, parathyroid gland				1 (2%)
Testes	(50)	(50)	(50)	(50)
Interstitial cell, adenoma				1 (2%)
Hematopoietic System				
Bone marrow	(50)	(50)	(50)	(50)
Carcinoma, metastatic, parathyroid gland				1 (2%)
Hemangiosarcoma	1 (2%)		1 (2%)	
Lymph node				(4)
Lymph node, bronchial	(37)	(34)	(33)	(34)
Lymph node, mandibular	(27)	(25)	(36)	(31)
Lymph node, mesenteric	(50)	(48)	(47)	(47)
Lymph node, mediastinal	(29)	(34)	(28)	(34)
Alveolar/bronchiolar carcinoma, metastatic, lung			1 (4%)	
Fibrosarcoma, metastatic, skin	1 (3%)			
Spleen	(50)	(50)	(50)	(50)
Hemangiosarcoma	1 (2%)	2 (4%)	1 (2%)	
Thymus	(39)	(39)	(42)	(36)
Fibrous histiocyoma			1 (2%)	
Integumentary System				
Skin	(49)	(50)	(50)	(50)
Fibrous histiocyoma			1 (2%)	
Mast cell tumor benign			1 (2%)	
Squamous cell carcinoma		1 (2%)		
Squamous cell papilloma			1 (2%)	
Subcutaneous tissue, fibrosarcoma	1 (2%)			
Subcutaneous tissue, hemangiosarcoma				1 (2%)
Subcutaneous tissue, sarcoma	1 (2%)		1 (2%)	

TABLE C1
Summary of the Incidence of Neoplasms in Male Mice in the 2-Year Inhalation Study of Isobutyraldehyde (continued)

	Chamber Control	500 ppm	1,000 ppm	2,000 ppm
Musculoskeletal System				
Bone	(50)	(50)	(50)	(50)
Hemangiosarcoma			1 (2%)	
Skeletal muscle			(1)	
Hemangiosarcoma			1 (100%)	
Nervous System				
None				
Respiratory System				
Larynx	(50)	(49)	(50)	(50)
Carcinoma, metastatic, parathyroid gland				1 (2%)
Lung	(50)	(50)	(50)	(50)
Alveolar/bronchiolar adenoma	5 (10%)	2 (4%)	6 (12%)	4 (8%)
Alveolar/bronchiolar adenoma, multiple		1 (2%)		1 (2%)
Alveolar/bronchiolar carcinoma	6 (12%)	6 (12%)	3 (6%)	6 (12%)
Alveolar/bronchiolar carcinoma, multiple	1 (2%)		1 (2%)	
Carcinoma, metastatic, harderian gland			1 (2%)	
Carcinoma, metastatic, parathyroid gland				1 (2%)
Carcinoma, metastatic, thyroid gland	1 (2%)		1 (2%)	
Hepatocellular carcinoma, metastatic, liver		4 (8%)	4 (8%)	5 (10%)
Hepatocholangiocarcinoma, metastatic, liver		1 (2%)		
Sarcoma, metastatic, skin	1 (2%)			
Artery, fibrous histiocytoma			1 (2%)	
Artery, mediastinum, fibrous histiocytoma			1 (2%)	
Mediastinum, alveolar/bronchiolar carcinoma, metastatic, lung	1 (2%)		1 (2%)	
Mediastinum, fibrosarcoma, metastatic, skin	1 (2%)			
Mediastinum, hepatocholangiocarcinoma, metastatic, liver		1 (2%)		
Nose	(50)	(50)	(50)	(50)
Vomer nasal organ, adenoma	1 (2%)			
Trachea	(50)	(50)	(50)	(50)
Carcinoma, metastatic, parathyroid gland				1 (2%)
Special Senses System				
Harderian gland	(3)	(2)	(3)	(2)
Adenoma	1 (33%)		1 (33%)	2 (100%)
Carcinoma	2 (67%)	2 (100%)	1 (33%)	
Sarcoma			1 (33%)	
Urinary System				
Kidney	(50)	(50)	(50)	(50)
Carcinoma, metastatic, parathyroid gland				1 (2%)
Hepatocellular carcinoma, metastatic, liver				1 (2%)
Hepatocholangiocarcinoma, metastatic, liver		1 (2%)		
Urinary bladder	(50)	(50)	(48)	(50)
Carcinoma, metastatic, parathyroid gland				1 (2%)
Artery, fibrous histiocytoma			1 (2%)	

TABLE C1
Summary of the Incidence of Neoplasms in Male Mice in the 2-Year Inhalation Study of Isobutyraldehyde (continued)

	Chamber Control	500 ppm	1,000 ppm	2,000 ppm
Systemic Lesions				
Multiple organs ^b	(50)	(50)	(50)	(50)
Lymphoma malignant	1 (2%)	5 (10%)	1 (2%)	6 (12%)
Neoplasm Summary				
Total animals with primary neoplasms ^c	40	36	39	34
Total primary neoplasms	62	52	63	51
Total animals with benign neoplasms	22	19	22	19
Total benign neoplasms	28	21	29	24
Total animals with malignant neoplasms	28	27	22	25
Total malignant neoplasms	34	31	34	27
Total animals with metastatic neoplasms	4	5	7	7
Total metastatic neoplasms	6	9	8	16

^a Number of animals examined microscopically at the site and the number of animals with neoplasm

^b Number of animals with any tissue examined microscopically

^c Primary neoplasms: all neoplasms except metastatic neoplasms

TABLE C2
Individual Animal Tumor Pathology of Male Mice in the 2-Year Inhalation Study of Isobutyraldehyde: 1,000 ppm
 (continued)

Number of Days on Study	7 7 7 7 7 7 7 7 7 7 7 7 7 7 7 7 7 7 7 7 7 7 7 7	
	3 3 3 3 3 3 3 3 3 3 3 3 3 3 3 3 3 3 3 3 3 3 3 3	
	3 3 3 3 3 3 3 3 4 4 4 4 4 4 4 4 4 4 4 4 5 5 5 5	
Carcass ID Number	4 4 4 4 4 4 4 4 4 4 4 4 4 4 4 4 4 4 4 4 4 4 4 4	Total
	3 3 3 4 4 4 4 4 0 0 0 1 1 1 2 2 3 3 4 5 0 1 2 2 2	Tissues/
	1 3 7 1 3 5 7 8 5 6 7 4 5 8 1 7 5 8 6 0 4 6 2 3 5	Tumors
Special Senses System		
Ear		1
Eye	+	1
Harderian gland		3
Adenoma		1
Carcinoma		1
Sarcoma		1
Urinary System		
Kidney	+ + + + + + + + + + + + + + + + + + + + + + + +	50
Urinary bladder	+ + + + + + + + + + + + + + + + + + + + + + + +	48
Artery, fibrous histiocytoma	X	1
Systemic Lesions		
Multiple organs	+ + + + + + + + + + + + + + + + + + + + + + + +	50
Lymphoma malignant	X	1

TABLE C3
Statistical Analysis of Primary Neoplasms in Male Mice in the 2-Year Inhalation Study of Isobutyraldehyde

	Chamber Control	500 ppm	1,000 ppm	2,000 ppm
Harderian Gland: Adenoma or Carcinoma				
Overall rate ^a	3/50 (6%)	2/50 (4%)	2/50 (4%)	2/50 (4%)
Adjusted rate ^b	7.5%	4.7%	5.5%	6.7%
Terminal rate ^c	3/40 (8%)	1/37 (3%)	1/35 (3%)	2/30 (7%)
First incidence (days)	733 (T)	580	711	733 (T)
Life table test ^d	P= 0.543N	P= 0.528N	P= 0.555N	P= 0.630N
Logistic regression test ^d	P= 0.463N	P= 0.495N	P= 0.556N	P= 0.630N
Cochran-Armitage test ^d	P= 0.431N			
Fisher exact test ^d		P= 0.500N	P= 0.500N	P= 0.500N
Liver: Hepatocellular Adenoma				
Overall rate	12/49 (24%)	14/50 (28%)	15/50 (30%)	7/50 (14%)
Adjusted rate	29.7%	33.4%	38.1%	19.0%
Terminal rate	11/39 (28%)	10/37 (27%)	11/35 (31%)	3/30 (10%)
First incidence (days)	639	605	535	639
Life table test	P= 0.282N	P= 0.354	P= 0.219	P= 0.320N
Logistic regression test	P= 0.124N	P= 0.422	P= 0.250	P= 0.174N
Cochran-Armitage test	P= 0.100N			
Fisher exact test		P= 0.433	P= 0.349	P= 0.142N
Liver: Hepatocellular Carcinoma				
Overall rate	17/49 (35%)	14/50 (28%)	12/50 (24%)	13/50 (26%)
Adjusted rate	37.3%	30.2%	27.9%	32.4%
Terminal rate	11/39 (28%)	5/37 (14%)	6/35 (17%)	5/30 (17%)
First incidence (days)	639	580	410	547
Life table test	P= 0.448N	P= 0.410N	P= 0.326N	P= 0.501N
Logistic regression test	P= 0.092N	P= 0.258N	P= 0.120N	P= 0.123N
Cochran-Armitage test	P= 0.212N			
Fisher exact test		P= 0.308N	P= 0.172N	P= 0.235N
Liver: Hepatocellular Adenoma or Carcinoma				
Overall rate	27/49 (55%)	25/50 (50%)	26/50 (52%)	18/50 (36%)
Adjusted rate	58.4%	52.1%	57.4%	43.8%
Terminal rate	20/39 (51%)	14/37 (38%)	16/35 (46%)	8/30 (27%)
First incidence (days)	639	580	410	547
Life table test	P= 0.276N	P= 0.523N	P= 0.427	P= 0.289N
Logistic regression test	P= 0.012N	P= 0.291N	P= 0.567N	P= 0.020N
Cochran-Armitage test	P= 0.035N			
Fisher exact test		P= 0.380N	P= 0.457N	P= 0.044N
Lung: Alveolar/bronchiolar Adenoma				
Overall rate	5/50 (10%)	3/50 (6%)	6/50 (12%)	5/50 (10%)
Adjusted rate	12.1%	7.8%	17.1%	15.7%
Terminal rate	4/40 (10%)	2/37 (5%)	6/35 (17%)	4/30 (13%)
First incidence (days)	682	712	733 (T)	670
Life table test	P= 0.281	P= 0.396N	P= 0.408	P= 0.459
Logistic regression test	P= 0.352	P= 0.371N	P= 0.414	P= 0.556
Cochran-Armitage test	P= 0.451			
Fisher exact test		P= 0.357N	P= 0.500	P= 0.630N

TABLE C3
Statistical Analysis of Primary Neoplasms in Male Mice in the 2-Year Inhalation Study of Isobutyraldehyde (continued)

	Chamber Control	500 ppm	1,000 ppm	2,000 ppm
Lung: Alveolar/bronchiolar Carcinoma				
Overall rate	7/50 (14%)	6/50 (12%)	4/50 (8%)	6/50 (12%)
Adjusted rate	15.6%	16.2%	10.7%	16.5%
Terminal rate	4/40 (10%)	6/37 (16%)	3/35 (9%)	3/30 (10%)
First incidence (days)	455	733 (T)	535	499
Life table test	P= 0.529	P= 0.557N	P= 0.352N	P= 0.582
Logistic regression test	P= 0.417N	P= 0.487N	P= 0.224N	P= 0.399N
Cochran-Armitage test	P= 0.426N			
Fisher exact test		P= 0.500N	P= 0.262N	P= 0.500N
Lung: Alveolar/bronchiolar Adenoma or Carcinoma				
Overall rate	12/50 (24%)	8/50 (16%)	10/50 (20%)	10/50 (20%)
Adjusted rate	26.7%	21.0%	27.4%	27.8%
Terminal rate	8/40 (20%)	7/37 (19%)	9/35 (26%)	6/30 (20%)
First incidence (days)	455	712	535	499
Life table test	P= 0.398	P= 0.291N	P= 0.547N	P= 0.550
Logistic regression test	P= 0.488N	P= 0.224N	P= 0.454N	P= 0.355N
Cochran-Armitage test	P= 0.452N			
Fisher exact test		P= 0.227N	P= 0.405N	P= 0.405N
Thyroid Gland (Follicular Cell): Adenoma				
Overall rate	3/50 (6%)	2/50 (4%)	1/50 (2%)	5/50 (10%)
Adjusted rate	7.0%	5.4%	2.9%	16.0%
Terminal rate	2/40 (5%)	2/37 (5%)	1/35 (3%)	4/30 (13%)
First incidence (days)	639	733 (T)	733 (T)	723
Life table test	P= 0.129	P= 0.538N	P= 0.362N	P= 0.229
Logistic regression test	P= 0.168	P= 0.504N	P= 0.332N	P= 0.298
Cochran-Armitage test	P= 0.216			
Fisher exact test		P= 0.500N	P= 0.309N	P= 0.357
Thyroid Gland (Follicular Cell): Adenoma or Carcinoma				
Overall rate	4/50 (8%)	2/50 (4%)	2/50 (4%)	5/50 (10%)
Adjusted rate	9.0%	5.4%	5.3%	16.0%
Terminal rate	2/40 (5%)	2/37 (5%)	1/35 (3%)	4/30 (13%)
First incidence (days)	639	733 (T)	649	723
Life table test	P= 0.225	P= 0.380N	P= 0.415N	P= 0.355
Logistic regression test	P= 0.301	P= 0.331N	P= 0.331N	P= 0.470
Cochran-Armitage test	P= 0.331			
Fisher exact test		P= 0.339N	P= 0.339N	P= 0.500
All Organs: Malignant Lymphoma				
Overall rate	1/50 (2%)	5/50 (10%)	1/50 (2%)	6/50 (12%)
Adjusted rate	2.1%	13.5%	2.9%	16.8%
Terminal rate	0/40 (0%)	5/37 (14%)	1/35 (3%)	2/30 (7%)
First incidence (days)	639	733 (T)	733 (T)	665
Life table test	P= 0.042	P= 0.087	P= 0.722	P= 0.038
Logistic regression test	P= 0.067	P= 0.100	P= 0.766N	P= 0.063
Cochran-Armitage test	P= 0.080			
Fisher exact test		P= 0.102	P= 0.753N	P= 0.056

TABLE C3
Statistical Analysis of Primary Neoplasms in Male Mice in the 2-Year Inhalation Study of Isobutyraldehyde (continued)

	Chamber Control	500 ppm	1,000 ppm	2,000 ppm
All Organs: Benign Neoplasms				
Overall rate	22/50 (44%)	19/50 (38%)	22/50 (44%)	19/50 (38%)
Adjusted rate	50.9%	44.7%	54.5%	51.7%
Terminal rate	19/40 (48%)	14/37 (38%)	17/35 (49%)	13/30 (43%)
First incidence (days)	639	605	359	616
Life table test	P= 0.309	P= 0.462N	P= 0.356	P= 0.409
Logistic regression test	P= 0.455N	P= 0.364N	P= 0.444	P= 0.474N
Cochran-Armitage test	P= 0.367N			
Fisher exact test		P= 0.342N	P= 0.580N	P= 0.342N
All Organs: Malignant Neoplasms				
Overall rate	28/50 (56%)	27/50 (54%)	22/50 (44%)	25/50 (50%)
Adjusted rate	56.0%	57.3%	49.1%	56.1%
Terminal rate	18/40 (45%)	17/37 (46%)	13/35 (37%)	11/30 (37%)
First incidence (days)	455	573	322	499
Life table test	P= 0.406	P= 0.512	P= 0.389N	P= 0.404
Logistic regression test	P= 0.127N	P= 0.464N	P= 0.090N	P= 0.155N
Cochran-Armitage test	P= 0.267N			
Fisher exact test		P= 0.500N	P= 0.159N	P= 0.344N
All Organs: Benign or Malignant Neoplasms				
Overall rate	40/50 (80%)	36/50 (72%)	39/50 (78%)	34/50 (68%)
Adjusted rate	80.0%	73.5%	81.2%	73.7%
Terminal rate	30/40 (75%)	24/37 (65%)	26/35 (74%)	18/30 (60%)
First incidence (days)	455	573	322	499
Life table test	P= 0.318	P= 0.473N	P= 0.304	P= 0.414
Logistic regression test	P= 0.081N	P= 0.223N	P= 0.474N	P= 0.073N
Cochran-Armitage test	P= 0.142N			
Fisher exact test		P= 0.241N	P= 0.500N	P= 0.127N

(T)Terminal sacrifice

^a Number of neoplasm-bearing animals/number of animals examined. Denominator is number of animals examined microscopically for liver, lung, and thyroid gland; for other tissues, denominator is number of animals necropsied.

^b Kaplan-Meier estimated neoplasm incidence at the end of the study after adjustment for intercurrent mortality

^c Observed incidence at terminal kill

^d Beneath the chamber control incidence are the P values associated with the trend test. Beneath the exposed group incidence are the P values corresponding to pairwise comparisons between the chamber controls and that exposed group. The life table test regards neoplasms in animals dying prior to terminal kill as being (directly or indirectly) the cause of death. The logistic regression test regards these lesions as nonfatal. The Cochran-Armitage and Fisher exact tests compare directly the overall incidence rates. For all tests, a negative trend or a lower incidence in an exposure group is indicated by N.

TABLE C4
Historical Incidence of Malignant Lymphoma in Chamber Control Male B6C3F₁ Mice^a

Study	Incidence in Controls
Historical Incidence at Battelle Pacific Northwest Laboratories	
1,3-Butadiene	4/50
Acetonitrile	3/50
Allyl Glycidyl Ether	3/50
2-Chloroacetophenone	6/50
l-Epinephrine Hydrochloride	8/50
Chloroethane	1/50
Hexachlorocyclopentadiene	2/50
CS ₂ (o-Chlorobenzalmalononitrile)	3/50
Ozone	4/50
Overall Historical Incidence	
Total	58/950 (6.1%)
Standard deviation	3.8%
Range	2%-16%

^a Data as of 12 May 1995. Includes data for histiocytic, lymphocytic, mixed, NOS, and undifferentiated cell type lymphomas

TABLE C5
Summary of the Incidence of Nonneoplastic Lesions in Male Mice in the 2-Year Inhalation Study of Isobutyraldehyde^a

	Chamber Control	500 ppm	1,000 ppm	2,000 ppm
Disposition Summary				
Animals initially in study	50	50	50	50
Early deaths				
Moribund	6	8	6	15
Natural deaths	4	5	9	5
Survivors				
Terminal sacrifice	40	37	35	30
Animals examined microscopically	50	50	50	50
Alimentary System				
Gallbladder	(47)	(43)	(42)	(44)
Hyperplasia	1 (2%)	2 (5%)	2 (5%)	
Intestine large, cecum	(49)	(48)	(48)	(48)
Fibrosis		1 (2%)		
Parasite metazoan			1 (2%)	
Liver	(49)	(50)	(50)	(50)
Angiectasis		1 (2%)		
Basophilic focus	4 (8%)	8 (16%)	3 (6%)	4 (8%)
Clear cell focus	2 (4%)	7 (14%)	3 (6%)	2 (4%)
Cyst				1 (2%)
Degeneration, fatty			1 (2%)	
Eosinophilic focus	3 (6%)	6 (12%)	3 (6%)	3 (6%)
Infarct, focal	1 (2%)		2 (4%)	
Mixed cell focus		2 (4%)		1 (2%)
Necrosis	1 (2%)	1 (2%)	1 (2%)	2 (4%)
Tension lipidosis			1 (2%)	
Centrilobular, necrosis		1 (2%)	1 (2%)	
Mesentery	(1)	(3)	(5)	(3)
Artery, inflammation		1 (33%)		
Fat, necrosis	1 (100%)	2 (67%)	4 (80%)	2 (67%)
Pancreas	(50)	(49)	(50)	(50)
Atrophy	1 (2%)		1 (2%)	
Cyst				1 (2%)
Inflammation, chronic active	1 (2%)			1 (2%)
Lipomatosis	2 (4%)	2 (4%)	2 (4%)	5 (10%)
Necrosis	1 (2%)			
Stomach, forestomach	(50)	(50)	(50)	(50)
Diverticulum	1 (2%)			
Inflammation, chronic active	2 (4%)	2 (4%)	2 (4%)	1 (2%)
Stomach, glandular	(50)	(50)	(49)	(50)
Inflammation, chronic active		1 (2%)	2 (4%)	1 (2%)
Artery, inflammation			1 (2%)	
Tooth		(3)	(2)	
Developmental malformation		3 (100%)	1 (50%)	

^a Number of animals examined microscopically at the site and the number of animals with lesion

TABLE C5
Summary of the Incidence of Nonneoplastic Lesions in Male Mice in the 2-Year Inhalation Study of Isobutyraldehyde
 (continued)

	Chamber Control	500 ppm	1,000 ppm	2,000 ppm
Cardiovascular System				
Heart	(50)	(50)	(50)	(50)
Cardiomyopathy	26 (52%)	30 (60%)	26 (52%)	27 (54%)
Inflammation, suppurative				1 (2%)
Mineralization			1 (2%)	
Atrium, thrombosis			1 (2%)	
Endocrine System				
Arenal cortex	(50)	(50)	(50)	(50)
Atrophy	1 (2%)			
Hyperplasia	14 (28%)	21 (42%)	18 (36%)	18 (36%)
Hypertrophy	32 (64%)	21 (42%)	26 (52%)	26 (52%)
Adrenal medulla	(50)	(50)	(50)	(50)
Hyperplasia	1 (2%)		1 (2%)	
Pituitary gland	(49)	(47)	(49)	(49)
Cyst			1 (2%)	
Pars distalis, hyperplasia	3 (6%)	3 (6%)		
Pars intermedia, hyperplasia			1 (2%)	1 (2%)
Thyroid gland	(50)	(50)	(50)	(50)
Follicular cell, hyperplasia	11 (22%)	11 (22%)	14 (28%)	12 (24%)
General Body System				
None				
Genital System				
Epididymis	(50)	(50)	(50)	(50)
Granuloma sperm	1 (2%)			
Penis			(1)	(2)
Inflammation, chronic active				1 (50%)
Preputial gland	(50)	(50)	(49)	(50)
Cyst	7 (14%)	9 (18%)	6 (12%)	4 (8%)
Inflammation, chronic active	1 (2%)	2 (4%)	3 (6%)	5 (10%)
Prostate	(49)	(50)	(47)	(48)
Hyperplasia			1 (2%)	
Inflammation, chronic active	1 (2%)	1 (2%)	2 (4%)	
Seminal vesicle	(50)	(50)	(50)	(50)
Inflammation, acute	1 (2%)		1 (2%)	
Inflammation, chronic active	2 (4%)	1 (2%)		
Testes	(50)	(50)	(50)	(50)
Degeneration	1 (2%)			

TABLE C5
Summary of the Incidence of Nonneoplastic Lesions in Male Mice in the 2-Year Inhalation Study of Isobutyraldehyde
 (continued)

	Chamber Control	500 ppm	1,000 ppm	2,000 ppm
Hematopoietic System				
Lymph node				(4)
Iliac, infiltration cellular, plasma cell				1 (25%)
Lymph node, mesenteric	(50)	(48)	(47)	(47)
Angiectasis				1 (2%)
Spleen	(50)	(50)	(50)	(50)
Angiectasis			1 (2%)	
Hematopoietic cell proliferation	7 (14%)	7 (14%)	8 (16%)	9 (18%)
Hyperplasia, lymphoid	1 (2%)	1 (2%)		1 (2%)
Thymus	(39)	(39)	(42)	(36)
Artery, inflammation			1 (2%)	
Integumentary System				
Skin	(49)	(50)	(50)	(50)
Inflammation, chronic active	1 (2%)	2 (4%)	2 (4%)	
Necrosis		1 (2%)		
Prepuce, inflammation, acute	3 (6%)	4 (8%)	4 (8%)	9 (18%)
Subcutaneous tissue, edema			1 (2%)	
Musculoskeletal System				
None				
Nervous System				
Brain	(50)	(50)	(50)	(50)
Cyst epithelial inclusion				1 (2%)
Respiratory System				
Larynx	(50)	(49)	(50)	(50)
Inflammation, suppurative		1 (2%)		
Epiglottis, hyperplasia	1 (2%)		1 (2%)	
Epiglottis, metaplasia, squamous	1 (2%)	1 (2%)	1 (2%)	3 (6%)
Glands, inflammation, suppurative		1 (2%)	1 (2%)	3 (6%)
Lung	(50)	(50)	(50)	(50)
Inflammation, suppurative		1 (2%)		
Mineralization	1 (2%)			
Pigmentation	1 (2%)			
Alveolar epithelium, hyperplasia	3 (6%)	3 (6%)	3 (6%)	2 (4%)
Alveolus, infiltration cellular, histiocyte			1 (2%)	
Artery, mediastinum, mineralization	1 (2%)	1 (2%)		
Bronchiole, hyperplasia	2 (4%)			
Nose	(50)	(50)	(50)	(50)
Inflammation, suppurative		2 (4%)	1 (2%)	3 (6%)
Nasolacrimal duct, hyperplasia	1 (2%)			
Nasolacrimal duct, inflammation, suppurative	1 (2%)			
Olfactory epithelium, degeneration			11 (22%)	45 (90%)
Olfactory epithelium, necrosis				1 (2%)
Trachea	(50)	(50)	(50)	(50)
Inflammation, suppurative		1 (2%)		

TABLE C5**Summary of the Incidence of Nonneoplastic Lesions in Male Mice in the 2-Year Inhalation Study of Isobutyraldehyde**
(continued)

	Chamber Control	500 ppm	1,000 ppm	2,000 ppm
Special Senses System				
Eye			(1)	
Cornea, inflammation, chronic active			1 (100%)	
Urinary System				
Kidney	(50)	(50)	(50)	(50)
Cyst	3 (6%)	3 (6%)	1 (2%)	1 (2%)
Infarct	2 (4%)	1 (2%)	1 (2%)	5 (10%)
Mineralization	1 (2%)	1 (2%)	1 (2%)	1 (2%)
Necrosis				1 (2%)
Nephropathy	45 (90%)	46 (92%)	44 (88%)	45 (90%)
Artery, inflammation				2 (4%)
Pelvis, dilatation			1 (2%)	
Pelvis, inflammation, acute	2 (4%)	1 (2%)	2 (4%)	2 (4%)
Transitional epithelium, hyperplasia			1 (2%)	
Urinary bladder	(50)	(50)	(48)	(50)
Inflammation, acute				1 (2%)
Inflammation, chronic active	1 (2%)		2 (4%)	3 (6%)
Mineralization	1 (2%)			
Artery, inflammation			1 (2%)	
Transitional epithelium, hyperplasia	1 (2%)			1 (2%)

APPENDIX D
SUMMARY OF LESIONS IN FEMALE MICE
IN THE 2-YEAR INHALATION STUDY
OF ISOBUTYRALDEHYDE

TABLE D1	Summary of the Incidence of Neoplasms in Female Mice in the 2-Year Inhalation Study of Isobutyraldehyde	152
TABLE D2	Individual Animal Tumor Pathology of Female Mice in the 2-Year Inhalation Study of Isobutyraldehyde	156
TABLE D3	Statistical Analysis of Primary Neoplasms in Female Mice in the 2-Year Inhalation Study of Isobutyraldehyde	176
TABLE D4a	Historical Incidence of Malignant Lymphoma in Chamber Control Female B6C3F₁ Mice	181
TABLE D4b	Historical Incidence of Ovarian Neoplasms in Chamber Control Female B6C3F₁ Mice	181
TABLE D5	Summary of the Incidence of Nonneoplastic Lesions in Female Mice in the 2-Year Inhalation Study of Isobutyraldehyde	182

TABLE D1
Summary of the Incidence of Neoplasms in Female Mice in the 2-Year Inhalation Study of Isobutyraldehyde^a

	Chamber Control	500 ppm	1,000 ppm	2,000 ppm
Disposition Summary				
Animals initially in study	50	50	50	50
Early deaths				
Accidental deaths	1	1		
Moribund	16	13	10	11
Natural deaths	5	4	4	2
Survivors				
Died last week of study			1	
Terminal sacrifice	28	32	35	37
Animals examined microscopically	50	50	50	50
Alimentary System				
Gallbladder	(46)	(44)	(45)	(47)
Intestine large, rectum	(50)	(49)	(49)	(49)
Intestine large, cecum	(49)	(46)	(49)	(50)
Leiomyoma		1 (2%)		
Intestine small, duodenum	(47)	(45)	(47)	(48)
Polyp adenomatous		1 (2%)		
Intestine small, jejunum	(47)	(46)	(48)	(49)
Carcinoma			1 (2%)	
Intestine small, ileum	(49)	(46)	(47)	(49)
Liver	(49)	(49)	(50)	(50)
Hemangiosarcoma	1 (2%)	1 (2%)		
Hepatocellular carcinoma	6 (12%)	8 (16%)	4 (8%)	3 (6%)
Hepatocellular carcinoma, multiple		1 (2%)		
Hepatocellular adenoma	6 (12%)	12 (24%)	9 (18%)	8 (16%)
Hepatocellular adenoma, multiple	3 (6%)		2 (4%)	1 (2%)
Hepatocholangiocarcinoma	2 (4%)	1 (2%)		
Histiocytic sarcoma	1 (2%)		1 (2%)	
Mesentery	(8)	(2)	(4)	(3)
Hemangiosarcoma	1 (13%)			
Hepatocholangiocarcinoma, metastatic, liver	2 (25%)			
Histiocytic sarcoma			1 (25%)	
Leiomyosarcoma, metastatic, uterus			1 (25%)	
Pancreas	(50)	(49)	(50)	(50)
Carcinoma			1 (2%)	
Hemangiosarcoma			1 (2%)	
Hepatocholangiocarcinoma, metastatic, liver	1 (2%)			
Histiocytic sarcoma	1 (2%)		1 (2%)	
Salivary glands	(50)	(50)	(49)	(50)
Stomach, forestomach	(50)	(50)	(50)	(50)
Hepatocholangiocarcinoma, metastatic, liver	1 (2%)			
Histiocytic sarcoma	1 (2%)		1 (2%)	
Squamous cell papilloma			3 (6%)	1 (2%)
Stomach, glandular	(49)	(49)	(50)	(50)
Histiocytic sarcoma	1 (2%)			
Tongue			(1)	
Squamous cell carcinoma			1 (100%)	

TABLE D1
Summary of the Incidence of Neoplasms in Female Mice in the 2-Year Inhalation Study of Isobutyraldehyde (continued)

	Chamber Control	500 ppm	1,000 ppm	2,000 ppm
Cardiovascular System				
Heart	(50)	(50)	(50)	(50)
Histiocytic sarcoma	1 (2%)			
Endocrine System				
Adrenal cortex	(50)	(49)	(50)	(50)
Adenoma		1 (2%)		
Hepatocellular carcinoma, metastatic, liver				1 (2%)
Hepatocholangiocarcinoma, metastatic, liver	1 (2%)			
Histiocytic sarcoma			1 (2%)	
Capsule, adenoma		1 (2%)		
Adrenal medulla	(50)	(49)	(50)	(50)
Pheochromocytoma malignant				1 (2%)
Pheochromocytoma benign	1 (2%)	2 (4%)		
Islets, pancreatic	(50)	(49)	(50)	(50)
Adenoma	1 (2%)	1 (2%)	1 (2%)	
Carcinoma			2 (4%)	
Pituitary gland	(50)	(49)	(50)	(49)
Pars distalis, adenoma	10 (20%)	9 (18%)	6 (12%)	9 (18%)
Pars intermedia, adenoma			1 (2%)	1 (2%)
Thyroid gland	(50)	(50)	(50)	(50)
Follicular cell, adenoma	3 (6%)	1 (2%)	2 (4%)	1 (2%)
General Body System				
None				
Genital System				
Ovary	(50)	(49)	(50)	(50)
Choriocarcinoma		1 (2%)		
Cystadenocarcinoma		2 (4%)		
Cystadenoma	1 (2%)	5 (10%)		2 (4%)
Hemangiosarcoma				1 (2%)
Histiocytic sarcoma	1 (2%)		1 (2%)	
Luteoma		1 (2%)	1 (2%)	1 (2%)
Teratoma benign	1 (2%)			
Teratoma malignant	1 (2%)			
Tubulostromal adenoma	1 (2%)			
Yolk sac carcinoma	1 (2%)			
Bilateral, cystadenoma			1 (2%)	
Uterus	(50)	(50)	(50)	(50)
Histiocytic sarcoma	1 (2%)		2 (4%)	
Leiomyosarcoma			1 (2%)	
Polyp stromal	2 (4%)	2 (4%)	1 (2%)	5 (10%)

TABLE D1
Summary of the Incidence of Neoplasms in Female Mice in the 2-Year Inhalation Study of Isobutyraldehyde (continued)

	Chamber Control	500 ppm	1,000 ppm	2,000 ppm
Hematopoietic System				
Bone marrow	(50)	(50)	(50)	(50)
Hemangiosarcoma		1 (2%)	1 (2%)	
Histiocytic sarcoma	1 (2%)			
Lymph node	(5)	(5)	(4)	(4)
Iliac, histiocytic sarcoma	1 (20%)		1 (25%)	
Renal, hemangiosarcoma		1 (20%)		
Renal, histiocytic sarcoma	1 (20%)			
Lymph node, bronchial	(42)	(38)	(42)	(44)
Lymph node, mandibular	(38)	(38)	(44)	(45)
Histiocytic sarcoma	1 (3%)			
Lymph node, mesenteric	(48)	(49)	(47)	(47)
Hepatocolangiocarcinoma, metastatic, liver	1 (2%)			
Histiocytic sarcoma	1 (2%)			
Lymph node, mediastinal	(38)	(38)	(38)	(38)
Hepatocolangiocarcinoma, metastatic, liver	2 (5%)			
Histiocytic sarcoma	1 (3%)			
Spleen	(50)	(49)	(50)	(50)
Hemangiosarcoma		1 (2%)	1 (2%)	
Hepatocolangiocarcinoma, metastatic, liver	2 (4%)			
Thymus	(41)	(43)	(41)	(43)
Histiocytic sarcoma	1 (2%)			
Integumentary System				
Mammary gland	(49)	(50)	(50)	(50)
Carcinoma	1 (2%)	1 (2%)	2 (4%)	
Skin	(50)	(50)	(50)	(50)
Squamous cell carcinoma				1 (2%)
Subcutaneous tissue, fibrosarcoma		1 (2%)		2 (4%)
Subcutaneous tissue, hemangiosarcoma		2 (4%)	1 (2%)	
Subcutaneous tissue, histiocytic sarcoma			1 (2%)	1 (2%)
Musculoskeletal System				
Skeletal muscle		(1)	(1)	
Fibrosarcoma			1 (100%)	
Nervous System				
Brain	(50)	(50)	(50)	(50)
Histiocytic sarcoma	1 (2%)			

TABLE D1
Summary of the Incidence of Neoplasms in Female Mice in the 2-Year Inhalation Study of Isobutylaldehyde (continued)

	Chamber Control	500 ppm	1,000 ppm	2,000 ppm
Respiratory System				
Larynx	(50)	(50)	(49)	(50)
Lung	(50)	(50)	(50)	(50)
Alveolar/bronchiolar adenoma		1 (2%)	1 (2%)	3 (6%)
Alveolar/bronchiolar carcinoma	3 (6%)		2 (4%)	1 (2%)
Carcinoma, metastatic, harderian gland			1 (2%)	
Carcinoma, metastatic, mammary gland		1 (2%)	1 (2%)	
Hepatocellular carcinoma, metastatic, liver	2 (4%)	2 (4%)	1 (2%)	1 (2%)
Hepatocholangiocarcinoma, metastatic, liver	2 (4%)	1 (2%)		
Histiocytic sarcoma	1 (2%)		1 (2%)	
Squamous cell carcinoma, metastatic, skin				1 (2%)
Mediastinum, hepatocholangiocarcinoma, metastatic, liver	1 (2%)			
Nose	(50)	(50)	(50)	(50)
Hemangioma			1 (2%)	
Histiocytic sarcoma	1 (2%)		1 (2%)	
Special Senses System				
Harderian gland	(3)	(4)	(2)	(2)
Adenoma	1 (33%)	4 (100%)	1 (50%)	1 (50%)
Carcinoma	1 (33%)		1 (50%)	
Urinary System				
Kidney	(50)	(50)	(50)	(50)
Hepatocholangiocarcinoma, metastatic, liver	1 (2%)			
Histiocytic sarcoma	1 (2%)			
Ureter			(1)	
Transitional epithelium, papilloma			1 (100%)	
Urinary bladder	(49)	(49)	(50)	(50)
Histiocytic sarcoma	1 (2%)		1 (2%)	
Leiomyosarcoma, metastatic, uterus			1 (2%)	
Systemic Lesions				
Multiple organs ^b	(50)	(50)	(50)	(50)
Histiocytic sarcoma	1 (2%)		3 (6%)	1 (2%)
Lymphoma malignant	12 (24%)	13 (26%)	12 (24%)	19 (38%)
Neoplasm Summary				
Total animals with primary neoplasms ^c	38	45	37	40
Total primary neoplasms	60	76	66	62
Total animals with benign neoplasms	26	34	26	25
Total benign neoplasms	30	42	31	33
Total animals with malignant neoplasms	25	28	26	24
Total malignant neoplasms	30	34	35	29
Total animals with metastatic neoplasms	4	4	3	2
Total metastatic neoplasms	16	4	5	3

^a Number of animals examined microscopically at the site and the number of animals with neoplasm

^b Number of animals with any tissue examined microscopically

^c Primary neoplasms: all neoplasms except metastatic neoplasms

TABLE D2
Individual Animal Tumor Pathology of Female Mice in the 2-Year Inhalation Study of Isobutyraldehyde:
Chamber Control

Number of Days on Study	0	0	3	5	5	5	5	6	6	6	6	6	6	6	6	6	6	7	7	7	7	7	7	7	7
Carcass ID Number	1	1	1	1	1	1	1	1	1	1	1	1	1	1	1	1	1	1	1	1	1	1	1	1	1
	6	7	4	3	4	8	9	1	2	3	3	4	4	5	8	9	9	0	0	0	1	2	3	3	3
	9	6	4	3	3	3	6	1	3	7	9	6	6	7	6	1	5	0	1	1	2	3	5	5	5
Alimentary System																									
Esophagus	+	+	+	+	+	+	+	+	+	+	+	+	+	+	+	+	+	+	+	+	+	+	+	+	+
Gallbladder	+	+	+	+	A	+	+	+	+	+	+	+	+	+	+	A	+	+	+	+	+	+	+	+	+
Intestine large, colon	+	+	+	+	+	+	+	+	+	+	+	+	+	+	+	A	+	+	+	+	+	+	+	+	+
Intestine large, rectum	+	+	+	+	+	+	+	+	+	+	+	+	+	+	+	+	+	+	+	+	+	+	+	+	+
Intestine large, cecum	+	+	+	+	+	+	+	+	+	+	+	+	+	+	+	A	+	+	+	+	+	+	+	+	+
Intestine small, duodenum	+	+	+	+	A	+	A	+	+	+	+	+	+	+	+	A	+	+	+	+	+	+	+	+	+
Intestine small, jejunum	+	+	+	+	+	A	+	+	A	+	+	+	+	+	+	A	+	+	+	+	+	+	+	+	+
Intestine small, ileum	+	+	+	+	+	+	+	+	+	+	+	+	+	+	+	A	+	+	+	+	+	+	+	+	+
Liver	+	+	+	+	+	+	+	+	+	+	+	+	+	+	+	A	+	+	+	+	+	+	+	+	+
Hemangiosarcoma																									X
Hepatocellular carcinoma					X	X			X																X
Hepatocellular adenoma						X						X				X									
Hepatocellular adenoma, multiple																	X								X
Hepatocholangiocarcinoma							X					X													
Histiocytic sarcoma																									
Mesentery							+				+					+							+	+	
Hemangiosarcoma																									X
Hepatocholangiocarcinoma, metastatic, liver							X					X													
Pancreas	+	+	+	+	+	+	+	+	+	+	+	+	+	+	+	+	+	+	+	+	+	+	+	+	+
Hepatocholangiocarcinoma, metastatic, liver							X																		
Histiocytic sarcoma																									
Salivary glands	+	+	+	+	+	+	+	+	+	+	+	+	+	+	+	+	+	+	+	+	+	+	+	+	+
Stomach, forestomach	+	+	+	+	+	+	+	+	+	+	+	+	+	+	+	+	+	+	+	+	+	+	+	+	+
Hepatocholangiocarcinoma, metastatic, liver							X																		
Histiocytic sarcoma																									
Stomach, glandular	+	+	+	+	+	+	+	+	+	+	+	+	+	+	+	A	+	+	+	+	+	+	+	+	+
Histiocytic sarcoma																									
Cardiovascular System																									
Heart	+	+	+	+	+	+	+	+	+	+	+	+	+	+	+	+	+	+	+	+	+	+	+	+	+
Histiocytic sarcoma																									
Endocrine System																									
Adrenal cortex	+	+	+	+	+	+	+	+	+	+	+	+	+	+	+	+	+	+	+	+	+	+	+	+	+
Hepatocholangiocarcinoma, metastatic, liver							X																		
Adrenal medulla	+	+	+	+	+	+	+	+	+	+	+	+	+	+	+	+	+	+	+	+	+	+	+	+	+
Pheochromocytoma benign																									
Islets, pancreatic	+	+	+	+	+	+	+	+	+	+	+	+	+	+	+	+	+	+	+	+	+	+	+	+	+
Adenoma												X													
Parathyroid gland	+	+	+	M	+	+	+	+	+	+	+	+	+	+	+	M	+	+	+	+	+	+	+	+	M
Pituitary gland	+	+	+	+	+	+	+	+	+	+	+	+	+	+	+	+	+	+	+	+	+	+	+	+	+
Pars distalis, adenoma					X							X		X											
Thyroid gland	+	+	+	+	+	+	+	+	+	+	+	+	+	+	+	+	+	+	+	+	+	+	+	+	+
Follicular cell, adenoma																									

+: Tissue examined microscopically
A: Autolysis precludes examination
M: Missing tissue
I: Insufficient tissue
X: Lesion present
Blank: Not examined

TABLE D2
Individual Animal Tumor Pathology of Female mice in the 2-Year Inhalation Study of Isobutyraldehyde:
Chamber Control (continued)

Number of Days on Study	7 7 7 7 7 7 7 7 7 7 7 7 7 7 7 7 7 7 7 7 7 7 7 7	
	3 3 3 3 3 3 3 3 3 3 3 3 3 3 3 3 3 3 3 3 3 3 3 3	
	5 5 5 5 5 6 6 6 6 6 6 6 6 6 6 6 7 7 7 7 7 7 7 7	
Carcass ID Number	1 1 1 1 1 1 1 1 1 1 1 1 1 1 1 1 1 1 1 1 1 1 1 1	Total
	2 2 2 3 4 0 0 0 0 0 2 4 4 4 4 4 1 1 1 2 2 3 3 3 4	Tissues/
	5 8 9 0 0 1 2 4 5 6 7 1 2 3 6 7 4 6 9 1 2 5 6 7 4	Tumors
General Body System		
None		
Genital System		
Clitoral gland	M + + + + + + + + + M + + + + + + + M + + + + +	44
Ovary	+ + + + + + + + + + + + + + + + + + + + + + + + +	50
Cystadenoma		1
Histiocytic sarcoma		1
Teratoma benign		1
Teratoma malignant		1
Tubulostromal adenoma		1
Yolk sac carcinoma		1
Uterus	+ + + + + + + + + + + + + + + + + + + + + + + + +	50
Histiocytic sarcoma		1
Polyp stromal		2
Hematopoietic System		
Bone marrow	+ + + + + + + + + + + + + + + + + + + + + + + + +	50
Histiocytic sarcoma		1
Lymph node	+ + + + + + + + + + + + + + + + + + + + + + + + +	5
Iliac, histiocytic sarcoma		1
Renal, histiocytic sarcoma		1
Lymph node, bronchial	+ + + + M + + + + + M + + + + + + + M M M + + + + +	42
Lymph node, mandibular	+ + + M + M + + + + M M + + + + M M + + M M + + + +	38
Histiocytic sarcoma		1
Lymph node, mesenteric	+ + + + + + + + + + + + + + + + + + + + + + + + +	48
Hepatocholangiocarcinoma, metastatic, liver		1
Histiocytic sarcoma		1
Lymph node, mediastinal	+ + + + + + + + + + + + + + + + M + + + M + + + M + + + +	38
Hepatocholangiocarcinoma, metastatic, liver		2
Histiocytic sarcoma		1
Spleen	+ + + + + + + + + + + + + + + + + + + + + + + + +	50
Hepatocholangiocarcinoma, metastatic, liver		2
Thymus	+ + + + M + + + + + M + + + + + + + + + + + + + + + +	41
Histiocytic sarcoma		1
Integumentary System		
Mammary gland	+ + + + + + + + + + + + + + + + M + + + + + + + + + + +	49
Carcinoma		1
Skin	+ + + + + + + + + + + + + + + + + + + + + + + + +	50
Musculoskeletal System		
Bone	+ + + + + + + + + + + + + + + + + + + + + + + + +	50
Nervous System		
Brain	+ + + + + + + + + + + + + + + + + + + + + + + + +	50
Histiocytic sarcoma		1

TABLE D2
Individual Animal Tumor Pathology of Female Mice in the 2-Year Inhalation Study of Isobutyraldehyde:
Chamber Control (continued)

Number of Days on Study	0 0 3 5 5 5 5 6 6 6 6 6 6 6 6 6 6 6 7 7 7 7 7 7 7 7
	6 7 4 3 4 8 9 1 2 3 3 4 4 5 8 9 9 0 0 0 1 2 3 3 3
	9 6 4 3 3 3 6 1 3 7 9 6 6 7 6 1 5 0 1 1 2 3 5 5 5
Carcass ID Number	1 1 1 1 1 1 1 1 1 1 1 1 1 1 1 1 1 1 1 1 1 1 1 1 1
	2 1 4 3 3 2 0 4 1 2 3 1 1 3 3 1 4 3 0 0 5 1 0 1 2
	0 8 9 4 8 4 8 5 1 6 3 0 2 2 9 5 8 1 3 7 0 7 9 3 3
Respiratory System	
Larynx	+ + + + + + + + + + + + + + + + + + + + + + + + +
Lung	+ + + + + + + + + + + + + + + + + + + + + + + + +
Alveolar/bronchiolar carcinoma	X
Hepatocellular carcinoma, metastatic, liver	X
Hepatocholangiocarcinoma, metastatic, liver	X
Histiocytic sarcoma	
Mediastinum, hepatocholangiocarcinoma, metastatic, liver	X
Nose	+ + + + + + + + + + + + + + + + + + + + + + + + +
Histiocytic sarcoma	
Trachea	+ + + + + + + + + + + + + + + + + + + + + + + + +
Special Senses System	
Harderian gland	+
Adenoma	
Carcinoma	
Urinary System	
Kidney	+ + + + + + + + + + + + + + + + + + + + + + + + +
Hepatocholangiocarcinoma, metastatic, liver	X
Histiocytic sarcoma	
Urinary bladder	+ M + + + + + + + + + + + + + + + + + + + + + + +
Histiocytic sarcoma	
Systemic Lesions	
Multiple organs	+ + + + + + + + + + + + + + + + + + + + + + + + +
Histiocytic sarcoma	
Lymphoma malignant	X X X X

TABLE D2
Individual Animal Tumor Pathology of Female Mice in the 2-Year Inhalation Study of Isobutyraldehyde: 1,000 ppm
 (continued)

Number of Days on Study	7 7 7 7 7 7 7 7 7 7 7 7 7 7 7 7 7 7 7 7 7 7 7 7	
	3 3 3 3 3 3 3 3 3 3 3 3 3 3 3 3 3 3 3 3 3 3 3 3	
	6 6 6 6 6 6 6 6 6 6 6 6 6 6 6 7 7 7 7 7 7 7 7 7	
Carcass ID Number	5 5 5 5 5 5 5 5 5 5 5 5 5 5 5 5 5 5 5 5 5 5 5 5	Total
	1 1 1 1 2 2 2 2 3 3 3 3 4 4 4 0 1 1 2 2 3 3 3 4 5	Tissues/
	1 2 4 5 1 3 8 9 6 7 8 9 3 5 8 2 3 6 6 7 3 4 5 0 0	Tumors
Special Senses System		
Harderian gland		2
Adenoma	X	1
Carcinoma		1
Urinary System		
Kidney	+ + + + + + + + + + + + + + + + + + + + + + +	50
Ureter		1
Transitional epithelium, papilloma		1
Urinary bladder	+ + + + + + + + + + + + + + + + + + + + + + +	50
Histiocytic sarcoma		1
Leiomyosarcoma, metastatic, uterus		1
Systemic Lesions		
Multiple organs	+ + + + + + + + + + + + + + + + + + + + + + +	50
Histiocytic sarcoma	X	3
Lymphoma malignant	X X X X X X X X	12

TABLE D3
Statistical Analysis of Primary Neoplasms in Female Mice in the 2-Year Inhalation Study of Isobutyraldehyde

	Chamber Control	500 ppm	1,000 ppm	2,000 ppm
Harderian Gland: Adenoma				
Overall rate ^a	1/50 (2%)	4/50 (8%)	1/50 (2%)	1/50 (2%)
Adjusted rate ^b	3.6%	11.2%	2.8%	2.7%
Terminal rate ^c	1/28 (4%)	2/32 (6%)	1/36 (3%)	1/37 (3%)
First incidence (days)	735 (T)	686	735 (T)	735 (T)
Life table test ^d	P= 0.300N	P= 0.215	P= 0.705N	P= 0.699N
Logistic regression test ^d	P= 0.333N	P= 0.197	P= 0.705N	P= 0.699N
Cochran-Armitage test ^d	P= 0.373N			
Fisher exact test ^d		P= 0.181	P= 0.753N	P= 0.753N
Harderian Gland: Adenoma or Carcinoma				
Overall rate	2/50 (4%)	4/50 (8%)	2/50 (4%)	1/50 (2%)
Adjusted rate	7.1%	11.2%	5.6%	2.7%
Terminal rate	2/28 (7%)	2/32 (6%)	2/36 (6%)	1/37 (3%)
First incidence (days)	735 (T)	686	735 (T)	735 (T)
Life table test	P= 0.190N	P= 0.389	P= 0.602N	P= 0.403N
Logistic regression test	P= 0.219N	P= 0.367	P= 0.602N	P= 0.402N
Cochran-Armitage test	P= 0.263N			
Fisher exact test		P= 0.339	P= 0.691N	P= 0.500N
Liver: Hepatocellular Adenoma				
Overall rate	9/49 (18%)	12/49 (24%)	11/50 (22%)	9/50 (18%)
Adjusted rate	26.3%	33.5%	28.4%	22.4%
Terminal rate	5/28 (18%)	9/32 (28%)	9/36 (25%)	7/37 (19%)
First incidence (days)	583	636	581	611
Life table test	P= 0.254N	P= 0.416	P= 0.585	P= 0.396N
Logistic regression test	P= 0.379N	P= 0.359	P= 0.476	P= 0.534N
Cochran-Armitage test	P= 0.440N			
Fisher exact test		P= 0.312	P= 0.421	P= 0.584N
Liver: Hepatocellular Carcinoma				
Overall rate	6/49 (12%)	9/49 (18%)	4/50 (8%)	3/50 (6%)
Adjusted rate	16.7%	21.6%	10.8%	7.8%
Terminal rate	3/28 (11%)	2/32 (6%)	3/36 (8%)	2/37 (5%)
First incidence (days)	543	527	713	682
Life table test	P= 0.060N	P= 0.361	P= 0.268N	P= 0.168N
Logistic regression test	P= 0.097N	P= 0.265	P= 0.349N	P= 0.236N
Cochran-Armitage test	P= 0.090N			
Fisher exact test		P= 0.288	P= 0.357N	P= 0.233N
Liver: Hepatocellular Adenoma or Carcinoma				
Overall rate	12/49 (24%)	20/49 (41%)	15/50 (30%)	12/50 (24%)
Adjusted rate	32.8%	47.8%	38.1%	29.4%
Terminal rate	6/28 (21%)	11/32 (34%)	12/36 (33%)	9/37 (24%)
First incidence (days)	543	527	581	611
Life table test	P= 0.143N	P= 0.149	P= 0.546	P= 0.364N
Logistic regression test	P= 0.263N	P= 0.072	P= 0.401	P= 0.530N
Cochran-Armitage test	P= 0.300N			
Fisher exact test		P= 0.065	P= 0.349	P= 0.570N

TABLE D3
Statistical Analysis of Primary Neoplasms in Female Mice in the 2-Year Inhalation Study of Isobutyraldehyde (continued)

	Chamber Control	500 ppm	1,000 ppm	2,000 ppm
Lung: Alveolar/bronchiolar Adenoma				
Overall rate	0/50 (0%)	1/50 (2%)	1/50 (2%)	3/50 (6%)
Adjusted rate	0.0%	3.1%	2.4%	8.1%
Terminal rate	0/28 (0%)	1/32 (3%)	0/36 (0%)	3/37 (8%)
First incidence (days)	— ^e	735 (T)	645	735 (T)
Life table test	P= 0.082	P= 0.527	P= 0.510	P= 0.174
Logistic regression test	P= 0.062	P= 0.527	P= 0.475	P= 0.172
Cochran-Armitage test	P= 0.054			
Fisher exact test		P= 0.500	P= 0.500	P= 0.121
Lung: Alveolar/bronchiolar Carcinoma				
Overall rate	3/50 (6%)	0/50 (0%)	2/50 (4%)	1/50 (2%)
Adjusted rate	9.2%	0.0%	5.6%	2.7%
Terminal rate	2/28 (7%)	0/32 (0%)	2/36 (6%)	1/37 (3%)
First incidence (days)	543	—	735 (T)	735 (T)
Life table test	P= 0.266N	P= 0.105N	P= 0.404N	P= 0.234N
Logistic regression test	P= 0.324N	P= 0.122N	P= 0.485N	P= 0.301N
Cochran-Armitage test	P= 0.337N			
Fisher exact test		P= 0.121N	P= 0.500N	P= 0.309N
Lung: Alveolar/bronchiolar Adenoma or Carcinoma				
Overall rate	3/50 (6%)	1/50 (2%)	3/50 (6%)	4/50 (8%)
Adjusted rate	9.2%	3.1%	7.9%	10.8%
Terminal rate	2/28 (7%)	1/32 (3%)	2/36 (6%)	4/37 (11%)
First incidence (days)	543	735 (T)	645	735 (T)
Life table test	P= 0.389	P= 0.268N	P= 0.573N	P= 0.630
Logistic regression test	P= 0.306	P= 0.300N	P= 0.661N	P= 0.533
Cochran-Armitage test	P= 0.282			
Fisher exact test		P= 0.309N	P= 0.661N	P= 0.500
Ovary: Cystadenoma				
Overall rate	1/50 (2%)	5/49 (10%)	1/50 (2%)	2/50 (4%)
Adjusted rate	3.6%	14.6%	2.8%	4.9%
Terminal rate	1/28 (4%)	4/32 (13%)	1/36 (3%)	1/37 (3%)
First incidence (days)	735 (T)	623	735 (T)	653
Life table test	P= 0.417N	P= 0.131	P= 0.705N	P= 0.587
Logistic regression test	P= 0.489N	P= 0.113	P= 0.705N	P= 0.522
Cochran-Armitage test	P= 0.520N			
Fisher exact test		P= 0.098	P= 0.753N	P= 0.500
Ovary: Cystadenoma or Cystadenocarcinoma				
Overall rate	1/50 (2%)	7/49 (14%)	1/50 (2%)	2/50 (4%)
Adjusted rate	3.6%	20.7%	2.8%	4.9%
Terminal rate	1/28 (4%)	6/32 (19%)	1/36 (3%)	1/37 (3%)
First incidence (days)	735 (T)	623	735 (T)	653
Life table test	P= 0.286N	P= 0.046	P= 0.705N	P= 0.587
Logistic regression test	P= 0.353N	P= 0.038	P= 0.705N	P= 0.522
Cochran-Armitage test	P= 0.393N			
Fisher exact test		P= 0.028	P= 0.753N	P= 0.500

TABLE D3
Statistical Analysis of Primary Neoplasms in Female Mice in the 2-Year Inhalation Study of Isobutyraldehyde (continued)

	Chamber Control	500 ppm	1,000 ppm	2,000 ppm
Pancreatic Islets: Adenoma or Carcinoma				
Overall rate	1/50 (2%)	1/49 (2%)	3/50 (6%)	0/50 (0%)
Adjusted rate	2.5%	3.0%	7.3%	0.0%
Terminal rate	0/28 (0%)	0/32 (0%)	1/36 (3%)	0/37 (0%)
First incidence (days)	639	731	631	—
Life table test	P= 0.354N	P= 0.742N	P= 0.339	P= 0.472N
Logistic regression test	P= 0.424N	P= 0.761	P= 0.273	P= 0.526N
Cochran-Armitage test	P= 0.407N			
Fisher exact test		P= 0.747	P= 0.309	P= 0.500N
Pituitary Gland (Pars Distalis): Adenoma				
Overall rate	10/50 (20%)	9/49 (18%)	6/50 (12%)	9/49 (18%)
Adjusted rate	30.5%	27.7%	15.8%	24.0%
Terminal rate	7/28 (25%)	8/31 (26%)	4/36 (11%)	8/36 (22%)
First incidence (days)	533	681	674	653
Life table test	P= 0.240N	P= 0.414N	P= 0.111N	P= 0.298N
Logistic regression test	P= 0.354N	P= 0.468N	P= 0.169N	P= 0.447N
Cochran-Armitage test	P= 0.437N			
Fisher exact test		P= 0.520N	P= 0.207N	P= 0.520N
Stomach (Forestomach): Squamous Cell Papilloma				
Overall rate	0/50 (0%)	0/50 (0%)	3/50 (6%)	1/50 (2%)
Adjusted rate	0.0%	0.0%	8.3%	2.7%
Terminal rate	0/28 (0%)	0/32 (0%)	3/36 (8%)	1/37 (3%)
First incidence (days)	—	—	735 (T)	735 (T)
Life table test	P= 0.313	— ^f	P= 0.168	P= 0.556
Logistic regression test	P= 0.313	—	P= 0.168	P= 0.556
Cochran-Armitage test	P= 0.247			
Fisher exact test		—	P= 0.121	P= 0.500
Thyroid Gland (Follicular Cell): Adenoma				
Overall rate	3/50 (6%)	1/50 (2%)	2/50 (4%)	1/50 (2%)
Adjusted rate	10.7%	3.1%	5.6%	2.7%
Terminal rate	3/28 (11%)	1/32 (3%)	2/36 (6%)	1/37 (3%)
First incidence (days)	735 (T)	735 (T)	735 (T)	735 (T)
Life table test	P= 0.197N	P= 0.257N	P= 0.385N	P= 0.211N
Logistic regression test	P= 0.197N	P= 0.257N	P= 0.385N	P= 0.211N
Cochran-Armitage test	P= 0.279N			
Fisher exact test		P= 0.309N	P= 0.500N	P= 0.309N
Uterus: Stromal Polyp				
Overall rate	2/50 (4%)	2/50 (4%)	1/50 (2%)	5/50 (10%)
Adjusted rate	5.6%	6.3%	2.8%	13.5%
Terminal rate	1/28 (4%)	2/32 (6%)	1/36 (3%)	5/37 (14%)
First incidence (days)	344	735 (T)	735 (T)	735 (T)
Life table test	P= 0.179	P= 0.656N	P= 0.437N	P= 0.325
Logistic regression test	P= 0.116	P= 0.674	P= 0.592N	P= 0.207
Cochran-Armitage test	P= 0.114			
Fisher exact test		P= 0.691N	P= 0.500N	P= 0.218

TABLE D3
Statistical Analysis of Primary Neoplasms in Female Mice in the 2-Year Inhalation Study of Isobutyraldehyde (continued)

	Chamber Control	500 ppm	1,000 ppm	2,000 ppm
All Organs: Hemangiosarcoma				
Overall rate	2/50 (4%)	4/50 (8%)	4/50 (8%)	1/50 (2%)
Adjusted rate	7.1%	9.9%	11.1%	2.6%
Terminal rate	2/28 (7%)	0/32 (0%)	4/36 (11%)	0/37 (0%)
First incidence (days)	735 (T)	595	735 (T)	702
Life table test	P= 0.233N	P= 0.388	P= 0.457	P= 0.409N
Logistic regression test	P= 0.300N	P= 0.339	P= 0.457	P= 0.454N
Cochran-Armitage test	P= 0.319N			
Fisher exact test		P= 0.339	P= 0.339	P= 0.500N
All Organs: Hemangioma or Hemangiosarcoma				
Overall rate	2/50 (4%)	4/50 (8%)	5/50 (10%)	1/50 (2%)
Adjusted rate	7.1%	9.9%	13.3%	2.6%
Terminal rate	2/28 (7%)	0/32 (0%)	4/36 (11%)	0/37 (0%)
First incidence (days)	735 (T)	595	653	702
Life table test	P= 0.253N	P= 0.388	P= 0.317	P= 0.409N
Logistic regression test	P= 0.329N	P= 0.339	P= 0.256	P= 0.454N
Cochran-Armitage test	P= 0.344N			
Fisher exact test		P= 0.339	P= 0.218	P= 0.500N
All Organs: Histiocytic Sarcoma				
Overall rate	1/50 (2%)	0/50 (0%)	3/50 (6%)	1/50 (2%)
Adjusted rate	3.6%	0.0%	7.4%	2.7%
Terminal rate	1/28 (4%)	0/32 (0%)	1/36 (3%)	1/37 (3%)
First incidence (days)	735 (T)	—	581	735 (T)
Life table test	P= 0.530	P= 0.473N	P= 0.360	P= 0.699N
Logistic regression test	P= 0.471	P= 0.473N	P= 0.299	P= 0.699N
Cochran-Armitage test	P= 0.469			
Fisher exact test		P= 0.500N	P= 0.309	P= 0.753N
All Organs: Malignant Lymphoma				
Overall rate	12/50 (24%)	13/50 (26%)	12/50 (24%)	19/50 (38%)
Adjusted rate	35.7%	35.0%	30.0%	47.3%
Terminal rate	8/28 (29%)	9/32 (28%)	9/36 (25%)	16/37 (43%)
First incidence (days)	533	611	547	653
Life table test	P= 0.234	P= 0.554N	P= 0.378N	P= 0.318
Logistic regression test	P= 0.096	P= 0.547	P= 0.543N	P= 0.151
Cochran-Armitage test	P= 0.068			
Fisher exact test		P= 0.500	P= 0.592N	P= 0.097
All Organs: Benign Neoplasms				
Overall rate	26/50 (52%)	34/50 (68%)	26/50 (52%)	25/50 (50%)
Adjusted rate	70.9%	84.8%	60.4%	58.9%
Terminal rate	18/28 (64%)	26/32 (81%)	19/36 (53%)	20/37 (54%)
First incidence (days)	344	623	581	611
Life table test	P= 0.032N	P= 0.243	P= 0.230N	P= 0.129N
Logistic regression test	P= 0.137N	P= 0.114	P= 0.476N	P= 0.392N
Cochran-Armitage test	P= 0.243N			
Fisher exact test		P= 0.076	P= 0.579N	P= 0.500N

TABLE D3
Statistical Analysis of Primary Neoplasms in Female Mice in the 2-Year Inhalation Study of Isobutyraldehyde (continued)

	Chamber Control	500 ppm	1,000 ppm	2,000 ppm
All Organs: Malignant Neoplasms				
Overall rate	25/50 (50%)	28/50 (56%)	26/50 (52%)	24/50 (48%)
Adjusted rate	62.2%	58.8%	56.1%	55.7%
Terminal rate	14/28 (50%)	13/32 (41%)	16/36 (44%)	18/37 (49%)
First incidence (days)	76	93	537	611
Life table test	P= 0.134N	P= 0.530	P= 0.342N	P= 0.176N
Logistic regression test	P= 0.428N	P= 0.297	P= 0.459	P= 0.469N
Cochran-Armitage test	P= 0.378N			
Fisher exact test		P= 0.344	P= 0.500	P= 0.500N
All Organs: Benign or Malignant Neoplasms				
Overall rate	38/50 (76%)	45/50 (90%)	37/50 (74%)	40/50 (80%)
Adjusted rate	90.0%	91.8%	77.0%	86.9%
Terminal rate	24/28 (86%)	28/32 (88%)	25/36 (69%)	31/37 (84%)
First incidence (days)	76	93	537	611
Life table test	P= 0.070N	P= 0.391	P= 0.129N	P= 0.143N
Logistic regression test	P= 0.442N	P= 0.060	P= 0.486N	P= 0.523
Cochran-Armitage test	P= 0.500N			
Fisher exact test		P= 0.054	P= 0.500N	P= 0.405

(T)Terminal sacrifice

^a Number of neoplasm-bearing animals/number of animals examined. Denominator is number of animals examined microscopically for liver, lung, ovary, pancreatic islets, pituitary gland, and thyroid gland; for other tissues, denominator is number of animals necropsied.

^b Kaplan-Meier estimated neoplasm incidence at the end of the study after adjustment for intercurrent mortality

^c Observed incidence at terminal kill

^d Beneath the chamber control incidence are the P values associated with the trend test. Beneath the exposed group incidence are the P values corresponding to pairwise comparisons between the chamber controls and that exposed group. The life table test regards neoplasms in animals dying prior to terminal kill as being (directly or indirectly) the cause of death. The logistic regression test regards these lesions as nonfatal. The Cochran-Armitage and Fisher exact tests compare directly the overall incidence rates. For all tests, a negative trend or a lower incidence in an exposure group is indicated by **N**.

^e Not applicable; no neoplasms in animal group

^f Value of statistic cannot be computed.

TABLE D4a
Historical Incidence of Malignant Lymphoma in Chamber Control Female B6C3F₁ Mice^a

Study	Incidence in Controls	
Historical Incidence at Battelle Pacific Northwest Laboratories		
1,3-Butadiene	6/50	
Acetonitrile	11/49	
Allyl Glycidyl Ether	22/50	
2-Chloroacetophenone	22/50	
<i>l</i> -Epinephrine Hydrochloride	16/50	
Chloroethane	4/49	
Hexachlorocyclopentadiene	13/49	
CS ₂ (<i>o</i> -Chlorobenzalmalononitrile)	21/50	
Ozone	7/50	
Overall Historical Incidence		
Total	206/941 (21.9%)	
Standard deviation	13.3%	
Range	8%-44%	

^a Data as of 12 May 1995. Includes data for histiocytic, lymphocytic, mixed, NOS, and undifferentiated cell type lymphomas

TABLE D4b
Historical Incidence of Ovarian Neoplasms in Chamber Control Female B6C3F₁ Mice^a

Study	Incidence in Controls	
	Cystadenoma	Cystadenocarcinoma
Historical Incidence at Battelle Pacific Northwest Laboratories		
1,3-Butadiene	0/49	0/49
Acetonitrile	1/48	0/48
Allyl Glycidyl Ether	0/49	0/49
2-Chloroacetophenone	0/50	0/50
<i>l</i> -Epinephrine Hydrochloride	3/50	0/50
Chloroethane	0/49	0/49
Hexachlorocyclopentadiene	0/49	0/49
CS ₂ (<i>o</i> -Chlorobenzalmalononitrile)	0/50	0/50
Ozone	1/50	0/50
Overall Historical Incidence		
Total	15/921 (1.6%)	1/921 (0.1%)
Standard deviation	1.8%	0.2%
Range	0%-6%	0%-1%

^a Data as of 12 May 1995

TABLE D5
Summary of the Incidence of Nonneoplastic Lesions in Female Mice in the 2-Year Inhalation Study
of Isobutyraldehyde^a

	Chamber Control	500 ppm	1,000 ppm	2,000 ppm
Disposition Summary				
Animals initially in study	50	50	50	50
Early deaths				
Accidental deaths	1	1		
Moribund	16	13	10	11
Natural deaths	5	4	4	2
Survivors				
Died last week of study			1	
Terminal sacrifice	28	32	35	37
Animals examined microscopically	50	50	50	50
Alimentary System				
Gallbladder	(46)	(44)	(45)	(47)
Hyperplasia		1 (2%)		1 (2%)
Intestine small, ileum	(49)	(46)	(47)	(49)
Hyperplasia, lymphoid	1 (2%)		1 (2%)	
Liver	(49)	(49)	(50)	(50)
Angiectasis			2 (4%)	
Basophilic focus	1 (2%)	3 (6%)	2 (4%)	3 (6%)
Clear cell focus	1 (2%)		2 (4%)	
Cyst		1 (2%)	1 (2%)	
Eosinophilic focus	6 (12%)	7 (14%)	5 (10%)	4 (8%)
Hematopoietic cell proliferation		1 (2%)		1 (2%)
Mixed cell focus			1 (2%)	
Necrosis	4 (8%)	3 (6%)	1 (2%)	1 (2%)
Tension lipidosis	3 (6%)		2 (4%)	
Thrombosis		1 (2%)		
Centrilobular, necrosis	1 (2%)	2 (4%)	2 (4%)	
Mesentery	(8)	(2)	(4)	(3)
Hemorrhage				1 (33%)
Fat, necrosis	6 (75%)	2 (100%)		2 (67%)
Pancreas	(50)	(49)	(50)	(50)
Atrophy	1 (2%)			1 (2%)
Basophilic focus	1 (2%)			
Cyst	2 (4%)	1 (2%)		1 (2%)
Hypertrophy			1 (2%)	1 (2%)
Inflammation, chronic active	1 (2%)		1 (2%)	2 (4%)
Lipomatosis	4 (8%)	1 (2%)	3 (6%)	3 (6%)
Thrombosis	1 (2%)			
Stomach, forestomach	(50)	(50)	(50)	(50)
Diverticulum				1 (2%)
Hyperplasia, squamous	1 (2%)	1 (2%)		3 (6%)
Inflammation, chronic active	1 (2%)	1 (2%)	1 (2%)	3 (6%)
Stomach, glandular	(49)	(49)	(50)	(50)
Inflammation, chronic active			1 (2%)	
Mineralization		1 (2%)		
Tooth				(1)
Developmental malformation				1 (100%)

^a Number of animals examined microscopically at the site and the number of animals with lesion

TABLE D5
Summary of the Incidence of Nonneoplastic Lesions in Female Mice in the 2-Year Inhalation Study
of Isobutyraldehyde (continued)

	Chamber Control	500 ppm	1,000 ppm	2,000 ppm
Cardiovascular System				
Heart	(50)	(50)	(50)	(50)
Cardiomyopathy	9 (18%)	12 (24%)	10 (20%)	7 (14%)
Artery, mineralization		1 (2%)		
Atrium, thrombosis	1 (2%)			
Endocrine System				
Adrenal cortex	(50)	(49)	(50)	(50)
Atrophy	1 (2%)			
Degeneration, fatty	2 (4%)	2 (4%)	1 (2%)	1 (2%)
Hyperplasia	5 (10%)	3 (6%)		1 (2%)
Hypertrophy			1 (2%)	1 (2%)
Necrosis			1 (2%)	
Adrenal medulla	(50)	(49)	(50)	(50)
Hyperplasia	5 (10%)	3 (6%)	2 (4%)	1 (2%)
Pituitary gland	(50)	(49)	(50)	(49)
Pars distalis, hyperplasia	19 (38%)	23 (47%)	23 (46%)	17 (35%)
Pars intermedia, hyperplasia			1 (2%)	
Pars intermedia, hypertrophy	1 (2%)			1 (2%)
Thyroid gland	(50)	(50)	(50)	(50)
Follicular cell, hyperplasia	18 (36%)	26 (52%)	24 (48%)	32 (64%)
General Body System				
None				
Genital System				
Clitoral gland	(44)	(39)	(40)	(40)
Inflammation, chronic active		1 (3%)		
Ovary	(50)	(49)	(50)	(50)
Angiectasis			2 (4%)	
Cyst	13 (26%)	15 (31%)	14 (28%)	18 (36%)
Hyperplasia				1 (2%)
Interstitial cell, hyperplasia				1 (2%)
Uterus	(50)	(50)	(50)	(50)
Angiectasis	2 (4%)			1 (2%)
Hemorrhage			1 (2%)	
Hydrometra	4 (8%)	4 (8%)	6 (12%)	7 (14%)
Inflammation, suppurative		1 (2%)		
Thrombosis				1 (2%)
Hematopoietic System				
Lymph node	(5)	(5)	(4)	(4)
Lumbar, ectasia			1 (25%)	
Lumbar, hemorrhage				1 (25%)
Lymph node, bronchial	(42)	(38)	(42)	(44)
Hemorrhage	1 (2%)			
Lymph node, mesenteric	(48)	(49)	(47)	(47)
Angiectasis				1 (2%)
Necrosis			1 (2%)	

TABLE D5
Summary of the Incidence of Nonneoplastic Lesions in Female Mice in the 2-Year Inhalation Study
of Isobutyraldehyde (continued)

	Chamber Control	500 ppm	1,000 ppm	2,000 ppm
Hematopoietic System (continued)				
Spleen	(50)	(49)	(50)	(50)
Congestion	1 (2%)			
Hematopoietic cell proliferation	11 (22%)	11 (22%)	11 (22%)	9 (18%)
Hyperplasia, lymphoid	2 (4%)	2 (4%)	3 (6%)	
Integumentary System				
Skin	(50)	(50)	(50)	(50)
Inflammation, acute	1 (2%)			
Inflammation, chronic active				1 (2%)
Subcutaneous tissue, angiectasis			1 (2%)	
Subcutaneous tissue, necrosis				1 (2%)
Musculoskeletal System				
Bone	(50)	(50)	(50)	(50)
Fracture		1 (2%)		
Hyperostosis			1 (2%)	
Skeletal muscle		(1)	(1)	
Hemorrhage		1 (100%)		
Nervous System				
Brain	(50)	(50)	(50)	(50)
Meninges, infiltration cellular, mononuclear cell				1 (2%)
Respiratory System				
Larynx	(50)	(50)	(49)	(50)
Inflammation, suppurative			1 (2%)	
Epiglottis, hyperplasia				1 (2%)
Epiglottis, metaplasia, squamous				1 (2%)
Lung	(50)	(50)	(50)	(50)
Congestion, chronic	1 (2%)			
Hemorrhage	1 (2%)	1 (2%)		
Inflammation, suppurative	1 (2%)			
Mineralization				1 (2%)
Thrombosis		1 (2%)		
Alveolar epithelium, hyperplasia	3 (6%)	3 (6%)		1 (2%)
Alveolus, infiltration cellular, histiocyte	2 (4%)	2 (4%)	1 (2%)	
Bronchiole, hyperplasia	1 (2%)			
Interstitialium, fibrosis	1 (2%)			
Nose	(50)	(50)	(50)	(50)
Inflammation, suppurative	1 (2%)	1 (2%)	1 (2%)	
Thrombosis		1 (2%)		
Olfactory epithelium, degeneration	1 (2%)	1 (2%)	27 (54%)	49 (98%)
Olfactory epithelium, degeneration, hyaline			1 (2%)	
Olfactory epithelium, necrosis			2 (4%)	1 (2%)
Respiratory epithelium, necrosis			1 (2%)	

TABLE D5
Summary of the Incidence of Nonneoplastic Lesions in Female Mice in the 2-Year Inhalation Study
of Isobutyraldehyde (continued)

	Chamber Control	500 ppm	1,000 ppm	2,000 ppm
Special Senses System				
Eye				(3)
Cornea, mineralization				2 (67%)
Lens, mineralization				1 (33%)
Harderian gland	(3)	(4)	(2)	(2)
Hyperplasia				1 (50%)
Urinary System				
Kidney	(50)	(50)	(50)	(50)
Amyloid deposition	2 (4%)	1 (2%)		
Atrophy			1 (2%)	
Cyst	1 (2%)		1 (2%)	
Infarct	1 (2%)	2 (4%)		2 (4%)
Metaplasia, osseous		1 (2%)	4 (8%)	1 (2%)
Mineralization		1 (2%)	2 (4%)	
Nephropathy	23 (46%)	20 (40%)	15 (30%)	20 (40%)
Pelvis, dilatation			1 (2%)	
Pelvis, inflammation, acute	1 (2%)			
Renal tubule, necrosis		1 (2%)	1 (2%)	

APPENDIX E

GENETIC TOXICOLOGY

<i>SALMONELLA TYPHIMURIUM</i> MUTAGENICITY TEST PROTOCOL	188
MOUSE LYMPHOMA MUTAGENICITY TEST PROTOCOL	188
CHINESE HAMSTER OVARY CELL CYTOGENETICS PROTOCOLS	189
<i>DROSOPHILA MELANOGASTER</i> TEST PROTOCOL	190
MOUSE BONE MARROW CHROMOSOMAL ABERRATIONS TEST PROTOCOL	190
RAT AND MOUSE BONE MARROW MICRONUCLEUS TEST PROTOCOL	191
RESULTS	191
TABLE E1 Mutagenicity of Isobutyraldehyde in <i>Salmonella typhimurium</i>	193
TABLE E2 Induction of Trifluorothymidine Resistance in L5178Y Mouse Lymphoma Cells by Isobutyraldehyde	199
TABLE E3 Induction of Sister Chromatid Exchanges in Chinese Hamster Ovary Cells by Isobutyraldehyde	201
TABLE E4 Induction of Chromosomal Aberrations in Chinese Hamster Ovary Cells by Isobutyraldehyde	203
TABLE E5 Induction of Sex-Linked Recessive Lethal Mutations in <i>Drosophila melanogaster</i> by Isobutyraldehyde	204
TABLE E6 Induction of Chromosomal Aberrations in Mouse Bone Marrow Cells by Isobutyraldehyde	204
TABLE E7 Induction of Micronuclei in Bone Marrow Polychromatic Erythrocytes of Rats and Mice Treated with Isobutyraldehyde by Intraperitoneal Injection	205

GENETIC TOXICOLOGY

SALMONELLA TYPHIMURIUM MUTAGENICITY TEST PROTOCOL

Testing was performed in study 1 as reported by Mortelmans *et al.* (1986) and in study 2 as reported in Zeiger *et al.* (1992). Isobutyraldehyde was sent to the laboratory as a coded aliquot from Radian Corporation (Austin, TX). It was incubated with the *Salmonella typhimurium* tester strains (TA97, TA98, TA100, TA102, TA104, TA1535, and TA1537) either in buffer or S9 mix (metabolic activation enzymes and cofactors from Aroclor 1254-induced male Sprague-Dawley rat or Syrian hamster liver) for 20 minutes at 37° C. Top agar supplemented with L-histidine and d-biotin was added, and the contents of the tubes were mixed and poured onto the surfaces of minimal glucose agar plates. Histidine-independent mutant colonies arising on these plates were counted following incubation for 2 days at 37° C.

Each trial consisted of triplicate plates of concurrent positive and negative controls and at least four doses of isobutyraldehyde. The high dose was limited by experimental design to 10,000 µg/plate.

In this assay, a positive response is defined as a reproducible, dose-related increase in histidine-independent (revertant) colonies in any one strain/activation combination. An equivocal response is defined as an increase in revertants that is not dose related, not reproducible, or not of sufficient magnitude to support a determination of mutagenicity. A negative response is obtained when no increase in revertant colonies is observed following chemical treatment. There was no minimum percentage or fold increase required for a chemical to be judged positive or weakly positive.

MOUSE LYMPHOMA MUTAGENICITY TEST PROTOCOL

The experimental protocol is presented in detail by Myhr *et al.* (1985). Isobutyraldehyde was supplied as a coded aliquot by Radian Corporation. The high dose of 1,000 µg/mL was determined by toxicity. L5178Y mouse lymphoma cells were maintained at 37° C as suspension cultures in supplemented Fischer's medium; normal cycling time was approximately 10 hours. To reduce the number of spontaneously occurring cells resistant to trifluorothymidine (TFT), subcultures were exposed to medium containing thymidine, hypoxanthine, methotrexate, and glycine for 1 day; to medium containing thymidine, hypoxanthine, and glycine for 1 day; and to normal medium for 3 to 5 days. For cloning, the horse serum content was increased and Noble agar was added.

All treatment levels within an experiment, including concurrent positive and solvent controls, were replicated. Treated cultures contained 6×10^6 cells in 10 mL medium. Incubation with isobutyraldehyde continued for 4 hours, at which time the medium plus isobutyraldehyde was removed and the cells were resuspended in fresh medium and incubated for an additional 2 days to express the mutant phenotype. Cell density was monitored so that log phase growth was maintained. After the 48-hour expression period, cells were plated in medium and soft agar supplemented with TFT for selection of TFT-resistant cells, and cells were plated in nonselective medium and soft agar to determine cloning efficiency. Plates were incubated at 37° C in 5% CO₂ for 10 to 12 days.

Minimum criteria for accepting an experiment as valid and a detailed description of the statistical analysis and data evaluation are presented in Caspary *et al.* (1988). All data were evaluated statistically for trend and peak responses. Both responses had to be significant ($P \leq 0.05$) for isobutyraldehyde to be considered positive, i.e., capable of inducing TFT resistance. A single significant response led to a call of "questionable," and the absence of both a trend and peak response resulted in a "negative" call.

CHINESE HAMSTER OVARY CELL CYTOGENETICS PROTOCOLS

Testing was performed as reported by Galloway *et al.* (1987). Isobutyraldehyde was sent to the laboratory as a coded aliquot by Radian Corporation. It was tested in cultured Chinese hamster ovary (CHO) cells for induction of sister chromatid exchanges (SCEs) and chromosomal aberrations (Abs), both in the presence and absence of Aroclor 1254-induced male Sprague-Dawley rat liver S9 and cofactor mix. Cultures were handled under gold lights to prevent photolysis of bromodeoxyuridine-substituted DNA. Each test consisted of concurrent solvent and positive controls and of at least four doses of isobutyraldehyde; the high dose was limited by toxicity. A single flask per dose was used, and each test was repeated.

Sister Chromatid Exchange Test: In the SCE test without S9, CHO cells were incubated for 26 hours with isobutyraldehyde in McCoy's 5A medium. Bromodeoxyuridine (BrdU) was added 2 hours after culture initiation. After 26 hours, the medium containing isobutyraldehyde was removed and replaced with fresh medium plus BrdU and Colcemid, and incubation was continued for 2 hours. Cells were then harvested by mitotic shake-off, fixed, and stained with Hoechst 33258 and Giemsa. In the SCE test with S9, cells were incubated with isobutyraldehyde, serum-free medium, and S9 for 2 hours. The medium was then removed and replaced with medium containing serum and BrdU and no isobutyraldehyde and incubation proceeded for an additional 26 hours, with Colcemid present for the final 2 hours. Harvesting and staining were the same as for cells treated without S9. All slides were scored blind and those from a single test were read by the same person. Fifty second-division metaphase cells were scored for frequency of SCEs/cell from each dose level. Because significant chemical-induced cell cycle delay was seen at the 250 and 500 µg/mL doses in trial 2 without S9, incubation time was lengthened to ensure a sufficient number of scorable (second-division metaphase) cells.

Statistical analyses were conducted on the slopes of the dose-response curves and the individual dose points (Galloway *et al.*, 1987). An SCE frequency 20% above the concurrent solvent control value was chosen as a statistically conservative positive response. The probability of this level of difference occurring by chance at one dose point is less than 0.01; the probability for such a chance occurrence at two dose points is less than 0.001. An increase of 20% or greater at any single dose was considered weak evidence of activity; increases at two or more doses resulted in a determination that the trial was positive. A statistically significant trend ($P < 0.005$) in the absence of any responses reaching 20% above background led to a call of equivocal.

Chromosomal Aberrations Test: In the Abs test without S9, cells were incubated in McCoy's 5A medium with isobutyraldehyde for 10 to 10.5 hours; Colcemid was added and incubation continued for 2 hours. The cells were then harvested by mitotic shake-off, fixed, and stained with Giemsa. For the Abs test with S9, cells were treated with isobutyraldehyde and S9 for 2 hours, after which the treatment medium was removed and the cells were incubated for 10 hours in fresh medium, with Colcemid present for the final 2 hours. Cells were harvested in the same manner as for the treatment without S9. The harvest time for the Abs test was based on the cell cycle information obtained in the SCE test.

Cells were selected for scoring on the basis of good morphology and completeness of karyotype (21 ± 2 chromosomes). All slides were scored blind and those from a single test were read by the same person. One hundred first-division metaphase cells were scored at each dose level. Classes of aberrations included simple (breaks and terminal deletions), complex (rearrangements and translocations), and other (pulverized cells, despiralized chromosomes, and cells containing 10 or more aberrations).

Chromosomal aberration data are presented as percentage of cells with aberrations. To arrive at a statistical call for a trial, analyses were conducted on both the dose response curve and individual dose points. For a single trial, a statistically significant ($P \leq 0.05$) difference for one dose point and a significant trend ($P \leq 0.015$) were considered weak evidence for a positive response; significant differences for two or more doses indicated the trial was positive. A positive trend test in the absence of a statistically significant

increase at any one dose resulted in an equivocal call (Galloway *et al.*, 1987). Ultimately, the trial calls were based on a consideration of the statistical analyses as well as the biological information available to the reviewers.

***DROSOPHILA MELANOGASTER* TEST PROTOCOL**

The assay for induction of sex-linked recessive lethal (SLRL) mutations was performed with adult flies as described by Woodruff *et al.* (1985). Isobutyraldehyde was supplied as a coded aliquot by Radian Corporation. It was assayed in the SLRL test by feeding for 3 days to adult Canton-S wild-type males no more than 24 hours old at the beginning of treatment. Because the response was negative, isobutyraldehyde was retested by injection into adult males.

To administer isobutyraldehyde by injection, a glass Pasteur pipette was drawn out in a flame to a microfine filament, and the tip was broken off to allow delivery of the test solution. Injection was performed either manually, by attaching a rubber bulb to the other end of the pipette and forcing through sufficient solution (0.2 to 0.3 μ L) to slightly distend the abdomen of the fly, or by attaching the pipette to a microinjector that automatically delivered a calibrated volume. Flies were anesthetized with ether and immobilized on a strip of tape. Injection into the thorax, under the wing, was performed with the aid of a dissecting microscope.

Toxicity tests were performed to set concentrations of isobutyraldehyde at a level that would induce 30% mortality after 72 hours of feeding or 24 hours after injection, while keeping induced sterility at an acceptable level. Oral exposure was achieved by allowing Canton-S males to feed for 72 hours on a solution of isobutyraldehyde in 5% sucrose. In the injection experiments, 24- to 72-hour old Canton-S males were treated with an aqueous solution of isobutyraldehyde dissolved in saline and allowed to recover for 24 hours. A concurrent saline control group was also included. Treated males were mated to three *Basc* females for 3 days and given fresh females at 2-day intervals to produce three matings of 3, 2, and 2 days (in each case, sample sperm from successive matings were treated at successively earlier post-meiotic stages). F_1 heterozygous females were mated with their siblings and then placed in individual vials. F_1 daughters from the same parental male were kept together to identify clusters. (A cluster occurs when a number of mutants from a given male result from a single spontaneous premeiotic mutation event, and is identified when the number of mutants from that male exceeds the number predicted by a Poisson distribution.) If a cluster was identified, all data from the male in question were discarded. Presumptive lethal mutations were identified as vials containing fewer than 5% of the expected number of wild-type males after 17 days; these were retested to confirm the response.

SLRL data were analyzed by simultaneous comparison with the concurrent and historical controls, using a normal approximation to the binomial test (Margolin *et al.*, 1983). A test result was considered positive if the P value was less than or equal to 0.01 and the mutation frequency in the tested group was greater than 0.10% or if the P value was less than or equal to 0.05 and the frequency in the treatment group was greater than 0.15%. A test was considered to be inconclusive if the P value was between 0.05 and 0.01 but the frequency in the treatment group was between 0.10% and 0.15% or the P value was between 0.10 and 0.05 but the frequency in the treatment group was greater than 0.10%. A test was considered negative if P was less than or equal to 0.10 or if the frequency in the treatment group was less than 0.10%.

MOUSE BONE MARROW CHROMOSOMAL ABERRATIONS TEST PROTOCOL

A dose range-finding study was performed in the absence of adequate toxicity information from the literature. The highest dose, 2,000 mg/kg, was limited by toxicity. Isobutyraldehyde was tested for induction of Abs in mouse bone marrow in two trials with a standard harvest time of 17 hours.

Male B6C3F₁ mice (10 animals per exposure group) were injected intraperitoneally with isobutyraldehyde dissolved in corn oil (injection volume = 0.4 mL). Solvent control mice received equivalent injections of corn oil only. The positive control was dimethylbenzanthracene. The mice were subcutaneously implanted with a BrdU tablet (McFee *et al.*, 1983) 18 hours before the scheduled harvest. (This required BrdU implantation to precede injection with isobutyraldehyde by 1 hour.) The use of BrdU allowed selection of the appropriate cell population for scoring. (Abs induced by chemical administration are present in maximum number at the first metaphase following treatment; they decline in number during subsequent nuclear divisions due to cell death.) Two hours before sacrifice, the mice received an intraperitoneal injection of colchicine in saline. The animals were killed 17 hours after isobutyraldehyde injection (18 hours after BrdU dosing). One or both femurs were removed, and the marrow was flushed out with phosphate-buffered saline (pH 7.0). Cells were treated with a hypotonic salt solution, fixed, and dropped onto chilled slides. After a 24-hour drying period, the slides were stained (with fluorescence-plus-Giemsa) and scored.

Fifty first-division metaphase cells were scored from each of 10 animals per treatment group. Responses were evaluated as the percentage of aberrant metaphase cells, excluding gaps. The data were analyzed by a trend test (Margolin *et al.*, 1986).

RAT AND MOUSE BONE MARROW MICRONUCLEUS TEST PROTOCOL

The standard, three-exposure protocol is described by Shelby *et al.* (1993). Available LD₅₀ information was used to determine the doses to be tested. Male F344/N rats and B6C3F₁ mice were injected intraperitoneally three times at 24-hour intervals with isobutyraldehyde dissolved in corn oil; the total dosing volume was 0.4 mL. Solvent control animals were injected with 0.4 mL of corn oil only. The positive control animals received injections of cyclophosphamide. The animals were killed 24 hours after the third injection, and blood smears were prepared from bone marrow cells obtained from the femurs. Air-dried smears were fixed and stained; 2,000 polychromatic erythrocytes (PCEs) were scored for the frequency of micronucleated cells in each of up to five animals per dose group.

The results were tabulated as the mean of the pooled results from all animals within a treatment group plus or minus the standard error of the mean. The frequency of micronucleated cells among PCEs was analyzed by a statistical software package that tested for increasing trend over exposure groups using a one-tailed Cochran-Armitage trend test, followed by pairwise comparisons between each exposure group and the control group (Margolin *et al.*, 1990). In the presence of excess binomial variation, as detected by a binomial dispersion test, the binomial variance of the Cochran-Armitage test was adjusted upward in proportion to the excess variation. In the micronucleus test, an individual trial is considered positive if the trend test P value is less than or equal to 0.025 or if the P value for any single exposure group is less than or equal to 0.025 divided by the number of dose groups. A final call of positive for micronucleus induction is preferably based on reproducibly positive trials (as noted above). Ultimately, the final call is determined by the scientific staff after considering the results of statistical analyses, reproducibility of any effects observed, and the magnitudes of those effects.

RESULTS

Isobutyraldehyde (up to 10,000 µg/plate) was tested in two independent *S. typhimurium* gene mutation assays (Table E1; Mortelmans *et al.*, 1986). Results were negative for strains TA97, TA98, TA100, TA102, TA1535, and TA1537, with and without varying concentrations of rat and hamster liver S9 enzymes. In strain TA104 (study 2), an equivocal response was produced only in the presence of rat liver S9. Isobutyraldehyde (62.5 to 1,000 µg/mL) was strongly mutagenic in the mouse lymphoma assay in the absence of S9; the assay was not conducted with S9 (Table E2). In cytogenetic tests with cultured CHO cells, isobutyraldehyde induced a strong, dose-related increase in SCEs, with and without S9 (Table E3). In

the absence of S9, positive responses were noted with isobutyraldehyde concentrations of 5 to 500 µg/mL; cell cycle delay occurred at the 250 and 500 µg/mL concentrations in the second trial without S9, and culture times were extended accordingly. With S9, doses of 160 to 1,250 µg/mL produced significant increases in SCEs; no cell cycle delay was noted at any of the doses tested in the presence of S9. Results of the Abs test in cultured CHO cells (Table E4) were also positive, but only in the absence of S9. With S9, the first trial gave negative results and the second trial was considered to be questionable, based on an increase in the percentage of cells with Abs that was seen at the middle dose of 750 µg/mL. None of the CHO cell cultures in this test required an extended period of incubation to offset chemical-induced cell cycle delay.

Isobutyraldehyde did not induce sex-linked recessive lethal mutations in germ cells of male *D. melanogaster* administered isobutyraldehyde in feed (80,000 ppm) or by injection (50,000 ppm) (Table E5; Woodruff *et al.*, 1985).

Results of *in vivo* tests for genetic damage induced in mammals by isobutyraldehyde were mixed, and the apparent contradictions in the data are not easily explained. Results of a test for induction of Abs in mouse bone marrow following a single intraperitoneal injection of isobutyraldehyde were clearly positive in each of two trials (Table E6), thus confirming *in vivo* the response observed in cultured CHO cells exposed to isobutyraldehyde *in vitro*. In this test, increasing doses of isobutyraldehyde produced increasing frequencies of aberrant cells. However, significant increases in the frequency of aberrant cells were seen only at doses that produced notable clinical signs of toxicity, and no significant increases in Abs were observed below 1,500 mg/kg. The highest viable dose tested was 1,750 mg/kg. In contrast to the positive results in the Abs assay (in which the total duration of exposure was 17 hours), negative results were obtained in two independent mouse bone marrow micronucleus tests with isobutyraldehyde administered three times at 24-hour intervals (Table E7). The highest dose used in these mouse bone marrow micronucleus tests was 1,250 mg/kg, which gave a higher total dose (3,750 mg/kg) over the 72-hour exposure period, but a lower single individual dose compared with the Abs study. In addition, a rat bone marrow micronucleus test was conducted with isobutyraldehyde, using the same protocol as the mouse study, and results were also negative (Table E7). The micronucleus test indirectly measures numerical and structural chromosome damage. Therefore, the negative micronucleus data are somewhat problematic in light of the positive results from the Abs assay, which demonstrated the presence of structural chromosomal damage in mouse bone marrow cells after isobutyraldehyde exposure. However, it is likely that the highest single dose is an important factor in the assessment of the *in vivo* genetic damage produced by this unstable reactive chemical in these tests. The chemical characteristics of isobutyraldehyde may negate the concept of a total accumulated dose and, therefore, it must be considered that a single exposure to 1,250 mg/kg isobutyraldehyde would likely be insufficient (based on the Abs data) to produce a detectable response in the micronucleus assay.

TABLE E1
Mutagenicity of Isobutyraldehyde in *Salmonella typhimurium*^a

Strain	Dose ($\mu\text{g}/\text{plate}$)	Revertants/plate ^b					
		-S9		+ 10% hamster S9		+ 10% rat S9	
		Trial 1	Trial 2	Trial 1	Trial 2	Trial 1	Trial 2
Study 1							
TA100	0	120 \pm 3.2	98 \pm 6.4	106 \pm 4.4	108 \pm 10.7	111 \pm 7.8	117 \pm 3.9
	100	110 \pm 8.4	79 \pm 6.5	118 \pm 6.7	84 \pm 8.4	109 \pm 15.9	94 \pm 8.2
	333	101 \pm 1.5	80 \pm 0.3	126 \pm 10.3	78 \pm 1.2	114 \pm 17.1	86 \pm 8.5
	1,000	108 \pm 9.1	80 \pm 6.0	122 \pm 10.0	78 \pm 6.0	101 \pm 14.9	92 \pm 9.9
	3,333	109 \pm 12.2	81 \pm 3.6	112 \pm 6.6	75 \pm 1.2	105 \pm 1.7	64 \pm 8.4
	10,000	Toxic	82 \pm 8.4	115 \pm 3.6	89 \pm 0.6	78 \pm 12.5	87 \pm 9.2
	Trial summary	Negative	Negative	Negative	Negative	Negative	Negative
Positive control ^c	358 \pm 15.5	292 \pm 10.0	381 \pm 7.9	447 \pm 18.5	146 \pm 2.8	188 \pm 17.4	
TA1535	0	24 \pm 2.6	19 \pm 0.0	10 \pm 2.4	13 \pm 0.6	10 \pm 2.2	9 \pm 2.1
	100	35 \pm 4.8	22 \pm 2.2	10 \pm 2.1	7 \pm 2.5	10 \pm 2.8	4 \pm 0.9
	333	31 \pm 7.8	16 \pm 2.0	12 \pm 1.5	6 \pm 0.9	11 \pm 3.7	7 \pm 0.3
	1,000	39 \pm 4.0	18 \pm 1.5	14 \pm 1.9	5 \pm 0.6	6 \pm 1.2	8 \pm 0.9
	3,333	Toxic	15 \pm 1.8	11 \pm 1.2	4 \pm 1.5	6 \pm 1.0	7 \pm 0.9
	10,000	Toxic	16 \pm 4.6	8 \pm 3.0	5 \pm 0.7	7 \pm 1.9	8 \pm 2.1
	Trial summary	Negative	Negative	Negative	Negative	Negative	Negative
Positive control	375 \pm 15.5	292 \pm 10.0	381 \pm 7.9	447 \pm 18.5	146 \pm 2.8	188 \pm 17.4	
TA1537	0	5 \pm 0.6	5 \pm 0.6	6 \pm 1.0	6 \pm 1.2	7 \pm 0.7	5 \pm 0.6
	100	4 \pm 1.0	4 \pm 1.9	10 \pm 1.8	7 \pm 0.7	9 \pm 0.3	8 \pm 0.0
	333	7 \pm 0.9	3 \pm 0.9	8 \pm 0.3	5 \pm 0.3	8 \pm 3.0	6 \pm 0.9
	1,000	5 \pm 1.3	3 \pm 1.2	10 \pm 1.3	8 \pm 3.2	5 \pm 2.0	5 \pm 0.3
	3,333	Toxic	4 \pm 1.2	8 \pm 2.2	4 \pm 0.9	9 \pm 4.4	5 \pm 1.3
	10,000	Toxic	9 \pm 2.0	7 \pm 3.5	8 \pm 1.2	6 \pm 1.5	7 \pm 1.0
	Trial summary	Negative	Negative	Negative	Negative	Negative	Negative
Positive control	184 \pm 4.7	129 \pm 6.9	424 \pm 75.9	436 \pm 28.4	157 \pm 8.7	135 \pm 17.4	
TA98	0	15 \pm 0.6	13 \pm 2.1	25 \pm 2.2	29 \pm 1.7	17 \pm 3.6	25 \pm 3.2
	100	24 \pm 1.9	13 \pm 3.5	36 \pm 3.0	17 \pm 2.7	30 \pm 1.7	20 \pm 0.6
	333	20 \pm 0.9	13 \pm 2.0	29 \pm 1.5	19 \pm 3.0	31 \pm 1.5	21 \pm 4.3
	1,000	20 \pm 3.2	12 \pm 3.0	32 \pm 0.3	23 \pm 4.1	30 \pm 1.5	21 \pm 2.7
	3,333	Toxic	13 \pm 2.5	33 \pm 1.8	18 \pm 3.1	30 \pm 4.8	18 \pm 0.9
	10,000	Toxic	17 \pm 5.7	33 \pm 4.9	25 \pm 3.0	26 \pm 2.9	23 \pm 4.4
	Trial summary	Negative	Negative	Negative	Negative	Negative	Negative
Positive control	626 \pm 20.6	415 \pm 6.7	1,274 \pm 85.7	1,461 \pm 63.9	473 \pm 34.3	507 \pm 6.6	

TABLE E1
Mutagenicity of Isobutyraldehyde in *Salmonella typhimurium* (continued)

Strain	Dose (µg/plate)	Revertants/plate					
		-S9		+ hamster S9		+ rat S9	
		Trial 1	Trial 2	10%	30%	10%	30%
Study 2							
TA102	0	217 ± 15.3	217 ± 4.0	256 ± 5.7	266 ± 9.1	248 ± 13.5	272 ± 7.9
	10	206 ± 9.1	238 ± 12.8				
	33	199 ± 19.3	253 ± 20.1	271 ± 3.7	294 ± 12.7	234 ± 12.4	247 ± 9.1
	100	213 ± 15.5	242 ± 8.2	236 ± 11.5	266 ± 31.3	262 ± 12.3	275 ± 18.7
	333	216 ± 16.5	245 ± 13.3	264 ± 16.1	269 ± 10.3	256 ± 9.7	267 ± 13.9
	1,000	134 ± 10.4	242 ± 23.1	252 ± 21.5	242 ± 5.5	233 ± 19.2	238 ± 9.9
	3,333			276 ± 6.2	228 ± 48.4	240 ± 23.6	283 ± 5.4
Trial summary		Negative	Negative	Negative	Negative	Negative	Negative
Positive control		798 ± 20.0	851 ± 16.1	903 ± 6.4	955 ± 15.9	636 ± 35.9	704 ± 28.9
TA100	0	182 ± 1.7	153 ± 3.1	189 ± 3.8	171 ± 4.4	166 ± 8.0	176 ± 11.4
	10		156 ± 3.2				
	33	169 ± 4.7	174 ± 11.9	199 ± 11.2		172 ± 8.4	
	100	174 ± 1.5	166 ± 5.3	200 ± 5.5	167 ± 7.4	192 ± 1.2	164 ± 17.6
	333	170 ± 5.5	165 ± 10.7	191 ± 9.7	182 ± 11.7	186 ± 1.2	176 ± 5.0
	1,000	111 ± 8.0	141 ± 13.0	194 ± 18.2	173 ± 9.1	168 ± 3.6	191 ± 6.2
	3,333			80 ± 16.0 ^d	164 ± 21.9	65 ± 6.4 ^d	161 ± 5.2
	6,666				124 ± 12.8 ^d	39 ± 9.2 ^d	
	10,000						73 ± 3.2 ^d
	Trial summary		Negative	Negative	Negative	Negative	Negative
Positive control		466 ± 15.3	696 ± 6.4	923 ± 32.0	638 ± 10.9	587 ± 31.0	443 ± 42.6
TA1535	0	10 ± 0.6	11 ± 1.5	9 ± 2.7	12 ± 1.0	8 ± 0.6	15 ± 1.7
	10	11 ± 0.9	7 ± 1.2				
	33	6 ± 0.9	9 ± 1.0	11 ± 2.6	12 ± 2.7	12 ± 1.2	
	100	11 ± 0.3	12 ± 2.0	8 ± 1.0	12 ± 0.9	11 ± 1.8	14 ± 1.7
	333	4 ± 0.6	10 ± 1.5	9 ± 1.7	12 ± 2.7	9 ± 2.3	10 ± 2.2
	1,000	13 ± 1.7	6 ± 2.1	11 ± 1.5	9 ± 1.5	11 ± 3.3	12 ± 0.7
	3,333			7 ± 1.2 ^d	14 ± 1.0	5 ± 1.2 ^d	9 ± 2.1
	6,666					1 ± 1.0 ^d	10 ± 0.9
Trial summary		Negative	Negative	Negative	Negative	Negative	Negative
Positive control		585 ± 19.9	532 ± 26.4	111 ± 3.2	256 ± 24.9	94 ± 4.2	106 ± 10.8
TA1537	0	4 ± 0.9	7 ± 0.3	8 ± 0.6	5 ± 1.3	7 ± 0.7	6 ± 2.0
	10	3 ± 0.6	8 ± 0.3				
	33	4 ± 0.3	7 ± 3.0	6 ± 0.7	6 ± 1.5	8 ± 0.7	7 ± 1.2
	100	5 ± 1.2	6 ± 0.0	8 ± 0.6	9 ± 2.0	8 ± 2.0	8 ± 0.3
	333	3 ± 0.3	7 ± 1.2	9 ± 2.0	7 ± 2.0	6 ± 0.7	8 ± 0.7
	1,000	4 ± 1.5	4 ± 1.5	7 ± 1.0	6 ± 0.6	7 ± 1.2	8 ± 0.7
	3,333			7 ± 1.2	8 ± 2.3	7 ± 0.7	7 ± 1.5
	Trial summary		Negative	Negative	Negative	Negative	Negative
Positive control		102 ± 14.3	183 ± 3.1	90 ± 6.4	90 ± 9.2	69 ± 9.9	64 ± 5.6

TABLE E1
Mutagenicity of Isobutyraldehyde in *Salmonella typhimurium* (continued)

Strain	Dose ($\mu\text{g}/\text{plate}$)	Revertants/plate			
		-S9			
		Trial 1	Trial 2	Trial 3	
Study 2 (continued)					
TA98	0	19 \pm 0.9	18 \pm 1.20	26 \pm 3.8	
	3		24 \pm 3.5		
	10		22 \pm 1.5	29 \pm 0.3	
	33	22 \pm 4.6	24 \pm 2.3	28 \pm 1.5	
	100	21 \pm 2.2	18 \pm 1.2	29 \pm 4.7	
	333	20 \pm 4.7	24 \pm 3.7	26 \pm 4.5	
	1,000	2 \pm 1.5 ^d		21 \pm 4.6	
	1,666	0 \pm 0.0 ^d			
Trial summary	Negative	Negative	Negative		
Positive control	399 \pm 23.8	825 \pm 31.3	1,046 \pm 3.2		
		+ hamster S9		+ rat S9	
		10%	30%	10%	30%
TA98	0	22 \pm 2.1	28 \pm 5.4	22 \pm 2.0	25 \pm 4.5
	33	25 \pm 3.8		29 \pm 3.3	
	100	19 \pm 3.8	24 \pm 2.2	19 \pm 1.9	31 \pm 4.0
	333	22 \pm 2.2	23 \pm 2.7	23 \pm 1.8	24 \pm 1.8
	1,000	23 \pm 3.7	21 \pm 2.6	17 \pm 2.5	23 \pm 1.9
	3,333	3 \pm 1.7 ^d	16 \pm 0.9	6 \pm 1.8 ^d	19 \pm 2.6
	6,666		1 \pm 1.3 ^d	12 \pm 5.9 ^d	
	10,000				9 \pm 3.0 ^d
Trial summary	Negative	Negative	Negative	Negative	
Positive control	700 \pm 44.7	345 \pm 9.1	347 \pm 20.2	129 \pm 3.8	

TABLE E1
Mutagenicity of Isobutyraldehyde in *Salmonella typhimurium* (continued)

Strain	Dose ($\mu\text{g}/\text{plate}$)	Revertants/plate			
		-S9		+ hamster S9	
		Trial 1	Trial 2	10%	30%
Study 2 (continued)					
TA104	0	367 \pm 8.1	258 \pm 22.4	385 \pm 6.4	487 \pm 3.5
	10	391 \pm 15.9	299 \pm 14.4		
	33	359 \pm 7.3	329 \pm 27.5	362 \pm 42.7	469 \pm 9.2
	100	353 \pm 9.5	300 \pm 12.4	369 \pm 6.7	456 \pm 1.7
	333	316 \pm 10.0	306 \pm 15.7	374 \pm 14.8	468 \pm 11.2
	1,000	328 \pm 22.5	233 \pm 29.2	316 \pm 17.2	496 \pm 19.6
	3,333			147 \pm 10.2 ^d	480 \pm 11.9
Trial summary		Negative	Negative	Negative	Negative
Positive control		796 \pm 45.2	1,031 \pm 38.5	1,295 \pm 31.8	968 \pm 20.1
+ rat S9					
		5%	10%	10%	30%
TA104	0	298 \pm 14.5	367 \pm 19.8	328 \pm 9.8	508 \pm 14.7
	10	335 \pm 13.6		360 \pm 4.8	
	33	390 \pm 3.4	390 \pm 13.2	348 \pm 19.5	498 \pm 12.3
	100	385 \pm 12.5	413 \pm 12.4	370 \pm 21.9	465 \pm 7.5
	333	372 \pm 13.0	456 \pm 5.0	396 \pm 9.7	471 \pm 8.3
	666	334 \pm 1.5		382 \pm 50.1	
	1,000	386 \pm 9.4	425 \pm 9.2	380 \pm 15.4	452 \pm 13.3
	3,333		86 \pm 13.8 ^d		398 \pm 17.4
	6,666		90 \pm 13.7 ^d		
Trial summary		Equivocal	Equivocal	Equivocal	Negative
Positive control		819 \pm 30.3	1,173 \pm 52.7	790 \pm 27.2	789 \pm 4.6

TABLE E1
Mutagenicity of Isobutyraldehyde in *Salmonella typhimurium* (continued)

Strain	Dose ($\mu\text{g}/\text{plate}$)	Revertants/plate									
		-S9			+ hamster S9						
		Trial 1	Trial 2	Trial 3	5%	10%	10%	30%	30%	30%	
Study 2 (continued)											
TA97	0	188 \pm 16.3	154 \pm 10.1	206 \pm 17.6							
	10	213 \pm 3.5	156 \pm 8.6	232 \pm 3.3							
	33	224 \pm 3.7	168 \pm 9.4	223 \pm 8.2							
	100	224 \pm 4.8	156 \pm 4.2	225 \pm 3.2							
	333	225 \pm 3.3	153 \pm 3.8	235 \pm 2.0							
	666		157 \pm 15.0								
	1,000	252 \pm 4.1	121 \pm 9.8	227 \pm 3.0							
	1,666		17 \pm 9.1 ^d								
	Trial summary		Equivocal	Negative	Negative						
	Positive control		554 \pm 8.3	453 \pm 10.5	480 \pm 16.0						
TA97	0	154 \pm 1.9	149 \pm 3.6	197 \pm 10.7	219 \pm 7.2	151 \pm 12.7	186 \pm 5.8				
	10										
	33			227 \pm 2.1	214 \pm 5.5						
	100	145 \pm 21.5	159 \pm 3.5	227 \pm 4.0	224 \pm 1.5	159 \pm 6.4	182 \pm 10.5				
	333	173 \pm 4.8	147 \pm 7.0	226 \pm 3.3	228 \pm 9.2	162 \pm 5.4	184 \pm 8.6				
	666	175 \pm 4.6	154 \pm 8.3			178 \pm 3.2	192 \pm 10.7				
	1,000	166 \pm 13.1	154 \pm 9.9	260 \pm 6.4	247 \pm 7.1	179 \pm 4.0	177 \pm 7.9				
	1,666	157 \pm 14.0	175 \pm 2.0			192 \pm 11.3	221 \pm 5.2				
	3,333	72 \pm 15.2 ^d	130 \pm 21.0 ^d	168 \pm 10.4 ^d	254 \pm 9.4	166 \pm 6.9					
	Trial summary		Negative	Negative	Equivocal	Negative	Equivocal	Negative			
Positive control		559 \pm 9.1	462 \pm 14.1	639 \pm 31.8	426 \pm 12.7	424 \pm 27.5	562 \pm 20.2				

TABLE E1
Mutagenicity of Isobutyraldehyde in *Salmonella typhimurium* (continued)

Strain	Dose ($\mu\text{g}/\text{plate}$)	Revertants/plate	
		+ rat S9	
		10%	30%
Study 2 (continued)			
TA97			
	0	187 \pm 12.4	258 \pm 0.6
	33	199 \pm 8.5	
	100	196 \pm 14.5	269 \pm 4.4
	333	197 \pm 10.1	243 \pm 16.2
	1,000	193 \pm 5.0	248 \pm 6.2
	3,333	108 \pm 8.8 ^d	214 \pm 6.3
	6,666	87 \pm 8.1 ^d	211 \pm 13.8
Trial summary		Negative	Negative
Positive control		376 \pm 5.5	378 \pm 19.7

^a Studies were performed at SRI International. The detailed protocol and the data for study 1 are presented in Mortelmans *et al.* (1986), and the detailed protocol for study 2 is presented in Zeiger *et al.* (1992).

^b Revertants are presented as mean \pm standard error from three plates.

^c The positive controls in the absence of metabolic activation were sodium azide (TA100 and TA1535), 9-aminoacridine (TA97 and TA1537), 4-nitro-*o*-phenylenediamine (TA98), mitomycin C (TA102), and methyl methanesulfonate (TA104). The positive control for metabolic activation with all strains was 2-aminoanthracene, and 2-aminoanthracene/sterigmatocystin was used for TA102.

^d Slight toxicity

TABLE E2
Induction of Trifluorothymidine Resistance in L5178Y Mouse Lymphoma Cells by Isobutyraldehyde^a

Compound	Concentration (µg/mL)	Cloning Efficiency (%)	Relative Total Growth (%)	Mutant Count	Mutant Fraction ^b	Average Mutant Fraction ^c
-S9						
Trial 1						
Ethanol ^d		95	78	93	33	
		100	93	95	32	
		86	83	78	30	
		99	147	118	40	34
Methyl methanesulfonate ^e	5	59	48	594	334	
		76	65	599	263	
		76	57	826	362	320*
Isobutyraldehyde	62.5	93	108	112	40	
		68	104	109	53	
		89	115	111	42	45
	125	66	67	127	64	
		74	73	123	55	
		77	54	164	71	64*
	250	67	46	237	119	
		56	51	243	144	
		62	41	219	118	127*
	500	57	26	411	240	
		64	38	434	225	
		97	40	502	173	213*
	1,000	64	46	361	187	
		71	11	357	168	178*
		Lethal				
	1,500	Lethal				
		Lethal				
		Lethal				

TABLE E2
Induction of Trifluorothymidine Resistance in L5178Y Mouse Lymphoma Cells by Isobutyraldehyde
 (continued)

Compound	Concentration (µg/mL)	Cloning Efficiency (%)	Relative Total Growth (%)	Mutant Count	Mutant Fraction	Average Mutant Fraction
-S9 (continued)						
Trial 2						
Ethanol		75	97	77	34	
		79	108	76	32	
		86	72	107	41	
		74	124	88	39	37
Methyl methanesulfonate	5	65	101	360	185	
		109	114	409	125	
		69	83	393	191	167*
Isobutyraldehyde	62.5	62	59	78	42	
		69	67	102	49	
		71	69	90	42	44
	125	51	45	141	93	
		65	61	127	65	
		42	41	120	95	84*
	250	47	42	162	115	
		45	35	209	157	
		44	32	289	221	164*
	500	33	15	383	391	
		46	22	532	383	
		43	13	566	442	405*
	750	Lethal				
		Lethal				

* Significant positive response ($P \leq 0.05$)

^a Study was performed at Litton Bionetics, Inc. The detailed protocol is presented in Myhr *et al.* (1985).

^b Mutant fraction (MF) (frequency) is a ratio of the mutant count to the cloning efficiency, divided by 3 (to arrive at MF/10⁶ cells treated).

^c Mean from three replicated plates of approximately 10⁶ cells each

^d Solvent control

^e Positive control

TABLE E3
Induction of Sister Chromatid Exchanges in Chinese Hamster Ovary Cells by Isobutyraldehyde^a

Compound	Dose (µg/mL)	Total Cells Scored	No. of Chromosomes	No. of SCEs	SCEs/Chromosome	SCEs/Cell	Hrs in BrdU	Relative Change of SCEs/Chromosome ^b (%)
-S9								
Trial 1								
Summary: Positive								
Dimethylsulfoxide ^c		50	1,050	406	0.38	8.1	26.0	
Mitomycin-C ^d	0.01	50	1,050	2,611	2.48	52.2	26.0	543.11
	0.01	50	1,049	2,497	2.38	49.9	26.0	515.62
Isobutyraldehyde	5	50	1,046	537	0.51	10.7	26.0	32.77
	16	50	1,050	737	0.70	14.7	26.0	81.53
	50	50	1,049	1,286	1.22	25.7	26.0	217.05
	160	50	1,047	1,918	1.83	38.4	26.0	373.78
	500	0						
					P < 0.001 ^e			
Trial 2								
Summary: Positive								
Dimethylsulfoxide		50	1,044	408	0.39	8.2	26.0	
Mitomycin-C	0.005	50	1,048	1,480	1.41	29.6	26.0	261.36
	0.005	50	1,047	1,561	1.49	31.2	26.0	281.50
Isobutyraldehyde	10	50	1,045	516	0.49	10.3	26.0	26.35*
	25	50	1,045	803	0.76	16.1	26.0	96.63*
	50	50	1,035	906	0.92	19.2	26.0	137.34*
	160	50	1,046	1,485	1.41	29.7	26.0	263.28*
	250	50	1,026	2,850	2.77	57.0	41.0 ^f	610.79*
	500	50	1,036	3,743	3.61	74.9	41.0 ^f	824.50*
					P < 0.001			
+ S9								
Trial 1								
Summary: Positive								
Dimethylsulfoxide		50	1,045	435	0.41	8.7	26.0	
Cyclophosphamide ^d	1.5	50	1,044	1,681	1.61	33.6	26.0	286.81
	2	50	1,046	2,461	2.35	49.2	26.0	465.22
Isobutyraldehyde	16	50	1,041	452	0.43	0.9	26.0	4.31
	50	50	1,044	486	0.46	9.7	26.0	11.83
	160	50	1,039	620	0.59	12.4	26.0	43.35*
	500	50	1,034	1,152	1.11	23.0	26.0	167.65*
	1,600 ^g	0						26.0
					P < 0.001			

TABLE E3
Induction of Sister Chromatid Exchanges in Chinese Hamster Ovary Cells by Isobutyraldehyde (continued)

Compound	Dose ($\mu\text{g/mL}$)	Total Cells Scored	No. of Chromo- somes	No. of SCEs	SCEs/ Chromo- some	SCEs/ Cell	Hrs in BrdU	Relative Change of SCEs/ Chromosomes (%)
+ S9 (continued)								
Trial 2								
Summary: Positive								
Dimethylsulfoxide		50	1,044	369	0.35	7.4	26.0	
Cyclophosphamide	2	50	1,043	2,086	2.00	41.7	26.0	465.87
	2	50	1,043	1,930	1.85	38.6	26.0	423.55
Isobutyraldehyde	500	50	1,045	1,170	1.11	23.4	26.0	216.78*
	750	50	1,040	1,301	1.25	26.0	26.0	253.94*
	1,000	50	1,032	2,269	2.19	45.4	26.0	522.07*
	1,250	50	1,032	2,906	2.81	58.1	26.0	696.71*
P < 0.001								

* Positive response ($\geq 20\%$ increase over solvent control)

^a Study was performed at Environmental Health Research and Testing, Inc. A detailed description of the protocol is presented in Galloway *et al.* (1987). SCE= sister chromatid exchange; BrdU= bromodeoxyuridine

^b SCEs/chromosome in treated cells versus SCEs/chromosome in solvent control cells

^c Solvent control

^d Positive control

^e Significance of SCEs/chromosome tested by the linear regression trend test versus log of the dose

^f Because isobutyraldehyde induced a delay in the cell division cycle, harvest time was extended to maximize the proportion of second-division cells available for analysis.

^g At the 1,600 $\mu\text{g/mL}$ dose level, many cells were endoreduplicated/polyploids.

TABLE E4
Induction of Chromosomal Aberrations in Chinese Hamster Ovary Cells by Isobutyraldehyde^a

-S9					+ S9				
Dose (µg/mL)	Total Cells	No. of Abs	Abs/ Cell	Cell with Abs (%)	Dose (µg/mL)	Total Cells	No. of Abs	Abs/ Cell	Cell with Abs (%)
Trial 1 - Harvest time: 12.5 hours Summary: Positive					Trial 1 - Harvest time: 12.0 hours Summary: Negative				
Dimethylsulfoxide ^b					Dimethylsulfoxide				
	100	1	0.01	1.0		100	3	0.03	3.0
Mitomycin-C ^c					Cyclophosphamide ^c				
0.5	100	52	0.52	39.0	50	100	50	0.50	38.0
Isobutyraldehyde					Isobutyraldehyde				
16	100	0	0.00	0.0	16	100	1	0.01	1.0
50	100	1	0.01	1.0	50	100	3	0.03	3.0
160	100	2	0.02	2.0	160	100	4	0.04	4.0
500	100	15	0.15	12.0*	500	100	5	0.05	5.0
1,600	100	35	0.35	27.0*	1,600	100	1	0.01	1.0
3,000	0				3,000	0			
4,000	0				4,000	0			
P < 0.001 ^d					P = 0.416				
Trial 2 - Harvest time: 12.0 hours Summary: Positive					Trial 2 - Harvest time: 12.0 hours Summary: Equivocal				
Dimethylsulfoxide					Dimethylsulfoxide				
	100	1	0.01	1.0		100	1	0.01	1.0
Mitomycin-C					Cyclophosphamide				
0.5	100	50	0.50	37.0	50	100	60	0.60	40.0
Isobutyraldehyde					Isobutyraldehyde				
500	100	9	0.09	9.0*	100	100	0	0.00	0.0
1,000	100	11	0.11	10.0*	250	100	4	0.04	4.0
1,500	100	16	0.16	8.0*	500	100	7	0.07	7.0
2,000	100	31	0.31	17.0*	750	100	14	0.14	14.0*
					1,000	100	3	0.03	3.0
					1,500	100	6	0.06	6.0
					2,000	100	1	0.01	1.0
P < 0.001					P = 0.018				

* Positive ($P \leq 0.05$)

^a Study was performed at Environmental Health Research and Testing, Inc. The detailed protocol is presented in Galloway *et al.* (1987).

Abs= aberrations

^b Solvent control

^c Positive control

^d Significance of percent cells with aberrations tested by the linear regression trend test versus log of the dose

TABLE E5
Induction of Sex-Linked Recessive Lethal Mutations in *Drosophila melanogaster* by Isobutyraldehyde^a

Route of Exposure	Dose (ppm)	Incidence of Death (%)	Incidence of Sterility (%)	No. of Lethals/No. of X Chromosomes Tested			Total ^b
				Mating 1	Mating 2	Mating 3	
Feed	80,000	29	0	0/2,555	0/2,120	4/1,575	4/6,250 (0.06%)
	0			5/3,392	2/2,422	2/1,852	9/7,666 (0.12%)
Injection	50,000	32	8	0/2,272	3/2,035	5/1,858	8/6,165 (0.13%)
	0			0/2,274	2/2,071	3/1,800	5/6,145 (0.08%)

^a Study performed at Bowling Green State University. The detailed protocol and these data are presented in Woodruff *et al.* (1985). Results were not significant at the 5% level (Margolin *et al.*, 1983).

^b Total number of lethal mutations/number of X chromosomes tested for three mating trials

TABLE E6
Induction of Chromosomal Aberrations in Mouse Bone Marrow Cells by Isobutyraldehyde^a

Compound	Dose (mg/kg)	Abs/Cell ^b	Cells with Abs (%)
Trial 1 - Sample time: 17.0			
Corn oil ^c		2.9 ± 0.02	2.25
Dimethylbenzanthracene ^d	100	6.8 ± 0.06	4.75
	200	7.5 ± 0.08	6.50
Isobutyraldehyde	500	1.9 ± 0.02	1.75
	1,000	2.0 ± 0.02	2.25
	1,500	10.5 ± 0.12	9.75
	2,000	Lethal	
Trend test ^e			P < 0.001
Trial 2 - Sample time: 17.0			
Corn oil	1.4	1.4 ± 0.01	1.50
Dimethylbenzanthracene	100	4.0 ± 0.03	3.25
	200	13.5 ± 0.11	7.00
Isobutyraldehyde	1,000	2.9 ± 0.01	1.50
	1,200	2.9 ± 0.02	2.25
	1,500	4.0 ± 0.04	3.14
	1,750	10.6 ± 0.11	8.86
Trend test			P < 0.001

^a Study was performed at Environmental Health Research and Testing, Inc. The detailed protocol is presented in Tice *et al.* (1987).

Abs= aberrations

^b Mean ± standard error

^c Solvent control

^d Positive control

^e Significance tested by one-tailed trend test (Margolin *et al.*, 1986); significant at P ≤ 0.025

TABLE E7
Induction of Micronuclei in Bone Marrow Polychromatic Erythrocytes of Rats and Mice
Treated with Isobutyraldehyde by Intraperitoneal Injection^a

	Dose (mg/kg)	Micronucleated PCEs/1,000 PCEs ^b	Number of Animals with Erythrocytes Scored
Rats			
Corn oil ^c		1.20 ± 0.25	5
Cyclophosphamide ^d	25	45.47 ± 4.53	5
Isobutyraldehyde	312.5	1.10 ± 0.33	5
	625	0.90 ± 0.43	5
	1,250	1.25 ± 0.52	4
		P= 0.479 ^e	
Mice			
Study 1			
Corn oil		1.3 ± 0.3	5
Cyclophosphamide	25	3.0 ± 0.4	5
Isobutyraldehyde	39.06	1.7 ± 0.6	5
	78.13	0.7 ± 0.2	5
	156.25	0.8 ± 0.4	5
	312.5	1.4 ± 0.4	5
	652	1.0 ± 0.3	5
	1,250	1.7 ± 0.5	4
		P= 0.157	
Study 2			
Corn oil		1.0 ± 0.4	5
Cyclophosphamide	25	7.5 ± 1.2	5
Isobutyraldehyde	156.25	2.3 ± 0.5	5
	312.5	1.8 ± 0.6	5
	625	1.8 ± 0.8	5
	1,250	Lethal	5
		P= 0.269	

^a Study was performed at Integrated Laboratory Systems, Inc. The protocol is presented in Shelby *et al.* (1993); PCE= polychromatic erythrocyte.

^b Mean ± standard error

^c Solvent control

^d Positive control

^e Significance of micronucleated PCEs/1,000 PCEs tested by the one-tailed trend test; significant at P≤0.025 (Margolin *et al.*, 1986)

APPENDIX F

ORGAN WEIGHTS AND ORGAN-WEIGHT-TO-BODY-WEIGHT RATIOS

TABLE F1	Organ Weights and Organ-Weight-to-Body-Weight Ratios for Rats in the 13-Week Inhalation Study of Isobutyraldehyde	208
TABLE F2	Organ Weights and Organ-Weight-to-Body-Weight Ratios for Mice in the 13-Week Inhalation Study of Isobutyraldehyde	209

TABLE F1
Organ Weights and Organ-Weight-to-Body-Weight Ratios for Rats in the 13-Week Inhalation Study
of Isobutyraldehyde^a

	Chamber Control	500 ppm	1,000 ppm	2,000 ppm	4,000 ppm
Male					
n	10	10	10	10	7
Necropsy body wt	331 ± 8	340 ± 5	339 ± 7	345 ± 5	293 ± 4**
Brain					
Absolute	1.979 ± 0.013	1.998 ± 0.020	2.044 ± 0.013	1.960 ± 0.091	1.888 ± 0.021
Relative	6.00 ± 0.12	5.87 ± 0.05	6.04 ± 0.10	5.70 ± 0.27	6.44 ± 0.07
Heart					
Absolute	1.144 ± 0.048	1.165 ± 0.030	1.221 ± 0.046	1.298 ± 0.088	1.120 ± 0.056
Relative	3.45 ± 0.10	3.43 ± 0.10	3.59 ± 0.10	3.77 ± 0.25	3.81 ± 0.16
R. Kidney					
Absolute	1.276 ± 0.045	1.315 ± 0.029	1.358 ± 0.029	1.390 ± 0.038	1.258 ± 0.022
Relative	3.85 ± 0.07	3.87 ± 0.07	4.01 ± 0.07	4.03 ± 0.10	4.29 ± 0.04**
Liver					
Absolute	12.534 ± 0.479	13.220 ± 0.313	12.983 ± 0.363	12.664 ± 0.181	11.203 ± 0.161*
Relative	37.76 ± 0.69	38.80 ± 0.45	38.24 ± 0.58	36.77 ± 0.48	38.18 ± 0.22
Lung					
Absolute	1.577 ± 0.069	1.568 ± 0.080	1.588 ± 0.091	1.602 ± 0.074	1.455 ± 0.104
Relative	4.76 ± 0.19	4.61 ± 0.24	4.67 ± 0.22	4.65 ± 0.21	4.94 ± 0.29
R. Testis					
Absolute	1.492 ± 0.024	1.491 ± 0.029	1.494 ± 0.013	1.516 ± 0.011	1.368 ± 0.093
Relative	4.52 ± 0.08	4.38 ± 0.07	4.41 ± 0.07	4.41 ± 0.06	4.65 ± 0.30
Thymus					
Absolute	0.285 ± 0.024	0.291 ± 0.012	0.289 ± 0.017	0.268 ± 0.024	0.211 ± 0.014*
Relative	0.86 ± 0.06	0.86 ± 0.04	0.85 ± 0.04	0.78 ± 0.07	0.72 ± 0.04
Female					
n	10	9	10	10	4
Necropsy body wt	184.4 ± 2.8	192.6 ± 1.8	191.2 ± 3.1	193.2 ± 6.1	176.0 ± 6.4
Brain					
Absolute	1.812 ± 0.022	1.850 ± 0.030	1.836 ± 0.012	1.805 ± 0.030	1.674 ± 0.033*
Relative	9.84 ± 0.14	9.61 ± 0.20	9.62 ± 0.17	9.42 ± 0.30	9.55 ± 0.36
Heart					
Absolute	0.749 ± 0.025	0.826 ± 0.017	0.820 ± 0.023	0.806 ± 0.030	0.717 ± 0.050
Relative	4.06 ± 0.11	4.29 ± 0.08	4.30 ± 0.12	4.19 ± 0.15	4.06 ± 0.15
R. Kidney					
Absolute	0.758 ± 0.021	0.815 ± 0.015	0.805 ± 0.023	0.844 ± 0.028	0.805 ± 0.065
Relative	4.12 ± 0.11	4.23 ± 0.08	4.21 ± 0.12	4.38 ± 0.09	4.56 ± 0.26
Liver					
Absolute	6.446 ± 0.118	6.731 ± 0.136	6.743 ± 0.191	6.821 ± 0.274	6.401 ± 0.234
Relative	35.02 ± 0.77	34.93 ± 0.56	35.24 ± 0.68	35.28 ± 0.74	36.39 ± 0.44
Lung					
Absolute	1.016 ± 0.053	1.029 ± 0.047	1.062 ± 0.054	1.003 ± 0.049	1.150 ± 0.055
Relative	5.50 ± 0.25	5.35 ± 0.26	5.59 ± 0.36	5.22 ± 0.29	6.55 ± 0.34
Thymus					
Absolute	0.244 ± 0.016	0.266 ± 0.016	0.251 ± 0.015	0.246 ± 0.016	0.199 ± 0.021
Relative	1.32 ± 0.09	1.38 ± 0.08	1.31 ± 0.07	1.28 ± 0.08	1.14 ± 0.13

* Significantly different ($P \leq 0.05$) from the chamber control group by Williams' or Dunnett's test

** $P \leq 0.01$

^a Organ weights (absolute weights) and body weights are given in grams; organ-weight-to-body-weight ratios (relative weights) are given as mg organ weight/g body weight (mean ± standard error). All 8,000 ppm rats died before the end of the study.

TABLE F2
Organ Weights and Organ-Weight-to-Body-Weight Ratios for Mice in the 13-Week Inhalation Study of Isobutyraldehyde^a

	Chamber Control	500 ppm	1,000 ppm	2,000 ppm	4,000 ppm
Male					
n	9	10	9	10	1 ^b
Necropsy body wt	27.5 ± 0.7	27.6 ± 0.5	28.2 ± 0.5	27.2 ± 0.5	24.0
Brain					
Absolute	0.481 ± 0.005	0.499 ± 0.006	0.498 ± 0.009	0.474 ± 0.005	0.420
Relative	17.54 ± 0.29	18.12 ± 0.29	17.72 ± 0.47	17.49 ± 0.30	17.50
Heart					
Absolute	0.174 ± 0.007	0.177 ± 0.005	0.194 ± 0.009	0.176 ± 0.010	0.151
Relative	6.32 ± 0.17	6.43 ± 0.17	6.89 ± 0.26	6.47 ± 0.29	6.29
R. Kidney					
Absolute	0.304 ± 0.013	0.342 ± 0.010	0.357 ± 0.011*	0.350 ± 0.013*	0.277
Relative	11.03 ± 0.38	12.40 ± 0.34*	12.68 ± 0.31**	12.89 ± 0.44**	11.54
Liver					
Absolute	1.580 ± 0.053	1.542 ± 0.034	1.644 ± 0.051	1.655 ± 0.054	1.491
Relative	57.37 ± 1.00	55.93 ± 0.95	58.30 ± 1.26	60.79 ± 1.45	62.13
Lung					
Absolute	0.226 ± 0.008	0.243 ± 0.018	0.253 ± 0.012	0.226 ± 0.010	0.161
Relative	8.22 ± 0.23	8.79 ± 0.58	8.98 ± 0.36	8.29 ± 0.27	6.71
R. Testis					
Absolute	0.127 ± 0.004	0.122 ± 0.005	0.129 ± 0.006	0.118 ± 0.003	0.078
Relative	4.66 ± 0.21	4.45 ± 0.23	4.55 ± 0.16	4.35 ± 0.11	3.25
Thymus					
Absolute	0.039 ± 0.002	0.032 ± 0.004	0.033 ± 0.003	0.030 ± 0.003	0.015
Relative	1.41 ± 0.06	1.15 ± 0.12	1.18 ± 0.10	1.11 ± 0.12	0.63
Female					
n	10	10	10	10	
Necropsy body wt	25.9 ± 0.5	24.9 ± 0.6	24.0 ± 0.3*	25.4 ± 0.3	
Brain					
Absolute	0.495 ± 0.004	0.487 ± 0.008	0.494 ± 0.011	0.491 ± 0.009	
Relative	19.15 ± 0.35	19.67 ± 0.52	20.61 ± 0.64	19.34 ± 0.43	
Heart					
Absolute	0.157 ± 0.007	0.152 ± 0.006	0.146 ± 0.004	0.147 ± 0.005	
Relative	6.03 ± 0.21	6.12 ± 0.26	6.07 ± 0.21	5.79 ± 0.14	
R. Kidney					
Absolute	0.222 ± 0.007	0.231 ± 0.009	0.228 ± 0.005	0.241 ± 0.006	
Relative	8.56 ± 0.28	9.28 ± 0.20*	9.49 ± 0.16**	9.46 ± 0.18**	
Liver					
Absolute	1.563 ± 0.028	1.374 ± 0.039**	1.433 ± 0.026*	1.579 ± 0.031	
Relative	60.34 ± 0.84	55.28 ± 0.99**	59.69 ± 1.04	62.09 ± 0.79	
Lung					
Absolute	0.202 ± 0.014	0.207 ± 0.011	0.198 ± 0.010	0.210 ± 0.016	
Relative	7.80 ± 0.54	8.42 ± 0.57	8.28 ± 0.48	8.29 ± 0.67	
Thymus					
Absolute	0.051 ± 0.003	0.052 ± 0.003	0.043 ± 0.002*	0.039 ± 0.002**	
Relative	1.98 ± 0.11	2.08 ± 0.07	1.79 ± 0.08	1.55 ± 0.07**	

* Significantly different ($P \leq 0.05$) from the chamber control group by Williams' or Dunnett's test

** $P \leq 0.01$

^a Organ weights (absolute weights) and body weights are given in grams; organ-weight-to-body-weight ratios (relative weights) are given as mg organ weight/g body weight (mean ± standard error). All 8,000 ppm mice and 4,000 ppm female mice died before the end of the study.

^b No standard error was calculated because fewer than two measurements were available.

APPENDIX G

HEMATOLOGY AND CLINICAL CHEMISTRY RESULTS

TABLE G1	Hematology and Clinical Chemistry Data for Rats in the 13-Week Inhalation Study of Isobutyraldehyde	212
TABLE G2	Hematology Data for Mice in the 13-Week Inhalation Study of Isobutyraldehyde	213

TABLE G1
Hematology and Clinical Chemistry Data for Rats in the 13-Week Inhalation Study of Isobutyraldehyde^a

	Chamber Control	500 ppm	1,000 ppm	2,000 ppm	4,000 ppm
Male					
n	10	10	10	10	7
Hematology					
Hematocrit (%)	48.0 ± 0.5	51.4 ± 2.5	52.2 ± 2.0	46.6 ± 0.6	44.8 ± 1.1
Hemoglobin (g/dL)	15.9 ± 0.2	17.2 ± 0.9	17.4 ± 0.7	15.7 ± 0.2	15.2 ± 0.3
Erythrocytes (10 ⁶ /μL)	9.26 ± 0.10	10.03 ± 0.49	10.10 ± 0.40	9.03 ± 0.11	8.45 ± 0.21*
Reticulocytes (10 ⁶ /μL)	0.06 ± 0.02	0.26 ± 0.03**	0.22 ± 0.03**	0.07 ± 0.01	0.03 ± 0.00
Leukocytes (10 ³ /μL)	6.19 ± 0.26	7.98 ± 0.55	7.79 ± 0.56	6.11 ± 0.41	6.46 ± 0.68
Segmented neutrophils (10 ³ /μL)	0.95 ± 0.05	1.38 ± 0.15*	1.59 ± 0.14**	1.05 ± 0.11	1.57 ± 0.13**
Lymphocytes (10 ³ /μL)	5.03 ± 0.24	6.44 ± 0.46	6.07 ± 0.50	4.89 ± 0.34	4.78 ± 0.58
Monocytes (10 ³ /μL)	0.13 ± 0.02	0.04 ± 0.02*	0.04 ± 0.02*	0.09 ± 0.03	0.05 ± 0.03
Eosinophils (10 ³ /μL)	0.09 ± 0.02	0.12 ± 0.02	0.09 ± 0.03	0.08 ± 0.02	0.06 ± 0.03
Clinical Chemistry					
Urea nitrogen (mg/dL)	21.7 ± 0.5	21.4 ± 0.3	21.4 ± 0.4	22.6 ± 0.6	19.4 ± 0.4*
Alanine aminotransferase (IU/L)	32 ± 1	37 ± 2*	41 ± 2**	49 ± 2**	47 ± 1**
Aspartate aminotransferase (IU/L)	104 ± 4	81 ± 2**	91 ± 4	95 ± 6	89 ± 7
Sorbitol dehydrogenase (IU/L)	20 ± 1	21 ± 1	21 ± 1	22 ± 2	18 ± 1
Female					
n	10	9	10	10	4
Hematology					
Hematocrit (%)	47.6 ± 0.8	50.8 ± 1.9	51.5 ± 2.5	47.1 ± 0.7	46.7 ± 0.8
Hemoglobin (g/dL)	15.8 ± 0.2	16.7 ± 0.6	16.9 ± 0.8	15.7 ± 0.2	15.6 ± 0.2
Erythrocytes (10 ⁶ /μL)	8.82 ± 0.14	9.38 ± 0.33	9.47 ± 0.47	8.67 ± 0.13	8.73 ± 0.13
Reticulocytes (10 ⁶ /μL)	0.13 ± 0.03	0.18 ± 0.03	0.19 ± 0.02	0.03 ± 0.01**	0.03 ± 0.01*
Leukocytes (10 ³ /μL)	6.50 ± 0.22	6.47 ± 0.57	5.70 ± 0.43	5.10 ± 0.39	6.40 ± 0.67 ^b
Segmented neutrophils (10 ³ /μL)	0.94 ± 0.09	1.40 ± 0.19	1.03 ± 0.10	1.09 ± 0.15	1.54 ± 0.40 ^b
Lymphocytes (10 ³ /μL)	5.41 ± 0.21	4.94 ± 0.44	4.50 ± 0.39*	3.92 ± 0.29**	4.71 ± 0.66 ^b
Monocytes (10 ³ /μL)	0.07 ± 0.04	0.04 ± 0.01	0.06 ± 0.02	0.06 ± 0.01	0.04 ± 0.02 ^b
Eosinophils (10 ³ /μL)	0.08 ± 0.04	0.08 ± 0.03	0.11 ± 0.03	0.03 ± 0.01	0.10 ± 0.02 ^b
Clinical Chemistry					
Urea nitrogen (mg/dL)	23.5 ± 0.7	24.4 ± 0.9	23.1 ± 0.5	23.5 ± 0.5	23.3 ± 1.1
Alanine aminotransferase (IU/L)	31 ± 2	38 ± 2*	40 ± 1**	42 ± 2**	49 ± 2**
Aspartate aminotransferase (IU/L)	112 ± 6	99 ± 4	91 ± 2**	101 ± 6	93 ± 4
Sorbitol dehydrogenase (IU/L)	21 ± 1	23 ± 1	21 ± 1	23 ± 1	20 ± 1

* Significantly different ($P \leq 0.05$) from the chamber control group by Dunn's or Shirley's test

** $P \leq 0.01$

^a Mean ± standard error. Statistical tests were performed on unrounded data. All 8,000 ppm rats died before the end of the study.

^b n = 3

TABLE G2
Hematology Data for Mice in the 13-Week Inhalation Study of Isobutyraldehyde^a

	Chamber Control	500 ppm	1,000 ppm	2,000 ppm	4,000 ppm
Male					
n	9	10	9	10	1 ^b
Hematocrit (%)	48.4 ± 0.6	45.2 ± 1.5	49.6 ± 0.7	48.7 ± 0.7	45.2
Hemoglobin (g/dL)	15.6 ± 0.1	14.1 ± 0.5*	15.7 ± 0.3	15.4 ± 0.3	14.8
Erythrocytes (10 ⁶ /μL)	9.41 ± 0.12	9.09 ± 0.40	10.17 ± 0.22	9.86 ± 0.27	9.62
Reticulocytes (10 ³ /μL)	0.06 ± 0.01	0.12 ± 0.02*	0.10 ± 0.02	0.13 ± 0.01**	0.04
Leukocytes (10 ³ /μL)	4.00 ± 0.40	4.81 ± 0.57	3.68 ± 0.35	4.02 ± 0.38	5.00
Segmented neutrophils (10 ³ /μL)	0.91 ± 0.13	0.85 ± 0.15 ^c	0.58 ± 0.12	0.58 ± 0.07 ^c	1.35
Lymphocytes (10 ³ /μL)	3.01 ± 0.31	3.68 ± 0.36	3.07 ± 0.30	3.18 ± 0.30	3.40
Monocytes (10 ³ /μL)	0.04 ± 0.02	0.03 ± 0.01	0.02 ± 0.01	0.05 ± 0.01	0.05
Eosinophils (10 ³ /μL)	0.04 ± 0.01	0.02 ± 0.01	0.00 ± 0.00	0.09 ± 0.02	0.20
Female					
n	10	10	10	10	
Hematocrit (%)	47.7 ± 0.6	50.1 ± 0.5*	50.1 ± 0.4*	46.2 ± 1.6	
Hemoglobin (g/dL)	15.3 ± 0.2	15.8 ± 0.2	15.8 ± 0.1	14.9 ± 0.5	
Erythrocytes (10 ⁶ /μL)	9.27 ± 0.11	10.39 ± 0.11**	10.35 ± 0.10**	9.57 ± 0.32	
Reticulocytes (10 ³ /μL)	0.06 ± 0.02	0.06 ± 0.01	0.06 ± 0.00	0.09 ± 0.01**	
Leukocytes (10 ³ /μL)	3.93 ± 0.27	3.91 ± 0.18	4.52 ± 0.22	3.45 ± 0.37	
Segmented neutrophils (10 ³ /μL)	0.82 ± 0.15	0.60 ± 0.05	0.66 ± 0.07	0.68 ± 0.12	
Lymphocytes (10 ³ /μL)	3.03 ± 0.15	3.27 ± 0.16	3.75 ± 0.15*	2.66 ± 0.25	
Monocytes (10 ³ /μL)	0.03 ± 0.01	0.03 ± 0.01	0.01 ± 0.01	0.06 ± 0.01	
Eosinophils (10 ³ /μL)	0.05 ± 0.02	0.01 ± 0.01	0.09 ± 0.03	0.05 ± 0.01	

* Significantly different ($P \leq 0.05$) from the chamber control group by Dunn's or Shirley's test

** $P \leq 0.01$

^a Mean ± standard error. Statistical tests were performed on unrounded data. All 8,000 ppm mice and 4,000 ppm female mice died before the end of the study.

^b No standard error was calculated because fewer than two measurements were available.

^c n=9

APPENDIX H

REPRODUCTIVE TISSUE EVALUATIONS AND ESTROUS CYCLE CHARACTERIZATION

TABLE H1	Summary of Reproductive Tissue Evaluations and Estrous Cycle Characterization for Rats in the 13-Week Inhalation Study of Isobutyraldehyde	216
TABLE H2	Summary of Reproductive Tissue Evaluations and Estrous Cycle Characterization for Mice in the 13-Week Inhalation Study of Isobutyraldehyde	217

TABLE H1
Summary of Reproductive Tissue Evaluations and Estrous Cycle Characterization for Rats
in the 13-Week Inhalation Study of Isobutyraldehyde^a

	Chamber Control	500 ppm	1,000 ppm	2,000 ppm	4,000 ppm
Male					
n	10	10	10	10	7
Weights (g)					
Necropsy body wt	331 ± 8	340 ± 5	339 ± 7	345 ± 5	293 ± 4**
R. cauda	0.1962 ± 0.0056	0.1921 ± 0.0065	0.1867 ± 0.0082	0.1886 ± 0.0096	0.1517 ± 0.0107**
R. epididymis	0.5708 ± 0.0164	0.5441 ± 0.0162	0.5234 ± 0.0141	0.5460 ± 0.0134	0.4565 ± 0.0254** ^b
R. testis	1.492 ± 0.024	1.494 ± 0.013	1.516 ± 0.011	1.368 ± 0.093	
Epididymal spermatozoal parameters					
Motility (%)	78.00 ± 6.45	17.30 ± 3.09**	19.60 ± 4.47**	79.80 ± 6.03	64.43 ± 12.61
Abnormal (%)	1.40 ± 0.24	1.62 ± 0.30	1.28 ± 0.15	1.46 ± 0.29	2.00 ± 0.30 ^b
Concentration (10 ⁶ /g cauda epididymal tissue)	348 ± 60	321 ± 53	433 ± 71	342 ± 54	293 ± 95
Female					
n	10	10	9	10	4
Necropsy body wt (g)	184 ± 3	193 ± 2 ^c	191 ± 3 ^d	193 ± 6	176 ± 6
Estrous cycle length (days)	5.00 ± 0.15	5.00 ± 0.00	5.00 ± 0.17	4.90 ± 0.23	5.33 ± 0.33 ^e
Estrous stages ^f (% of cycle)					
Diestrus	20.0	18.6	23.8	21.4	32.1
Proestrus	18.6	11.4	12.7	17.1	0.0
Estrus	30.0	32.9	22.2	25.7	32.1
Metestrus	30.0	37.1	41.3	34.3	35.7
Uncertain diagnoses	1.4	0.0	0.0	1.4	0.0

** Significantly different ($P \leq 0.01$) from the chamber control group by Williams' or Dunnett's test (body and tissue weights) or by Dunn's test (motility)

^a Weights, epididymal spermatozoal parameters, and estrous cycle lengths are presented as mean ± standard error. Differences from the chamber control group for epididymal spermatozoal abnormality and concentration and estrous cycle length are not significant by Dunn's test.

^b n= 6

^c n= 9

^d n= 10

^e Estrous cycle was longer than 12 days or unclear in one of four animals.

^f Evidence shows that females exposed to 4,000 ppm differ significantly (Wilk's Criterion, $P \leq 0.05$) from the chamber control females in the relative length of time spent in the estrous stages; exposed females spent more time in diestrus and less time in proestrus than chamber control females.

TABLE H2
Summary of Reproductive Tissue Evaluations and Estrous Cycle Characterization for Mice
in the 13-Week Inhalation Study of Isobutyraldehyde^a

	Chamber Control	500 ppm	1,000 ppm	2,000 ppm	4,000 ppm
Male					
n	9	10	9	10	1 ^b
Weights (g)					
Necropsy body wt	27.5 ± 0.7	27.6 ± 0.5	28.2 ± 0.5	27.2 ± 0.5	24.0
R. cauda	0.0176 ± 0.0019	0.0176 ± 0.0014	0.0168 ± 0.0009	0.0164 ± 0.0016	0.0080
R. epididymis	0.0561 ± 0.0047	0.0597 ± 0.0038 ^c	0.0550 ± 0.0048	0.0579 ± 0.0044	0.0430
R. testis	0.127 ± 0.004	0.129 ± 0.006	0.118 ± 0.003	0.078	
Epididymal spermatozoal parameters					
Motility (%)	31.67 ± 3.95	43.50 ± 8.09	35.78 ± 5.02	37.30 ± 4.38	46.00
Abnormal (%)	1.67 ± 0.16	2.60 ± 1.06	1.27 ± 0.15	1.56 ± 0.15	10.80
Concentration (10 ⁶ /g cauda epididymal tissue)	700 ± 131	695 ± 55	573 ± 76	707 ± 100	625
Female					
n	10	10	10	10	
Necropsy body wt (g)	25.9 ± 0.5	24.9 ± 0.6	24.0 ± 0.3*	25.4 ± 0.3	
Estrous cycle length (days)	5.14 ± 0.26 ^d	5.13 ± 0.48 ^e	5.38 ± 0.18 ^e	5.50 ± 0.22 ^f	
Estrous stages (% of cycle)					
Diestrus	28.6	24.3	17.1	22.9	
Proestrus	14.3	15.7	11.4	10.0	
Estrus	32.9	40.0	52.9	38.6	
Metestrus	24.3	18.6	18.6	28.6	
Uncertain diagnoses	0.0	1.4	0.0	0.0	

* Significantly different ($P \leq 0.05$) from the control group by Dunnett's test

^a Weights, epididymal spermatozoal parameters, and estrous cycle lengths are presented as mean ± standard error. Differences from the chamber control group for tissue weights are not significant by Dunnett's test; differences from the control group for epididymal spermatozoal parameters and estrous cycle length are not significant by Dunn's test. By multivariate analysis of variance, exposed females do not differ significantly from the chamber control females in the relative length of time spent in the estrous stages.

^b No standard error was calculated because fewer than two measurements were available.

^c n=9

^d Estrous cycle was longer than 12 days or unclear in 3 of 10 animals.

^e Estrous cycle was longer than 12 days or unclear in 2 of 10 animals.

^f Estrous cycle was longer than 12 days or unclear in 4 of 10 animals.

APPENDIX I

CHEMICAL CHARACTERIZATION AND GENERATION OF CHAMBER CONCENTRATIONS

PROCUREMENT AND CHARACTERIZATION OF ISOBUTYRALDEHYDE	220
VAPOR GENERATION AND EXPOSURE SYSTEM	221
VAPOR CONCENTRATION MONITORING	223
CHAMBER ATMOSPHERE CHARACTERIZATION	223
FIGURE I1 Infrared Absorption Spectrum of Isobutyraldehyde	226
FIGURE I2 Nuclear Magnetic Resonance Spectrum of Isobutyraldehyde	227
FIGURE I3 Schematic of Generation and Delivery System for the 13-Week Studies	228
FIGURE I4 Schematic of Generation and Delivery System for the 2-Year Studies	229
TABLE I1 Summary of Chamber Concentrations in the 13-Week Inhalation Studies of Isobutyraldehyde	230
TABLE I2 Summary of Chamber Concentrations in the 2-Year Inhalation Studies of Isobutyraldehyde	230

CHEMICAL CHARACTERIZATION AND GENERATION OF CHAMBER CONCENTRATIONS

PROCUREMENT AND CHARACTERIZATION OF ISOBUTYRALDEHYDE

Isobutyraldehyde was obtained from Eastman Chemical Company (Tennessee Eastman Division, Kingsport, TN, and Texas Eastman Division, Longview, TX) in three lots. Lots 56-202 and E042283, supplied by Tennessee Eastman Division, were used during the 13-week studies. Lot E080289, supplied by Texas Eastman Division, was used during the 2-year studies. Identity, purity, and stability analyses were conducted by the analytical chemistry laboratory, Midwest Research Institute (Kansas City, MO). Reports on analyses performed in support of the isobutyraldehyde studies are on file at the National Institute of Environmental Health Sciences.

All lots of the chemical, a clear, colorless, nonviscous liquid, were identified as isobutyraldehyde by infrared, ultraviolet/visible, and nuclear magnetic resonance spectroscopy. The infrared and nuclear magnetic resonance spectra were consistent with the literature spectra (*Sadtler Standard Spectra*) of isobutyraldehyde. The ultraviolet/visible spectra were consistent with the structure of isobutyraldehyde. The infrared and nuclear magnetic spectra are presented in Figures I1 and I2. For lot 56-202, the boiling point and density were consistent with literature references (*Patty's*, 1982; *Merck Index*, 1989). For lot E080289, the density was consistent with lot 56-202 and with a literature reference (*Merck Index*, 1989), but the boiling point was lower than that of lot 56-202 and one literature reference (*Patty's*, 1982) and higher than another literature reference (*Merck Index*, 1989).

The purity of each lot was determined by elemental analyses, Karl Fischer water analysis, oximation and free acid titration, and gas chromatography. Oximation titration was performed by reacting samples of isobutyraldehyde with hydroxylamine hydrochloride in the presence of triethanolamine for 60 minutes (lots 56-202 and E080289) or 30, 60, and 120 minutes (lot E042283) and at room temperature. The excess triethanolamine was then titrated with 0.5 N sulfuric acid to a pH of 3.4 (lot 56-202) or to a potentiometric endpoint (lots E042283 and E080289). Free acid titration was performed by dissolving samples of isobutyraldehyde in methanol under a nitrogen headspace (lots 56-202 and E042283) or under an argon headspace (lot E080289). Samples were titrated to the phenolphthalein endpoint with 0.1 N alcoholic potassium hydroxide. The oximation titration of lots 56-202 and E042283 and both titrations of lot E080289 were monitored with a combination pH/mV electrode, which was filled with 3 M potassium chloride for lots E042283 and E080289. Gas chromatography was performed using a flame ionization detector with a nitrogen carrier gas at a flow rate of 70 mL/minute. Two systems were used:

- A) 80/100 Poropak QS glass column, with an oven temperature program of 50° C for 5 minutes, then 50° to 200° C at 10° C per minute, and
- B) 20% SP-2100/0.1% Carbowax 1500 on 100/120 Supelcoport glass column, with an oven temperature program of 50° C for 5 minutes, then 50° to 170° C at 10° C per minute.

For lot 56-202, elemental analyses for carbon and hydrogen were in agreement with the theoretical values for isobutyraldehyde. Karl Fischer water analysis indicated 0.11% ± 0.01% water. Functional group titration for oximation indicated a purity of 102.0% ± 0.9%, and functional group titration for free acid indicated a concentration of 0.375% ± 0.008% isobutyric acid (a common oxidation product of isobutyraldehyde). Gas chromatography of lot 56-202 using system A indicated one major peak and three impurities with areas greater than 0.1% of the major peak area. Two impurities had a combined area of 0.20% relative to the major peak area; the third impurity had an area of 0.46% relative to the major peak

area and was identified as isobutyric acid by spiking with a standard solution of isobutyric acid in toluene. Gas chromatography using system B indicated one major peak and four impurities with areas greater than 0.1% of the major peak area. One impurity had an area of 0.29% relative to the major peak area; the remaining three impurities had a combined area of 0.57% relative to the major peak area. The overall purity of lot 56-202 was determined to be approximately 99%.

For lot E042283, elemental analyses for carbon and hydrogen were in agreement with the theoretical values for isobutyraldehyde. Karl Fischer water analysis indicated $0.084\% \pm 0.007\%$ water. Functional group titration for oximation indicated a purity of $99.1\% \pm 0.9\%$, and functional group titration for free acid indicated a concentration of $0.32\% \pm 0.01\%$ isobutyric acid. Gas chromatography of lot E042283 using system A indicated one major peak and four impurities with areas greater than 0.1% of the major peak area; the total area of the impurities was 0.68% relative to the major peak area. Gas chromatography using system B indicated one major peak and three impurities with a total area of 0.63% relative to the major peak area. The overall purity of lot E042283 was determined to be approximately 99%.

For lot E080289, elemental analysis for hydrogen was in agreement with the theoretical value for isobutyraldehyde; the results for carbon were slightly low. Karl Fischer water analysis indicated $0.06\% \pm 0.01\%$ water. Oximation titration indicated a purity of $98.6\% \pm 0.5\%$, and functional group titration for free acid concentration indicated a concentration of $0.79\% \pm 0.04\%$ isobutyric acid. Gas chromatography of lot E080289 using system A indicated one major peak and two impurities with a combined area of 0.7% relative to the major peak area. Gas chromatography of lot E080289 using system B indicated one major peak and five impurities with combined area of 1.4% relative to the major peak area. The overall purity of lot E080289 was determined to be approximately 98%.

Analysis for free isobutyric acid was conducted by the analytical chemical laboratory with gas chromatography. Lot 56-202 was analyzed by system A but with an isothermal oven temperature of 200°C and with standard solutions of isobutyric acid in toluene as the solvent. The content of isobutyric acid in lot 56-202 was $0.53\% \pm 0.04\%$. Lot E042283 was analyzed on a 10% SP-1200/1.0% phosphoric acid on 10/100 Chromosorb WAW glass column, with an oven temperature program of 90°C for 4 minutes, then 90° to 140°C at 10°C per minute with valeric acid as the internal standard. The content of isobutyric acid in lot E042283 was $0.70\% \pm 0.02\%$. Lot E080289 was analyzed using the system described for lot E042283, but with an 80/100 glass column. The content of isobutyric acid in lot E080289 was $1.40\% \pm 0.04\%$.

Stability studies of the bulk chemical were performed by the analytical chemistry laboratory. Gas chromatography was performed using system A but with an isothermal oven temperature of 50°C and with heptane added as an internal standard. These studies indicated that isobutyraldehyde was stable as a bulk chemical for 2 weeks when stored under a nitrogen headspace, protected from light, at temperatures up to 25°C . To ensure stability, the bulk chemical was stored at 4°C (13-week studies) or at room temperature (2-year studies) in the original containers under a nitrogen headspace. Stability was monitored throughout the 13-week and 2-year studies using titration of acidic compounds and gas chromatography with system B. No degradation of the bulk chemical was detected.

VAPOR GENERATION AND EXPOSURE SYSTEM

A diagram of the isobutyraldehyde generation and delivery system for the 13-week studies is shown in Figure I3. Because isobutyraldehyde is a liquid with a high vapor pressure at room temperature (170 mm Hg at 20°C), is highly flammable, and has a low flash point (*Patty's*, 1982), the exposure chamber concentrations for the 13-week studies were generated by bubbling nitrogen gas through a column of the liquid maintained at a constant temperature (44° to 46°C) in a water bath. The bubbler used was a gas wash bottle bubbler (PGC Scientific) with a 90-mm-diameter fritted disc of medium porosity at the

bottom. Nitrogen gas was pumped from a reservoir (the original container) through the disc at a constant rate and filtered through approximately 1 L of isobutyraldehyde liquid. An explosion-proof fluid metering pump was used to pump the isobutyraldehyde. During the 13-week studies, the bubbler was continuously refilled via a side tube and pressure stopcock to maintain a constant isobutyraldehyde liquid level in the bubbler. Because isobutyraldehyde reacted with the copper tubing during the flawed 14-day study, the system was redesigned for the 13-week studies. The copper tubing was replaced with stainless steel valves, connections, and tubing, and dilution air was added to the nitrogen-borne isobutyraldehyde vapor immediately above the bubbler to prevent condensation of isobutyraldehyde in the manifold or delivery lines when it cooled to room temperature. The vapor was then further diluted with HEPA- and charcoal-filtered air from intake lines at the top of the chambers. Concentrations of isobutyraldehyde vapor were adjusted for the individual exposure chambers by altering either the nitrogen flow rate, the exposure chamber air flow rate, or the water bath temperature. Isobutyraldehyde vapor was transferred into exposure chambers with fine metering valves (NUPRO).

Inhalation chambers of the Rochester design were used in the 13-week studies. The total volume for each chamber was 1.15 m³. The chamber ventilation system provided 12 to 15 charcoal- and HEPA-filtered air changes per hour and the internal design of the chamber afforded opportunity for equal exposure to each animal. The flow rate was sufficient to maintain the temperature and humidity, to provide a uniform and reproducible test atmosphere, and to remove ammonia. Flow meters were calibrated with regard to pressure drop.

A diagram of the isobutyraldehyde generation and delivery system for the 2-year studies is shown in Figure I4. Isobutyraldehyde vapor was generated with a rotary evaporation system (Büchi Rotavapor, Model EL-131S, Büchi Laboratoriums Technik AG, Flawil, Switzerland). Isobutyraldehyde was pumped from the stainless steel bulk reservoir by a liquid metering pump into a rotating flask that was partially immersed in a hot water bath. Isobutyraldehyde vapor passed from the flask into a chilled water condenser in which much of the vapor condensed and returned to the evaporator flask. Uncondensed vapor was carried to the top of the condenser column by a metered stream of nitrogen. Vapor temperature was monitored at the top of the condensing column by a temperature sensor. The saturation vapor pressure at the column exit temperature was calculated and used to determine the output (concentration of isobutyraldehyde and flow rate of saturated nitrogen) of the generator.

From the condensing column, the vapor entered a short distribution manifold from which individual stainless steel delivery lines carried metered amounts of vapor to each exposure chamber. Flow to each chamber was regulated by compressed air-driven vacuum pumps located at the chamber end of each delivery line. Within the generator cabinet, each delivery line was connected to the distribution manifold through a fine metering valve and flowmeter. Chamber concentration was adjusted by the metering valve and by adjustment of the pressure of compressed air to the vacuum pump.

A three-way valve, mounted in the line between the distribution manifold and each chamber, directed vapor to the exposure chamber exhaust until the generation system was stable. When equilibrium was reached, each valve was opened to allow the flow of vapor into the chamber. At each chamber location, the vapor was injected into the chamber inlet duct, where it was further diluted with charcoal- and HEPA-filtered chamber air to achieve the desired exposure concentration.

The study laboratory designed the stainless-steel chambers used for the 2-year studies (Hazleton 2000, Aberdeen, MD) so that uniform vapor concentrations could be maintained throughout the chamber when catch pans were in position. The total volume for each chamber was 2.3 m³; the active mixing volume of each chamber was 1.7 m³. A small particle detector (Type CN, Gardner Associates, Schenectady, NY) was used with and without animals in the exposure chambers to ensure that isobutyraldehyde vapor, and not

aerosol, was produced. No particle counts above the minimum resolvable level (approximately 200 particles/cm³) were detected.

VAPOR CONCENTRATION MONITORING

The chamber concentrations of isobutyraldehyde in the 13-week studies were monitored on a Wilkes Model 80 infrared spectrophotometer. Samples were drawn and analyzed from each exposure chamber, the control chamber, and the exposure suite 6 to 14 times per exposure period during the 13-week studies. Samples were drawn through Teflon® tubing. A closed-loop calibration of the infrared spectrophotometer was conducted by metering known quantities of isobutyraldehyde over the ranges of interest of 250 ppm to 2,000 ppm (low range) and 1,500 ppm to 10,000 ppm (high range). Thus, the two lowest exposure concentrations were monitored on the lower calibration, the two highest exposure concentrations were monitored on the high calibration, and the middle exposure concentration could be monitored on either.

Chamber concentrations of isobutyraldehyde in the 2-year study were monitored with an on-line gas chromatograph (Hewlett-Packard Model 5840, Palo Alto, CA), using a flame ionization detector and a Poropak PS 80/100 mesh glass column. Samples were drawn and analyzed from each exposure chamber four times per hour using an 8-port stream-select valve.

Calibration of the gas chromatograph monitoring the exposure chamber was achieved by independent quantitative analysis of grab samples collected with bubblers containing dimethylformamide and an internal standard. Additionally, the gas chromatograph was calibrated by a comparison of grab samples and gravimetrically prepared standards with an off-line gas chromatograph. The volumes of gas were sampled at a constant flow rate ensured by a calibrated critical orifice. The off-line gas chromatograph was calibrated with gravimetrically prepared standards of isobutyraldehyde in dimethylformamide.

Summaries of the chamber concentrations during the studies are presented in Tables I1 and I2.

CHAMBER ATMOSPHERE CHARACTERIZATION

The times for the exposure concentrations to build up to 90% of the final exposure concentrations (T_{90}) and to decay to 10% of the exposure concentrations (T_{10}) were measured in the 2-year studies with and without animals present in the chambers. At a chamber airflow rate of 15 air changes per hour, the theoretical value for both T_{90} and T_{10} is approximately 12 to 13 minutes; the T_{90} value chosen for all studies was 12 minutes. Actual T_{90} values were 8 minutes (rats) or 10 to 12 minutes (mice) without animals and 10 minutes (rats) or 9 to 11 minutes (mice) with animals in the chambers. T_{10} values were 9 minutes (rats) or 9 to 11 minutes (mice) without animals and ranged from 10 to 11 minutes (rats) or 7 to 12 minutes (mice) with animals in the chambers.

The uniformity of isobutyraldehyde concentrations in the exposure chambers was measured before the 2-year studies began and approximately every 3 months during the 2-year studies. The concentration was measured with and without animals present using the on-line gas chromatograph with the automatic 12-port sample valve disabled to allow continuous monitoring from a single input line. Uniformity of exposure concentrations in all chambers was acceptable.

The persistence of isobutyraldehyde in the 2,000 ppm exposure chamber after shutting off the system was monitored during the 2-year studies, with and without animals present. The concentration of isobutyraldehyde in the exposure chambers fell to less than 1% of the beginning concentration within 24 minutes without animals present; with animals present, the time to decay to less than 1% of the initial concentration ranged from 22 to 28 minutes for rats and 24 to 26 minutes for mice.

During the 13-week studies, generator reservoir and exposure chamber samples were monitored for isobutyric acid by gas chromatography. By determination of peak area ratios, the average percent isobutyric acid to isobutyraldehyde was 1.16% pregeneration and 2.54% postgeneration. Gas chromatography of postgeneration isobutyraldehyde samples with an internal standard of isobutyric acid revealed an isobutyric acid content of 7% to 12% in the reservoir. Chamber samples were drawn from the 500 and 4,000 ppm chambers and analyzed using gas chromatography with an internal isobutyraldehyde:isobutyric acid standard; samples drawn on 2 days had no measurable amount of acid (less than 0.4% to 0.6% isobutyric acid/aldehyde).

Before the 2-year studies began, the analytical chemistry laboratory tested the vapor stability of lot MH3821JH (not used for animal exposures). Isobutyraldehyde samples collected at 0, 1, 4, 8, and 24 hours and isobutyraldehyde:isobutyric acid standards were injected in a gas chromatographic system for direct headspace analysis. Additional samples were dissolved in toluene and analyzed by gas chromatography. Results indicated less than 10% decomposition of isobutyraldehyde samples exposed for 4 hours to air and light; samples stored open to air and light for up to 24 hours showed a 35% to 40% loss of isobutyraldehyde, with approximately 15% accounted for as isobutyric acid.

During the 2-year studies, isobutyraldehyde again was monitored for stability in the generator reservoir, generator evaporation flask, and exposure chambers by gas chromatography. A sample that remained in the generator reservoir for 7 days had a relative purity of 101% compared to a sample drawn from the reservoir immediately after it had been filled. By major peak comparison, the relative purity of the isobutyraldehyde in the generator flask at the end of the exposure day was determined to be 82.7% when compared to the material drawn from the generator flask at the beginning of the exposure day. Because isobutyraldehyde readily polymerizes to trimers, isobutyraldehyde samples were analyzed for polymers by gas chromatography/mass spectrometry. The percentage of polymer in the generator flask at the beginning of the exposure day was determined to be 0.4%; at the end of the day, 5.9% polymer was found in the generator flask. No polymers were found in the distribution lines or in the 500 ppm or 2,000 ppm chambers before or after the exposure day.

Volatile degradation products and semivolatile impurities in the generator reservoir and exposure chambers in the 2-year studies were monitored with gas chromatography. Samples of isobutyraldehyde were collected from the generator reservoir at the beginning and end of the exposure day. Within the first and last hours of generation, atmosphere samples were collected from the 500 ppm and 2,000 ppm exposure chambers with a gas-tight syringe. Volumetric standards of methane, propane, butane, *n*-butyraldehyde, propionaldehyde, 2,3-dimethylbutane, isobutanol, *n*-butanol, and isobutyraldehyde were prepared for comparison with the generator flask and chamber samples. Methane, propionaldehyde, and four unknown impurities were detected in various exposure system samples. Methane and propionaldehyde were detected in all generator flask samples and in the exposure chamber samples. The highest level of methane, 0.5% by peak area relative to that of isobutyraldehyde, was detected in the 500 ppm exposure chamber at the beginning of the exposure day; at the end of the exposure day, 0.09% was detected in the 500 ppm exposure chamber. One of the four unknown impurities was present at 0.3% by relative area in the reservoir at the end of the day. All other measurements of known and unknown impurities were less than 0.1% by relative area in all samples.

With an on-column injection gas chromatographic method, the presence of trace amounts of contaminants or degradation products was investigated in samples from the 500 ppm and 2,000 ppm exposure chambers, distribution lines, and the generator reservoir. Standard solutions containing 2,3-dimethylbutane, propionaldehyde, isobutyraldehyde, butyraldehyde, 2-propanol, 2-butanol, isobutyl isobutyrate, and 1-butanol and the samples were analyzed. Propionaldehyde, butyraldehyde, and an unidentified impurity were detected in samples from the generator reservoir and from the distribution lines. No impurities were noted in the 500 ppm or 2,000 ppm chamber samples.

The concentration of isobutyric acid was analyzed with gas chromatography/mass spectroscopy. Samples from the bulk chemical, evaporation flask, 500 and 2,000 ppm chambers, and distribution lines were analyzed. The mass spectrometer was operated in the selected ion mode with quantitation of isobutyric acid performed on the extracted ion chromatogram of m/z 43. The amount of isobutyric acid in the bulk material was 0.13% by weight as compared to isobutyraldehyde. The amount of isobutyric acid in the generation flask before exposure was 0.24% that of isobutyraldehyde by weight; after 6 hours of exposure, the concentration was 1.15% compared to isobutyraldehyde by weight. No isobutyric acid was detected in the distribution lines or in the exposure chambers; based on detection limits, the amount of isobutyric acid was less than 0.02% the amount of isobutyraldehyde in the distribution lines, less than 0.7% in the 500 ppm chambers, and less than 0.6% in the 2,000 ppm chambers.

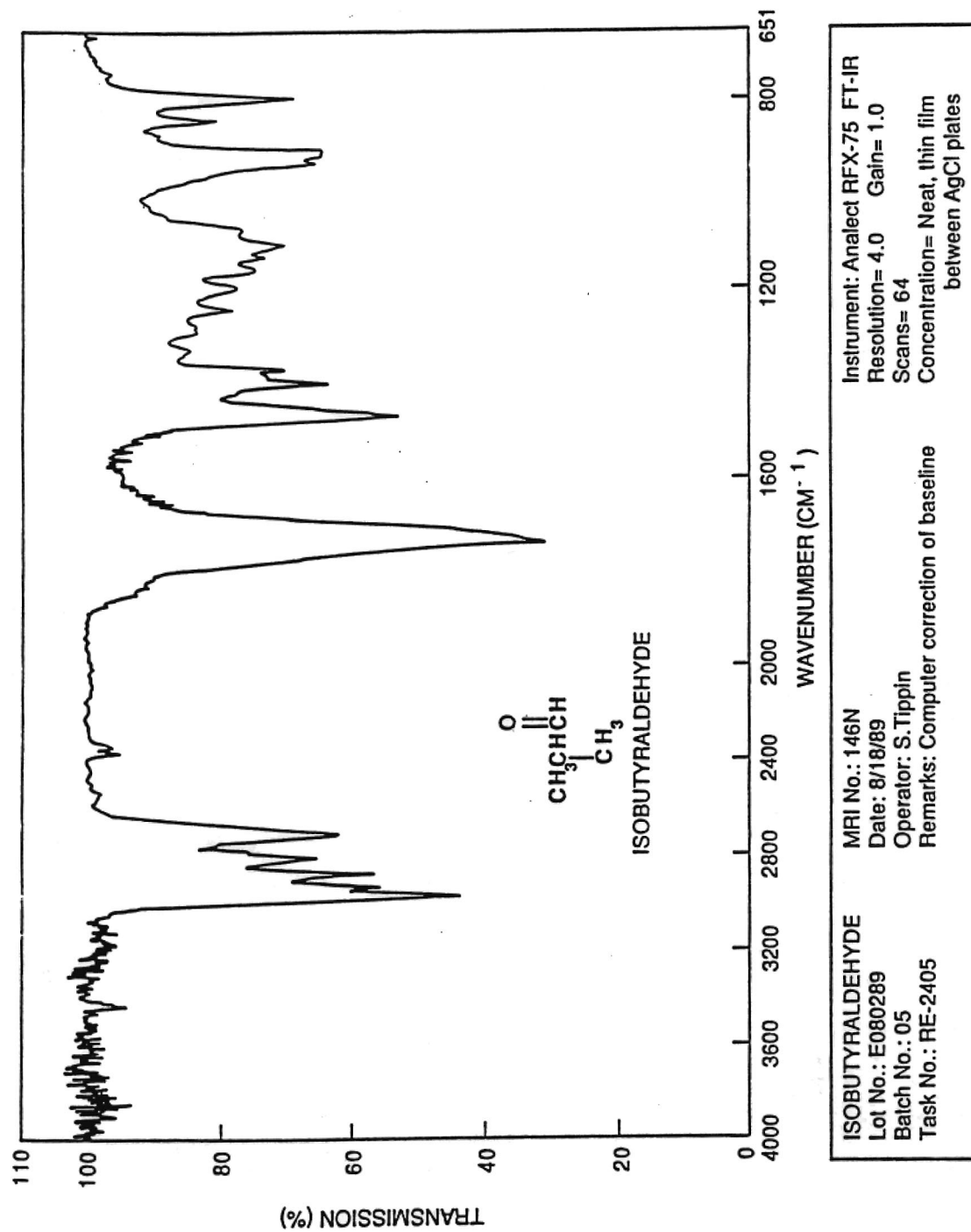

FIGURE II
Infrared Absorption Spectrum of Isobutyraldehyde

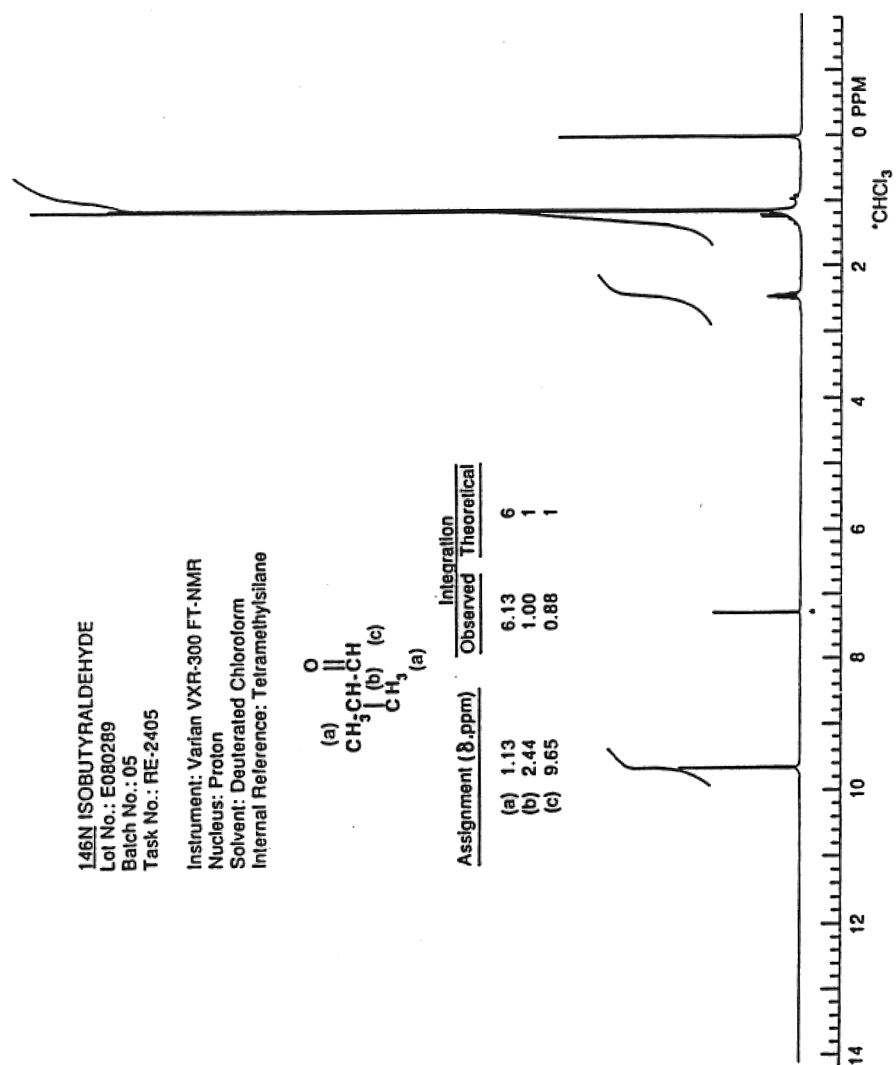

FIGURE I2
 Nuclear Magnetic Resonance Spectrum of Isobutyraldehyde

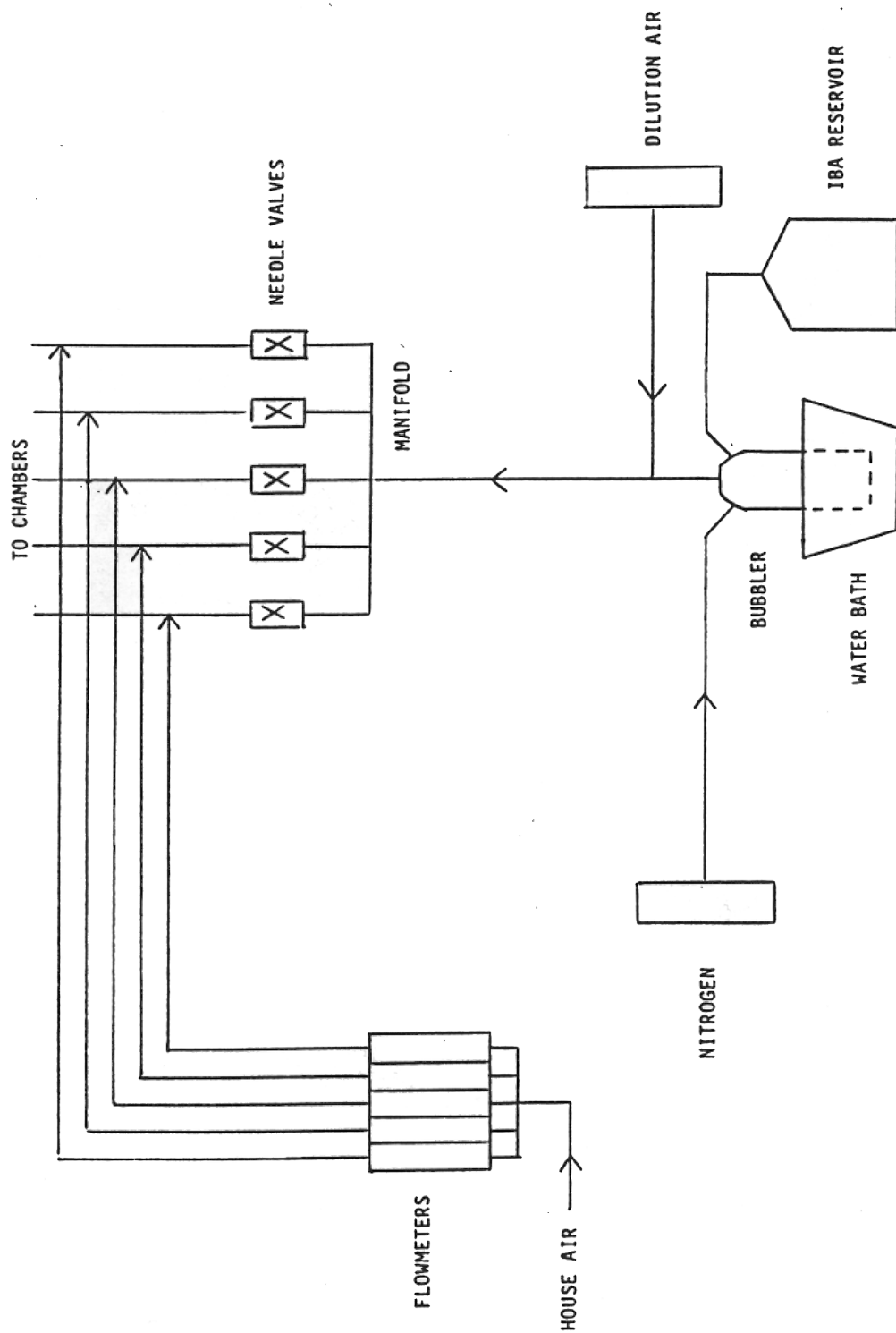

FIGURE I3
Schematic of Generation and Delivery System for the 13-Week Studies

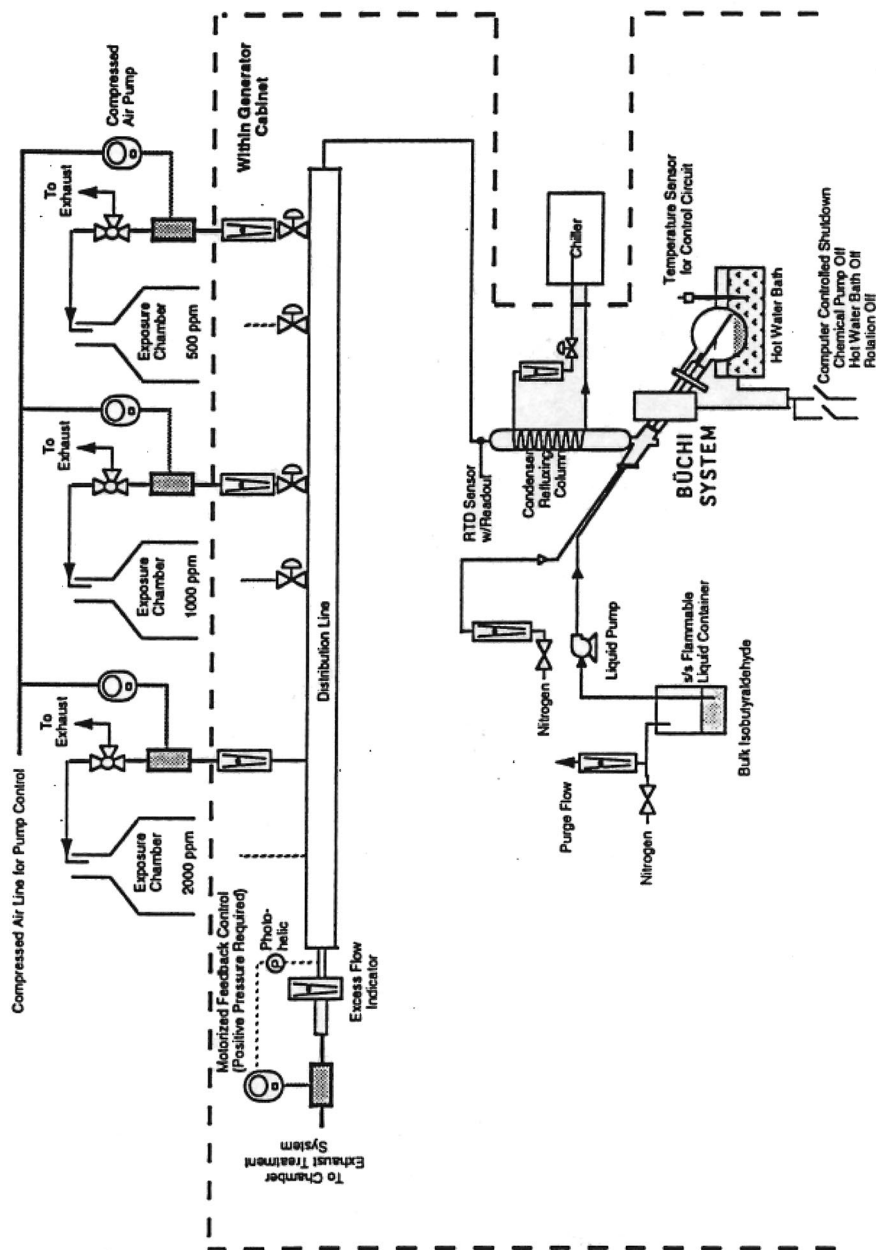

FIGURE I4
Schematic of Generation and Delivery System for the 2-Year Studies

TABLE I1
Summary of Chamber Concentrations in the 13-Week Inhalation Studies of Isobutyraldehyde

Target Concentration (ppm)	Total Number of Readings	Average Concentration ^a (ppm)
500	66	504 ± 19
1,000	66	994 ± 57
2,000	66	2,016 ± 94
4,000	66	4,034 ± 130
8,000	6 ^b	8,295 ± 416

^a Mean ± standard deviation

^b Because all rats and mice exposed to 8,000 ppm died during the first week of the studies, no readings were made after this week.

TABLE I2
Summary of Chamber Concentrations in the 2-Year Inhalation Studies of Isobutyraldehyde

Target Concentration (ppm)	Total Number of Readings	Average Concentration ^a (ppm)
Rat Chambers		
500	6,316	500 ± 11
1,000	6,388	1,010 ± 25
2,000	6,142	2,010 ± 47
Mouse Chambers		
500	6,315	501 ± 13
1,000	6,442	999 ± 28
2,000	6,194	2,000 ± 47

^a Mean ± standard deviation

APPENDIX J
INGREDIENTS, NUTRIENT COMPOSITION,
AND CONTAMINANT LEVELS
IN NIH-07 RAT AND MOUSE RATION

TABLE J1	Ingredients of NIH-07 Rat and Mouse Ration	232
TABLE J2	Vitamins and Minerals in NIH-07 Rat and Mouse Ration	232
TABLE J3	Nutrient Composition of NIH-07 Rat and Mouse Ration	233
TABLE J4	Contaminant Levels in NIH-07 Rat and Mouse Ration	234

TABLE J1
Ingredients of NIH-07 Rat and Mouse Ration^a

Ingredients ^b	Percent by Weight
Ground #2 yellow shelled corn	24.50
Ground hard winter wheat	23.00
Soybean meal (49% protein)	12.00
Fish meal (60% protein)	10.00
Wheat middlings	10.00
Dried skim milk	5.00
Alfalfa meal (dehydrated, 17% protein)	4.00
Corn gluten meal (60% protein)	3.00
Soy oil	2.50
Dried brewer's yeast	2.00
Dry molasses	1.50
Dicalcium phosphate	1.25
Ground limestone	0.50
Salt	0.50
Premixes (vitamin and mineral)	0.25

^a NCI, 1976; NIH, 1978

^b Ingredients were ground to pass through a U.S. Standard Screen No. 16 before being mixed.

TABLE J2
Vitamins and Minerals in NIH-07 Rat and Mouse Ration^a

	Amount	Source
Vitamins		
A	5,500,000 IU	Stabilized vitamin A palmitate or acetate
D ₃	4,600,000 IU	D-activated animal sterol
K ₃	2.8 g	Menadione
α-Tocopheryl acetate	20,000 IU	
Choline	560.0 g	Choline chloride
Folic acid	2.2 g	
Niacin	30.0 g	
<i>d</i> -Pantothenic acid	18.0 g	<i>d</i> -Calcium pantothenate
Riboflavin	3.4 g	
Thiamine	10.0 g	Thiamine mononitrate
B ₁₂	4,000 μg	
Pyridoxine	1.7 g	Pyridoxine hydrochloride
Biotin	140.0 mg	<i>d</i> -Biotin
Minerals		
Iron	120.0 g	Iron sulfate
Manganese	60.0 g	Manganous oxide
Zinc	16.0 g	Zinc oxide
Copper	4.0 g	Copper sulfate
Iodine	1.4 g	Calcium iodate
Cobalt	0.4 g	Cobalt carbonate

^a Per ton (2,000 lb) of finished product

TABLE J3
Nutrient Composition of NIH-07 Rat and Mouse Ration

Nutrient	Mean \pm Standard Deviation	Range	Number of Samples
Protein (% by weight)	23.42 \pm 0.57	22.2) 24.3	24
Crude fat (% by weight)	5.32 \pm 0.19	5.00) 5.90	24
Crude fiber (% by weight)	3.32 \pm 0.27	2.60) 3.70	24
Ash (% by weight)	6.42 \pm 0.19	6.12) 6.81	24
Amino Acids (% of total diet)			
Arginine	1.280 \pm 0.083	1.110) 1.390	11
Cystine	0.308 \pm 0.071	0.181) 0.400	11
Glycine	1.158 \pm 0.048	1.060) 1.220	11
Histidine	0.584 \pm 0.027	0.531) 0.630	11
Isoleucine	0.917 \pm 0.033	0.867) 0.965	11
Leucine	1.975 \pm 0.051	1.850) 2.040	11
Lysine	1.274 \pm 0.049	1.200) 1.370	11
Methionine	0.437 \pm 0.109	0.306) 0.699	11
Phenylalanine	0.999 \pm 0.120	0.665) 1.110	11
Threonine	0.904 \pm 0.058	0.824) 0.985	11
Tryptophan	0.218 \pm 0.153	0.107) 0.671	11
Tyrosine	0.685 \pm 0.094	0.564) 0.794	11
Valine	1.086 \pm 0.055	0.962) 1.170	11
Essential Fatty Acids (% of total diet)			
Linoleic	2.407 \pm 0.227	1.830) 2.570	10
Linolenic	0.259 \pm 0.065	0.100) 0.320	10
Vitamins			
Vitamin A (IU/kg)	6,762 \pm 1,340	5,730) 11,450	24
Vitamin D (IU/kg)	4,450 \pm 1,382	3,000) 6,300	4
α -Tocopherol (ppm)	35.43 \pm 8.98	22.5) 48.9	11
Thiamine (ppm)	17.62 \pm 2.02	14.0) 22.0	24
Riboflavin (ppm)	7.83 \pm 0.923	6.10) 9.00	11
Niacin (ppm)	99.22 \pm 24.27	65.0) 150.0	11
Pantothenic acid (ppm)	30.55 \pm 3.52	23.0) 34.6	11
Pyridoxine (ppm)	9.11 \pm 2.53	5.60) 14.0	11
Folic acid (ppm)	2.46 \pm 0.63	1.80) 3.70	11
Biotin (ppm)	0.268 \pm 0.047	0.190) 0.354	11
Vitamin B ₁₂ (ppb)	40.5 \pm 19.1	10.6) 65.0	11
Choline (ppm)	2,991 \pm 382	2,300) 3,430	10
Minerals			
Calcium (%)	1.17 \pm 0.10	1.00) 1.49	24
Phosphorus (%)	0.93 \pm 0.04	0.850) 1.00	24
Potassium (%)	0.886 \pm 0.063	0.772) 0.971	9
Chloride (%)	0.529 \pm 0.087	0.380) 0.635	9
Sodium (%)	0.316 \pm 0.033	0.258) 0.371	11
Magnesium (%)	0.166 \pm 0.010	0.148) 0.181	11
Sulfur (%)	0.272 \pm 0.059	0.208) 0.420	10
Iron (ppm)	350.5 \pm 87.3	255.0) 523.0	11
Manganese (ppm)	92.48 \pm 5.14	81.7) 99.4	11
Zinc (ppm)	59.33 \pm 10.2	46.1) 81.6	11
Copper (ppm)	11.81 \pm 2.50	8.09) 15.4	11
Iodine (ppm)	3.54 \pm 1.19	1.52) 5.83	10
Chromium (ppm)	1.66 \pm 0.46	0.85) 2.09	11
Cobalt (ppm)	0.76 \pm 0.23	0.49) 1.15	7

TABLE J4
Contaminant Levels in NIH-07 Rat and Mouse Ration^a

	Mean ± Standard Deviation ^b	Range	Number of Samples
Contaminants			
Arsenic (ppm)	0.42 ± 0.20	0.10) 0.70	24
Cadmium (ppm)	0.14 ± 0.07	0.05) 0.20	24
Lead (ppm)	0.35 ± 0.25	0.10) 1.00	24
Mercury (ppm) ^c	0.02	0.02) 0.03	24
Selenium (ppm)	0.32 ± 0.11	0.05) 0.40	24
Aflatoxins (ppm)	< 5.0		24
Nitrate nitrogen (ppm) ^d	9.15 ± 4.51	2.90) 17.0	24
Nitrite nitrogen (ppm) ^d	0.15 ± 0.08	0.10) 0.40	24
BHA (ppm) ^e	1.83 ± 1.97	1.00) 10.0	24
BHT (ppm) ^e	1.58 ± 1.61	1.0) 8.00	24
Aerobic plate count (CFU/g)	80,738 ± 146,881	4,100) 710,000	24
Coliform (MPN/g)	3 ± 0.2	3) 4	24
<i>Escherichia coli</i> (MPN/g)	< 3	24	
<i>Salmonella</i> (MPN/g)	Negative		24
Total nitrosoamines (ppb) ^f	7.47 ± 1.69	4.80) 11.40	24
N-Nitrosodimethylamine (ppb) ^f	5.50 ± 1.08	3.80) 8.20	24
N-Nitrosopyrrolidine (ppb) ^f	1.97 ± 1.08	1.00) 4.30	24
Pesticides (ppm)			
α-BHC	< 0.01		24
β-BHC	< 0.02		24
γ-BHC	< 0.01		24
δ-BHC	< 0.01		24
Heptachlor	< 0.01		24
Aldrin	< 0.01		24
Heptachlor epoxide	< 0.01		24
DDE	< 0.01		24
DDD	< 0.01		24
DDT	< 0.01		24
HCB	< 0.01		24
Mirex	< 0.01		24
Methoxychlor	< 0.05		24
Dieldrin	< 0.01		24
Endrin	< 0.01		24
Telodrin	< 0.01		24
Chlordane	< 0.05		24
Toxaphene	< 0.10		24
Estimated PCBs	< 0.20		24
Ronnel	< 0.01		24
Ethion	< 0.02		24
Trithion	< 0.05		24
Diazinon	< 0.10		24
Methyl parathion	< 0.02		24
Ethyl parathion	< 0.02		24
Malathion	0.24 ± 0.23	0.05) 0.97	24
Endosulfan I	< 0.01		24
Endosulfan II	< 0.01		24
Endosulfan sulfate	< 0.03		24

^a CFU = colony forming unit; MPN = most probable number; BHC = hexachlorocyclohexane or benzene hexachloride

^b For values less than the limit of detection, the detection limit is given as the mean.

^c All but three values were less than detection limit; detection limit was used for the low end of the range.

^d Sources of contamination: alfalfa, grains, and fish meal

^e Sources of contamination: soy oil and fish meal

^f All values were corrected for percent recovery.

APPENDIX K

SENTINEL ANIMAL PROGRAM

METHODS	236
RESULTS	238

SENTINEL ANIMAL PROGRAM

METHODS

Rodents used in the Carcinogenesis Program of the National Toxicology Program are produced in optimally clean facilities to eliminate potential pathogens that may affect study results. The Sentinel Animal Program is part of the periodic monitoring of animal health that occurs during the toxicologic evaluation of chemical compounds. Under this program, the disease state of the rodents is monitored via serology on sera from extra (sentinel) animals in the study rooms. These animals and the study animals are subject to identical environmental conditions. The sentinel animals come from the same production source and weanling groups as the animals used for the studies of chemical compounds.

Serum samples were collected from randomly selected rats and mice during the 13-week and 2-year studies. Blood from each animal was collected and allowed to clot, and the serum was separated. The samples were processed appropriately and sent to Microbiological Associates, Inc. (Bethesda, MD), for determination of antibody titers. The laboratory serology methods and viral agents for which testing was performed are tabulated below; the times at which blood was collected during the studies are also listed.

Method and Test

Time of Analysis

RATS

13-Week Study

ELISA

RCV/SDA (rat coronavirus/
sialodacryoadenitis virus)

Study termination

Hemagglutination Inhibition

H-1 (Toolan's H-1 virus)

Study termination

KRV (Kilham rat virus)

Study termination

PVM (pneumonia virus of mice)

Study termination

Sendai

Study termination

2-Year Study

ELISA

Mycoplasma arthritidis

Study termination

Mycoplasma pulmonis

Study termination

PVM

6, 12, and 18 months, study termination

RCV/SDA

6, 12, and 18 months, study termination

Sendai

6, 12, and 18 months, study termination

Immunofluorescence Assay

RCV/SDA

12 months and study termination

Hemagglutination Inhibition

H-1

6, 12, and 18 months, study termination

KRV

6, 12, and 18 months, study termination

Method and Test**Time of Analysis****MICE****13-Week Study**

Complement Fixation

LCM (lymphocytic choriomeningitis virus)

Study termination

Mouse adenoma virus

Study termination

ELISA

MHV (mouse hepatitis virus)

Study termination

Hemagglutination Inhibition

Ectromelia virus

Study termination

GDVII (mouse encephalomyelitis virus)

Study termination

MVM (minute virus of mice)

Study termination

PVM

Study termination

Polyoma virus

Study termination

Reovirus 3

Study termination

Sendai

Study termination

2-Year Study

ELISA

Ectromelia virus

6, 12, and 18 months, study termination

EDIM (epizootic diarrhea of infant mice)

6, 12, and 18 months, study termination

GDVII

6, 12, and 18 months, study termination

LCM

6, 12, and 18 months, study termination

Mouse adenoma virus

6, 12, and 18 months, study termination

MHV

6, 12, and 18 months, study termination

M. arthritidis

Study termination

M. pulmonis

Study termination

PVM

6, 12, and 18 months, study termination

Reovirus 3

6, 12, and 18 months, study termination

Sendai

6, 12, and 18 months, study termination

Immunofluorescence Assay

MHV

12 months

Reovirus 3

18 months

EDIM

18 months and study termination

Hemagglutination Inhibition

K (papovavirus)

6, 12, and 18 months, study termination

MVM

6, 12, and 18 months, study termination

Polyoma virus

6, 12, and 18 months, study termination

RESULTS

Four rats had positive titers for *M. arthritidis* at the end of the 2-year study. Further evaluation of samples positive for *M. arthritidis* by immunoblot and Western blot procedures indicated that the positive titers may have been due to cross reaction with antibodies of nonpathogenic *Mycoplasma* or other agents. Only sporadic samples were positive and there were no clinical findings or histopathologic changes of *M. arthritidis* infection in animals with positive titers. Accordingly, *M. arthritidis*-positive titers were considered false positives.