



NTP

National Toxicology Program

U.S. Department of Health and Human Services

NTP TECHNICAL REPORT ON
THE TOXICOLOGY AND
CARCINOGENESIS STUDIES OF

VANADIUM PENTOXIDE
(CAS No. 1314-62-1)
IN F344/N RATS AND
B6C3F₁ MICE
(INHALATION STUDIES)

NTP TR 507

DECEMBER 2002

NTP TECHNICAL REPORT
ON THE
TOXICOLOGY AND CARCINOGENESIS
STUDIES OF VANADIUM PENTOXIDE
(CAS NO. 1314-62-1)
IN F344/N RATS AND B6C3F₁ MICE
(INHALATION STUDIES)

NATIONAL TOXICOLOGY PROGRAM
P.O. Box 12233
Research Triangle Park, NC 27709

December 2002

NTP TR 507

NIH Publication No. 03-4441

U.S. DEPARTMENT OF HEALTH AND HUMAN SERVICES
Public Health Service
National Institutes of Health

ADDENDUM

Additional information has been added to *NTP Technical Report on the Toxicology and Carcinogenesis Studies of Vanadium Pentoxide (CAS No. 1314-62-1) in F344/N Rats and B6C3F1 Mice (Inhalation Studies)* (TR 507). [May 9, 2022]

Addendum to Discussion

It is noteworthy that vanadium was detected in the blood of female rats (Table K6, 0.21 ± 0.01 to 0.30 ± 0.05 mg V/g) and mice (Table K11, 0.26 ± 0.01 to 0.5 ± 0.1 mg V/g) from the chamber control groups. Similar vanadium concentrations were observed in blood obtained from commercial sources for validation of the inductively coupled plasma/atomic emission spectroscopy (ICP/AES) method to measure vanadium concentrations (rat, 0.273 ± 0.014 mg V/g; mouse, 0.377 ± 0.038 mg V/g). Nonetheless, the blood concentrations observed in rats and mice in the chamber control groups were lower than those observed in vanadium pentoxide-exposed groups for a given day. For example, in the 2-year study on postexposure day 54, the blood vanadium concentrations in vanadium pentoxide-exposed female rats ranged from 0.33 ± 0.02 to 0.37 ± 0.05 mg V/g, whereas the corresponding chamber control value was 0.23 ± 0.11 mg V/g (Table K6). Similarly, the blood vanadium concentrations in vanadium pentoxide-exposed female mice on day 54 ranged from 0.58 ± 0.05 to 0.91 ± 0.08 mg V/g, whereas the corresponding chamber control value was 0.5 ± 0.1 mg V/g (Table K11). Additionally, despite the observed vanadium concentrations in the chamber control groups, there was an exposure-concentration dependent increase in blood vanadium concentrations in both female rats and mice exposed to vanadium pentoxide (Tables K6 and K11). Importantly, as reported in Dill *et al.* (2014), the blood vanadium concentrations in the vanadium pentoxide-exposed groups were corrected by subtracting the values in the corresponding chamber control group at each time point prior to their use in the kinetic model (Dill *et al.*, 2004).

Vanadium pentoxide aerosol concentrations in the exposure room and the control and exposure chambers were determined routinely during the study using real-time aerosol monitors (RAMs). For example, as stated in the methods, over the course of the studies, the concentrations of aerosol were measured in the exposure room and control chambers $>6,000$ times (Table L4 Addendum) and in the exposure chambers for each vanadium pentoxide exposure group (0.5, 1, and 2 mg/m³ or 1, 2, and 4 mg/m³ for rats or mice, respectively) $>4,800$ times (Table L4). The mean of these measurements was less than the limit of detection for vanadium pentoxide (≤ 0.026 mg/m³) for the exposure room and control chambers, whereas for the exposed groups of rats and mice, chamber concentrations averaged 100%–101% of target with relative standard deviations within 10%. At least weekly, vanadium-specific ICP/AES or ICP/mass spectrometry methods were used to determine chamber vanadium concentrations and served as a means for verifying the calibration or recalibration of each RAM.

The findings from the 2-year study of vanadium pentoxide showed that the major target was the respiratory tract, predominantly the lung, with little to no evidence of systemic toxicity. In addition, the lung vanadium concentrations were much higher than those in the blood. For example, in female rats, lung concentrations reached a maximum of 11.8 µg vanadium/g on day 173 in the lowest exposure group (0.5 mg/m³). At the same time point for these animals, the vanadium concentration in blood was 50-fold lower (0.24 µg vanadium/g). Similarly, in the lowest exposure group of female mice (1 mg/m³), the blood vanadium concentration (0.40 µg vanadium/g) was 32.5-fold lower than the lung vanadium lung concentration on day 171 (13.0 µg vanadium/g).

Taken collectively, these data support that: 1) the vanadium levels observed in blood from control animals are not due to unintentional exposure to vanadium pentoxide or other vanadium-containing compounds via inhalation or other routes of exposure and 2) the only exposure to vanadium in the exposed groups was from the test material, vanadium pentoxide, via inhalation at the specified concentrations of 0.5, 1, and 2 mg/m³ in rats and 1, 2, and 4 mg/m³ in mice.

Table L4 Addendum
Summary of Chamber Concentrations in the 2-Year Inhalation Studies of Vanadium Pentoxide

	Target Concentration (mg/m ³)	Total Number of Readings	Average Concentration ^a (mg/m ³)
Rat Chambers			
	Exposure room	6,080	<LOD ^b
	0	6,080	<LOD ^c
Mouse Chambers			
	Exposure room	6,032	<LOD ^b
	0	6,028	<LOD ^d

LOD = limit of detection.

^a Mean ± standard deviation

^b 0.005 mg/m³

^c 0.023 mg/m³

^d 0.026 mg/m³

FOREWORD

The National Toxicology Program (NTP) is made up of four charter agencies of the U.S. Department of Health and Human Services (DHHS): the National Cancer Institute (NCI), National Institutes of Health; the National Institute of Environmental Health Sciences (NIEHS), National Institutes of Health; the National Center for Toxicological Research (NCTR), Food and Drug Administration; and the National Institute for Occupational Safety and Health (NIOSH), Centers for Disease Control and Prevention. In July 1981, the Carcinogenesis Bioassay Testing Program, NCI, was transferred to the NIEHS. The NTP coordinates the relevant programs, staff, and resources from these Public Health Service agencies relating to basic and applied research and to biological assay development and validation.

The NTP develops, evaluates, and disseminates scientific information about potentially toxic and hazardous chemicals. This knowledge is used for protecting the health of the American people and for the primary prevention of disease.

The studies described in this Technical Report were performed under the direction of the NIEHS and were conducted in compliance with NTP laboratory health and safety requirements and must meet or exceed all applicable federal, state, and local health and safety regulations. Animal care and use were in accordance with the Public Health Service Policy on Humane Care and Use of Animals. The prechronic and chronic studies were conducted in compliance with Food and Drug Administration (FDA) Good Laboratory Practice Regulations, and all aspects of the chronic studies were subjected to retrospective quality assurance audits before being presented for public review.

These studies are designed and conducted to characterize and evaluate the toxicologic potential, including carcinogenic activity, of selected chemicals in laboratory animals (usually two species, rats and mice). Chemicals selected for NTP toxicology and carcinogenesis studies are chosen primarily on the bases of human exposure, level of production, and chemical structure. The interpretive conclusions presented in this Technical Report are based only on the results of these NTP studies. Extrapolation of these results to other species and quantitative risk analyses for humans require wider analyses beyond the purview of these studies. Selection *per se* is not an indicator of a chemical's carcinogenic potential.

Details about ongoing and completed NTP studies are available at the NTP's World Wide Web site: <http://ntp-server.niehs.nih.gov>. Abstracts of all NTP Technical Reports and full versions of the most recent reports and other publications are available from the NIEHS' Environmental Health Perspectives (EHP) <http://ehp.niehs.nih.gov> (800-315-3010 or 919-541-3841). In addition, printed copies of these reports are available from EHP as supplies last. A listing of all the NTP Technical Reports printed since 1982 appears on the inside back cover.

NTP TECHNICAL REPORT
ON THE
TOXICOLOGY AND CARCINOGENESIS
STUDIES OF VANADIUM PENTOXIDE

(CAS NO. 1314-62-1)

IN F344/N RATS AND B6C3F₁ MICE

(INHALATION STUDIES)

NATIONAL TOXICOLOGY PROGRAM
P.O. Box 12233
Research Triangle Park, NC 27709

December 2002

NTP TR 507

NIH Publication No. 03-4441

U.S. DEPARTMENT OF HEALTH AND HUMAN SERVICES
Public Health Service
National Institutes of Health

CONTRIBUTORS

National Toxicology Program

Evaluated and interpreted results and reported findings

N.B. Ress, Ph.D., Study Scientist
 J.H. Roycroft, Ph.D., Study Scientist
 D.W. Bristol, Ph.D.
 J.R. Bucher, Ph.D.
 J.R. Hailey, D.V.M.
 J.K. Haseman, Ph.D.
 R.A. Herbert, D.V.M., Ph.D.
 R.R. Maronpot, D.V.M.
 D.P. Orzech, M.S.
 S.D. Peddada, Ph.D.
 G.N. Rao, D.V.M., Ph.D.
 C.S. Smith, Ph.D.
 G.S. Travlos, D.V.M.
 K.L. Witt, M.S., ILS, Inc.

IITRI

*Conducted 16-day and 3-month studies
 and evaluated pathology findings*

C. Aranyi, M.S., Principal Investigator
 D.T. Kirkpatrick, Ph.D.
 R.E. Long, D.V.M.
 N. Rajendran, Ph.D.
 A. Snelson, Ph.D.
 M.J. Tomlinson, D.V.M., Ph.D.
 S.C. Vana, B.S.

Battelle Toxicology Northwest

*Conducted 16-day special studies and 2-year studies
 and evaluated pathology findings*

B.J. Chou, D.V.M., Ph.D., Principal Investigator
 J.A. Dill, Ph.D., Principal Investigator
 M.L. Clark, M.S.E.
 S.R. Baum, B.S.
 K.M. Lee, Ph.D.
 R.A. Miller, D.V.M., Ph.D.
 E.W. Morgan, M.S.E.
 R.A. Renne, D.V.M.

Experimental Pathology Laboratories, Inc.

Provided pathology quality assurance

J.F. Hardisty, D.V.M., Principal Investigator
 A.E. Brix, D.V.M., Ph.D.
 J.C. Seely, D.V.M.

NTP Pathology Working Group

*Evaluated slides and prepared pathology report on rats
 (July 27, 2000)*

M.T. Butt, D.V.M., Chairperson
 Pathology Associates International
 A.E. Brix, D.V.M., Ph.D.
 Experimental Pathology Laboratories, Inc.
 D. Dungworth, D.V.M.
 University of California, Davis
 J. Everitt, D.V.M.
 Chemical Industry Institute of Toxicology
 G.P. Flake, M.D.
 National Toxicology Program
 J.R. Hailey, D.V.M.
 National Toxicology Program
 R.A. Herbert, D.V.M., Ph.D.
 National Toxicology Program
 M.P. Jokinen, D.V.M.
 Pathology Associates International
 R.R. Maronpot, D.V.M.
 National Toxicology Program
 K. Nikula, D.V.M., Ph.D.
 Monsanto
 A. Nyska, D.V.M.
 National Toxicology Program
 R.A. Renne, D.V.M.
 Battelle Toxicology Northwest

*Evaluated slides and prepared pathology report on mice
 (August 21, 2000)*

M.P. Jokinen, D.V.M., Chairperson
 Pathology Associates International
 D. Dixon, D.V.M., Ph.D.
 National Toxicology Program
 J. Everitt, D.V.M.
 Chemical Industry Institute of Toxicology
 G.P. Flake, M.D.
 National Toxicology Program
 J.R. Hailey, D.V.M.
 National Toxicology Program
 R.A. Herbert, D.V.M., Ph.D.
 National Toxicology Program
 M. Jayo, D.V.M., Ph.D., Observer
 Pathology Associates International
 R.A. Miller, D.V.M., Ph.D.
 Battelle Toxicology Northwest
 A. Nyska, D.V.M.
 National Toxicology Program
 K. Ozaki, D.V.M., Ph.D., Observer
 National Toxicology Program
 J.C. Seely, D.V.M.
 Experimental Pathology Laboratories, Inc.

Dynamac Corporation

Prepared quality assurance audits

S. Brecher, Ph.D., Principal Investigator

Analytical Sciences, Inc.

Provided statistical analyses

P.W. Crockett, Ph.D., Principal Investigator

L.J. Betz, M.S.

M.R. Easterling, Ph.D.

K.P. McGowan, M.B.A.

J.T. Scott, M.S.

Biotechnical Services, Inc.

Prepared Technical Report

S.R. Gunnels, M.A., Principal Investigator

L.M. Harper, B.S.

D.C. Serbus, Ph.D.

B.F. Hall, M.S.

R.A. Willis, B.A., B.S.

P.A. Yount, B.S.

CONTENTS

ABSTRACT	7
EXPLANATION OF LEVELS OF EVIDENCE OF CARCINOGENIC ACTIVITY	12
TECHNICAL REPORTS REVIEW SUBCOMMITTEE	13
SUMMARY OF TECHNICAL REPORTS REVIEW SUBCOMMITTEE COMMENTS	14
INTRODUCTION	17
MATERIALS AND METHODS	27
RESULTS	45
DISCUSSION AND CONCLUSIONS	93
REFERENCES	99
APPENDIX A Summary of Lesions in Male Rats in the 2-Year Inhalation Study of Vanadium Pentoxide	109
APPENDIX B Summary of Lesions in Female Rats in the 2-Year Inhalation Study of Vanadium Pentoxide	149
APPENDIX C Summary of Lesions in Male Mice in the 2-Year Inhalation Study of Vanadium Pentoxide	185
APPENDIX D Summary of Lesions in Female Mice in the 2-Year Inhalation Study of Vanadium Pentoxide	225
APPENDIX E Genetic Toxicology	263
APPENDIX F Cardiopulmonary Physiology Studies	269
APPENDIX G Clinical Pathology Results	275
APPENDIX H Organ Weights and Organ-Weight-to-Body-Weight Ratios	283
APPENDIX I Reproductive Tissue Evaluations and Estrous Cycle Characterization	289
APPENDIX J Immunotoxicology Studies	293
APPENDIX K Tissue Burden Results	299
APPENDIX L Chemical Characterization and Generation of Chamber Concentrations	313

APPENDIX M	Ingredients, Nutrient Composition, and Contaminant Levels in NTP-2000 Rat and Mouse Ration	329
APPENDIX N	Sentinel Animal Program	333
APPENDIX O	Molecular Oncology Studies	337

SUMMARY

Background

Vanadium pentoxide is used in the production of vanadium and steel alloys and is emitted by burning fossil fuels. Exposure to vanadium pentoxide occurs during the cleaning of oil-fired boilers and furnaces.

Methods

We exposed groups of 50 male and 50 female rats to atmospheres containing aerosols of 0.5, 1, or 2 mg of vanadium pentoxide particles per cubic meter of air. We also exposed groups of 50 male and 50 female mice to atmospheres containing 1, 2, or 4 mg vanadium pentoxide per cubic meter. Animals were exposed six hours per day, five days per week for two years. Tissues from more than 40 sites on each animal were examined.

Results

Male rats exposed to vanadium pentoxide had greater than normal incidences of lung neoplasms, and some lung tumors also occurred in exposed female rats. Other lesions including inflammation, fibrosis, and hyperplasia also occurred in the respiratory tract (nose, larynx, and lung) of male and female rats. These lesions were more severe at higher vanadium pentoxide concentrations. Male and female mice had even greater incidences of alveolar/bronchiolar neoplasms of the lung, and many of the male mice in the highest exposure group died before the end of the study. Lesions including epithelial hyperplasia, inflammation, fibrosis, and squamous metaplasia occurred in the respiratory tract (nose, larynx, and lung) of male and female mice.

Conclusions

We conclude that exposure to vanadium pentoxide particles caused lung neoplasms in male rats and possibly in female rats, and in male and female mice. A spectrum of other nonneoplastic lesions in the respiratory tract of male and female rats and mice were caused by vanadium pentoxide exposure.

ABSTRACT



VANADIUM PENTOXIDE

CAS No. 1314-62-1

Chemical Formula: V_2O_5 Molecular Weight: 181.88

Synonyms: Divanadium pentoxide; vanadic anhydride; vanadium (5) oxide; vanadium oxide; vanadium pentaoxide

Vanadium pentoxide, commercially the most important compound of vanadium, presents a potential occupational hazard during the cleaning of oil-fired boilers and furnaces, the handling of catalysts, and during the refining, processing, or burning of vanadium-rich mineral ores or fossil fuels. Vanadium pentoxide was nominated for study by the National Cancer Institute as a representative of the metals class study. Male and female F344/N rats and B6C3F₁ mice were exposed to vanadium pentoxide (99% pure) by inhalation for 16 days, 14 weeks, or 2 years. Genetic toxicology studies were conducted in *Salmonella typhimurium* and mouse peripheral blood.

16-DAY STUDY IN RATS

Groups of five male and five female rats were exposed to particulate aerosols of vanadium pentoxide at concentrations of 0, 2, 4, 8, 16, or 32 mg/m³ by inhalation, 6 hours per day, 5 days per week for 16 days. Three males in the 32 mg/m³ group died before the end of the study. Mean body weights of males and females exposed to 8 mg/m³ or greater were less than those of the chamber controls. Clinical findings included rapid respiration and hypoactivity in rats exposed to 16 or 32 mg/m³. Relative lung weights of 4 mg/m³ or greater males and 2 mg/m³ or greater females were significantly greater than those of the chamber controls. Lavage fluid

analysis indicated an inflammatory response in the lung that was either directly mediated by vanadium pentoxide or was secondary to lung damage induced by vanadium pentoxide exposure.

16-DAY STUDY IN MICE

Groups of five male and five female mice were exposed to particulate aerosols of vanadium pentoxide at concentrations of 0, 2, 4, 8, 16, or 32 mg/m³ by inhalation, 6 hours per day, 5 days per week for 16 days. All males exposed to 32 mg/m³ and one 8 mg/m³ male died or were killed moribund before the end of the study. Mean body weights of 16 mg/m³ males and 8 mg/m³ or greater females were significantly less than those of the chamber controls, and the 32 mg/m³ females lost weight during the study. Absolute and relative lung weights of 4 mg/m³ or greater males and all exposed groups of females and liver weights of 16 mg/m³ males were significantly greater than those of the chamber controls. The mediastinal lymph nodes were enlarged in 4, 8, and 16 mg/m³ males and females, and lymphoid hyperplasia was confirmed histologically. Lavage fluid analysis indicated an inflammatory response in the lung that was either directly mediated by vanadium pentoxide or was secondary to lung damage induced by vanadium pentoxide exposure.

3-MONTH STUDY IN RATS

Groups of 10 male and 10 female rats were exposed to particulate aerosols of vanadium pentoxide at concentrations of 0, 1, 2, 4, 8, or 16 mg/m³ by inhalation, 6 hours per day, 5 days per week for 3 months. Seven males and three females exposed to 16 mg/m³ died during the study. Mean body weights were significantly less in males exposed to 4 mg/m³ or greater and in females exposed to 16 mg/m³. Abnormal breathing, thinness, lethargy, abnormal posture, and ruffled fur were observed in rats exposed to 16 mg/m³.

Hematology results indicated that exposure of rats to vanadium pentoxide induced a microcytic erythrocytosis in males and females. Absolute and relative lung weights were significantly greater for 4 mg/m³ or greater males and females than for the chamber controls as were the relative lung weights of 2 mg/m³ males. The estrous cycle of females exposed to 8 mg/m³ was significantly longer than that of the chamber control group, and the number of cycling females in the 16 mg/m³ group was reduced. The incidences of several nonneoplastic lesions of the lung and nose were significantly increased in males and females exposed to 2 mg/m³ or greater. Data from pulmonary function analyses indicated that a restrictive lung disease was present in male and female rats exposed to 4 mg/m³ or greater, while an obstructive lung disease was present only in the 16 mg/m³ groups.

3-MONTH STUDY IN MICE

Groups of 10 male and 10 female mice were exposed to particulate aerosols of vanadium pentoxide at concentrations of 0, 1, 2, 4, 8, or 16 mg/m³ by inhalation, 6 hours per day, 5 days per week for 3 months. One male exposed to 16 mg/m³ died before the end of the study. Mean body weights of 8 and 16 mg/m³ males and 4 mg/m³ or greater females were significantly less than those of the chamber controls. Absolute and relative lung weights of males and females exposed to 4 mg/m³ or greater were significantly greater than those of the chamber controls. The epididymal spermatozoal motility of males exposed to 8 or 16 mg/m³ was significantly decreased. Some mice exposed to 2 or 4 mg/m³ had inflammation of the lung, and all mice exposed to 8 or 16 mg/m³ had inflammation and epithelial hyperplasia of the lung.

16-DAY SPECIAL STUDY IN RATS

Groups of 60 female rats were exposed to particulate aerosols of vanadium pentoxide at concentrations of 0, 1, or 2 mg/m³ and groups of 40 female rats were exposed to 4 mg/m³ by inhalation, 6 hours per day, 5 days per week for 16 days. Alveolar and bronchiolar epithelial hyperplasia was observed in most rats exposed to 2 or 4 mg/m³ on days 6 and 13. Histiocytic infiltration and inflammation occurred in a time- and concentration-related manner. Cell turnover rates were increased in the terminal bronchioles on days 6 and 13 and in the alveoli in the 4 mg/m³ group on day 6 and in all exposed groups on day 13. Assessment of lung vanadium concentrations suggested deposition and clearance exhibited linear kinetics over the exposure range studied. Lung clearance half-times ranged from 4.42 to 4.96 days.

16-DAY SPECIAL STUDY IN MICE

Groups of 60 female mice were exposed to particulate aerosols of vanadium pentoxide at concentrations of 0, 2, or 4 mg/m³ and groups of 40 female mice were exposed to 8 mg/m³ by inhalation, 6 hours per day, 5 days per week for 16 days. Alveolar and bronchiolar epithelial hyperplasia occurred with similar incidences and severities among the exposed groups on days 6 and 13, and time- and concentration-related increases in the incidences of interstitial inflammation and histiocytic infiltration also occurred in these groups. Cell turnover rates were increased in the terminal bronchioles on day 6 and remained greater than those of the chamber controls on day 13. In the alveoli, cell turnover rates were increased in an exposure concentration-related manner on day 13; cell turnover rates were increased only in the 8 mg/m³ group on day 6. Assessment of lung vanadium concentrations suggested deposition and clearance exhibited linear kinetics over the exposure range studied. Lung clearance half-times ranged from 2.40 to 2.55 days.

2-YEAR STUDY IN RATS

Groups of 50 male and 50 female rats were exposed to particulate aerosols of vanadium pentoxide at concentrations of 0, 0.5, 1, or 2 mg/m³ by inhalation, 6 hours per day, 5 days per week for 104 weeks. Survival and body weights of males and females were generally similar to

those of the chamber controls. Mean body weights of females exposed to 2 mg/m³ were less than those of the chamber controls throughout the study.

Alveolar/bronchiolar neoplasms were present in exposed groups of male rats, and the incidences often exceeded the historical control ranges. Alveolar/bronchiolar adenomas were present in 0.5 and 1 mg/m³ females; one 2 mg/m³ female also had an alveolar/bronchiolar carcinoma. The incidence of alveolar/bronchiolar adenoma in the 0.5 mg/m³ group was at the upper end of the historical control ranges. Nonneoplastic lesions related to vanadium pentoxide exposure occurred in the respiratory system (lung, larynx, and nose) of male and female rats, and the severities of these lesions generally increased with increasing exposure concentration.

2-YEAR STUDY IN MICE

Groups of 50 male and 50 female mice were exposed to particulate aerosols of vanadium pentoxide at concentrations of 0, 1, 2, or 4 mg/m³ by inhalation, 6 hours per day, 5 days per week for 104 weeks. Survival of 4 mg/m³ males was significantly less than that of the chamber controls. Mean body weights of 4 mg/m³ males and all exposed groups of females were generally less than those of the chamber controls throughout the study, and those of males exposed to 2 mg/m³ were less from week 85 to the end of the study. Many mice exposed to vanadium pentoxide were thin, and abnormal breathing was observed in some mice, particularly those exposed to 2 or 4 mg/m³.

The incidences of alveolar/bronchiolar neoplasms were significantly increased in all groups of exposed males and females. Nonneoplastic lesions related to vanadium pentoxide exposure occurred in the respiratory system (lung, larynx, and nose) of male and female mice, and the severities of these lesions generally increased with

increasing exposure concentration. Bronchial lymph node hyperplasia was present in many exposed females.

MOLECULAR ONCOLOGY STUDIES

K-*ras* codon 12 mutation and loss of heterozygosity on chromosome 6 were detected in vanadium pentoxide-induced alveolar/bronchiolar carcinomas from mice.

GENETIC TOXICOLOGY

Vanadium pentoxide was not mutagenic in *Salmonella typhimurium* strain TA97, TA98, TA100, TA102, or TA1535, with or without induced rat or hamster liver S9 enzymes. Vanadium pentoxide, administered for 3 months by inhalation to male and female mice, did not increase the frequency of micronucleated normochromatic erythrocytes in peripheral blood.

CONCLUSIONS

Under the conditions of this 2-year inhalation study, there was *some evidence of carcinogenic activity** of vanadium pentoxide in male F344/N rats and *equivocal evidence of carcinogenic activity* of vanadium pentoxide in female F344/N rats based on the occurrence of alveolar/bronchiolar neoplasms. There was *clear evidence of carcinogenic activity* of vanadium pentoxide in male and female B6C3F₁ mice based on increased incidences of alveolar/bronchiolar neoplasms.

Exposure to vanadium pentoxide caused a spectrum of nonneoplastic lesions in the respiratory tract (nose, larynx, and lung) including alveolar and bronchiolar epithelial hyperplasia, inflammation, fibrosis, and alveolar histiocytosis of the lung in male and female rats and mice and an unusual squamous metaplasia of the lung in male and female rats. Hyperplasia of the bronchial lymph node occurred in female mice.

* Explanation of Levels of Evidence of Carcinogenic Activity is on page 12. A Summary of the Technical Reports Review Subcommittee comments and the public discussion on the Technical Report appears on page 14.

Summary of the 2-Year Carcinogenesis and Genetic Toxicology Studies of Vanadium Pentoxide

	Male F344/N Rats	Female F344/N Rats	Male B6C3F ₁ Mice	Female B6C3F ₁ Mice
Concentrations in air	Chamber control, 0.5, 1, or 2 mg/m ³	Chamber control, 0.5, 1, or 2 mg/m ³	Chamber control, 1, 2, or 4 mg/m ³	Chamber control, 1, 2, or 4 mg/m ³
Body weights	Exposed groups similar to the chamber control group	2 mg/m ³ group less than the chamber control group	2 and 4 mg/m ³ groups less than the chamber control group	Exposed groups less than the chamber control group
Survival rates	20/50, 29/50, 26/50, 27/50	33/50, 24/50, 29/50, 30/50	39/50, 33/50, 36/50, 27/50	38/50, 32/50, 30/50, 32/50
Nonneoplastic effects	<p><u>Lung</u>: alveolar epithelium, hyperplasia (7/50, 24/49, 34/48, 49/50); bronchiole, epithelium hyperplasia (3/50, 17/49, 31/48, 49/50); alveolar epithelium, metaplasia, squamous (1/50, 0/49, 0/48, 21/50); bronchiole, metaplasia, squamous (0/50, 0/49, 0/48, 7/50); inflammation, chronic active (5/50, 8/49, 24/48, 42/50); interstitial, fibrosis (7/50, 7/49, 16/48, 38/50); alveolus, infiltration cellular, histiocyte (22/50, 40/49, 45/48, 50/50)</p> <p><u>Larynx</u>: inflammation, chronic (3/49, 20/50, 17/50, 28/49); respiratory epithelium, epiglottis degeneration (0/49, 22/50, 23/50, 33/49); respiratory epithelium, epiglottis, hyperplasia (0/49, 18/50, 34/50, 32/49); respiratory epithelium, epiglottis, metaplasia, squamous (0/49, 9/50, 16/50, 19/49)</p> <p><u>Nose</u>: goblet cell, respiratory epithelium, hyperplasia (4/49, 15/50, 12/49, 17/48)</p>	<p><u>Lung</u>: alveolar epithelium, hyperplasia (4/49, 8/49, 21/50, 50/50); bronchiole, epithelium hyperplasia (6/49, 5/49, 14/50, 48/50); alveolar epithelium, metaplasia, squamous (0/49, 0/49, 0/50, 6/50); inflammation, chronic active (10/49, 10/49, 14/50, 40/50); interstitial, fibrosis (19/49, 7/49, 12/50, 32/50); alveolus, infiltration cellular, histiocyte (26/49, 35/49, 44/50, 50/50)</p> <p><u>Larynx</u>: inflammation, chronic (8/50, 26/49, 27/49, 37/50); respiratory epithelium, epiglottis degeneration (2/50, 33/49, 26/49, 40/50); respiratory epithelium, epiglottis, hyperplasia (0/50, 25/49, 26/49, 33/50); respiratory epithelium, epiglottis, metaplasia, squamous (2/50, 7/49, 7/49, 16/50)</p> <p><u>Nose</u>: goblet cell, respiratory epithelium, hyperplasia (13/50, 18/50, 16/50, 30/50)</p>	<p><u>Lung</u>: alveolar epithelium, hyperplasia (3/50, 41/50, 49/50, 50/50); bronchiole, epithelium, hyperplasia (0/50, 15/50, 37/50, 46/50); inflammation chronic (6/50, 42/50, 45/50, 47/50); alveolus, infiltration cellular, histiocyte (10/50, 36/50, 45/50, 49/50); interstitial fibrosis (1/50, 6/50, 9/50, 12/50)</p> <p><u>Larynx</u>: respiratory epithelium, epiglottis, metaplasia, squamous (2/49, 45/50, 41/48, 41/50)</p> <p><u>Nose</u>: inflammation suppurative (16/50, 11/50, 32/50, 23/50); olfactory epithelium, degeneration, hyaline (1/50, 7/50, 23/50, 30/50); respiratory epithelium, degeneration, hyaline (8/50, 22/50, 38/50, 41/50); respiratory epithelium, metaplasia, squamous (0/50, 6/50, 6/50, 2/50)</p>	<p><u>Lung</u>: alveolar epithelium, hyperplasia (0/50, 31/50, 38/50, 50/50); bronchiole, epithelium, hyperplasia (0/50, 12/50, 34/50, 48/50); inflammation chronic (4/50, 37/50, 39/50, 49/50); alveolus, infiltration cellular, histiocyte (0/50, 34/50, 35/50, 45/50); interstitial fibrosis (0/50, 1/50, 4/50, 8/50)</p> <p><u>Larynx</u>: respiratory epithelium, epiglottis, metaplasia, squamous (0/50, 39/50, 45/49, 44/50)</p> <p><u>Nose</u>: inflammation suppurative (19/50, 14/50, 32/50, 30/50); olfactory epithelium, atrophy (2/50, 8/50, 5/50, 14/50); olfactory epithelium, degeneration, hyaline (11/50, 23/50, 34/50, 48/50); respiratory epithelium, degeneration, hyaline (35/50, 39/50, 46/50, 50/50); respiratory epithelium, metaplasia, squamous (0/50, 3/50, 7/50, 8/50); respiratory epithelium, necrosis (0/50, 0/50, 1/50, 7/50)</p> <p><u>Bronchial lymph node</u>: hyperplasia (3/39, 13/40, 14/45, 20/41)</p>

Summary of the 2-Year Carcinogenesis and Genetic Toxicology Studies of Vanadium Pentoxide

	Male F344/N Rats	Female F344/N Rats	Male B6C3F ₁ Mice	Female B6C3F ₁ Mice
Neoplastic effects	<u>Lung</u> : alveolar/ bronchiolar adenoma (4/50, 8/49, 5/48, 6/50); alveolar/bronchiolar carcinoma (0/50, 3/49, 1/48, 3/50); alveolar/ bronchiolar adenoma or carcinoma (4/50, 10/49, 6/48, 9/50)	None	<u>Lung</u> : alveolar/ bronchiolar adenoma (13/50, 16/50, 26/50, 15/50); alveolar/ bronchiolar carcinoma (12/50, 29/50, 30/50, 35/50); alveolar/ bronchiolar adenoma or carcinoma (22/50, 42/50, 43/50, 43/50)	<u>Lung</u> : alveolar/ bronchiolar adenoma (1/50, 17/50, 23/50, 19/50); alveolar/ bronchiolar carcinoma (0/50, 23/50, 18/50, 22/50); alveolar/ bronchiolar adenoma or carcinoma (1/50, 32/50, 35/50, 32/50)
Equivocal findings	None	<u>Lung</u> : alveolar/ bronchiolar adenoma (0/49, 3/49, 1/50, 0/50); alveolar/bronchiolar adenoma or carcinoma (0/49, 3/49, 1/50, 1/50)	None	None
Level of evidence of carcinogenic activity	Some evidence	Equivocal evidence	Clear evidence	Clear evidence
Genetic toxicology				
<i>Salmonella typhimurium</i> gene mutations:		Negative in strains TA97, TA98, TA100, TA102 and TA1535 with and without S9		
Micronucleated erythrocytes				
Mouse peripheral blood <i>in vivo</i> :		Negative		

EXPLANATION OF LEVELS OF EVIDENCE OF CARCINOGENIC ACTIVITY

The National Toxicology Program describes the results of individual experiments on a chemical agent and notes the strength of the evidence for conclusions regarding each study. Negative results, in which the study animals do not have a greater incidence of neoplasia than control animals, do not necessarily mean that a chemical is not a carcinogen, inasmuch as the experiments are conducted under a limited set of conditions. Positive results demonstrate that a chemical is carcinogenic for laboratory animals under the conditions of the study and indicate that exposure to the chemical has the potential for hazard to humans. Other organizations, such as the International Agency for Research on Cancer, assign a strength of evidence for conclusions based on an examination of all available evidence, including animal studies such as those conducted by the NTP, epidemiologic studies, and estimates of exposure. Thus, the actual determination of risk to humans from chemicals found to be carcinogenic in laboratory animals requires a wider analysis that extends beyond the purview of these studies.

Five categories of evidence of carcinogenic activity are used in the Technical Report series to summarize the strength of the evidence observed in each experiment: two categories for positive results (**clear evidence and some evidence**); one category for uncertain findings (**equivocal evidence**); one category for no observable effects (**no evidence**); and one category for experiments that cannot be evaluated because of major flaws (**inadequate study**). These categories of interpretative conclusions were first adopted in June 1983 and then revised in March 1986 for use in the Technical Report series to incorporate more specifically the concept of actual weight of evidence of carcinogenic activity. For each separate experiment (male rats, female rats, male mice, female mice), one of the following five categories is selected to describe the findings. These categories refer to the strength of the experimental evidence and not to potency or mechanism.

- **Clear evidence** of carcinogenic activity is demonstrated by studies that are interpreted as showing a dose-related (i) increase of malignant neoplasms, (ii) increase of a combination of malignant and benign neoplasms, or (iii) marked increase of benign neoplasms if there is an indication from this or other studies of the ability of such tumors to progress to malignancy.
- **Some evidence** of carcinogenic activity is demonstrated by studies that are interpreted as showing a chemical-related increased incidence of neoplasms (malignant, benign, or combined) in which the strength of the response is less than that required for clear evidence.
- **Equivocal evidence** of carcinogenic activity is demonstrated by studies that are interpreted as showing a marginal increase of neoplasms that may be chemical related.
- **No evidence** of carcinogenic activity is demonstrated by studies that are interpreted as showing no chemical-related increases in malignant or benign neoplasms.
- **Inadequate study** of carcinogenic activity is demonstrated by studies that, because of major qualitative or quantitative limitations, cannot be interpreted as valid for showing either the presence or absence of carcinogenic activity.

For studies showing multiple chemical-related neoplastic effects that if considered individually would be assigned to different levels of evidence categories, the following convention has been adopted to convey completely the study results. In a study with clear evidence of carcinogenic activity at some tissue sites, other responses that alone might be deemed some evidence are indicated as “were also related” to chemical exposure. In studies with clear or some evidence of carcinogenic activity, other responses that alone might be termed equivocal evidence are indicated as “may have been” related to chemical exposure.

When a conclusion statement for a particular experiment is selected, consideration must be given to key factors that would extend the actual boundary of an individual category of evidence. Such consideration should allow for incorporation of scientific experience and current understanding of long-term carcinogenesis studies in laboratory animals, especially for those evaluations that may be on the borderline between two adjacent levels. These considerations should include:

- adequacy of the experimental design and conduct;
- occurrence of common versus uncommon neoplasia;
- progression (or lack thereof) from benign to malignant neoplasia as well as from preneoplastic to neoplastic lesions;
- some benign neoplasms have the capacity to regress but others (of the same morphologic type) progress. At present, it is impossible to identify the difference. Therefore, where progression is known to be a possibility, the most prudent course is to assume that benign neoplasms of those types have the potential to become malignant;
- combining benign and malignant tumor incidence known or thought to represent stages of progression in the same organ or tissue;
- latency in tumor induction;
- multiplicity in site-specific neoplasia;
- metastases;
- supporting information from proliferative lesions (hyperplasia) in the same site of neoplasia or in other experiments (same lesion in another sex or species);
- presence or absence of dose relationships;
- statistical significance of the observed tumor increase;
- concurrent control tumor incidence as well as the historical control rate and variability for a specific neoplasm;
- survival-adjusted analyses and false positive or false negative concerns;
- structure-activity correlations; and
- in some cases, genetic toxicology.

**NATIONAL TOXICOLOGY PROGRAM BOARD OF SCIENTIFIC COUNSELORS
TECHNICAL REPORTS REVIEW SUBCOMMITTEE**

The members of the Technical Reports Review Subcommittee who evaluated the draft NTP Technical Report on vanadium pentoxide on October 18, 2001, are listed below. Subcommittee members serve as independent scientists, not as representatives of any institution, company, or governmental agency. In this capacity, subcommittee members have five major responsibilities in reviewing the NTP studies:

- to ascertain that all relevant literature data have been adequately cited and interpreted,
- to determine if the design and conditions of the NTP studies were appropriate,
- to ensure that the Technical Report presents the experimental results and conclusions fully and clearly,
- to judge the significance of the experimental results by scientific criteria, and
- to assess the evaluation of the evidence of carcinogenic activity and other observed toxic responses.

Stephen S. Hecht, Ph.D., Chairperson
University of Minnesota Cancer Centers
Minneapolis, MN

Linda A. Chatman, D.V.M.*
Pfizer, Inc.
Groton, CT

Harold Davis, D.V.M., Ph.D.*
Preclinical Safety Assessment
Amgen, Inc.
Thousand Oaks, CA

Yvonne P. Dragan, Ph.D.*
School of Public Health
Ohio State University
Columbus, OH

Norman R. Drinkwater, Ph.D.
McArdle Laboratory for Cancer Research
University of Wisconsin-Madison
Madison, WI

James E. Klaunig, Ph.D.*
Division of Toxicology
Department of Pharmacology and Toxicology
Indiana University/Purdue University at Indianapolis
Indianapolis, IN

David E. Malarkey, D.V.M., Ph.D., Principal Reviewer
Department of Microbiology, Pathology, and Parasitology
College of Veterinary Medicine
North Carolina State University
Raleigh, NC

Michele Medinsky, Ph.D., Principal Reviewer
Durham, NC

Walter W. Piegorsch, Ph.D.
Department of Statistics
University of South Carolina
Columbia, SC

Mary Anna Thrall, D.V.M., Principal Reviewer
Department of Pathology
College of Veterinary Medicine and Biomedical Sciences
Colorado State University
Fort Collins, CO

* Did not attend

SUMMARY OF TECHNICAL REPORTS REVIEW SUBCOMMITTEE COMMENTS

On October 18, 2001, the draft Technical Report on the toxicology and carcinogenesis studies of vanadium pentoxide received public review by the National Toxicology Program's Board of Scientific Counselor's Technical Reports Review Subcommittee. The review meeting was held at the National Institute of Environmental Health Sciences, Research Triangle Park, NC.

Dr. N.B. Ressa, NIEHS, introduced the toxicology and carcinogenesis studies of vanadium pentoxide by discussing the uses of the chemical and the rationale for study, describing the experimental design, reporting on survival and body weight effects, and commenting on compound-related neoplastic and nonneoplastic lesions. The proposed conclusions for the 2-year inhalation studies were *some evidence of carcinogenic activity* of vanadium pentoxide in male F344/N rats and *equivocal evidence of carcinogenic activity* of vanadium pentoxide in female F344/N rats based on the occurrence of alveolar/bronchiolar neoplasms. There was *clear evidence of carcinogenic activity* of vanadium pentoxide in male and female B6C3F₁ mice based on increased incidences of alveolar/bronchiolar neoplasms.

Dr. T.R. Devereux, NIEHS, described studies to characterize the pattern of *K-ras* mutations in lung carcinomas taken from mice exposed to vanadium pentoxide. Nearly 75% of these carcinomas exhibited *K-ras* mutations, compared to a rate of about 30% in spontaneously occurring alveolar/bronchiolar carcinomas from untreated mice. In addition, many of the tumors with *K-ras* mutations exhibited a loss of heterozygosity at chromosome 6 in the region of the *K-ras* suppressor gene. Samples with both the *K-ras* mutation and loss of heterozygosity also had the highest activity of MAP kinase. Taken together, these findings were suggestive of a mechanism for the carcinogenicity of vanadium pentoxide.

Dr. Medinsky, a principal reviewer, agreed with the proposed conclusions and commented on the discussion of the toxicokinetic modeling. She suggested that the area under the lung burden versus time curve might be a better metric for expressing exposure than deposition rates, particularly for use in comparisons of exposures between different rodent species and humans.

Dr. Malarkey, the second principal reviewer, also agreed with the proposed conclusions and commended the inclusion of several supplemental studies, including immunotoxicology, reproductive toxicology, and pulmonary lavage. He inquired whether decreases in heart rate and blood pressure might have been secondary effects of the pulmonary disease and if uterine stromal polyps should be included in the list of chemical-related neoplasms.

Dr. Thrall, the third principal reviewer, also agreed with the proposed conclusions. She suggested that the observed erythrocytosis may have been due to hypoxemia secondary to the lung disease.

Dr. Ressa clarified that the lung burden measures were based on weighing entire lungs rather than extrapolation from measurements from samples. Regardless of the metric, mice were seen to be more sensitive than rats to vanadium pentoxide. Dr. Medinsky added that one benefit of the measures that factor lung clearance and solubility is that evaluation of dose-setting and comparisons with human studies become more realistic.

Dr. J.R. Hailey, NIEHS, explained that uterine stromal polyps occur spontaneously fairly often and the incidence in the highest exposure group was not statistically significant, so these tumors were not considered related to chemical administration.

Ms. M. Marrapese, representing the Vanadium Committee of the Ferroalloys Association, questioned whether the conclusion for the male rat study might more appropriately be *equivocal evidence* given the lack of statistical significance of the lung tumors. Dr. Malarkey noted that the incidence of tumors in the chamber control group was unusually high compared with the historical control incidence and reduced the statistical significance of the increase in tumors in the exposed groups. Dr. Ressa presented a slide comparing the incidences of lung adenomas in the present studies with several other NTP male rat studies for which conclusions of *some evidence* or *equivocal evidence* were based on lung tumors. The incidences in the vanadium pentoxide study were even higher than in studies of cobalt sulfate and nickel oxide, which were judged *some evidence*, and markedly higher than in other studies with calls of *equivocal evidence*.

Dr. Hailey added that the occurrence of carcinomas in seven vanadium pentoxide exposed animals, compared with only two in over 600 historical control males, provided further support of a chemical-related effect.

Ms. Marrapese also asked that the panel consider deferring the review if they felt they needed more time for

public comment to arrive at a conclusion. No motion to defer was offered.

Dr. Medinsky moved, and Dr. Malarkey seconded, that the conclusions to the report be accepted as written. The motion was approved unanimously with five votes.

INTRODUCTION



VANADIUM PENTOXIDE

CAS No. 1314-62-1

Chemical Formula: V_2O_5 Molecular Weight: 181.88

Synonyms: Divanadium pentoxide; vanadic anhydride; vanadium (5) oxide; vanadium oxide; vanadium pentaoxide

CHEMICAL AND PHYSICAL PROPERTIES

Vanadium pentoxide is an odorless, yellow to reddish-brown orthorhombic crystal. It has a melting point of 690° C, a specific gravity of 3.357 at 18° C, and essentially no vapor pressure at 20° C. It decomposes when boiled at 1,750° C. Vanadium pentoxide is insoluble in alcohol, has a water solubility of 1 g/125 mL, and is soluble in concentrated acid, alkalies (forming vanadates), and acetone (*Patty's*, 1981; *Merck Index*, 1996; Lewis, 1997).

Vanadium exists in several oxidation states, from -2 to +5 (Crans *et al.*, 1998). In the environment it is present in the +3, +4, and +5 oxidation states, with vanadium (V) being the most prevalent form (Nriagu, 1998). Vanadium forms particles in the air and settles in the soil and sediments as vanadium oxides and metal complexes. In water, vanadium pentoxide hydrolyzes to form vanadate solutions (Crans *et al.*, 1998). In humans and other mammals, vanadium (V) is reduced to vanadium (IV), and it is considered an essential nutritional element in chickens and rats and probably humans (Crans *et al.*, 1998; Hamel, 1998).

PRODUCTION, USE, AND HUMAN EXPOSURE

Vanadium is recovered from ores through a series of acid-leaching processes or a roast-quench-leach process that produces red cake which is 85% to 90% pure vanadium pentoxide. Red cake is purified by dissolving it in an aqueous solution of sodium carbonate and ammonium chloride to produce 99.8% pure vanadium pentoxide (*Patty's*, 1981). It is also prepared by igniting ammonium metavanate (*Kirk-Othmer*, 1983).

Vanadium pentoxide is the principal starting material for the production of vanadium compounds (Nriagu, 1998). Vanadium pentoxide is used as a chemical intermediate in the production of vanadium and steel alloys (Lagerkvist *et al.*, 1986; Wexler, 1998). Vanadium pentoxide is a catalyst in the oxidation of sulfide to sulfate and alcohol to acetaldehyde. It is used in catalytic converters, for the manufacture of yellow glass that inhibits transmission of ultraviolet light, and in photographic developing solutions. Vanadium pentoxide is used in the production of aniline black dye, to dye ceramics, and as a mordant in coloring textiles (Lewis, 1997).

In 1990, an estimated 3.7×10^5 lbs of vanadium pentoxide was imported into the United States, and exportation averaged 1.9×10^6 lbs. Total world production of vanadium metal in 1978 was 31,889 metric tons, and in 1985, anticipated capacities were 63,321 metric tons. The estimated United States production and demand for the year 2000 are 8,800 metric tons and less than 16,000 metric tons, respectively (*Kirk-Othmer*, 1983).

The National Occupational Exposure Survey (1981-1983) reported that approximately 5,000 employees were potentially exposed to vanadium pentoxide (NIOSH, 1990). Exposure to vanadium pentoxide in the workplace occurs during the cleaning of oil-fired boilers and furnaces, the handling of catalysts in the chemical manufacturing industry, and during the refining, processing, or burning of vanadium-rich mineral ores or fossil fuels (Plunkett, 1987; Zenz, 1994). The time-weighted average threshold limit value for vanadium pentoxide (dust or fume) is 0.05 mg/m^3 (ACGIH, 2001). The Immediately Dangerous to Life or Health Concentration is 35 mg/m^3 as vanadium, the NIOSH recommended exposure limit is 0.05 mg/m^3 , and the OSHA permissible exposure limits are 0.5 mg/m^3 (dust) and 0.1 mg/m^3 (fume) (NIOSH, 1997).

Total global emission of vanadium to the atmosphere ranges from 71,000 tons per year to 210,000 tons per year (Crans *et al.*, 1998; Mamane and Pirrone, 1998) with major point sources being metallurgical works (30 to 300 kg vanadium/ton vanadium produced), oil burning, and coal burning (0.2 to 2 kg/1,000 tons) (Lagerkvist *et al.*, 1986). The vanadium concentration in crude oil, residual fuel oil, and asphaltene ranges from less than 0.3 to 1,180 ppm, with Venezuelan oil having the highest vanadium concentration, and the most common form being in the +4 oxidation state. The burning of these fuels produces significant amounts of vanadium pentoxide and fly ash (vanadium content ranging from 100 to 1,000 $\mu\text{g/g}$) (Mamane and Pirrone, 1998). In the rural and urban United States, estimates of airborne vanadium concentration range from 5 to $1,230 \text{ ng/m}^3$, with the highest being in heavily industrialized cities; more recent United States estimates range from 0.3 to 65 ng/m^3 (WHO, 1988). Vanadium has been detected in potatoes (1.5 mg/kg), milk (0.2 to 10 $\mu\text{g/kg}$), meat (1 $\mu\text{g/kg}$), drinking water (approximately 4.3 $\mu\text{g/L}$), and soil (5 to 140 mg/kg). In human tissue, the total vanadium concentration is approximately 0.3 $\mu\text{g/g}$ (*Patty's*, 1981).

Vanadium pentoxide and other vanadium compounds have been investigated as glucose-lowering agents in the management of diabetes, antihypertensive agents, and anorexigenic agents (Madsen *et al.*, 1993; Zaporowska, *et al.*, 1993; Poucheret *et al.*, 1998; Cam *et al.*, 2000; Crans, 2000; Goldfine *et al.*, 2000; Srivastava, 2000; Sun *et al.*, 2000).

ABSORPTION, DISTRIBUTION, METABOLISM, AND EXCRETION

Experimental Animals

A number of studies have investigated the uptake of vanadium pentoxide and other vanadium compounds following various routes of administration. In general, the absorption, distribution, and elimination of vanadium pentoxide and other vanadium compounds are similar. However, there are variations depending on the route of exposure and the form of vanadium administered, with most of the differences relating to solubility of other vanadium compounds. In general, there are no differences in the uptake and distribution of vanadium among rat strains. However, Mravcová *et al.* (1993) reported significantly greater concentrations of vanadium (from sodium orthovanadate) in male and female weanling rats compared to adults and in weanling males compared to age-matched females when administered by a single subcutaneous injection on days 1, 3, and 10 postexposure.

In rats exposed to ammonium metavanadate by nose-only inhalation, 40% of vanadium was cleared from the lungs within 24 hours (Cohen *et al.*, 1996). Earlier time points have been investigated in rats intratracheally instilled with vanadium pentoxide. Up to 50% of vanadium was cleared from the lungs within 1 hour, and after this initial rapid clearance, the second-phase half-life for the lung was 1.8 days with 3% remaining in the lung up to 68 days postexposure (Oberg *et al.*, 1978; Conklin *et al.*, 1982; Rhoads and Sanders, 1985). The first-phase whole-body clearance of vanadium pentoxide was 11 hours and the second phase was 51 days (Rhoads and Sanders, 1985). Although vanadium pentoxide follows a simple first-order elimination from the lung, the more soluble sodium orthovanadate was eliminated more rapidly and did not appear to follow a straight first-order profile (Sharma *et al.*, 1987). Up to 20% of the recovered vanadium pentoxide was detected in the blood 1 hour after exposure (Conklin *et al.*, 1982; Rhoads and

Sanders, 1985). Vanadium pentoxide is primarily deposited in the liver, kidney, bone, and spleen, with most of the deposition occurring in the bone. Vanadium pentoxide was rapidly eliminated from all organs except bone. Vanadium was detected in bones 9 weeks after exposure (Oberg *et al.*, 1978; Conklin *et al.*, 1982; Rhoads and Sanders, 1985; Ramanadham *et al.*, 1991). Similar distribution patterns have been observed for more soluble vanadium compounds, such as sodium orthovanadate and vanadyl chloride; these compounds were more rapidly distributed and eliminated from tissues (Conklin *et al.*, 1982; Sharma *et al.*, 1987).

When vanadium pentoxide was administered by gavage to rats, only 2.6% of the vanadium was absorbed. However, it was distributed in the same manner as that observed following intratracheal administration, with most of the vanadium being deposited in bone (Conklin *et al.*, 1982). Following subcutaneous administration to weanling and adult rats, vanadium (from sodium orthovanadate) was rapidly absorbed and distributed to the kidney, spleen, and bone, with up to 60% of the dose detected in the bone within 24 hours. In pregnant rats administered vanadium pentoxide by intraperitoneal injection on gestation days 6 through 18, significantly greater concentrations of vanadium were detected in the placenta and fetus compared to those in the controls. Vanadium pentoxide was not detected in the amniotic fluid (Li *et al.*, 1991; Zhang *et al.*, 1991).

Humans

Vanadium (unspecified molecular form) was reported to be absorbed rapidly following inhalation exposure but was poorly absorbed through dermal contact or when ingested (Ryan *et al.*, 1999). When vanadium is administered orally, 0.1% to 1% is absorbed from the gut, although absorption increases with the solubility of vanadium. It is reported that 60% of absorbed vanadium is excreted by the kidneys within 24 hours (Wexler, 1998). When absorbed, vanadium (IV) and (V) reversibly bind to transferrin in the blood and are taken into erythrocytes (Ryan *et al.*, 1999). Based on autopsy cases, vanadium is distributed to the lungs and intestine; vanadium was not detected in the heart, aorta, brain, kidney, muscle, ovary, or testes; however, the methods for detection were reported to be insensitive (Ryan *et al.*, 1999).

Urine and serum vanadium concentrations have been measured in workers exposed to vanadium pentoxide. Vanadium was detected in the urine of workers (62 µg

vanadium/g creatinine) directly exposed to vanadium pentoxide dust at concentrations up to 1 mg/m³ (Barbier and Teulon, 1989; Kawai *et al.*, 1989). The concentration of vanadium in the urine and serum of workers involved in the processing of vanadium pentoxide decreased with time spent away from work (Kiviluoto *et al.*, 1981). Urine concentrations were 32, 20, and 22 µg vanadium/g creatinine on days 1, 3, and 16, respectively, and serum concentrations were 393 and 225 nmol vanadium/L on days 1 and 16. The results suggest an initial rapid clearance followed by a second slower excretion of vanadium.

Kučera *et al.* (1992) measured vanadium levels in the hair and blood of people living near a metallurgical plant. Vanadium levels in the hair did not differ significantly from the control population; however, vanadium concentrations in the blood of exposed children (median 0.078 µg/L) were significantly greater than those of children not living near a metallurgical plant (median 0.042 µg/L).

TOXICITY

Experimental Animals

There is little information in the literature on the toxicity of vanadium pentoxide in animals, especially by inhalation exposure. The acute toxicity values for vanadium pentoxide and selected vanadium compounds are summarized in Table 1. The acute toxicity values for vanadium pentoxide are similar across routes and species, and vanadium pentoxide is similar in toxicity to ammonium metavanadate (NH₄VO₃) administered subcutaneously or intravenously, but not through the oral route. Vanadium pentoxide appears to be more acutely toxic than other vanadium compounds.

As in humans, the respiratory tract is the major target for vanadium pentoxide toxicity in animals exposed by inhalation. In general, acute toxic effects in animals exposed to vanadium pentoxide by inhalation include pulmonary edema, bronchopneumonia, fibrosis, bronchitis, rhinitis, hemorrhagic lung inflammation, tracheitis, and emphysema. The main differences between acute and chronic effects of vanadium pentoxide are the development of chronic inflammation in the bronchi, atelectasis, septic bronchopneumonia, interstitial infiltration and proliferation, and emphysema (WHO, 1988).

Inhalation of vanadium pentoxide is known to cause irritation of the respiratory system and alterations in

TABLE 1
Acute Toxicity Values for Vanadium Compounds in Experimental Animals

Compound	Species	Dose/Exposure	Route	Parameter
V ₂ O ₅ ^a	Rat	70 mg/m ³ /2 hours	Inhalation	LC _{Lo}
	Cat	500 mg/m ³ /23 minutes	Inhalation	LC _{Lo}
	Rat	12 mg/kg	Intraperitoneal	LD ₅₀
	Rat	14 mg/kg	Subcutaneous	LD ₅₀
	Rat	10 mg/kg	Oral	LD ₅₀
	Mouse	10 mg/kg	Subcutaneous	LD ₅₀
	Mouse	23 mg/kg	Oral	LD ₅₀
NH ₄ VO ₄ ^b	Rat ^c	160 mg/kg	Oral	LD ₅₀
	Rat	20 - 30 mg/kg	Subcutaneous	LD ₅₀
	Mouse	25 - 30 mg/kg	Subcutaneous	LD ₅₀
	Rabbit	1.5 - 2 mg/kg	Intravenous	LD ₅₀
	Guinea pig	1 - 2 mg/kg	Subcutaneous	LD ₅₀
Na ₃ VO ₄ ^d	Rat _b	330 mg/kg	Oral	LD ₅₀
	Rat	50 - 60 mg/kg	Subcutaneous	LD ₅₀
	Mouse	36 mg/kg	Intraperitoneal	LD ₅₀
	Mouse _b	50 mg/kg	Subcutaneous	LD _{Lo}
	Rabbit ^b	2 - 3 mg/kg	Intravenous	LD ₅₀
	Guinea pig ^b	1 - 2 mg/kg	Subcutaneous	LD ₅₀
Na ₃ VO ₃ •H ₂ O ^e	Mice	11 mg/kg	Intraperitoneal	LD ₅₀
VOCl ₃ ^a	Rat	140 mg/kg	Oral	LD ₅₀
V ₂ O ₃ ^e	Mice	130 mg/kg	Oral	LD ₅₀
VCl ₂ ^a	Rat	540 mg/kg	Oral	LD ₅₀
VCl ₄ ^a	Rat	160 mg/kg	Oral	LD ₅₀
VCl ₃ ^a	Rat	350 mg/kg	Oral	LD ₅₀
	Mice ^e	23 mg/kg	Oral	LD ₅₀
	Rabbit	20 mg/kg	Subcutaneous	LD _{Lo}

^a Lewis, 2000

^b Faulkner Hudson, 1964

^c HSDB, 2001

^d RTECS, 2001

^e Patty's, 1981

pulmonary function, and it is associated with occupation-induced asthma in humans. Studies reported in the literature have investigated these changes in animals following whole-body exposure to vanadium pentoxide. Kyono *et al.* (1999) exposed male Wistar rats having acute bronchiolitis (induced by nickel aerosol) to a concentration of 2.2 mg/m³ vanadium pentoxide for 5 hours [mass median aerodynamic diameter (MMAD)=1.1 µm]. Rats with bronchiolitis had delayed recovery from preexisting lesions, exacerbated inflammation, and reduced clearance of vanadium pentoxide compared to rats without bronchiolitis.

Knecht *et al.* (1985) conducted experiments in male cynomolgus monkeys exposed to 0.5 or 5 mg/m³ vanadium pentoxide by whole-body inhalation for 1 week (MMAD approximately 0.6 µm). Impairment in pulmonary function, as indicated by air-flow limitations in the large central and peripheral airways, and increases in the total number of cells in bronchiolar lavage fluid were consistent with an inflammatory reaction in the 5 mg/m³ group. No effects were observed in the 0.5 mg/m³ group. Similar, but more immediate, effects on pulmonary function were observed in monkeys exposed to sodium vanadate. Methacholine (a bronchoconstrictor) challenges conducted before inhalation did not predict the severity of the pulmonary function changes in response to acute vanadium pentoxide and sodium vanadate exposures.

To investigate pulmonary reactivity to vanadium pentoxide following subchronic exposure, male cynomolgus monkeys were exposed to 0.1 mg/m³ (with a peak of 1.1 mg/m³) or to 0.5 mg/m³ vanadium pentoxide by whole-body inhalation for 26 weeks (Knecht *et al.*, 1992). Provocation challenges to vanadium pentoxide were performed at concentrations of 0.5 and 3 mg/m³ before and after the 26-week exposure. Preexposure challenge to 3 mg/m³, but not 0.5 mg/m³, caused impairment in pulmonary function characterized by airway obstructive changes resulting from an influx of inflammatory cells in the lung. Following the 26-week exposure to vanadium pentoxide, pulmonary reactivity of exposed groups was not different from that of the control group; instead, a trend toward decreased reactivity was observed suggesting the monkeys developed a tolerance to vanadium pentoxide.

In order to evaluate the extent and possible mechanism of vanadium pentoxide-induced respiratory toxicity, a number of studies have been conducted utilizing intra-

tracheal instillation. Female CD rats were instilled with 42 or 420 µg vanadium pentoxide/kg body weight or 21 or 219 µg/kg as vanadyl sulfate trihydrate (VOSO₄ • 3H₂O), and sodium metavanadate (NaVO₃) in saline (Pierce *et al.*, 1996). Significant increases in neutrophils recovered by bronchoalveolar lavage were observed 4 hours after exposure to the soluble vanadates and 24 hours after exposure to vanadium pentoxide. Levels remained significantly increased for all compounds through 48 hours, and with the exception of vanadyl sulfate trihydrate, returned to control values by day 5. Vanadium was rapidly cleared (within 2.5 hours postexposure) from the lung, lavage fluid, and bronchoalveolar lavage cells of rats treated with vanadyl sulfate trihydrate; the clearance of other vanadium compounds was not determined.

Male Wistar rats were intratracheally instilled with 0.56 mg/kg vanadium pentoxide once per month for 12 months (Zychlinski *et al.*, 1991). A slight decrease in mean body weights of treated rats was observed at 11 and 12 months, and a 60% increase in absolute lung weights was observed at the end of the study. *In vitro* studies were performed in rat lung microsomes treated with vanadate to explain the mechanism of toxic effects observed in the lungs of rats exposed to vanadium pentoxide. *In vitro* studies showed that vanadium (V) undergoes redox cycling and initiates lipid peroxidation that may be responsible for pulmonary toxicity.

Bonner *et al.* (2000) showed that after a single intratracheal instillation of 1 mg/kg vanadium pentoxide, male Sprague-Dawley rats that were followed for 2 weeks developed constrictive airway pathology consistent with asthma-like effects in rodents and humans. These effects included airway smooth muscle cell thickening, mucous cell metaplasia, and fibrosis. Mucous cell metaplasia, characterized by differentiation of 30% to 40% of airway epithelial cells to goblet cells, was observed 6 days after exposure. The appearance of peribronchiolar myofibroblasts, which peaked by day 6, coincided with an increase in airway smooth muscle cell mass. These events were related to airway narrowing and promotion of fibrosis.

Myofibroblast proliferation is an important event in pulmonary fibrogenesis. PDGF-R α , a potent mitogen for mesenchymal cells, was induced during the inflammatory and early proliferative stages of fibrogenesis (24 hours postexposure) in male Sprague-Dawley rats

intratracheally instilled with 2 mg/kg vanadium pentoxide (Bonner *et al.*, 1998). The suggestion that this response was associated with increased myofibroblast proliferation in the fibrotic lung was supported by *in vitro* experiments showing upregulation of PDGF-R α in cultured alveolar macrophages that was likely due to IL-1 β activity (Bonner *et al.*, 1998). In addition, the progression of pulmonary fibrogenesis in male Sprague-Dawley rats exposed to 1 mg/kg vanadium pentoxide was inhibited through the use of tyrosine kinase inhibitors specific for the PDGF and epidermal growth factor receptors; these results suggest that growth factor receptors are likely involved in the proliferation of collagen-producing myofibroblasts in the lung (Rice *et al.*, 1999).

Other studies have been performed by other routes of exposure or using more soluble vanadium compounds. Male Fischer 344 rats were exposed to 2 mg/m³ ammonium metavanadate (0.32 μ m in diameter) through nose-only inhalation 8 hours per day for 4 days (Cohen *et al.*, 1996). Significant increases in neutrophil numbers, numbers of small (<15 μ m diameter) macrophages, total lavaged protein, and lactate dehydrogenase values were observed on day 4. Vanadium also altered the ability of pulmonary alveolar small macrophages to produce and respond to immunoregulating cytokines. In *ex vivo* studies using macrophages isolated from lavage fluid of treated rats, reduced production of TNF- α and cell-surface class I/I-A molecules in response to interferon- γ was observed.

In another study, weanling and adult ICR mice and Wistar rats were exposed to 6 mg/kg vanadium pentoxide by gavage 5 days per week for 15 weeks or to 1 or 100 mg/L vanadium pentoxide in drinking water for 6 months, respectively (Mravcová *et al.*, 1993). In exposed mice, spleen weights, leukocytes, natural killer cells, plaque-forming cells, and phytohemagglutinin responsiveness were significantly greater than those in the controls. In rats exposed to 100 mg/L, spleen weight and concanavalin A responsiveness were significantly greater than those in the controls; in rats exposed to 1 mg/L, phytohemagglutinin responsiveness and concanavalin A were significantly elevated. These results indicate activation of T and B cell immune responses.

Female B6C3F₁ mice were exposed intraperitoneally to 2.5, 5, or 10 mg/kg ammonium metavanadate 3 days per week for 3, 6, or 9 weeks. Two days after dosing, mice were exposed to *Escherichia coli* lipopolysaccharide

endotoxin and evaluated for changes in immune response. Vanadium treatment was protective against lipopolysaccharide toxicity and lethality in a dose-dependent manner. However, resistance to *Listeria monocytogenes* decreased in vanadium-treated mice in a time- and dose-dependent manner. Vanadium did not affect the viability of peritoneal macrophages but did decrease phagocytic activity of macrophages at high doses after 3 weeks of treatment and at all doses after 6 weeks of treatment. Relative liver and spleen weights increased and thymus weights decreased in treated mice; body weights were not affected (Cohen *et al.*, 1986).

The potential toxicity of reactive oil fly ash (ROFA), which contains vanadium and other metals, has been investigated in a series of studies using male Sprague-Dawley rats exposed to ROFA by intratracheal administration. Dreher *et al.* (1997) evaluated the toxicity of ROFA (MMAD=1.95 μ m) leachates and a neat suspension of nickel (1 μ mol), iron (0.53 μ mol), and vanadium (1.76 μ mol) in saline at similar concentrations. Rats exposed to ROFA and the metal mixture developed severe pulmonary inflammation, indicated by recruitment of neutrophils, eosinophils, and monocytes. Depletion of iron, nickel, and vanadium from the ROFA leachate eliminated its pulmonary toxicity, indicating that transition metals are the causative agents of ROFA-induced lung injury. In another study, Kodavanti *et al.* (1998) showed that pulmonary responses to ROFA differ based on metal content. An association was observed between pulmonary inflammation (indicated by increased neutrophils in lavage fluid) and water-leachable vanadium, while protein leakage was associated with water-leachable nickel. Gavett *et al.* (1997) also showed that the severity of ROFA-induced lung injury and airway hyperreactivity varied based on the metal content of the ROFA leachates. Pulmonary reactivity to acetylcholine and early changes suggestive of fibrosis were more severe in rats exposed to ROFA with high zinc content than in rats exposed to ROFA leachates with nickel, vanadium, sulfate, and iron.

To investigate the mechanism of ROFA-induced lung injury, severe pulmonary edema was induced in rats exposed to ROFA leachate containing 188 mg/mL vanadium (Silbajoris *et al.*, 2000). Immunohistochemistry of lung sections showed an increase in levels of phosphorylated protein tyrosine-kinase and mitogen-activated protein kinase in the alveolar epithelium and in inflammatory cells, suggesting activation of cell-signaling pathways in response to lung damage.

Humans

The health effects of vanadium pentoxide and other vanadium compounds have been investigated since the early 1900s. Health effects attributed to vanadium pentoxide exposure have included bronchitis (often called boilermakers' bronchitis), pneumonia, rhinitis, pharyngitis, laryngitis, and conjunctivitis. Green discoloration of the tongue is a common indicator of exposure to vanadium pentoxide and is often seen in exposed workers (Faulkner Hudson, 1964).

More recent epidemiology evaluations and studies have investigated symptoms in workers and human volunteers exposed to vanadium pentoxide. During the conversion of a power plant from oil to coal, boilermakers exposed to vanadium pentoxide concentrations of 0.05 to 5.3 mg/m³ developed severe respiratory tract irritation with productive cough, sore throat, dyspnea on exertion, and chest pain. Pulmonary function tests performed several days after exposure indicated the possibility of an obstructive effect on the small airways as evidenced by reduced median forced vital capacity and median forced expiratory and median forced midexpiratory flow rates (Levy *et al.*, 1984). Similar symptoms were observed in other exposed boilermakers (Ross, 1983).

The upper airway response in boilermakers exposed to vanadium pentoxide dust concentrations of up to 139 µg/m³ was investigated. Nasal lavage analysis performed after exposure revealed a significant increase in polymorphonuclear cells in nonsmokers, but not in smokers, indicating that exposure to vanadium causes upper airway inflammation (Hauser *et al.*, 1995a).

The lower airway response was investigated in boilermakers exposed to vanadium concentrations of 2.2 to 31.3 µg/m³ (mean 12.2 µg/m³) and a particulate matter (PM₁₀) of 1.44 to 6.69 µg/m³ while repairing an oil-powered boiler (Hauser *et al.*, 1995b). Preexposure and postexposure spirometry readings and methacholine challenge tests were performed. Ninety-two percent of the subjects exhibited a drop in forced expiratory volume that was related to PM₁₀ exposure but not vanadium exposure. There was no postexposure change in non-specific airway responsiveness.

In another study, boilermakers exposed to PM₁₀ concentrations of approximately 0.5 mg/m³ and vanadium concentrations of 1.2 to 8.9 mg/m³ reported both upper and lower airway symptoms (Woodin *et al.*, 2000). A dose-response relationship was observed between symptoms

of exposure and vanadium concentrations in the lung and nasal cavity and PM₁₀ concentrations in the lungs. PM₁₀ concentration was a strong predictor of upper airway symptoms, and vanadium concentration was a strong predictor of lower airway symptoms.

Workers from the enameling and decorating industry were evaluated for dermatitis and contact sensitization (Motolese *et al.*, 1993). Only 1 of 170 workers exhibited sensitization to vanadium pentoxide after it was administered by skin patch at concentrations up to 10% in petrolatum.

In a controlled vanadium exposure evaluation, nine volunteers were exposed to vanadium pentoxide dust for 8-hour periods. Two volunteers were accidentally exposed to 1 mg/m³ vanadium pentoxide dust for 8 hours. During this period, these subjects developed a frequent cough, but no other signs of irritation were present. Three weeks later, these same subjects were exposed for 5 minutes to a heavy cloud of vanadium pentoxide; they developed marked coughing, productive sputum, rales, and expiratory wheezes within 16 hours. Other volunteers were exposed to 0.25 to 0.5 mg/m³. The next morning, all subjects developed a productive cough that lasted as long as 10 days. Despite distinct clinical pulmonary irritation, pulmonary function tests were normal for all subjects (Zenz and Berg, 1967).

An epidemiology study was performed to assess the health effects in children exposed to atmospheric vanadium that originated from the production of vanadium pentoxide from vanadium-rich slag (Lener *et al.*, 1998). No differences were observed at the level of nonspecific immunity. Higher values in the mitotic activity of T lymphocytes were observed, suggesting elevated cellular immunity activity; however, the numbers of viral and bacterial infections also were increased, suggesting a decrease in cellular immunity.

REPRODUCTIVE AND DEVELOPMENTAL TOXICITY

Experimental Animals

A few studies have been conducted in rodents to evaluate the effects of vanadium pentoxide administration on male reproductive capability, females and fetuses during gestation, and postnatal development of pups. Male Swiss CD-1[®] mice were injected intraperitoneally with 8.5 µg vanadium pentoxide/g body weight every 3 days

for 60 days with 10-day interim sacrifices. There was a slight decrease in testis weights on days 50 and 60 and final body weights on day 60. Sperm motility and sperm counts were reduced significantly after 10 and 20 days of treatment, respectively, and remained significantly lower than those of the controls through day 60. Abnormal sperm was observed only on day 60. Twenty-four hours after the last injection, males were allowed to mate. The fertility rate was reduced by 52% compared to the controls. Fetal weights and the numbers of implantation sites and live fetuses were decreased, while the percent resorptions and number of dead fetuses were increased (Altamirano-Lozano *et al.*, 1996).

Zhang *et al.* (1993) exposed pregnant Wistar rats to 3 mg/kg vanadium pentoxide intraperitoneally from gestation days 6 to 15, to 5 mg/kg from gestation days 9 to 12, or to 5 mg/kg on gestation day 9, 10, or 11. Maternal toxicity (reduced body weights) was observed in all rats except those exposed to vanadium on gestation days 9 and 10. On gestation day 11, a significant decrease in the percentage of implants and number of nonlive implants was observed. The numbers of fetal deaths, nonlive implants, and litters with nonlive implants were increased and average crown-rump lengths were decreased in all groups except those exposed on gestation days 9 and 11. Increased incidences of retarded ossification of the bone on gestation day 10 and increased incidences of subcutaneous hemorrhage and visceral anomalies on gestation days 9 and 10 were observed. The most sensitive period for development of teratogenic effects was on gestation day 10, following a single intraperitoneal injection, or on gestation days 9 to 12, following a series of injections.

Pregnant female albino NMRI mice were exposed to 1.1 mg/kg vanadium pentoxide by injection in the tail vein on gestation day 3 or 8. On gestation day 17, animals were euthanized. The number of fetuses with less mature skeletons (no ossification of at least three of the four elements) was significantly greater in mice given vanadium on gestation day 8 (Wide, 1984). The results in mice are consistent with those in rats.

To evaluate the effect of vanadium pentoxide on the development of newborn rats, Altamirano *et al.* (1991) injected newborn male and female CIIZ-V rats intraperitoneally every 2 days with 12.5 mg/kg vanadium pentoxide from birth to 21 days. As part of the study, female rats were also exposed to vanadium pentoxide by intraperitoneal injection from gestation day 21 to the first day of vaginal estrus. In both newborn and adult female rats, no changes in vaginal opening or in the

estrous cycle were observed; however, the ovulation rate was lower in treated adults. Liver, thymus, and submandibular glands were larger in treated adult females but not in newborns. In newborn male rats, significant increases in the weights of the seminal vesicle, thymus, and submandibular gland occurred.

In another study, Zhang *et al.* (1991) exposed timed-pregnant Wistar rats to 0.33, 1, or 3 mg/kg vanadium pentoxide intraperitoneally on days 6 to 15 of gestation. The highest dose was maternally toxic. Increased fetal mortality and external or skeletal malformations and delayed ossification of the bone were observed at 1 and 3 mg/kg.

Other vanadium compounds have been tested for reproductive and developmental toxicity with similar results to that of vanadium pentoxide. Pregnant Swiss mice were exposed to 37.5, 75, or 150 mg/kg vanadyl sulphate pentahydrate by gavage on gestation days 6 to 15 and then killed on day 18. Maternal toxicity occurred at 75 and 150 mg/kg as evidenced by reduced body weight gains and decreased liver and kidney weights. Significant increases in early resorptions per litter and significant decreases in fetal weights and length were observed in all dosed groups (Paternain *et al.*, 1990). Sodium metavanadate was administered intraperitoneally to pregnant Swiss albino mice at a concentration of 25 mg/kg on gestation day 9, 10, 11, or 12, and the mice were killed on day 18 (Bosque *et al.*, 1993). Significant increases in the numbers of resorptions and dead fetuses were observed for each dosing time point, and the effects were most pronounced for day 12. In fetuses from dams dosed on gestation day 12, delayed ossification of the bone was observed. Day 12 appeared to be the most sensitive period for developmental toxicity.

Humans

No information on the reproductive and developmental toxicity of vanadium pentoxide in humans was found in the literature.

CARCINOGENICITY

No carcinogenicity studies of vanadium pentoxide in experimental animals or epidemiology studies in humans were found in the literature.

In vitro

Vanadium (IV) causes DNA strand breaks when incubated with hydrogen peroxide and hydroxylates

2'-deoxyguanosine, forming 8-hydroxy-2'-deoxyguanosine, a common type of oxidative base damage that has been associated with carcinogenicity (Sakurai, 1994; Shi *et al.*, 1996a,b). Shi *et al.* (1997) showed that vanadium is reduced by NADPH and glutathione reductase to vanadium (IV). In this reaction, molecular oxygen is released and reduced to O_2^- . Further reduction of the O_2^- results in the formation of hydrogen peroxide, which then reacts with vanadium (IV) in a Fenton-type reaction to produce a free hydroxyl radical (Shi and Dalal, 1991, 1992, 1993; Shi *et al.*, 1996a,b, 1997).

GENETIC TOXICITY

The mutagenicity of vanadium compounds has been reviewed by Léonard and Gerber (1994). In general, vanadium salts are not mutagenic, nor do they induce structural chromosomal aberrations *in vitro* or *in vivo*. However, spindle fiber disruptions and interference with mitotic enzymes have been seen in plant and animal test systems. Absorption from the gastrointestinal tract is poor (Dimond *et al.*, 1963, cited by Léonard and Gerber, 1994), but inhalation exposure results in better absorption (French and Jones, 1993, cited by Léonard and Gerber, 1994). Access to cells varies with the different oxidation states of vanadium; vanadium pentoxide is fairly easily absorbed into cells (Nechay *et al.*, 1986, cited by Léonard and Gerber, 1994).

Vanadium pentoxide has been studied for mutagenic activity most extensively in mammalian cell systems *in vitro* and *in vivo*; little bacterial gene mutation data are available for this metallic compound. No published *Salmonella* mutagenicity data have been identified. A positive result was obtained with 0.5 M vanadium pentoxide in the *Bacillus subtilis* Rec assay for induction of DNA damage (Kanematsu *et al.*, 1980). No induction of sister chromatid exchanges was observed in cultured human lymphocytes exposed to doses of vanadium pentoxide that ranged from 2 to 6 $\mu\text{g/mL}$ (Roldán and Altamirano, 1990) or Chinese hamster V79 cells treated with 1 to 3 $\mu\text{g/mL}$ (Zhong *et al.*, 1994). Structural chromosomal aberrations were not induced in human lymphocytes treated with up to 6 $\mu\text{g/mL}$ vanadium pentoxide *in vitro* (Roldán and Altamirano, 1990), but a significant increase in the frequency of polyploid cells was observed in this investigation. Zhong *et al.* (1994) observed a high frequency of endoreduplication in V79 cells treated with vanadium pentoxide (1 to 3 $\mu\text{g/mL}$).

Negative results were obtained in micronucleus tests in cultured Syrian hamster embryo cells treated with 10 to 25 $\mu\text{g/mL}$ vanadium pentoxide (Gibson *et al.*, 1997), but positive results were reported in Chinese hamster V79 cells treated with 1 to 3 $\mu\text{g/mL}$ vanadium pentoxide (Zhong *et al.*, 1994). The marked, dose-related increases in the induction of micronuclei in the V79 cells were due entirely to increases in the kinetochore-positive fraction of micronuclei, indicating that the induced micronuclei contained entire chromosomes rather than chromosomal fragments. These results, along with the observations of polyploidy and endoreduplication, are evidence of aneuploidy-inducing events rather than induction of structural chromosomal damage.

Further evidence for the aneugenic capacity of vanadium pentoxide comes from the studies of Ramírez *et al.* (1997), in which vanadium was shown to interfere with microtubule assembly and spindle formation in human lymphocytes *in vitro*. An *in vitro* investigation of cytogenetic effects in human lymphocytes with four other vanadium compounds (sodium metavanadate, sodium orthovanadate, ammonium metavanadate, and vanadyl sulfate) yielded similar results (Migliore *et al.*, 1993). No increases in structural aberrations were noted, but micronucleus frequencies and frequencies of hypoploid cells were significantly increased. Further analysis of the micronuclei using fluorescence *in situ* hybridization techniques employing a centromeric probe revealed that the majority of induced micronuclei contained a centromere. This observation is consistent with the finding of hypoploidy and provides broader evidence of the aneuploidy-inducing action of vanadium compounds. Migliore *et al.* (1993) reported small but significant increases in the frequencies of sister chromatid exchanges at high doses (40 to 80 μM or 7.2 to 14.55 $\mu\text{g/mL}$) with each of the four vanadium compounds they tested in human lymphocytes. These results contrast with the negative results reported by Roldán and Altamirano (1990) and Zhong *et al.* (1994). The latter two studies were limited by toxicity to lower concentrations of vanadium pentoxide.

In addition to aneuploidy-related effects, vanadium pentoxide has been shown to induce DNA damage. Rojas *et al.* (1996) treated human lymphocytes *in vitro* with vanadium pentoxide and measured a significant increase in DNA damage via the single-cell gel electrophoresis (Comet) assay. The authors speculated that because the induced damage, in the form of single strand breaks or

alkali-labile sites, was rapidly repaired (most within the first 45 minutes after exposure), it would not be converted into detectable chromosomal damage. Thus, the authors reconciled the positive results with vanadium pentoxide in the Comet assay with the negative results obtained in assays for induction of structural chromosomal aberrations and sister chromatid exchanges.

In vivo, vanadium pentoxide did not induce sister chromatid exchanges in bone marrow cells of Swiss CD-1[®] mice treated by intraperitoneal injection with 5.75 to 23 mg vanadium pentoxide/kg body weight (Altamirano-Lozano *et al.*, 1993), which is consistent with the negative results for this endpoint seen *in vitro*. Intraperitoneal injection of 5.75 to 23 mg/kg induced DNA damage, as measured by the Comet assay, in testicular cells (Altamirano-Lozano *et al.*, 1996) and in the liver, kidney, lung, spleen, and heart, but not the bone marrow, of male Swiss CD-1[®] mice (Altamirano-Lozano *et al.*, 1999).

STUDY RATIONALE

The National Cancer Institute originally nominated vanadium pentoxide for toxicity and carcinogenicity testing as a result of a metals class study based on the potential for human exposure and absence of chronic toxicity data. In addition, the National Institute for Occupational Safety and Health (NIOSH) and the Occupational Safety and Health Administration selected vanadium pentoxide as a priority chemical because of their broad interest in metal toxicity. More specifically, NIOSH was interested in evaluating pulmonary hypersensitivity of vanadium pentoxide because of the asthma-like effects observed in humans exposed to vanadium pentoxide. Vanadium pentoxide is a toxic and ubiquitous environmental and industrial contaminant that poses considerable potential for human exposure. Inhalation was chosen as the route of exposure for the current 2-year studies because it is the primary route of exposure in humans.

MATERIALS AND METHODS

PROCUREMENT AND CHARACTERIZATION OF VANADIUM PENTOXIDE

Vanadium pentoxide was obtained from Shieldalloy Metallurgical Corporation (Newfield, NJ) in two lots (1210490 and 1210140). Lot 1210490 was used in the 16-day and 3-month studies. Lot 1210140 was used in the 16-day special studies and the 2-year studies. Identity and purity analyses were conducted by the study laboratories and the analytical chemistry laboratories (Midwest Research Institute, Kansas City, MO, for lot 1210490; Research Triangle Institute, Research Triangle Park, NC, for lot 1210140). Reports on analyses performed in support of the vanadium pentoxide studies are on file at the National Institute of Environmental Health Sciences.

Lot 1210490, an orange, crystalline solid, was identified as vanadium pentoxide by the analytical chemistry laboratory using X-ray diffraction (XRD) analyses and infrared and ultraviolet/visible spectroscopy and by the study laboratory using infrared spectroscopy. Lot 1210140, a light orange, crystalline solid, was identified by the analytical chemistry laboratory using infrared and ultraviolet/visible spectroscopy and by the study laboratory using XRD analysis. Infrared spectra were consistent between lots and with the structure of vanadium pentoxide (Nyquist and Kagel, 1971). A representative infrared spectrum of vanadium pentoxide is shown in Figure L1. XRD spectra were consistent with literature spectra (Joint Center for Powder Diffraction Studies/International Centre for Diffraction Data, PDF 41-1426) or with the structure of vanadium pentoxide. XRD analyses of both lots indicated the presence of vanadium pentoxide with no detectable contaminants.

The purity of lot 1210490 was determined by the analytical chemistry laboratory using elemental analyses, weight loss on drying, spark source mass spectrometry, energy-dispersive X-ray (EDX) spectroscopy, and potentiometric titration. The purity of lot 1210140 was determined by the analytical chemistry laboratory using weight loss on drying, potentiometric titration, and

inductively coupled argon plasma spectrometry and by the study laboratory using inductively coupled plasma/atomic emission spectroscopy (ICP/AES). Elemental analyses were performed by Galbraith Laboratories (Knoxville, TN).

For lot 1210490, the result of elemental analysis for vanadium was in agreement with the theoretical value for vanadium pentoxide; carbon and hydrogen were also detected at concentrations of less than 0.5% each. Weight loss on drying indicated less than 0.06% volatile components. Spark source mass spectrometry indicated vanadium as the major component; the principal impurities were barium (170 ppm), iron (110 ppm), calcium (440 ppm), potassium (550 ppm), sulfur (270 ppm), silicon and sodium (approximately 1,100 ppm each), aluminum (260 ppm), and magnesium (340 ppm). The total concentration of all other impurities was 565 ppm. EDX analyses of lot 1210490 indicated the presence of vanadium pentoxide with minor amounts of sulfur, chlorine, and potassium. Potentiometric titration by the analytical chemistry laboratory indicated a purity of $103.1\% \pm 0.7\%$. The overall purity of lot 1210490 was determined to be approximately 99%. The study laboratory confirmed the purity upon receipt using potentiometric titration. The purity was determined to be 100.3% compared to a reference standard.

For lot 1210140, the result of elemental analysis for vanadium was in agreement with the theoretical value for vanadium pentoxide. Weight loss on drying indicated 1.2% water. Potentiometric titration indicated a purity of 99.0%. Results of inductively coupled argon plasma spectrometry indicated no trace elements at a concentration greater than 151 ppm. The overall purity was determined by the analytical chemistry laboratory to be approximately 99%. ICP/AES analysis indicated a purity of 101% of the theoretical value.

The analytical chemistry laboratory analyzed lot 1210140 for particle size using transmission electron microscopy and for agglomeration using polarized light optical microscopy. More than 90% of the individual particles were less than 1 micron in diameter. The

individual particles formed aggregates ranging from 40 to 300 μm in diameter, with an average diameter of 170 μm .

Stability studies were performed by Dust Tech, Inc. (August, NJ), using a Hartmann Dust Explosion Apparatus (U.S. Bureau of Mines, Bruceton Station, PA). Results of these analyses indicated that vanadium pentoxide cannot ignite as a dispersed dust at concentrations up to 2,000 mg/m^3 when subjected to a 12,000 volt AC arc at a maximum of 360 watts. No heat stability studies were performed because literature references indicated that vanadium pentoxide is stable under normal storage temperatures. Stability was monitored by the study laboratory throughout the 16-day and 3-month studies with potentiometric titration and throughout the 16-day special studies and the 2-year studies with ICP/AES. No degradation of the bulk chemical was detected.

AEROSOL GENERATION AND EXPOSURE SYSTEM

For the 16-day and 3-month studies, vanadium pentoxide aerosol generation was based on the principle of pneumatic dispersion and consisted of two major components: a screw feeder (Model 310, Accurate, White Water, WI) that metered vanadium pentoxide powder at a constant rate and a Jet-O-Mizer jetmill (Fluid Energy Corp., Harfield, PA) that used compressed air to disperse the metered powder and form the aerosol (Figure L2). Aerosol leaving the jetmill passed through a one-stage impactor and a vertical elutriator to eliminate or deagglomerate the large particles before entering a plenum and manifold distribution system. The aerosol delivery system consisted of three holding chambers that diluted the aerosol in three stages (Figure L3). A metered amount of diluted aerosol was removed and mixed with conditioned air at the inlet to each exposure chamber to achieve the appropriate exposure concentration. The electrical charge buildup on the aerosol particles was neutralized by mixing the aerosol with high concentrations of bipolar ions, which were generated using a Pulse Gun (Static Control Services, Palm Springs, CA) air nozzle. For the 3-month studies, a transvector air pump was installed at the aerosol inlet to each exposure chamber to provide additional control of the aerosol flow rate and improve stability of the chamber concentration.

The generation and delivery system used in the 16-day special studies and the 2-year studies consisted of a

linear dust feeder, a particle attrition chamber, and an aerosol distribution system (Figure L4). The linear dust feeder, a slide-bar dust-metering device, was composed of a shuttle bar, body, outlet port, and hopper (Figure L5). As the compressed-air-driven shuttle bar slid back and forth during generation, the metering port aligned with the hopper, which served as a reservoir for the bulk chemical, and was filled with a small amount of vanadium pentoxide powder. As the shuttle bar slid to the dispersing position, the metering port aligned with a compressed-air port in the body and a puff of air from this port dispersed the vanadium pentoxide into the particle attrition chamber. Generator output was regulated by adjusting the cadence of the shuttle bar. The particle attrition chamber, designed and fabricated by the study laboratory, used low fluid energy from an air jet tangential to the chamber to deagglomerate the vanadium pentoxide particles. After deagglomeration, the particles were swept into a classification zone where smaller particles exited to the distribution line; larger particles were thrown to the perimeter of the classifier by centrifugal force and were reentrained into the impacting air jet, and the process was repeated until the particles were sufficiently deagglomerated. The aerosol passed through the distribution lines to the exposure chambers. A pneumatic pump designed by the study laboratory was located at each chamber inlet and drew aerosol from the distribution line into the chamber inlet, where it was diluted with conditioned air to the appropriate concentration. Flow through the distribution line was controlled by Air-Vac pumps (Air-Vac Engineering, Milford, CT), and pressure was monitored by photohelic differential pressure gauges (Dwyer Instruments, Inc., Michigan City, IN).

The stainless-steel inhalation exposure chambers (Harford Systems Division of Lab Products, Inc., Aberdeen, MD) were designed so that uniform aerosol concentrations could be maintained throughout the chambers when catch pans were in place. The total active mixing volume of each chamber was 1.7 m^3 .

AEROSOL CONCENTRATION MONITORING

Summaries of chamber aerosol concentrations of vanadium pentoxide are given in Tables L1 through L4. During all studies, chamber aerosol concentrations were monitored with real-time aerosol monitors (RAMs) (Model Ram-S, 16-day and 3-month studies; Model Ram-1, 16-day special studies and 2-year studies; MIE,

Inc., Bedford, MA) that used a pulsed-light-emitting diode in combination with a silicon detector to sense light scattered over a forward angular range of 45° to 95° by particles traversing the sensing volume. The instruments respond to particles 0.1 to 20 µm in diameter. During the 16-day and 3-month studies, an individual monitor was used for each exposure chamber. The voltage output of the online monitors was read and recorded, and the calibration curve was applied to the voltages measured by the RAM to convert the measured voltages to exposure chamber concentrations. For the 16-day special studies and the 2-year studies, the sampling system consisted of a valve that multiplexed each RAM to two or three exposure chambers and to a HEPA filter and/or the control chamber or room; selection of sampling streams and data acquisition from each RAM was remotely controlled by a computer (Gateway 2000, San Diego, CA). Equations for calibration curves were stored in the computers and were used to convert the measured voltages to exposure concentrations.

Each RAM was calibrated daily during the 16-day and 3-month studies by correlating the measured voltage with vanadium pentoxide concentrations determined by gravimetric analysis of glass fiber filters (Gelman Laboratory, Ann Arbor, MI) and one to two times per week during the 2-year studies by ICP/AES or ICP/mass spectrometry analysis of Pallflex® TX40H120WW glass fiber filters (Pallflex Corp., Putnam, CT). The ICP/AES was calibrated for each filter analysis against a vanadium standard provided by the National Institute of Standards Technology.

CHAMBER ATMOSPHERE CHARACTERIZATION

The particle size distribution in each chamber was determined prior to the start of all studies, during the first week of the 16-day and 3-month studies, during the first 2 weeks of the 2-year studies, and monthly during the 3-month and 2-year studies. For the 16-day and 3-month studies, a 10-stage Quartz Crystal Microbalance-based cascade impactor (California Measurements, Inc., Sierra Madre, CA) was used to separate the aerosol particles into sequential size ranges; the mass median aerodynamic diameter was calculated from the corresponding mass fraction of particles at each stage. For the 16-day special studies and the 2-year studies, a Mercer-style seven-stage impactor (In-Tox Products, Albuquerque, NM) was used. The stages (glass coverslips lightly sprayed with silicon) were analyzed by ICP/AES, and

the relative mass collected on each stage was analyzed by probit analysis. The mass median aerodynamic diameters and the geometric standard deviations are given in Tables L5 through L9.

Buildup and decay rates for chamber aerosol concentrations were determined with and without animals present in the chambers. At a chamber airflow rate of 15 air changes per hour, the theoretical value for the time to achieve 90% of the target concentration after the beginning of vapor generation (T_{90}) and the time for the chamber concentration to decay to 10% of the target concentration after vapor generation was terminated (T_{10}) were approximately 15 minutes (16-day and 3-month studies) and 12.5 minutes (16-day special studies and 2-year studies). A T_{90} value of 15 minutes (16-day and 3-month studies) or 12 minutes (16-day special studies and 2-year studies) was selected for each study.

The uniformity of aerosol concentration in the inhalation exposure chambers without animals was evaluated before each of the studies began; concentration uniformity with animals present in the chambers was also measured once during the 16-day studies, the 3-month studies, and the 16-day special studies and every 3 months during the 2-year studies. During the 16-day and 3-month studies, minor excursions in chamber uniformity values (between-port and within-port variability) were observed in one or more exposure chambers, but these excursions had no impact on the studies. Chamber concentration uniformity was acceptable throughout the 16-day special studies and 2-year studies.

The persistence of vanadium pentoxide in the exposure chambers was monitored (following a service period in the 16-day and 3-month studies) overnight after aerosol delivery ceased. No test article was detected following the service period. During the 16-day special studies, the average vanadium pentoxide concentration decayed to 1% of the target concentration within 20 minutes. During the 2-year studies, the average vanadium pentoxide concentration decayed to 1% of the target concentration within approximately 20 minutes during prestudy testing and within approximately 16 (2 mg/m³ rat exposure chamber) or 20 (4 mg/m³ mouse exposure chamber) minutes with animals present in the chambers.

The stability of vanadium pentoxide in the exposure system was tested with XRD analysis. XRD analyses indicated no detectable buildup of degradation products at a detection limit of approximately 1%. In addition, filter

samples collected from the exposure chambers, generator reservoir, and distribution line during the 16-day special studies and the 2-year studies were analyzed by ICP/AES. During the 16-day special studies, copper was detected in generator reservoir samples at a concentration of 0.11% during prestudy testing; the total concentration of trace elements present was less than 0.2% in the distribution lines and exposure chambers and less than 0.3% in the generator reservoirs. All other impurities were present at a total concentration of less than 0.03% in all samples. During the 2-year studies, no impurities with concentrations greater than 0.1% were found in the bulk chemical, in the generator reservoir, or in the 4 mg/m³ chamber. During the first weeks of the 2-year studies, aluminum was detected in the distribution line samples (approximately 0.18%) and the 0.5 mg/m³ chamber sample (approximately 1.6%); no other impurities with concentrations greater than 0.1% were detected in these samples. Aluminum may have been introduced into the test material as a result of abrasion of the aluminum generator reservoir by moving parts. A slide bar was realigned, and after approximately 2 weeks, additional samples were collected and analyzed for the presence of aluminum. The concentrations of aluminum determined in the generator reservoir, distribution line, and chamber samples were less than 0.03%.

16-DAY STUDIES

Male and female F344/N rats and B6C3F₁ mice were obtained from Simonsen Laboratories (Gilroy, CA). On receipt, the rats and mice were 4 weeks old. Animals were quarantined for 12 (rats and immunotoxicology mice) or 13 (core study mice) days and were 6 weeks old on the first day of the studies. Groups of five male and five female rats and mice were exposed to particulate aerosols of vanadium pentoxide at concentrations of 0, 2, 4, 8, 16, or 32 mg/m³, 6 hours plus T₉₀ (15 minutes) per day, 5 days per week for 16 days. Additional groups of 22 male rats and 50 female mice designated for immunotoxicology studies were exposed to 0, 4, 8, or 16 mg/m³ for 16 days. Feed was available *ad libitum* except during exposure periods; water was available *ad libitum*. Rats and mice were housed individually. Clinical findings were recorded daily. Core study animals were weighed initially, on day 7, and at the end of the studies; immunotoxicology study animals were weighed initially and at the end of the studies. Details of the study design and animal maintenance are summarized in Table 2.

For influenza virus challenge analyses, groups of 20 female mice were anesthetized with methoxyfluorane and instilled intranasally with 0.05 mL mouse-adapted influenza A2 Taiwan derived from ATCC VR-480 in sterile phosphate-buffered saline. The mice were observed for 14 days following the virus challenge. At the end of the observation period, all surviving mice were sacrificed by carbon dioxide asphyxiation.

For pulmonary bactericidal activity analyses, groups of 12 male rats and 12 female mice were exposed simultaneously to an aerosol of viable radiolabeled [³⁵S]-*Klebsiella pneumoniae* administered with a Retec X-70 disposable nebulizer (Retec Development Lab, Portland, OR) for 30 minutes. Immediately after the microbial-aerosol exposure, eight rats and six mice per group were sacrificed by carbon dioxide asphyxiation. The remaining animals were sacrificed 3 hours after exposure ceased. The lungs were removed and bacterial counts were determined in a Petroff-Hausser counting chamber by dark-field microscopy and by the culture plate technique. Radiolabel was measured with a Mark III Liquid Scintillation System (T.M. Analytic, Elk Grove Village, IL). Ratios of viable bacteria counts to radioactive counts were used to determine the rate at which bacteria were destroyed 3 hours after inoculation.

For pulmonary lavage analyses, groups of 10 male rats and 10 female mice were sacrificed by intraperitoneal injection of sodium pentobarbital and the lungs were lavaged *in situ* (rats) or excised and lavaged (mice). Alveolar cells were collected from the lavage fluid by centrifugation and resuspended in RPMI-1640 buffer (Whittaker Bioproducts, Walkersville, MD) mixed with 10% low-endotoxin fetal calf serum (Hyclone Labs, Logan, UT) to form RPMI-10. The supernatant from the first two washes was used for total protein and lysozyme activity measurements. To determine protein content, lavage fluids were combined with Coomassie Protein Assay Reagent (Pierce, Rockford, IL), placed in a 96-well plate, and analyzed against bovine serum albumin standards (Pierce) with an ELISA reader (Bio-Tek EL-310, Winooski, VT) at 600 nm. Lysozyme activity was measured against egg white lysozyme standards (Sigma Chemical Co., St. Louis, MO) in a Centrifichem System 500 centrifugal analyzer (Baker Instruments, Allentown, PA). Lavage fluids were mixed with *Micrococcus lysodeikticus* (Sigma) and decreased absorbance was measured at 520 nm. Total and viable

cell counts in the alveolar macrophage preparation were determined using a hemacytometer and cell viability was determined by exclusion of Trypan Blue dye. Cellular distribution was determined using differential counts of cytocentrifuge preparations with methanol-fixed, Wright's-stained cells. Fc receptor-mediated phagocytosis of [⁵¹Cr]-chicken red blood cells (CRBC) by rat macrophages was determined by incubating the macrophages in the presence of anti-CRBC antisera with [⁵¹Cr]-CRBC for one hour. Nonengulfed CRBC were lysed and removed before the macrophage-associated [⁵¹Cr]-CRBC were counted in a gamma counter (Gamma Trac 1191, T.M. Analytic). Alveolar macrophage generation of hydrogen peroxide in the presence and absence of lipopolysaccharide (LPS) was determined against standard hydrogen peroxide solutions by incubating cells overnight in RPMI-10 buffer with and without LPS. The samples were centrifuged and the supernatant from preparations containing LPS was removed for subsequent analysis of tumor necrosis factor production. The collected macrophages were incubated with a phenol red solution containing horseradish peroxidase. Color development was measured in an ELISA reader at 600 nm. Tumor necrosis factor production by alveolar macrophages was determined by bioassay with log-phase L-929 target cells in serum-free ultraculture medium (Whittaker) supplemented with actinomycin D (Sigma) and compared to standards prepared with recombinant tumor necrosis factor (Genzyme, Boston, MA). Supernatants from the hydrogen peroxide assays conducted with LPS were placed into 96-well plates with 4×10^4 L-929 cells per well and incubated for 24 hours; neutral red (Sigma) was added to each well for the final 4 hours of incubation. The L-929 cells were lysed with a mixture of ethanol and monobasic sodium phosphate, and absorbance was determined on a microplate reader at 550 nm (rats) or 540 nm (mice).

For mixed lymphocyte culture response and cytotoxic T cell response analyses, groups of eight female mice were sacrificed; the ability to recognize and respond to allogenic DBA/2 splenocytes in a mixed lymphocyte culture and show induction of cytotoxic T lymphocytes was monitored. For the splenocyte response assays, mice were sacrificed by cervical dislocation and sterile spleen cell suspensions were prepared. Splenocytes were suspended in RPMI-1640 medium with supplemented HEPES buffer, glutamine, gentamicin, penicillin, streptomycin, and heat-treated fetal bovine serum. Stimulator cells were prepared as irradiated splenocytes from 6-week-old DBA/2 male mice. Internal controls for this assay included cell suspensions cultured with

supplemented medium only to detect nonspecific stimulation and irradiated and nonirradiated DBA/2 stimulator cells cultured with concanavalin A. Each cell suspension was incubated with irradiated stimulator splenocytes and 0.5 μ M 2-mercaptoethanol for 96 hours at 37° C. Eighteen hours prior to incubation termination, [³H]-dT (1 μ Ci thymidine; specific activity 6.7 Ci/mmol) was added to the cell mixtures. Concanavalin A-treated culture did not contain 2-mercaptoethanol and was incubated for 72 hours. Radiolabel incorporation was determined by liquid scintillation spectrometry using a Tracor 6881 LS counter (Tracor Analytic, Elk Grove Village, IL). For induction of antigen-specific cytotoxic T lymphocytes, the erythrocytes were lysed with ammonium chloride/Tris and the lymphocyte suspension was washed with phosphate buffered saline. The cells were combined with P815 mastocytoma stimulator cells previously inactivated with mitomycin-C (Sigma) and allowed to incubate in Eagles minimal essential medium containing HEPES buffer, fetal bovine serum, glutamine, gentamicin, and 2-mercaptoethanol for 5 days at 37° C. The cells were washed, resuspended in media, combined with [⁵¹Cr]-P815 tumor target cells, and incubated at 37° C for 4 hours. Supernatants containing released radiolabel were harvested with a supernatant harvesting system (Skatron, Sterling, VA), and the radioactivity was quantitated using a gamma counter.

Necropsies were performed on all core study rats and mice. The heart, right kidney, liver, lung, right testis, and thymus of core study animals were weighed. Histopathologic examinations were performed on all organs from exposed animals that showed evidence of gross lesions along with corresponding organs of all chamber control animals. Table 2 lists the tissues and organs examined.

3-MONTH STUDIES

The 3-month studies were conducted to evaluate the cumulative toxic effects of repeated exposure to vanadium pentoxide and to determine the appropriate exposure concentrations to be used in the 2-year studies.

Male and female F344/N rats and B6C3F₁ mice were obtained from Taconic Farms, Inc. (Germantown, NY). On receipt, the rats and mice were 4 weeks old. Rats were quarantined for 12 or 13 days, and mice were quarantined for 10 or 14 days; animals were 6 or 7 weeks old on the first day of the studies. Before the studies began,

five male and five female rats and mice were randomly selected for parasite evaluation and gross observation for evidence of disease. At the end of the studies, serologic analyses were performed on five male and five female sentinel rats and mice using the protocols of the NTP Sentinel Animal Program (Appendix N).

Groups of 10 male and 10 female rats and mice were exposed to vanadium pentoxide at concentrations of 0, 1, 2, 4, 8, or 16 mg/m³, 6 hours plus T₉₀ (15 minutes) per day, 5 days per week for 3 months. Additional groups of 10 male and 10 female rats were exposed to the same concentrations for 12 (females) or 13 (males) weeks for clinical pathology and cardiopulmonary physiology analyses. Animals were removed from the exposure chambers for the cardiopulmonary physiology studies. Feed was available *ad libitum* except during exposure periods; water was available *ad libitum*. Feed was also withheld during urine collection, and water was withheld for the second urine collection. Rats and mice were housed individually. Clinical findings were recorded weekly. The animals were weighed initially, weekly, and at the end of the studies. Details of the study design and animal maintenance are summarized in Table 2.

Blood was collected for hematology and clinical chemistry determinations from cardiopulmonary physiology study rats on days 4 and 23 and from core study rats at study termination. At all time points, the rats were anesthetized with a 70% CO₂:30% air mixture, and blood was collected from the retroorbital sinus. Blood for hematology determinations was placed in tubes containing EDTA as the anticoagulant. Automated hematocrit; erythrocyte, reticulocyte, leukocyte and platelet counts; hemoglobin concentration; mean cell volume; mean cell hemoglobin; and mean cell hemoglobin concentration were determined using a Baker 9000 hematology analyzer (Serono-Baker Diagnostics, Inc., Allentown, PA). Manual hematocrit was determined following centrifugation using an IECMB microhematocrit centrifuge (International Equipment Co., Needham Heights, MA). Reticulocyte counts were determined by light microscopic examination of blood films stained with new methylene blue. Leukocyte differential counts were determined using light microscopic examination of blood films stained with Wright's stain. Blood for serum chemistry analyses was placed in tubes without anticoagulant, allowed to clot, and centrifuged to separate the serum. Serum chemistry parameters were determined using a Synchron CX5 automated analyzer (Beckman Instruments, Inc., Brea, CA) with reagents provided by the manufacturer, except those for sorbitol dehydro-

genase and bile acid determinations were provided by Sigma. The parameters measured are listed in Table 2.

Urine was collected from core study rats during weeks 12 (0, 4, 8, and 16 mg/m³ females) and 13 (0, 2, 4, and 8 mg/m³ males). Rats were placed in metabolism cages for 16 hours immediately following exposure. The urine collection containers were kept immersed in ice to suppress bacterial growth. Food was removed, but the rats had free access to water during the urine collection. Following the urine collection, the rats were returned to their respective exposure chambers. Two days after urine collections, urine concentrating ability studies were performed. For these studies, the rats were deprived of water for 16 hours. At the end of the deprivation period, the rats were placed in metabolism cages without access to feed or water, and the urine was collected for 4 hours.

At the end of the 3-month studies, samples were collected for sperm motility and vaginal cytology evaluations from core study rats and mice exposed to 0, 2 (male rats only), 4, 8, or 16 (female rats and male and female mice) mg/m³. The parameters evaluated are listed in Table 2. Methods used were those described in the NTP's sperm morphology and vaginal cytology evaluations protocol (NTP, 1987). For 12 consecutive days prior to scheduled terminal sacrifice, the vaginal vaults of the females were moistened with saline, if necessary, and samples of vaginal fluid and cells were stained. Relative numbers of leukocytes, nucleated epithelial cells, and large squamous epithelial cells were determined and used to ascertain estrous cycle stage (i.e., diestrus, proestrus, estrus, and metestrus). Male animals were evaluated for sperm count and motility. The left testis and left epididymis were isolated and weighed. The tail of the epididymis (cauda epididymis) was then removed from the epididymal body (corpus epididymis) and weighed. Test yolk (rats) or modified Tyrode's buffer (mice) was applied to slides and a small incision was made at the distal border of the cauda epididymis. The sperm effluxing from the incision were dispersed in the buffer on the slides, and the numbers of motile and nonmotile spermatozoa were counted for five fields per slide by two observers. Following completion of sperm motility estimates, each left cauda epididymis was placed in buffered saline solution. Caudae were finely minced, and the tissue was incubated in the saline solution and then heat fixed at 65° C. Sperm density was then determined microscopically with the aid of a hemacytometer. To quantify spermatogenesis, the testicular spermatid head count was determined by removing the

tunica albuginea and homogenizing the left testis in phosphate-buffered saline containing 10% dimethyl sulfoxide. Homogenization-resistant spermatid nuclei were counted with a hemacytometer.

For the cardiovascular analyses, rats were anesthetized intraperitoneally with sodium pentobarbital to facilitate implantation of electrodes for electrocardiogram measurements. Four electrodes were inserted subcutaneously on the dorsal surface of each limb and one was placed above the apex of the heart. Electrocardiogram analyses were performed using an Electronics for Medicine amplifier and oscilloscope camera. Upon completion of the pulmonary function tests described below, a cannula was inserted into the left carotid artery and flushed with heparinized saline. The catheter was connected to a Motorola pressure transducer (Motorola, Inc., Arlington Heights, IL) and an amplifier. Blood pressure wave forms were photographically recorded and systolic and diastolic pressure were obtained.

For the pulmonary function analyses, a cannula was transthoracically inserted into the trachea, and the rats were placed in a whole-body flow plethysmograph (BUXCO Electronics, Inc., Sharon, CT). An esophageal catheter was inserted. Chest wall excursions were detected using a pressure transducer (Validyne Engineering, Northridge, CA) connected to the plethysmograph. Airway opening pressure was sensed using Validyne pressure transducers; esophageal pressure was sensed using Motorola pressure transducers. After tidal breathing measurements were taken, the rats were removed from the plethysmograph and the esophageal catheter was withdrawn. Using a syringe attached to a pressure transducer, vital capacity was measured as the volume in the syringe required to inflate the animal from -15 to +30 cm water pressure. Total lung capacity was obtained by the gas dilution method using 0.5% neon (Takezawa *et al.*, 1980). Residual volume was computed as the total lung capacity minus the vital capacity. Multibreath diffusing capacity of carbon monoxide was obtained by gas dilution using 0.5% carbon monoxide. Rats were returned to the plethysmograph. Airway opening pressure and box pressure were measured. For pressure-volume measurements, the lungs were slowly inflated to total capacity and then allowed to relax passively. Vital capacity and compliance were measured. Small-airway integrity was evaluated during forced expiration. The lungs were inflated as described above. A solenoid opened rapidly to expose the rat's airway, and

forced expiration parameters were computed from the resultant maximum expiratory flow-volume curve.

For pulmonary lavage analyses, the rats were sacrificed by intraperitoneal injection of sodium pentobarbital and their lungs were lavaged *in situ*. Cells were collected from the lavage fluid by centrifugation. Fluid protein concentration and total, viable, and differentiated cell counts were determined by methods similar to those described for analyses of tracheobronchial lavage fluids in the 16-day studies.

Necropsies were performed on all core study animals. The heart, right kidney, liver, lung, right testis, and thymus were weighed. Tissues for microscopic examination were fixed and preserved in 10% neutral buffered formalin, processed and trimmed, embedded in paraffin, sectioned to a thickness of 4 to 6 μm , and stained with hematoxylin and eosin. A complete histopathologic examination was performed on 0, 8, and 16 mg/m^3 rats and 0 and 16 mg/m^3 mice. Table 2 lists the tissues and organs routinely examined.

16-DAY SPECIAL STUDIES

Tissue burden studies were conducted in female rats and mice to determine lung and blood vanadium concentrations and lung clearance half-times of vanadium in anticipation of measuring tissue burdens during the 2-year studies. Because histopathology of the lung was not performed in the 16-day studies, histopathology and cell proliferation analyses of the lung following short-term exposure were performed to assess the early lung effects with the intent to possibly conduct mechanistic studies independently or during the 2-year studies.

Female F344/N rats and B6C3F₁ mice were obtained from Taconic Farms, Inc. (Germantown, NY). On receipt, the rats and mice were 4 weeks old. Animals were quarantined for 13 days and were 6 weeks old on the first day of the studies.

Groups of 60 female rats and mice were exposed to vanadium pentoxide at concentrations of 0, 1 (rats only), 2, or 4 (mice only) mg/m^3 , groups of 40 female rats were exposed to 4 mg/m^3 , and groups of 40 female mice were exposed to 8 mg/m^3 , 6 hours plus T₉₀ (12 minutes) per day, 5 days per week for 16 days. Feed was available *ad libitum* except during exposure periods; water was available *ad libitum*. Rats and mice were housed

individually. Details of the study design and animal maintenance are summarized in Table 2.

For cell proliferation studies, 10 female rats and mice per group were implanted subcutaneously on study days -1 or 7 with osmotic minipumps (Model 2001, Alza Corp., Palo Alto, CA) prefilled with a 30 mg/mL solution of 5-bromo-2-deoxyuridine (BrdU; Sigma) in 0.01 N sodium hydroxide. The pumps were incubated in phosphate buffered saline at 37° C for approximately 4 hours and then implanted between 1300 and 1600 hours in animals anesthetized with xylazine and ketamine. After 6 days (140 ± 3 hours) of BrdU exposure, the animals were evaluated for tissue incorporation of BrdU on necropsy days 6 and 13. The lungs (with a section of duodenum as a positive control) and nasal turbinates were fixed in neutral formalin. Two slides per tissue were prepared from each animal. One slide was stained with hematoxylin and eosin and examined microscopically and a second slide was stained with BrdU antibody. Labeled cells were counted using a 40× objective, and tissue wall length measurements were made using the measuring features of the Optimas program (Bioscan, Inc., Edmonds, WA). Cell proliferation was measured as the number of labeled epithelial cell nuclei/mm of terminal bronchiole basement membrane or alveolar wall length.

For the special histopathologic evaluation, necropsies were performed on four randomly selected rats and mice from each group immediately following exposure on days 1, 2, 5, 10, and 16. The lungs, larynx, trachea, and nasal turbinates were fixed in modified Karnovsky's fixative. Hematoxylin and eosin-stained lung tissue was evaluated microscopically for vanadium pentoxide injury.

For tissue burden studies, five animals from each of the 0, 1 (rats only), 2, or 4 (mice only) mg/m³ groups were evaluated for the extent of distribution of vanadium in the lung and blood on postexposure days 0, 1, 4, and 8. Animals were anesthetized with sodium pentobarbital, and blood was obtained by cardiac puncture and divided between tubes containing EDTA and separate serum collection tubes. The lungs were removed and weighed. Lungs and blood were digested with concentrated nitric acid in a microwave. After the addition of an internal standard solution containing yttrium, vanadium was quantitated in the lung and blood digests using ICP/AES (Minitorch Model 3410, Applied Research Laboratories, Inc., Valencia, CA) and an autosampler (Model 222, Gilson Medical Electronics, Middleton, MI). Lung

clearance and area under the curve were calculated using a first-order clearance model; equations for these calculations are included in Appendix K.

2-YEAR STUDIES

Study Design

Groups of 50 male and 50 female core study rats and mice were exposed to particulate aerosols of vanadium pentoxide concentrations of 0, 0.5 (rats only), 1, 2, or 4 (mice only) mg/m³, 6 hours plus T₉₀ (12 minutes) per day, 5 days per week for 104 weeks. Additional groups of 40 female rats and 40 female mice per exposed group were designated for tissue burden analyses; separate control groups of 15 female rats and 15 female mice were used as chamber controls for the tissue burden studies.

Source and Specification of Animals

Male and female F344/N rats and B6C3F₁ mice were obtained from Taconic Farms, Inc. (Germantown, NY) for use in the 2-year studies. Animals were quarantined for 19 (rats) or 16 (mice) days before the beginning of the studies. Five male and five female rats and mice were randomly selected for parasite evaluation and gross observation of disease. Animals were 6 to 7 weeks old at the beginning of the studies. The health of the animals was monitored during the studies according to the protocols of the NTP Sentinel Animal Program (Appendix N).

Animal Maintenance

Rats and mice were housed individually. Feed was available *ad libitum* except during exposure periods; water was available *ad libitum*. Cages and racks were rotated weekly. Further details of animal maintenance are given in Table 2. Information on feed composition and contaminants is provided in Appendix M.

Tissue Burden Studies

Lungs and whole blood were collected from five female rats in each exposure group sacrificed on study day 1, 5, 12, 26, 54, 173, 360, or 542; the same tissues were collected from five mice in each exposure group sacrificed on day 1, 5, 12, 26, 54, 171, 362, or 535. Groups of five chamber control animals were bled at each of these time points and returned to their chambers and used for subsequent bleedings. Prior to tissue collection, exposed animals were anesthetized with sodium pentobarbital, and chamber control animals were anesthetized with

70% CO₂:30% air. Blood was obtained by cardiac puncture from exposed animals or from the retroorbital sinus of chamber control animals and placed in tubes containing EDTA. The lungs and associated tissues were removed from exposed animals; after the left and right lung were trimmed, separated, and weighed, the left lung was fixed in 10% neutral buffered formalin and stained with hematoxylin and eosin for histopathologic examination, and the right lung was digested to measure vanadium concentration. Vanadium concentrations in blood and right lung nitric acid digests were measured using ICP/AES and an autosampler as described for the 16-day special burden studies. Equations for calculations of lung deposition and clearance parameters using a first-order deposition and elimination model are included in Appendix K.

Clinical Examinations and Pathology

All animals were observed twice daily. Animals were weighed at the beginning of the studies. Clinical findings and body weights were recorded every 4 weeks from week 5 through 89 and every 2 weeks from week 92 to the end of the study.

Complete necropsies and microscopic examinations were performed on all core study rats and mice. At necropsy, all organs and tissues were examined for grossly visible lesions, and all major tissues were fixed and preserved in 10% neutral buffered formalin, processed and trimmed, embedded in paraffin, sectioned to a thickness of 4 to 6 µm, and stained with hematoxylin and eosin for microscopic examination. For all paired organs (e.g., adrenal gland, kidney, ovary), samples from each organ were examined. Tissues examined microscopically are listed in Table 2.

Microscopic evaluations were completed by the study laboratory pathologist, and the pathology data were entered into the Toxicology Data Management System. The slides, paraffin blocks, and residual wet tissues were sent to the NTP Archives for inventory, slide/block match, and wet tissue audit. The slides, individual

animal data records, and pathology tables were evaluated by an independent quality assessment laboratory. The individual animal records and tables were compared for accuracy, the slide and tissue counts were verified, and the histotechnique was evaluated. For the 2-year studies, a quality assessment pathologist evaluated slides from all tumors and all potential target organs, which included the larynx, lung, and nose of rats and mice and the uterus of female rats. Bronchial and mediastinal lymph nodes from all male and female rats were evaluated for pigment, and ovaries from all female rats were evaluated for cysts. Bronchial lymph nodes from all male and female mice were evaluated for hyperplasia, and uteri from female mice were evaluated for hydrometra and cystic hyperplasia.

The quality assessment report and the reviewed slides were submitted to the NTP Pathology Working Group (PWG) chairperson, who reviewed the selected tissues and addressed any inconsistencies in the diagnoses made by the laboratory and quality assessment pathologists. Representative histopathology slides containing examples of lesions related to chemical administration, examples of disagreements in diagnoses between the laboratory and quality assessment pathologists, or lesions of general interest were presented by the chairperson to the PWG for review. The PWG consisted of the quality assessment pathologist and other pathologists experienced in rodent toxicologic pathology. This group examined the tissues without any knowledge of dose groups or previously rendered diagnoses. When the PWG consensus differed from the opinion of the laboratory pathologist, the diagnosis was changed. Final diagnoses for reviewed lesions represent a consensus between the laboratory pathologist, reviewing pathologist(s), and the PWG. Details of these review procedures have been described, in part, by Maronpot and Boorman (1982) and Boorman *et al.* (1985). For subsequent analyses of the pathology data, the decision of whether to evaluate the diagnosed lesions for each tissue type separately or combined was generally based on the guidelines of McConnell *et al.* (1986).

TABLE 2
Experimental Design and Materials and Methods in the Inhalation Studies of Vanadium Pentoxide

16-Day Studies	3-Month Studies	16-Day Special Studies	2-Year Studies
Study Laboratories IITRI (Chicago, IL)	IITRI (Chicago, IL)	Battelle Toxicology Northwest (Richland, WA)	Battelle Toxicology Northwest (Richland, WA)
Strain and Species F344/N rats B6C3F ₁ mice	F344/N rats B6C3F ₁ mice	F344/N rats B6C3F ₁ mice	F344/N rats B6C3F ₁ mice
Animal Source Simonsen Laboratories (Gilroy, CA)	Taconic Farms, Inc. (Germantown, NY)	Taconic Farms, Inc. (Germantown, NY)	Taconic Farms, Inc. (Germantown, NY)
Time Held Before Studies Rats: 12 days Mice: 13 days (core study) or 12 days (immunotoxicology studies)	Rats: 13 days (males) or 12 days (females) Mice: 14 days (males) or 10 or 14 days (female)	13 days	Rats: 19 days Mice: 16 days
Average Age When Studies Began 6 weeks	6 to 7 weeks	6 weeks	6 to 7 weeks
Date of First Exposure Rats: April 10, 1990 Mice: April 11 (core study) or 10 (immunotoxicology studies), 1990	Rats: September 19 (males) or 18 (females), 1990 Mice: September 20, 1990	February 8, 1996	Rats: January 6, 1997 Mice: January 13, 1997
Duration of Exposure 6 hours plus T ₉₀ (15 minutes) per day, 5 days per week, for 16 days	6 hours plus T ₉₀ (15 minutes) per day, 5 days per week, for 91 days (rats and female mice) and 92 days (male mice)	6 hours plus T ₉₀ (12 minutes) per day, 5 days per week, for 16 days	6 hours plus T ₉₀ (12 minutes) per day, 5 days per week, for 104 weeks
Date of Last Exposure Rats: April 25, 1990 Mice: April 26 (core study) or 25 (immunotoxicology studies), 1990	Rats: December 18 (males) or 17 (females), 1990 Mice: December 20 (males) or 19 (females), 1990	February 23, 1996	Rats: December 31, 1998 Mice: January 8, 1999
Necropsy Dates Rats: April 26, 1990 Mice: April 27, 1990	Rats: December 19 (males) or 18 (females), 1990 Mice: December 21 (males) or 20 (females), 1990	February 8, 9, 12, 17, and 23, 1996	Rats: January 4-8, 1999 Mice: January 11-15, 1999
Average Age at Necropsy 9 weeks	19 to 20 weeks	6-8 weeks	111 weeks
Size of Study Groups Core studies: 5 males and 5 females Immunotoxicology studies: 22 male rats and 50 female mice	Core studies: 10 male and 10 female rats and mice Cardiopulmonary physiology studies: 10 male and 10 female rats	40 (4 mg/m ³ rats and 8 mg/m ³ mice) or 60 females	Core studies: 50 males and 50 females Tissue burden studies: 15 (chamber control) or 40 females

TABLE 2
Experimental Design and Materials and Methods in the Inhalation Studies of Vanadium Pentoxide

16-Day Studies	3-Month Studies	16-Day Special Studies	2-Year Studies
Method of Distribution Animals were distributed randomly into groups of approximately equal initial mean body weights.	Same as 16-day studies	Same as 16-day studies	Same as 16-day studies
Animals per Cage 1	1	1	1
Method of Animal Identification Tail tattoo	Tail tattoo	Tail tattoo	Tail tattoo
Diet NIH-07 open formula pelleted diet (Zeigler Brothers, Inc., Gardners, PA), available <i>ad libitum</i> except during exposure periods changed weekly	Same as 16-day studies, except food was not available during urine collection periods	NTP-2000 pelleted diet (Zeigler Brothers, Inc., Gardners, PA), available <i>ad libitum</i> except during exposure periods, changed weekly	Same as 16-day special studies except irradiated
Water Tap water (City of Chicago municipal supply) via automatic watering system (Edstrom Industries, Waterford, WI), available <i>ad libitum</i> , changed weekly	Same as 16-day studies, except water was not available during the second urine collection period	Same as 16-day studies, except Richland, WA, municipal supply water used	Same as 16-day studies, except Richland, WA, municipal supply water used
Cages Stainless steel wire mesh (Lab Products, Inc., Garfield, NJ), changed weekly	Stainless steel wire mesh (Lab Products, Inc., Maywood, NJ), changed weekly	Stainless steel wire bottom (Hazleton Systems, Inc., Aberdeen, MD), changed weekly	Same as 16-day special studies
Chamber Air Supply Filters HEPA (R&R Equipment Sales, Rosemont, IL)	Same as 16-day studies	Single HEPA (Northland Filter System International, Inc., Mechanicville, NY); charcoal (RSE, Inc., New Baltimore, MI); Purafil (Environmental Systems, Lynnwood, WA)	Same as 16-day special studies
Chambers Stainless steel (Lab Products, Inc., Garfield NJ), changed weekly	Stainless steel (Lab Products, Inc., Maywood NJ), changed weekly	Stainless steel (Lab Products, Inc., Harford Systems Division, Aberdeen, MD), changed weekly	Same as 16-day special studies
Chamber Environment Temperature: 75° ± 3° F Relative humidity: 55% ± 15% Room fluorescent light: 12 hours/day Chamber air changes: 15/hour	Temperature: 75° ± 3° F Relative humidity: 55% ± 15% Room fluorescent light: 12 hours/day Chamber air changes: 15/hour	Temperature: 75° ± 3° F Relative humidity: 55% ± 15% Room fluorescent light: 12 hours/day Chamber air changes: 15/hour	Temperature: 75° ± 3° F Relative humidity: 55% ± 15% Room fluorescent light: 12 hours/day Chamber air changes: 15/hour

TABLE 2
Experimental Design and Materials and Methods in the Inhalation Studies of Vanadium Pentoxide

16-Day Studies	3-Month Studies	16-Day Special Studies	2-Year Studies
Exposure Concentrations 0, 2, 4, 8, 16, or 32 mg/m ³	0, 1, 2, 4, 8, or 16 mg/m ³	Rats: 0, 1, 2, or 4 mg/m ³ Mice: 0, 2, 4, or 8 mg/m ³	Rats: 0, 0.5, 1, or 2 mg/m ³ Mice: 0, 1, 2, or 4 mg/m ³
Type and Frequency of Observation Observed twice daily; animals were weighed initially, on day 7 (core studies only), and at the end of the studies; clinical findings were recorded daily.	Observed twice daily; animals were weighed initially, weekly, and at the end of the studies; clinical findings were recorded weekly.	Observed twice daily; animals were weighed on day 1.	Observed twice daily, body weights were recorded on day 1 and clinical findings and body weights were recorded every 4 weeks from week 5 through 89 and every 2 weeks from week 92 until the end of the studies.
Method of Sacrifice CO ₂ asphyxiation	CO ₂ asphyxiation	CO ₂ asphyxiation	CO ₂ asphyxiation
Necropsy Necropsy was performed on all core study animals. Organs weighed were the heart, right kidney, liver, lung, right testis, and thymus.	Necropsy was performed on all core study animals. Organs weighed were the heart, right kidney, liver, lung, right testis, and thymus.	Necropsy was performed on four animals per group on days 1, 2, 5, 10, and 16.	Necropsy was performed on all core study animals.
Clinical Pathology None	Blood was collected from the retroorbital sinus of cardiopulmonary physiology study rats on days 4 and 23 and from core study rats at the end of the studies for hematology and clinical chemistry analyses. Male core study rats exposed to 0, 2, 4, or 8 mg/m ³ and female core study rats exposed to 0, 4, 8, or 16 mg/m ³ were placed in metabolism cages for urine collection during week 12 (females) or 13 (males). Hematology: automated hematocrit; manual hematocrit; hemoglobin concentration; erythrocyte, reticulocyte, nucleated erythrocyte, and platelet counts; erythrocyte morphology; mean cell volume; mean cell hemoglobin; mean cell hemoglobin concentration; leukocyte count and differentials Clinical chemistry: urea nitrogen, creatinine, total protein, albumin, alanine aminotransferase, alkaline phosphatase, creatine kinase, sorbitol dehydrogenase, bile acids Urinalysis: volume, specific gravity Urine concentrating ability: volume, specific gravity	None	None

TABLE 2
Experimental Design and Materials and Methods in the Inhalation Studies of Vanadium Pentoxide

16-Day Studies	3-Month Studies	16-Day Special Studies	2-Year Studies
<p>Histopathology Histopathology was performed on all organs from exposed animals that showed evidence of gross lesions along with the corresponding organs of all chamber control animals.</p>	<p>Complete histopathology was performed on 0, 8 (rats only), and 16 mg/m³ rats and mice. In addition to gross lesions and tissue masses, the following tissues were examined: adrenal gland, bone with marrow, brain, clitoral gland, esophagus, gallbladder (mice only), heart and aorta, large intestine (cecum, colon, and rectum), small intestine (duodenum, jejunum, and ileum), kidney, larynx, liver, lung and mainstem bronchi, lymph nodes (mandibular, mediastinal, mesenteric, and bronchial), mammary gland, nose, ovary, pancreas, parathyroid gland, pituitary gland, preputial gland, prostate gland, salivary gland, skin, spleen, stomach (forestomach and glandular), testis (with epididymis and seminal vesicle), thymus, thyroid gland, trachea, urinary bladder, and uterus. The lung of rats and mice and nose of rats in all remaining exposure groups and the thymus in 8 mg/m³ mice were also examined.</p>	<p>Histopathology was performed on lung tissue from four animals in each exposure group on days 1, 2, 5, 10, and 16.</p>	<p>Complete histopathology was performed on all core study animals. In addition to gross lesions and tissue masses, the following tissues were examined: adrenal gland, bone with marrow, brain, clitoral gland, esophagus, gallbladder (mice only), heart and aorta, large intestine (cecum, colon, and rectum), small intestine (duodenum, jejunum, and ileum), kidney, larynx, liver, lung and mainstem bronchi, lymph nodes (mandibular, mediastinal, mesenteric, and bronchial), mammary gland (except male mice), nose, ovary, pancreas, parathyroid gland, pituitary gland, preputial gland, prostate gland, salivary gland, skin, spleen, stomach (forestomach and glandular), testis (with epididymis and seminal vesicle), thymus, thyroid gland, trachea, urinary bladder, and uterus.</p>
<p>Sperm Motility and Vaginal Cytology None</p>	<p>At the end of the studies, sperm samples were collected from core study male rats in the 0, 2, 4, and 8 mg/m³ groups and male mice in the 0, 4, 8, and 16 mg/m³ groups for sperm motility evaluations. The following parameters were evaluated: spermatid heads per testis and per gram testis, spermatid counts, and epididymal spermatozoal motility and concentration. The left cauda, left epididymis, and left testis were weighed. Vaginal samples were collected for up to 12 consecutive days prior to the end of the studies from core study female rats and mice exposed to 0, 4, 8, or 16 mg/m³ for vaginal cytology evaluations. The percentage of time spent in the various estrous cycle stages and estrous cycle length were evaluated.</p>	<p>None</p>	<p>None</p>

TABLE 2
Experimental Design and Materials and Methods in the Inhalation Studies of Vanadium Pentoxide

16-Day Studies	3-Month Studies	16-Day Special Studies	2-Year Studies
<p>Special Studies</p> <p>Immunotoxicology Studies: Immunotoxicology studies were performed on day 16 for groups of rats and/or mice exposed to 0, 4, 8, or 16 mg/m³</p> <p>Influenza virus challenge: Groups of 20 female mice were instilled intranasally with influenza virus and evaluated for morbidity for 14 days.</p> <p>Pulmonary bactericidal activity analyses: Lungs from groups of 12 male rats and 12 female mice exposed to viable radiolabeled [³⁵S]-<i>K. pneumoniae</i> were evaluated for pulmonary bactericidal activity 3 hours after inoculation.</p> <p>Pulmonary lavage analyses: Alveolar fluid from 10 male rats and 10 female mice was collected by tracheobronchial lavage for measurement of protein concentration and lysozyme activity. Total, viable, and differentiated lavage cell counts were performed. Alveolar macrophages were evaluated for hydrogen peroxide and tumor necrosis factor production and Fc receptor-mediated phagocytosis (male rats only).</p> <p>Mixed lymphocyte culture response/cytotoxic T cell response analyses: Groups of eight female mice were evaluated for mixed lymphocyte response to allogenic splenocytes and induction of cytotoxic T lymphocytes.</p>	<p>Cardiopulmonary Physiology Studies: Cardiopulmonary physiology studies were performed during week 12 (female) or 13 (male) for groups of 10 male and 10 female rats exposed to 0, 4, 8, or 16 mg/m³</p> <p>Cardiovascular analyses: heart rate; systolic, diastolic, and mean blood pressure; PR, QRS, and QT intervals; axis shift</p> <p>Pulmonary function analyses:</p> <p><i>Tidal breathing measurements:</i> respiratory rate; tidal and minute volume; esophageal pressure; inspiratory and expiratory time; peak inspiratory and peak expiratory flow; expiratory resistance; dynamic compliance</p> <p><i>Lung volume diffusion capacity and pressure-volume relationships:</i> vital and total lung capacity; end expiratory and residual volume; diffusion capacity of carbon monoxide; chord slope, and peak compliance</p> <p><i>Forced expiration measurements:</i> forced vital capacity; forced expiratory volume at 50, 100, 200, and 400 mseconds; peak expiratory flow; volume at peak expiratory flow; mean mid-expiratory flow; flow at 75%, 50%, 25%, and 10% of forced vital capacity</p> <p>Pulmonary lavage analyses: total, viable, and differential cell counts; protein concentration</p>	<p>Cell Proliferation Studies: On days 6 and 13, the lungs of 10 rats and mice per group were evaluated for cell proliferation by measuring the incorporation of BrdU implanted 140 ± 3 hours earlier and were reviewed histopathologically.</p> <p>Tissue Burden Studies: Lung and blood from groups of five animals exposed to 0, 1 (rats only), 2, or 4 (mice only) mg/m³ were evaluated on postexposure days 0, 1, 4, and 8. Lung weight, lung burden, and blood vanadium concentration were measured.</p>	<p>Tissue Burden Studies: Groups of five female rats were evaluated on days 1, 5, 12, 26, 54, 173, 360, and 542; groups of five female mice were evaluated on days 1, 5, 12, 26, 54, 171, 362, and 535. Total lung weight, right lung burden, and left lung histopathology were measured in exposed animals at all time points. Blood vanadium concentration was measured in all animals at all time points after day 12.</p>

STATISTICAL METHODS

Survival Analyses

The probability of survival was estimated by the product-limit procedure of Kaplan and Meier (1958) and is presented in the form of graphs. Animals found dead of other than natural causes were censored from the survival analyses; animals dying from natural causes were not censored. Statistical analyses for possible dose-related effects on survival used Cox's (1972) method for testing two groups for equality and Tarone's (1975) life table test to identify dose-related trends. All reported P values for the survival analyses are two sided.

Calculation of Incidence

The incidences of neoplasms or nonneoplastic lesions are presented in Tables A1, A5, B1, B5, C1, C5, D1, and D5 as the numbers of animals bearing such lesions at a specific anatomic site and the numbers of animals with that site examined microscopically. For calculation of statistical significance, the incidences of most neoplasms (Tables A3, B3, C3, and D3) and all nonneoplastic lesions are given as the numbers of animals affected at each site examined microscopically. However, when macroscopic examination was required to detect neoplasms in certain tissues (e.g., hardy gland, intestine, mammary gland, and skin) before microscopic evaluation, or when neoplasms had multiple potential sites of occurrence (e.g., leukemia or lymphoma), the denominators consist of the number of animals on which a necropsy was performed. Tables A3, B3, C3, and D3 also give the survival-adjusted neoplasm rate for each group and each site-specific neoplasm. This survival-adjusted rate (based on the Poly-3 method described below) accounts for differential mortality by assigning a reduced risk of neoplasm, proportional to the third power of the fraction of time on study, to animals that do not reach terminal sacrifice.

Analysis of Neoplasm and Nonneoplastic Lesion Incidences

The Poly-k test (Bailer and Portier, 1988; Portier and Bailer, 1989; Piegorsch and Bailer, 1997) was used to assess neoplasm and nonneoplastic lesion prevalence. This test is a survival-adjusted quantal-response procedure that modifies the Cochran-Armitage linear trend test to take survival differences into account. More specifically, this method modifies the denominator in the quantal estimate of lesion incidence to approximate more closely the total number of animal years at risk.

For analysis of a given site, each animal is assigned a risk weight. This value is one if the animal had a lesion at that site or if it survived until terminal sacrifice; if the animal died prior to terminal sacrifice and did not have a lesion at that site, its risk weight is the fraction of the entire study time that it survived, raised to the kth power.

This method yields a lesion prevalence rate that depends only upon the choice of a shape parameter for a Weibull hazard function describing cumulative lesion incidence over time (Bailer and Portier, 1988). Unless otherwise specified, a value of $k=3$ was used in the analysis of site-specific lesions. This value was recommended by Bailer and Portier (1988) following an evaluation of neoplasm onset time distributions for a variety of site-specific neoplasms in control F344 rats and B6C3F₁ mice (Portier *et al.*, 1986). Bailer and Portier (1988) showed that the Poly-3 test gave valid results if the true value of k was anywhere in the range from 1 to 5. A further advantage of the Poly-3 method is that it does not require lesion lethality assumptions. Variation introduced by the use of risk weights, which reflect differential mortality, was accommodated by adjusting the variance of the Poly-3 statistic as recommended by Bieler and Williams (1993).

Tests of significance included pairwise comparisons of each exposed group with controls and a test for an overall exposure-related trend. Continuity-corrected Poly-3 tests were used in the analysis of lesion incidence, and reported P values are one sided. The significance of lower incidences or decreasing trends in lesions is represented as 1-P with the letter N added (e.g., $P=0.99$ is represented as $P=0.01N$).

Analysis of Continuous Variables

Two approaches were employed to assess the significance of pairwise comparisons between exposed and control groups in the analysis of continuous variables. Organ and body weight data, which historically have approximately normal distributions, were analyzed with the parametric multiple comparison procedures of Dunnett (1955) and Williams (1971, 1972). Hematology, clinical chemistry, urinalysis, urine concentrating ability, cardiopulmonary, immunotoxicologic, cell proliferation, tissue concentrations, spermatid, and epididymal spermatozoal data, which have typically skewed distributions, were analyzed using the nonparametric multiple comparison methods of Shirley (1977) and Dunn (1964). Jonckheere's test (Jonckheere, 1954) was used to assess the significance of the dose-related trends and to determine whether a trend-sensitive test

(Williams' or Shirley's test) was more appropriate for pairwise comparisons than a test that does not assume a monotonic dose-related trend (Dunnett's or Dunn's test). Prior to statistical analysis, extreme values identified by the outlier test of Dixon and Massey (1951) were examined by NTP personnel, and implausible values were eliminated from the analysis. Average severity values were analyzed for significance with the Mann-Whitney U test (Hollander and Wolfe, 1973). Because vaginal cytology data are proportions (the proportion of the observation period that an animal was in a given estrous stage), an arcsine transformation was used to bring the data into closer conformance with a normality assumption. Treatment effects were investigated by applying a multivariate analysis of variance (Morrison, 1976) to the transformed data to test for simultaneous equality of measurements across exposure concentrations.

Historical Control Data

The concurrent control group represents the most valid comparison to the treated groups and is the only control group analyzed statistically in NTP bioassays. However, historical control data are often helpful in interpreting potential treatment-related effects, particularly for uncommon or rare neoplasm types. For meaningful comparisons, the conditions for studies in the historical database must be generally similar. Until recently, the NTP historical control database consisted of animals fed NIH-07 diet. In 1995, the NTP changed the diet fed to animals used in toxicity and carcinogenesis studies conducted by the NTP. This new diet (NTP-2000) contains less protein and more fiber and fat than the NIH-07 diet previously used (Rao, 1996, 1997). This dietary change was instituted primarily to increase longevity and decrease the incidence and/or severity of some spontaneous neoplastic and nonneoplastic lesions in the rats and mice used in NTP studies. These studies of vanadium pentoxide are among the first in which the animals on study were fed the NTP-2000 diet. Because the incidence of some neoplastic and nonneoplastic lesions may be affected by the dietary change, use of the existing historical control database (NIH-07 diet) may not be appropriate for all neoplasm types.

The concurrent database includes 11 (10 for male rats) studies by various routes in which the NTP-2000 diet was used. Based on the extensive NTP historical database using the NIH-07 diet, incidences of the vast majority of spontaneous neoplasms are not significantly different between control groups regardless of the route

of administration. There is no reason to expect this to change using the NTP-2000 diet. For example, control animals from dosed feed and dosed water studies are treated no differently and no differences in incidence of neoplasms are expected. Exceptions exist for some neoplasms/routes, and if comparisons are necessary for these neoplasm types, only studies with similar routes of administration will be used.

QUALITY ASSURANCE METHODS

The 3-month and 2-year studies were conducted in compliance with Food and Drug Administration Good Laboratory Practice Regulations (21 CFR, Part 58). In addition, as records from the 2-year studies were submitted to the NTP Archives, these studies were audited retrospectively by an independent quality assurance contractor. Separate audits covered completeness and accuracy of the pathology data, pathology specimens, final pathology tables, and a draft of this NTP Technical Report. Audit procedures and findings are presented in the reports and are on file at NIEHS. The audit findings were reviewed and assessed by NTP staff, and all comments were resolved or otherwise addressed during the preparation of this Technical Report.

GENETIC TOXICOLOGY

The genetic toxicity of vanadium pentoxide was assessed by testing the ability of the chemical to induce mutations in various strains of *Salmonella typhimurium* and increases in the frequency of micronucleated erythrocytes in mouse peripheral blood. The protocols for these studies and the results are given in Appendix E.

The genetic toxicity studies have evolved from an earlier effort by the NTP to develop a comprehensive database permitting a critical anticipation of a chemical's carcinogenicity in experimental animals based on numerous considerations, including the molecular structure of the chemical and its observed effects in short-term *in vitro* and *in vivo* genetic toxicity tests (structure-activity relationships). The short-term tests were originally developed to clarify proposed mechanisms of chemical-induced DNA damage based on the relationship between electrophilicity and mutagenicity (Miller and Miller, 1977) and the somatic mutation theory of cancer (Straus, 1981; Crawford, 1985). However, it should be noted that not all cancers arise through genotoxic mechanisms.

DNA reactivity combined with *Salmonella* mutagenicity is highly correlated with induction of carcinogenicity in multiple species/sexes of rodents and at multiple tissue sites (Ashby and Tennant, 1991). A positive response in the *Salmonella* test was shown to be the most predictive *in vitro* indicator for rodent carcinogenicity (89% of the *Salmonella* mutagens are rodent carcinogens) (Tennant *et al.*, 1987; Zeiger *et al.*, 1990). Additionally, no battery of tests that included the *Salmonella* test improved the predictivity of the *Salmonella* test alone. However, these other tests can provide useful information on the types of DNA and chromosomal damage induced by the chemical under investigation.

The predictivity for carcinogenicity of a positive response in acute *in vivo* bone marrow chromosome aberration or micronucleus tests appears to be less than

that in the *Salmonella* test (Shelby *et al.*, 1993; Shelby and Witt, 1995). However, clearly positive results in long-term peripheral blood micronucleus tests have high predictivity for rodent carcinogenicity (Witt *et al.*, 2000); negative results in this assay do not correlate well with either negative or positive results in rodent carcinogenicity studies. Because of the theoretical and observed associations between induced genetic damage and adverse effects in somatic and germ cells, the determination of *in vivo* genetic effects is important to the overall understanding of the risks associated with exposure to a particular chemical. Most organic chemicals that are identified by the International Agency for Research on Cancer as human carcinogens, other than hormones, are genotoxic. The vast majority of these are detected by both the *Salmonella* assay and rodent bone marrow cytogenetics tests (Shelby, 1988; Shelby and Zeiger, 1990).

RESULTS

RATS

16-DAY STUDY

Three males exposed to 32 mg/m³ died before the end of the study (Table 3). Final mean body weights and body weight gains of males and females exposed to 8 mg/m³ or greater were less than those of the chamber controls. During the first week of the study, red nasal discharge, rapid respiration, and hypoactivity were observed in all 32 mg/m³ rats; rapid respiration was also observed in all rats exposed to 16 mg/m³. Rapid, shallow respiration

was most visible during exposure periods but persisted immediately following exposure. From day 8 until the end of the study, rats in the 32 mg/m³ groups became emaciated and had hunched and/or abnormal posture and a rough coat; one of the two surviving males had labored breathing. Urine staining, salivation, and diarrhea were observed in 32 mg/m³ females. Ocular or nasal discharge was noted in the 16 mg/m³ groups.

Relative lung weights of 4 mg/m³ or greater males and 2 mg/m³ or greater females were significantly greater

TABLE 3
Survival and Body Weights of Rats in the 16-Day Inhalation Study of Vanadium Pentoxide

Concentration (mg/m ³)	Survival ^a	Mean Body Weight ^b (g)			Final Weight Relative to Controls (%)
		Initial	Final	Change	
Male					
0	5/5	123 ± 4	212 ± 7	89 ± 5	
2	5/5	124 ± 6	211 ± 6	87 ± 3	99
4	5/5	126 ± 5	209 ± 7	83 ± 4	99
8	5/5	122 ± 4	194 ± 6	73 ± 3*	92
16	5/5	125 ± 4	184 ± 7**	59 ± 5**	87
32	2/5 ^c	125 ± 6	128 ± 15**	4 ± 9**	60
Female					
0	5/5	104 ± 3	142 ± 2	38 ± 2	
2	5/5	103 ± 3	141 ± 3	38 ± 2	100
4	5/5	102 ± 2	137 ± 1	35 ± 2	97
8	5/5	101 ± 3	131 ± 3*	30 ± 1*	92
16	5/5	102 ± 4	125 ± 5**	23 ± 2**	88
32	5/5	102 ± 4	106 ± 5**	4 ± 4**	75

* Significantly different (P ≤ 0.05) from the chamber control group by Williams' test

** P ≤ 0.01

^a Number of animals surviving at 16 days/number initially in group

^b Weights and weight changes are given as mean ± standard error. Subsequent calculations are based on animals surviving to the end of the study.

^c Day of death: 6

than those of the chamber controls (Table H1). Other organ weight differences were considered to be related to body weight decreases.

Gross lesions observed at necropsy were not considered to be exposure related. Complete histopathology was not performed.

A localized inflammatory response in the lung was evident in male rats based on increases in cell number, protein, neutrophils, and lysozymes in lavage fluid in all exposed groups. There was also a significant decrease in macrophages in lavage fluids of male rats exposed to

8 or 16 mg/m³. There were no effects on systemic immunity, evidenced by a normal response to *Klebsiella pneumoniae*. Other measures of immune function were not considered to be significantly different than those of the chamber controls (Appendix J).

Exposure Concentration Selection Rationale: Based on decreased survival in the 32 mg/m³ males and body weight decreases in 32 mg/m³ males and females, an exposure concentration of 32 mg/m³ was considered too high for use in a 3-month study. Therefore, the exposure concentrations selected for the 3-month inhalation study in rats were 0, 1, 2, 4, 8, and 16 mg/m³.

3-MONTH STUDY

Seven males and three females exposed to 16 mg/m³ died during the study (Table 4). Final mean body weights and body weight gains of males exposed to 4 mg/m³ or greater and of females exposed to 16 mg/m³ were significantly less than those of the chamber controls. Abnormal breathing, thinness, lethargy, abnormal posture, and ruffled fur were observed in rats exposed to 16 mg/m³. Abnormal breathing, marked by shallow, rapid respiration, was first observed during and immediately following exposure periods; this was observed in

all 16 mg/m³ rats by week 2 and in all 8 mg/m³ rats by week 4. By week 9, the abnormal breathing was also observed in 16 mg/m³ rats during nonexposure periods. Some rats in the 16 mg/m³ groups had diarrhea and nasal/eye discharge. Abnormal posture was observed in two males exposed to 8 mg/m³, and one of these rats was thin with ruffled fur and nasal/eye discharge.

The hematology, clinical chemistry, urinalysis, and urine concentrating ability data for rats are presented in Table G1, and selected hematology data are presented in

TABLE 4
Survival and Body Weights of Rats in the 3-Month Inhalation Study of Vanadium Pentoxide

Concentration (mg/m ³)	Survival ^a	Mean Body Weight ^b (g)			Final Weight Relative to Controls (%)
		Initial	Final	Change	
Male					
0	10/10	133 ± 3	330 ± 7	197 ± 6	
1	10/10	136 ± 4	338 ± 5	202 ± 5	102
2	10/10	136 ± 5	316 ± 5	180 ± 5	96
4	10/10	137 ± 4	310 ± 7*	173 ± 8**	94
8	10/10	135 ± 5	296 ± 7**	161 ± 5**	90
16	3/10 ^c	133 ± 4	131 ± 7**	1 ± 9**	40
Female					
0	10/10	108 ± 3	194 ± 3	87 ± 3	
1	10/10	111 ± 3	199 ± 5	88 ± 4	102
2	10/10	108 ± 2	205 ± 5	96 ± 4	105
4	10/10	110 ± 2	192 ± 4	83 ± 3	99
8	10/10	108 ± 2	185 ± 5	77 ± 4	95
16	7/10 ^d	109 ± 2	136 ± 5**	25 ± 7**	70

* Significantly different ($P \leq 0.05$) from the chamber control group by Williams' test

** $P \leq 0.01$

^a Number of animals surviving at 3 months/number initially in group

^b Weights and weight changes are given as mean ± standard error. Subsequent calculations are based on animals surviving to the end of the study.

^c Week of death: 8, 8, 8, 9, 11, 11, 11

^d Week of death: 9, 12, 13

Table 5. The hematology results indicated that exposure of rats to vanadium pentoxide affected the circulating red cell mass. On day 4, there were minimal decreases in the erythron as demonstrated by decreases in the hematocrit values and hemoglobin concentrations in 8 and 16 mg/m³ males and in 2 mg/m³ or greater females. In general, the erythrocyte counts reflected similar and proportional, but not significant, decreases. On day 23, the minimal erythron decreases were evident in males exposed to 4 mg/m³ or greater but had ameliorated in the females. Erythrocyte counts on day 23 were unaffected in exposed males but were minimally increased in 16 mg/m³ females. While this lack of an erythrocyte count decrease would seem incongruous, there were exposure concentration-related decreases in the mean cell volumes and mean cell hemoglobin values on day 23, which are consistent with a developing erythrocyte microcytosis. The mean cell volumes and/or mean cell hemoglobin values were decreased in 2 mg/m³ or greater males and 4 mg/m³ or greater females, suggesting that the circulating erythrocytes were smaller than expected. Additionally, the mean cell hemoglobin concentration was minimally decreased in 16 mg/m³ females. Erythrocyte microcytosis has been observed in several NTP studies involving exposure to metals by inhalation (NTP, 1996a,b, 1998, 2000, 2001), drinking water (NTP, 1994), or feed (NTP, 1993a). Erythrocyte microcytosis would be consistent with an ineffective erythropoiesis, suggesting altered iron metabolism and a subsequent alteration in heme/hemoglobin production (Jain, 1986). As a consequence of the smaller erythrocytes, hematocrit values and hemoglobin concentrations can indicate decreases in the erythron even though erythrocyte counts are unchanged or are greater than chamber control values. At week 13, the erythron decrease had disappeared and was replaced by an erythrocytosis, evidenced by substantial increases in hematocrit values, hemoglobin concentrations, and erythrocyte counts in 16 mg/m³ males and females. Erythrocyte counts were also minimally increased in 8 mg/m³ males and females. The erythrocytosis was accompanied by increased reticulocyte and/or nucleated erythrocyte counts, suggesting that an increased production of erythrocytes contributed to the erythrocytosis. The erythrocytosis would be consistent with the pulmonary lesions that resulted in altered oxygen transfer by the lungs and subsequent tissue hypoxia and stimulation of erythropoiesis by increased production of erythropoietin by the kidneys (Jain, 1986). Minimal to mild decreases in mean cell volumes and/or mean cell hemoglobin values persisted in 2 mg/m³ or greater males and in 4 mg/m³ or greater females, and mean cell hemoglobin concentra-

tions were decreased in 16 mg/m³ males and females. Microscopic evaluation of the red blood cell morphology detected increased polychromasia, anisochromia, and hypochromia in the 16 mg/m³ groups (data not presented); these findings would be consistent with the increased reticulocyte counts and decreased mean cell hemoglobin concentrations.

On days 4 and 23, 2 mg/m³ or greater females had minimal increases in leukocyte counts, which appeared to be related to increased numbers of segmented neutrophils and lymphocytes. Because there was no exposure-concentration relationship or consistency between males and females, the transient increase in leukocyte counts in exposed females on days 4 and 23 were not considered toxicologically relevant. At week 13, however, there was evidence of an exposure-related leukopenia, demonstrated by decreases in leukocyte counts in 16 mg/m³ males and females. The leukopenia appeared to be related to decreased lymphocyte counts. This alteration in lymphocyte counts suggests a physiological response and would be consistent with a stress-related corticosteroid-induced lymphopenia. Rats are considered a steroid-sensitive species and corticosteroid-induced lymphopenia may be related to lympholysis in blood and altered distribution (Jain, 1986). The 16 mg/m³ males and females demonstrated microscopic evidence of lymphoid depletion in numerous lymphoid organs. Since there was an exceptional effect on body weights of 16 mg/m³ rats, it is possible that these animals were under significant stress that then lead to increased endogenous corticosteroid concentrations and subsequent decreases in tissue and blood lymphocytes.

Altered clinical chemistry variables occurred in exposed males and females. At all time points, evidence of a hepatocellular effect was demonstrated by increases in serum alanine aminotransferase activities in 8 and 16 mg/m³ males and females. However, sorbitol dehydrogenase activities, another marker of hepatocellular injury or leakage, were not affected, and there were no histopathologic liver changes consistent with hepatocellular injury. This suggests that the increased alanine aminotransferase activities were not related to hepatocellular injury. Studies have shown that corticosteroids can induce increases in liver alanine aminotransferase activities (Rosen, 1959; Rosen *et al.*, 1959). Thus, stress-related corticosteroid-induced increases in liver alanine aminotransferase activities may, in part, help explain increased serum alanine aminotransferase activities. At all time points, there were generally exposure concentration-related decreases in serum alkaline

TABLE 5
Selected Hematology Data for Rats in the 3-Month Inhalation Study of Vanadium Pentoxide^a

	Chamber Control	1 mg/m ³	2 mg/m ³	4 mg/m ³	8 mg/m ³	16 mg/m ³
Male						
Hematology						
n						
Day 4	10	10	10	10	10	9
Day 23	9	10	8	10	10	10
Week 13	9	9	10	9	10	3
Automated hematocrit (%)						
Day 4	48.3 ± 1.4	48.6 ± 0.8	50.1 ± 1.3	47.7 ± 1.0	46.1 ± 0.7	45.8 ± 0.5
Day 23	49.7 ± 1.0	48.5 ± 0.6	47.9 ± 0.6	46.7 ± 0.5**	46.9 ± 0.7*	46.5 ± 0.9**
Week 13	48.5 ± 0.6	47.7 ± 0.5	47.6 ± 0.6	48.7 ± 0.9	49.9 ± 0.7	71.2 ± 2.8*
Manual hematocrit (%)						
Day 4	50.2 ± 1.3	50.6 ± 0.8	51.3 ± 1.4	49.3 ± 1.1	47.3 ± 0.7*	46.0 ± 0.6**
Day 23	51.7 ± 1.2	51.0 ± 0.6	50.4 ± 0.6	49.0 ± 0.7	50.1 ± 0.6	48.0 ± 0.8**
Week 13	49.3 ± 0.5	48.8 ± 0.4	48.7 ± 0.5	50.1 ± 0.5	50.9 ± 0.7	67.7 ± 1.9**
Hemoglobin (g/dL)						
Day 4	15.5 ± 0.4	15.8 ± 0.3	16.1 ± 0.5	15.4 ± 0.3	14.8 ± 0.2	14.6 ± 0.1*
Day 23	16.3 ± 0.3	16.0 ± 0.1	15.7 ± 0.2	15.3 ± 0.2**	15.5 ± 0.2**	15.0 ± 0.3**
Week 13	15.8 ± 0.1	15.5 ± 0.1	15.5 ± 0.2	15.9 ± 0.2	16.1 ± 0.2	20.4 ± 0.8
Erythrocytes (10 ⁶ /μL)						
Day 4	7.92 ± 0.20	7.93 ± 0.11	8.29 ± 0.22	7.79 ± 0.17	7.51 ± 0.10*	7.54 ± 0.10
Day 23	8.48 ± 0.17	8.31 ± 0.12	8.31 ± 0.12	8.11 ± 0.10	8.28 ± 0.12	8.52 ± 0.17
Week 13	9.17 ± 0.10	9.02 ± 0.09	9.10 ± 0.09	9.32 ± 0.18	9.73 ± 0.12*	15.21 ± 0.28**
Reticulocytes (10 ⁶ /μL)						
Day 4	0.31 ± 0.02	0.35 ± 0.03	0.36 ± 0.04	0.33 ± 0.03 ^b	0.34 ± 0.02	0.35 ± 0.02
Day 23	0.23 ± 0.02	0.20 ± 0.01	0.21 ± 0.02	0.21 ± 0.02	0.21 ± 0.02	0.24 ± 0.01
Week 13	0.20 ± 0.02	0.22 ± 0.03	0.19 ± 0.02	0.23 ± 0.03	0.25 ± 0.02	0.86 ± 0.08*
Nucleated erythrocytes/100 leukocytes						
Day 4	1.90 ± 0.50	0.80 ± 0.25	1.40 ± 0.40	1.30 ± 0.42	0.80 ± 0.25	0.78 ± 0.22
Day 23	0.44 ± 0.18	0.70 ± 0.15	0.13 ± 0.13	0.30 ± 0.21	0.20 ± 0.13	0.90 ± 0.18
Week 13	0.56 ± 0.24	1.22 ± 0.32	0.40 ± 0.16	1.33 ± 0.33	1.40 ± 0.22*	174.67 ± 41.57**
Mean cell volume (fL)						
Day 4	60.9 ± 0.4	61.3 ± 0.5	60.4 ± 0.4	61.3 ± 0.4	61.5 ± 0.4	60.7 ± 0.3
Day 23	58.6 ± 0.2	58.3 ± 0.2	57.7 ± 0.3*	57.5 ± 0.3*	56.7 ± 0.3**	54.6 ± 0.3**
Week 13	52.9 ± 0.2	52.9 ± 0.1	52.3 ± 0.1*	52.2 ± 0.2*	51.3 ± 0.2**	46.8 ± 1.0**
Mean cell hemoglobin (pg)						
Day 4	19.6 ± 0.1	20.0 ± 0.2	19.4 ± 0.2	19.7 ± 0.1	19.7 ± 0.2	19.3 ± 0.1
Day 23	19.3 ± 0.2	19.3 ± 0.1	18.9 ± 0.1	18.9 ± 0.1	18.7 ± 0.1	17.6 ± 0.2**
Week 13	17.3 ± 0.2	17.2 ± 0.1	17.1 ± 0.1	17.1 ± 0.2	16.5 ± 0.2**	13.4 ± 0.4**
Mean cell hemoglobin concentration (g/dL)						
Day 4	32.2 ± 0.2	32.6 ± 0.2	32.1 ± 0.2	32.2 ± 0.1	32.1 ± 0.2	31.8 ± 0.2
Day 23	32.9 ± 0.3	33.0 ± 0.2	32.7 ± 0.1	32.8 ± 0.2	33.0 ± 0.2	32.2 ± 0.2
Week 13	32.6 ± 0.3	32.5 ± 0.2	32.6 ± 0.2	32.7 ± 0.4	32.2 ± 0.3	28.7 ± 0.8*

TABLE 5
Selected Hematology Data for Rats in the 3-Month Inhalation Study of Vanadium Pentoxide

	Chamber Control	1 mg/m ³	2 mg/m ³	4 mg/m ³	8 mg/m ³	16 mg/m ³
Female						
Hematology						
n						
Day 4	10	8	10	10	10	10
Day 23	9	10	9	9	10	10
Week 13	10	10	9	10	10	6
Automated hematocrit (%)						
Day 4	48.6 ± 1.3	48.9 ± 1.0	45.0 ± 0.6	46.8 ± 1.7	44.6 ± 0.5*	45.5 ± 0.7
Day 23	47.3 ± 0.4	47.9 ± 0.4	47.6 ± 0.5	47.3 ± 0.4	47.1 ± 0.4	46.9 ± 0.6
Week 13	45.8 ± 0.5	44.3 ± 0.4	46.1 ± 1.2	46.4 ± 0.4	47.2 ± 0.6	60.8 ± 1.4**
Manual hematocrit (%)						
Day 4	50.4 ± 1.2	50.9 ± 0.8	46.2 ± 0.7**	48.1 ± 1.2*	46.0 ± 0.4**	46.0 ± 0.5**
Day 23	48.4 ± 0.5	48.5 ± 0.4	48.9 ± 0.4	48.8 ± 0.5	48.5 ± 0.5	48.4 ± 0.4
Week 13	47.8 ± 0.5	46.6 ± 0.4	48.7 ± 0.6	48.4 ± 0.2	49.4 ± 0.7	58.8 ± 1.3**
Hemoglobin (g/dL)						
Day 4	16.0 ± 0.3	16.3 ± 0.3	14.9 ± 0.2**	15.3 ± 0.5*	14.8 ± 0.2**	14.8 ± 0.2**
Day 23	15.8 ± 0.1	15.9 ± 0.1	15.8 ± 0.1	15.5 ± 0.2	15.5 ± 0.1*	15.1 ± 0.2**
Week 13	15.5 ± 0.2	15.0 ± 0.1	15.5 ± 0.2	15.6 ± 0.1	15.8 ± 0.1	18.2 ± 0.3**
Erythrocytes (10 ⁶ /μL)						
Day 4	8.05 ± 0.21	8.02 ± 0.16	7.43 ± 0.12	7.68 ± 0.28	7.38 ± 0.10	7.54 ± 0.15
Day 23	7.94 ± 0.06	8.00 ± 0.07	8.04 ± 0.09	7.96 ± 0.10	8.13 ± 0.09	8.51 ± 0.14**
Week 13	8.05 ± 0.08	7.78 ± 0.09	8.15 ± 0.20	8.33 ± 0.07	8.58 ± 0.12*	12.50 ± 0.36**
Reticulocytes (10 ⁶ /μL)						
Day 4	0.24 ± 0.03	0.26 ± 0.02	0.20 ± 0.01	0.27 ± 0.04	0.20 ± 0.01	0.26 ± 0.02
Day 23	0.14 ± 0.01	0.15 ± 0.01	0.14 ± 0.01	0.16 ± 0.01	0.19 ± 0.01	0.17 ± 0.02
Week 13	0.15 ± 0.02	0.17 ± 0.01	0.17 ± 0.01	0.16 ± 0.02	0.17 ± 0.02	0.45 ± 0.08**
Nucleated erythrocytes/100 leukocytes						
Day 4	0.90 ± 0.28	1.13 ± 0.44	1.80 ± 0.49	1.70 ± 0.56	0.60 ± 0.31	1.10 ± 0.35
Day 23	0.44 ± 0.34	0.40 ± 0.22 ^b	0.33 ± 0.17	0.33 ± 0.17	0.50 ± 0.17	0.40 ± 0.16
Week 13	1.70 ± 0.42	1.67 ± 0.33 ^b	1.56 ± 0.63	1.30 ± 0.30	1.10 ± 0.41	58.50 ± 26.41**
Mean cell volume (fL)						
Day 4	60.3 ± 0.2	60.9 ± 0.2	60.6 ± 0.2	61.0 ± 0.3	60.5 ± 0.4	60.4 ± 0.3
Day 23	59.6 ± 0.2	60.0 ± 0.2	59.2 ± 0.2	59.4 ± 0.3	57.9 ± 0.3**	55.2 ± 0.3**
Week 13	56.9 ± 0.1	56.9 ± 0.1	56.6 ± 0.1	55.8 ± 0.1**	55.0 ± 0.2**	48.7 ± 0.6**
Mean cell hemoglobin (pg)						
Day 4	19.9 ± 0.2	20.3 ± 0.1	20.1 ± 0.3	19.9 ± 0.1	20.1 ± 0.1	19.7 ± 0.2
Day 23	19.9 ± 0.1	19.9 ± 0.1	19.7 ± 0.2	19.5 ± 0.1*	19.1 ± 0.1**	17.8 ± 0.2**
Week 13	19.3 ± 0.2	19.3 ± 0.2	19.0 ± 0.2	18.7 ± 0.2*	18.5 ± 0.2**	14.6 ± 0.3**
Mean cell hemoglobin concentration (g/dL)						
Day 4	33.0 ± 0.3	33.4 ± 0.2	33.1 ± 0.4	32.6 ± 0.3	33.3 ± 0.3	32.6 ± 0.3
Day 23	33.4 ± 0.3	33.2 ± 0.2	33.2 ± 0.2	32.9 ± 0.1	33.0 ± 0.1	32.3 ± 0.3**
Week 13	33.9 ± 0.4	33.9 ± 0.3	33.6 ± 0.4	33.6 ± 0.3	33.6 ± 0.4	30.1 ± 0.3**

* Significantly different ($P \leq 0.05$) from the chamber control group by Dunn's or Shirley's test

** $P \leq 0.01$

^a Mean ± standard error. Statistical tests were performed on unrounded data.

^b n=9

phosphatase activities and total protein and albumin concentrations in males and females. At week 13, urea nitrogen concentrations were increased in 16 mg/m³ males and females, suggesting a possible effect on renal clearance. However, creatinine concentrations, another marker of renal clearance, were minimally decreased on day 23 in 8 mg/m³ males and at week 13 in 16 mg/m³ males and females; these decreases would be consistent with the decreased body weights observed in these groups. Since alkaline phosphatase activity and total protein, albumin, and urea nitrogen concentrations can be affected by altered nutritional status, the changes in these variables may have been related secondarily to body weight decreases and altered food intake. Significant increases and decreases in bile acid concentrations and creatine kinase activities in various exposure groups at various time points were not considered to be toxicologically relevant.

After 12 (females) or 13 (males) weeks of exposure, the baseline (water-replete) overnight urine collection demonstrated decreased urine volumes and increased urine specific gravities in the 8 mg/m³ male and 16 mg/m³ female groups, suggesting these animals were able to concentrate their urine; the 16 mg/m³ male group was not tested. These findings also suggest that these exposure groups may have been in a partially dehydrated state prior to the water deprivation studies. The 4-hour urine collection following a 16-hour water deprivation period demonstrated no differences in urine volume or specific gravity. This suggests that animals in all exposed groups maintained their ability to concentrate urine. For baseline and water deprivation test samples, microscopic evaluation of the urine demonstrated slight increases in formed elements in 8 mg/m³ males (baseline: casts, epithelial cells, erythrocytes, and leukocytes; water-deprived: casts) and 16 mg/m³ females (baseline and water deprived: leukocytes) (data not presented). While changes in formed urine elements can be indicative of various renal effects, the alterations in this study were not excessive and possibly reflected the hydration status of the animals; they were not considered to be toxicologically relevant.

Absolute and relative lung weights of 4 mg/m³ or greater males and females were significantly greater than those of the chamber controls; in addition, the relative lung weights of 2 mg/m³ males were significantly greater than those of the chamber controls (Table H2). Other organ

weight differences were considered to be related to body weight decreases.

Vanadium pentoxide exposure did not affect reproductive endpoints in males, but it did increase estrous cycle length in females exposed to 8 mg/m³ and reduced the number of cycling females in the 16 mg/m³ group (Tables I1 and I2).

The carcasses of males and females exposed to 16 mg/m³ were very thin, and the spleens and thymuses appeared disproportionately small. Lungs of 4 mg/m³ or greater males and 8 and 16 mg/m³ females varied from red to pale or mottled.

There were significant increases in the incidences of epithelial hyperplasia of the lung in males and females exposed to 2 mg/m³ or greater (Table 6). The incidences of inflammation or fibrosis were significantly increased in males exposed to 2 mg/m³ or greater and females exposed to 4 mg/m³ or greater. The epithelial hyperplasia occurred in the distal airways and associated alveolar ducts and alveoli. This change was qualitatively similar to the change observed in the 16-day special study and 2-year study; however, two diagnoses (alveolar epithelium hyperplasia and bronchiole epithelium hyperplasia) were used. In the distal airways, the epithelium was composed of ciliated cuboidal to columnar cells crowded together in multiple layers, sometimes forming folds and small papillary projections. More distal and including the alveolar ducts and alveoli, the epithelium tended to be a single layer. The epithelial cells were larger and rounded and appeared morphologically similar to bronchioles; this change has been termed "bronchiolization" in some studies. Goblet cells sometimes occurred within the epithelium of some of the smaller airways. Alveoli often contained one or two cells that were very large and occasionally binucleate. In one female exposed to 16 mg/m³, a single focus of squamous metaplasia was observed within an area of hyperplasia. Exudate of the bronchiole was diagnosed in many males and females exposed to 8 or 16 mg/m³ and was characterized by a mucoid material with admixed inflammatory cells within the lumens of some of the hyperplastic airways. The inflammation was characterized by accumulations of alveolar macrophages with abundant foamy cytoplasm in the alveoli adjacent to airways lined by hyperplastic epithelium. Mononuclear cells were also observed within the interstitium. In the 16-day special study, two

TABLE 6
Incidences of Selected Nonneoplastic Lesions of the Lung and Nose in Rats
in the 3-Month Inhalation Study of Vanadium Pentoxide

	Chamber Control	1 mg/m ³	2 mg/m ³	4 mg/m ³	8 mg/m ³	16 mg/m ³
Male						
Lung ^a	10	10	10	10	10	10
Epithelium, Hyperplasia ^b	0	0	10** (2.0) ^c	10** (3.0)	10** (3.6)	10** (3.3)
Inflammation	0	0	9** (1.0)	10** (1.0)	10** (1.6)	10** (2.1)
Fibrosis	0	0	2 (1.0)	10** (1.9)	10** (3.2)	10** (3.1)
Bronchiole, Exudate	0	0	0	0	7** (1.0)	8** (1.4)
Nose	10	10	10	10	10	10
Respiratory Epithelium, Hyperplasia	0	0	0	1 (1.0)	10** (1.2)	10** (2.0)
Respiratory Epithelium, Metaplasia, Squamous	0	0	0	1 (1.0)	10** (1.2)	10** (1.8)
Inflammation	0	0	0	0	0	7** (1.6)
Female						
Lung	10	10	10	10	10	10
Epithelium, Hyperplasia	0	0	10** (1.3)	10** (2.9)	10** (3.5)	10** (3.2)
Inflammation	0	0	0	10** (1.0)	10** (1.9)	10** (1.2)
Fibrosis	0	0	0	10** (1.0)	10** (2.9)	10** (3.2)
Bronchiole, Exudate	0	0	0	0	10** (1.0)	8** (1.1)
Nose	10	10	10	10	10	10
Respiratory Epithelium, Hyperplasia	0	0	0	10** (1.0)	10** (1.8)	10** (2.7)
Respiratory Epithelium, Metaplasia, Squamous	0	0	0	8** (1.0)	10** (1.8)	10** (2.8)
Inflammation	0	0	0	0	1 (1.0)	9** (1.6)

**Significantly different ($P \leq 0.01$) from the chamber control group by the Fisher exact test

^a Number of animals with tissue examined microscopically

^b Number of animals with lesion

^c Average severity grade of lesions in affected animals: 1=minimal, 2=mild, 3=moderate, 4=marked

diagnoses (histiocytic infiltrate and inflammation) were used for this change. Foci of fibrosis were found in the same areas and sometimes extended into surrounding alveoli. These foci were irregularly shaped and consisted of loosely arranged, delicate collagen fibers, fibroblasts, and mononuclear cells.

The incidences of hyperplasia and metaplasia of the nasal respiratory epithelium were significantly increased in males exposed to 8 or 16 mg/m³ and in females exposed to 4 mg/m³ or greater (Table 6). There were significantly increased incidences of inflammation of the

nose in males and females exposed to 16 mg/m³. The hyperplasia and metaplasia involved the respiratory epithelium covering the ventral portion of the nasal septum, the vomeronasal organ, and, to a lesser extent, the ventral lateral walls of the anterior portion of the nasal cavity. There were cellular crowding and epithelium thickening (hyperplasia) in some areas with loss of goblet cells and one or more layers of flattened nonkeratinizing squamous epithelium (metaplasia) in others. Inflammation was characterized by an infiltrate primarily of lymphocytes and lesser numbers of neutrophils within the affected mucosa and subjacent submucosa.

Occasionally, neutrophils predominated, and an exudate was present.

Depletion of lymphocytes in the spleen, thymus, and lymph nodes, atrophy of metaphyseal bone of the femur, and atrophy of the secondary reproductive organs were observed in 16 mg/m³ males and females and hypospermia of the testis and atypical cells of the epididymis were observed in 16 mg/m³ males. These lesions may have been associated with the marked body weight loss and general debilitation of these rats.

Cardiopulmonary Physiology Studies

Decreases in heart rate and in diastolic, systolic, and mean blood pressure were observed in male and female rats exposed to 16 mg/m³. It is unlikely that this response was the result of a direct cardiotoxic action of vanadium pentoxide, rather, it was considered to be a reflection of the poor condition of the animals coupled with an effect from anesthesia (Table F4).

Significant exposure-related changes in pulmonary function were observed in male and female rats exposed to 4, 8, or 16 mg/m³ (Tables 7, F1, F2, and F3). Only slight differences were observed between males and females, and the differences were not considered to be biologically significant. These results indicate that a more restrictive lesion was present in groups exposed to 4 mg/m³ or greater, evidenced by reduced lung compliance, changes in breathing measurements, impaired capacity to diffuse carbon monoxide, reduced static and dynamic lung volumes, and exaggerated flows. Exposure concentration-related decreases in chord, peak, and dynamic compliance were consistent with reduced lung elasticity. There was also an increase in respiratory rate and a decrease in tidal volume; these alterations are known to increase breathing efficiency in response to a restrictive disease. This breathing pattern preferentially ventilates airway dead space and results in increased minute volume to maintain adequate blood gas. Also characteristic of restrictive disease were reduced carbon monoxide diffusing capacity, which signifies obstructed airways and changes in membrane composition (thickened interstitium). The decrease in static lung volume (total lung capacity and vital capacity) and exaggerated flows, as described by flow volume curves corrected for lung volume, also were suggestive of restrictive disease (Figure 1).

Pulmonary function changes indicate an obstructive disease in the 16 mg/m³ groups, evidenced by changes in breathing mechanics, static lung volumes, and forced expiratory maneuvers. Expiratory resistance, an indicator of bronchoconstriction, and end expiratory and residual volume were increased, while dynamic lung volume was decreased. These changes suggest closure of distal airways due to extensive pathology, resulting in air being trapped in the alveoli and reduced flow during forced expiratory maneuvers. Lung pathology in rats exposed to 16 mg/m³ was not drastically different than that observed in rats exposed to 8 mg/m³. Thus, it is not clear whether pulmonary function results indicate an obstructive disease or merely reflect the deteriorating condition of the 16 mg/m³ rats.

Together, the pulmonary function changes indicate that a restrictive disease was present in male and female rats exposed to 4 mg/m³ or greater, while an obstructive lung disease may have been present only in the 16 mg/m³ groups.

The pulmonary lavage data indicate an inflammatory response in the lungs of exposed rats (Table F5). In general, there were no differences between males and females. Exposure concentration-related increases were observed in the total numbers of cells, lymphocytes, neutrophils, and protein recovered in pulmonary lavage fluid from rats exposed to vanadium pentoxide at concentrations up to 8 mg/m³. The percentages of macrophages in lavage fluid were similar between exposed and chamber control rats. However, in female rats exposed to 8 mg/m³ there was a decrease in the numbers of macrophages with concomitant increases in the numbers of neutrophils and lymphocytes. These endpoints also were affected in the 16 mg/m³ group, but to a lesser extent, which is most likely due to the overt toxicity of vanadium pentoxide evidenced by decreased body weights and severe bronchoconstriction and airway obstruction.

Exposure Concentration Selection Rationale: Based on the incidences and severities of respiratory lesions and increased lung weights in male and female rats, concentrations of 4 mg/m³ or greater were considered to be too high for use in a 2-year study. The exposure concentrations selected for the 2-year inhalation study in rats were 0.5, 1, and 2 mg/m³.

TABLE 7
Cardiopulmonary Physiology Data for Rats in the 3-Month Inhalation Study of Vanadium Pentoxide^a

	Chamber Control	4 mg/m ³	8 mg/m ³	16 mg/m ³
Male				
n	7	10	10	5
Respiratory rate (breaths/minute)	102.2 ± 18.7	171.5 ± 42.7**	188.3 ± 47.9**	120.5 ± 24.4 ^b
Tidal volume (mL)	1.73 ± 0.22	1.26 ± 0.17**	1.14 ± 0.18**	1.24 ± 0.15*
Minute volume (mL/minute)	175.3 ± 17.8	211.7 ± 32.9*	215.1 ± 34.0*	140.7 ± 21.5 ^b
Expiratory resistance (cm H ₂ O/mL/second)	0.12 ± 0.05 ^c	0.17 ± 0.08	0.15 ± 0.08	0.30 ± 0.12**
Dynamic compliance (mL/cm H ₂ O)	0.40 ± 0.14	0.23 ± 0.10**	0.15 ± 0.04**	0.11 ± 0.02**
Total lung capacity (mL)	12.8 ± 0.9 ^d	9.8 ± 0.8**	7.1 ± 0.7**	8.3 ± 1.6**
Residual volume (mL)	1.71 ± 0.22 ^d	1.69 ± 0.41	1.79 ± 0.55	3.09 ± 0.71**
Diffusing capacity of CO (mL/minute/mm Hg)	0.189 ± 0.012 ^d	0.138 ± 0.012**	0.088 ± 0.015**	0.078 ± 0.015**
Vital capacity (mL)	10.4 ± 0.6	7.7 ± 0.3**	4.9 ± 0.4**	5.2 ± 1.0**
Peak compliance (mL/cm H ₂ O)	1.07 ± 0.07	0.81 ± 0.11**	0.40 ± 0.05**	0.32 ± 0.06**
Compliance at 0 to 10 cm H ₂ O (mL/cm H ₂ O)	0.67 ± 0.04	0.42 ± 0.05**	0.24 ± 0.01**	0.23 ± 0.04**
End expiratory volume (mL)	4.5 ± 1.0	5.4 ± 0.4*	4.9 ± 0.5	8.6 ± 1.6**
Female				
n	9	9	9	6
Respiratory rate (breaths/minute)	74.6 ± 11.3	123.2 ± 18.3**	152.2 ± 32.3**	137.0 ± 38.6**
Tidal volume (mL)	1.50 ± 0.14	1.01 ± 0.20**	0.84 ± 0.09**	1.03 ± 0.11**
Minute volume (mL/minute)	111.9 ± 17.9	127.7 ± 23.4	128.8 ± 23.4	141.7 ± 42.0
Expiratory resistance (cm H ₂ O/mL/second)	0.10 ± 0.06	0.13 ± 0.05 ^d	0.11 ± 0.03	0.33 ± 0.13**
Dynamic compliance (mL/cm H ₂ O)	0.31 ± 0.07	0.21 ± 0.05** ^d	0.15 ± 0.04**	0.12 ± 0.04**
Total lung capacity (mL)	8.9 ± 1.0	7.8 ± 0.5**	5.6 ± 0.6** ^e	8.7 ± 1.0
Residual volume (mL)	1.09 ± 0.08	1.20 ± 0.24	1.05 ± 0.36 ^e	3.43 ± 0.69**
Diffusing capacity of CO (mL/minute/mm Hg)	0.115 ± 0.010	0.098 ± 0.010**	0.060 ± 0.004** ^e	0.081 ± 0.021**
Vital capacity (mL)	7.7 ± 1.1	6.3 ± 0.6**	4.4 ± 0.5**	5.0 ± 0.4** ^f
Peak compliance (mL/cm H ₂ O)	0.80 ± 0.12	0.65 ± 0.06**	0.36 ± 0.04**	0.35 ± 0.04** ^f
Compliance at 0 to 10 cm H ₂ O (mL/cm H ₂ O)	0.51 ± 0.07 ^d	0.38 ± 0.03** ^d	0.24 ± 0.02** ^d	0.22 ± 0.04** ^f
End expiratory volume (mL)	4.3 ± 0.8 ^d	3.9 ± 0.5 ^d	4.0 ± 0.5 ^g	8.6 ± 1.2** ^f

* Significantly different ($P \leq 0.05$) from the chamber control group by Dunnett's test

** $P \leq 0.01$

^a Data are presented as mean ± standard deviation.

^b n=4

^c n=6

^d n=8

^e n=10

^f n=5

^g n=7

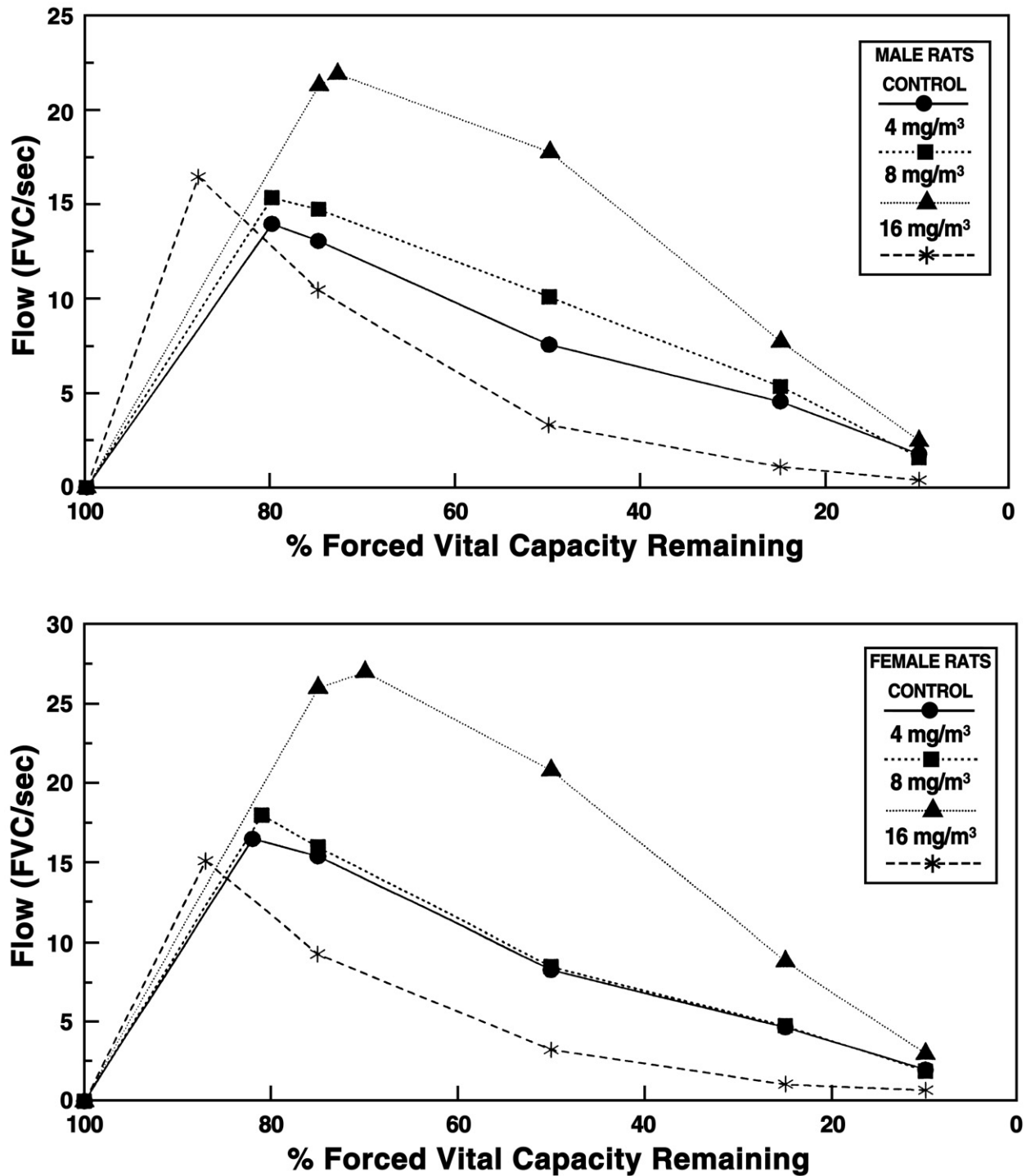

FIGURE 1
Flow Volume Curves For Male and Female Rats in the 3-Month Inhalation Study of Vanadium Pentoxide

The maximum expiratory flow, when normalized for differences in forced vital capacity, was increased at all percentages of the remaining forced vital capacity in rats with stiff lungs (males, 4 and 8 mg/m³; females, 8 mg/m³) while reduced in rats with obstructed lungs (16 mg/m³). The plotted points represent the flow parameters PEXF, F75%, F50%, F25%, and F10% divided by FVC plotted versus the %FVC remaining that defines each flow parameter. For the PEXF-derived point, %FVC remaining = $\frac{(FVC - VPEXF)}{FVC} \cdot 100$.

FVC

16-DAY SPECIAL STUDY

The 16-day special study was conducted to determine blood and lung concentrations of vanadium, the lung clearance half-time of vanadium, and the onset and extent of vanadium pentoxide-induced lung injury. Female rats were exposed to 0, 1, or 2 mg/m³ vanadium pentoxide for 14 days, and concentrations of vanadium in whole blood and lung tissue were determined. Elimination of vanadium from these tissues for a period up to 8 days after exposure was also determined. Cell proliferation rates were determined for lung tissue taken from 10 animals per group on days 6 and 13; microscopic examination of lung tissue was conducted for an additional 10 animals per group at each of these time points. In addition, the onset and extent of lung lesions in 0, 1, 2, or 4 mg/m³ females were evaluated in lung tissue collected from four rats per group on days 1, 2, 5, 10, and 16.

Tissue burden analyses and lung and blood vanadium concentration analyses were performed on female rats immediately following exposure on day 16 and on post-exposure days 1, 4, and 8. Lung weights of exposed rats were significantly greater than those of the chamber controls; there was little difference in lung weights among the exposed groups (Table K1). The lung weights of exposed rats remained greater than those of the chamber controls through day 4 of recovery but were similar to those of the chamber controls on day 8. Lung burdens were proportional to exposure concentration throughout the recovery period. The areas under the lung burden curves suggest proportionality between exposure concentration and lung burden (Table K2). This proportionality is more obvious when the area under the lung burden curves are normalized to exposure concentration (Figure 2). The observation that the normalized data are similar indicates linear toxicokinetics; that is, kinetic processes such as uptake, absorption, and clearance are not saturated in the exposure concentrations used in this study. Calculated lung clearance half-times during the 8-day recovery period were not significantly different among exposure groups (4.42 to 4.96 days) (Table K2).

Vanadium was detected in blood at concentrations several orders of magnitude less than those observed in lung tissue from exposed rats (Table K3). Blood vanadium concentrations in exposed and chamber control rats were for the most part highly variable and occurred at concentrations slightly above the limit of quantitation. The marginal increases in blood vanadium concentrations in

exposed rats indicate that either very little vanadium was absorbed or it was eliminated rapidly from the blood. There was little difference in blood vanadium concentrations among exposed groups. Although blood vanadium concentrations in exposed rats declined slightly on days 4 and 8, due to the variability, there may have been little or no difference in blood concentrations at each time point.

The following is a description of the pathology changes observed in the 10 animals examined on days 6 and 13. To allow identification of exposure-concentration and/or time-related increases in lesion severity, the grade of mild was used; however, the pulmonary changes observed in these animals were minimal. Hyperplasia of the alveolar and bronchiolar epithelium was observed in almost every rat exposed to 2 or 4 mg/m³ for 6 or 13 days, and alveolar epithelial hyperplasia was observed in 3 of 10 animals exposed to 1 mg/m³ for 13 days (Table 8). Increased numbers of alveolar macrophages (histiocytic infiltrate) were observed in virtually all exposed rats. Although slightly more pronounced in the rat, hyperplasia and histiocytic infiltration were similar to those in mice in the 16-day special study. Minimal to mild interstitial inflammation was observed in all rats exposed to 2 or 4 mg/m³ for 6 or 13 days, and in 3 of 10 and 8 of 10 rats exposed to 1 mg/m³ for 6 or 13 days, respectively. On day 6, this change was characterized by small numbers of mononuclear cells localized primarily around blood vessels. On day 13, it also involved small airways and sometimes extended into septae of alveolar ducts. Minimal to mild interstitial fibrosis also occurred in 6 of 10 animals exposed to 4 mg/m³ for 13 days.

The lungs from four rats exposed to vanadium pentoxide for 1, 2, 5, 10 or 16 days were evaluated histologically (data not presented). Lungs from rats exposed for 1 day revealed no significant differences between chamber control and exposed groups. Inflammation and histiocytic infiltrates were first observed on day 2 in rats exposed to 4 mg/m³, and hyperplasia of the alveolar and bronchiolar epithelium was first observed on day 5 in rats exposed to 2 or 4 mg/m³. While fibrosis occurred in 6 of 10 rats exposed to 4 mg/m³ for 13 days, fibrosis was observed in only one of four rats exposed to 4 mg/m³ for 10 days and in one of four rats exposed for 16 days. It was not clear if this slight inconsistency represented a true difference or reflected the subtle nature of this change by light microscopy.

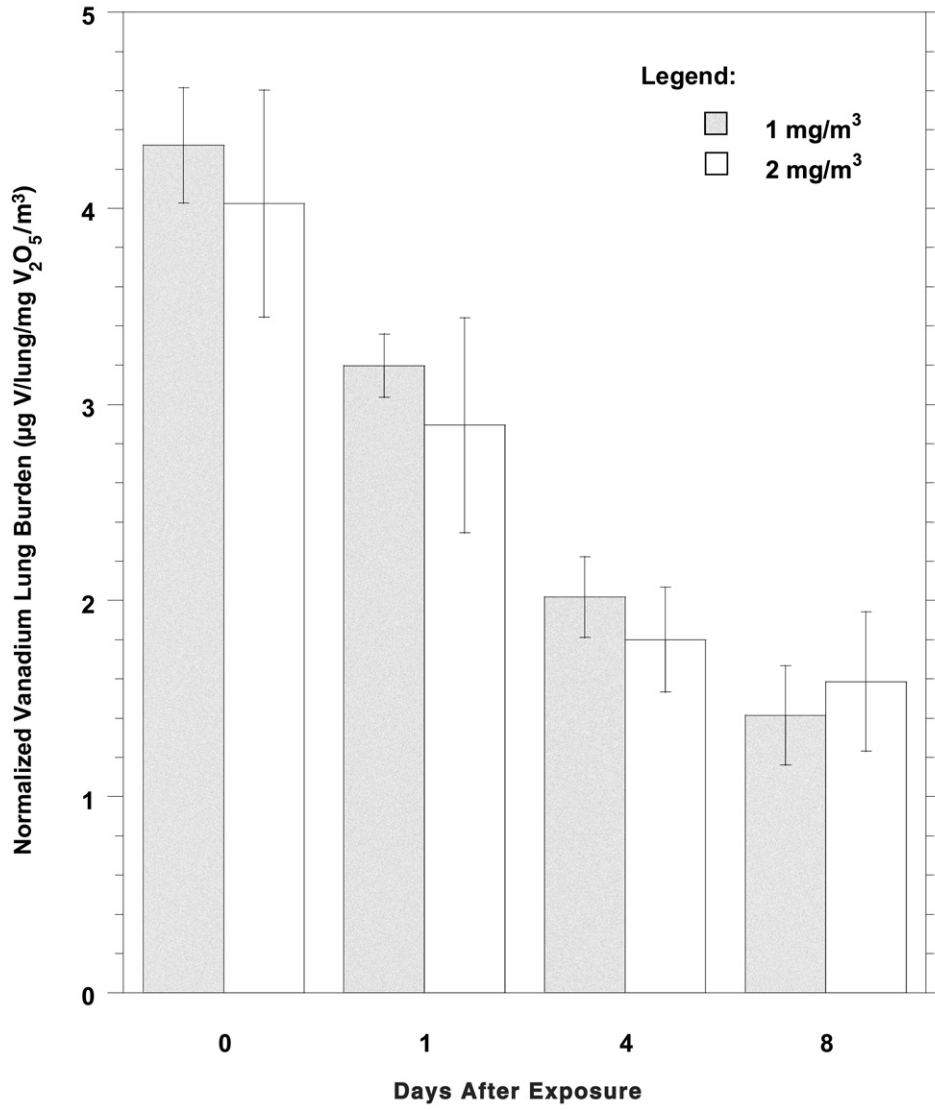

FIGURE 2
Normalized Lung Burden of Vanadium ($\mu\text{g V/Lung per mg V}_2\text{O}_5/\text{m}^3$)
in Female Rats Following 16 Days of Exposure to Vanadium Pentoxide.
 Data are presented as mean \pm standard deviation.

Cell turnover rates in the terminal bronchioles increased with increasing exposure concentration on days 6 and 13 (Table 9). Rates on day 13 were similar to those observed on day 6. In contrast, the incidence of alveolar

cell proliferation in only the 4 mg/m³ group was greater than that in the chamber control group on day 6. By day 13, rates were increased in all groups of exposed rats but not in an exposure concentration-related manner.

TABLE 8
Incidences of Nonneoplastic Lesions of the Lung in Female Rats in the 16-Day Special Study of Vanadium Pentoxide

	Chamber Control	1 mg/m ³	2 mg/m ³	4 mg/m ³
Day 6				
Number Examined Microscopically	10	10	10	10
Alveolar Epithelium, Hyperplasia ^a	0	0	10** (1.1) ^b	8** (1.4)
Bronchiole Epithelium, Hyperplasia	1 (1.0)	0	10** (1.7)	10** (1.8)
Histiocytic Infiltrate	2 (1.0)	6 (1.3)	10** (1.4)	10** (1.8)
Inflammation	0	3 (1.0)	10** (1.5)	10** (2.5)
Day 13				
Number Examined Microscopically	10	10	10	10
Alveolar Epithelium, Hyperplasia	0	3 (1.0)	10** (1.0)	10** (2.0)
Bronchiole Epithelium, Hyperplasia	0	0	10** (1.0)	10** (1.8)
Histiocytic Infiltrate	0	10** (1.3)	10** (1.9)	10** (2.2)
Inflammation	0	8** (1.3)	10** (1.7)	10** (2.0)
Fibrosis	0	0	0	6** (1.5)

** Significantly different ($P \leq 0.01$) from the chamber control group by the Fisher exact test

^a Number of animals with lesion

^b Average severity grade of lesions in affected animals: 1=minimal, 2=mild, 3=moderate, 4=marked

TABLE 9
Bromodeoxyuridine-Labeled Lung Nuclei in Female Rats in the 16-Day Special Study of Vanadium Pentoxide^a

	Chamber Control	1 mg/m ³	2 mg/m ³	4 mg/m ³
n	10	10	10	10
Terminal Bronchiole				
Day 6	21.88 ± 1.43	33.58 ± 1.77	56.08 ± 3.36	83.08 ± 5.56
Day 13	24.24 ± 1.12	45.91 ± 2.04	62.72 ± 3.03	91.96 ± 4.65
Alveoli/Alveolar Duct Areas				
Day 6	0.75 ± 0.03	0.54 ± 0.03	0.76 ± 0.05	1.68 ± 0.12
Day 13	0.83 ± 0.03	1.82 ± 0.07	1.72 ± 0.10	1.56 ± 0.07

^a Data are given as the number of bromodeoxyuridine-labeled nuclei/mm basement membrane (mean ± standard error).

2-YEAR STUDY**Survival**

Estimates of 2-year survival probabilities for male and female rats are shown in Table 10 and in the Kaplan-Meier survival curves (Figure 3). Survival of exposed males and females was similar to that of the chamber controls.

Body Weights and Clinical Findings

Mean body weights of females exposed to 2 mg/m³ were marginally less than those of the chamber controls throughout the 2-year study; mean body weights of exposed and chamber control males were similar throughout the study (Figure 4; Tables 11 and 12). No clinical findings related to vanadium pentoxide exposure were observed.

TABLE 10
Survival of Rats in the 2-Year Inhalation Study of Vanadium Pentoxide

	Chamber Control	0.5 mg/m ³	1 mg/m ³	2 mg/m ³
Male				
Animals initially in study	50	50	50	50
Moribund	25	17	18	13
Natural deaths	5	4	6	10
Animals surviving to study termination	20	29	26	27
Percent probability of survival at end of study ^a	40	58	52	54
Mean survival (days) ^b	668	680	692	671
Survival analysis ^c	P=0.386N	P=0.085N	P=0.138N	P=0.289N
Female				
Animals initially in study	50	50	50	50
Moribund	14	20	17	15
Natural deaths	3	6	4	5
Animals surviving to study termination	33	24	29	30
Percent probability of survival at end of study	66	48	58	60
Mean survival (days)	688	678	679	683
Survival analysis	P=0.917	P=0.119	P=0.522	P=0.621

^a Kaplan-Meier determinations

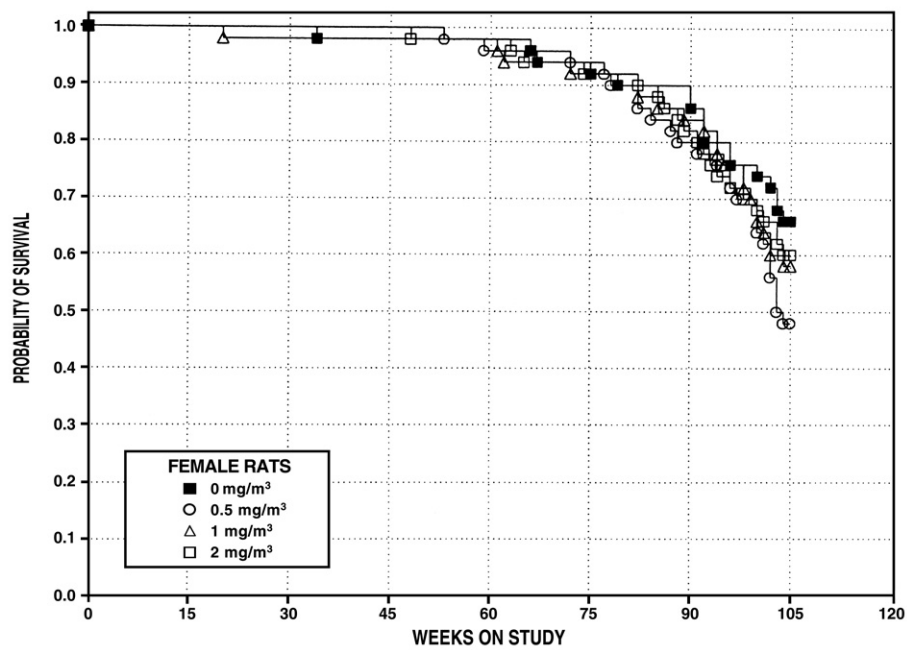
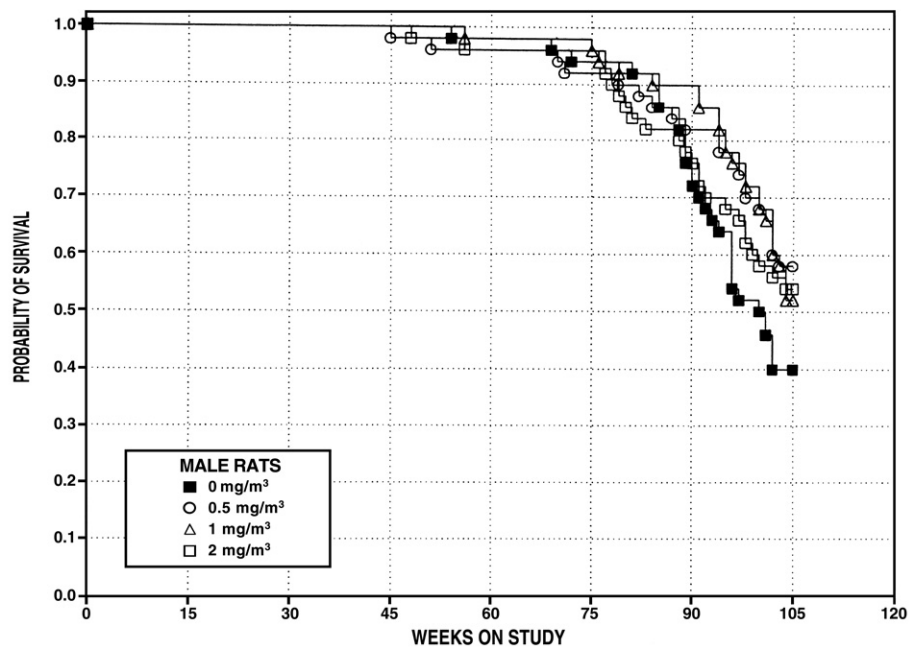

FIGURE 3
Kaplan-Meier Survival Curves for Male and Female Rats Exposed to Vanadium Pentoxide by Inhalation for 2 Years

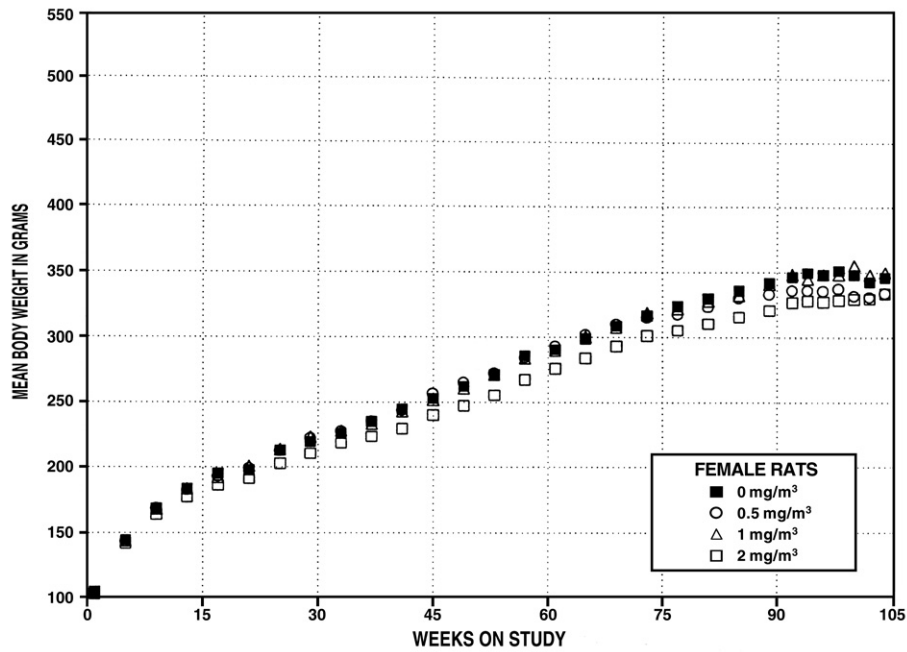
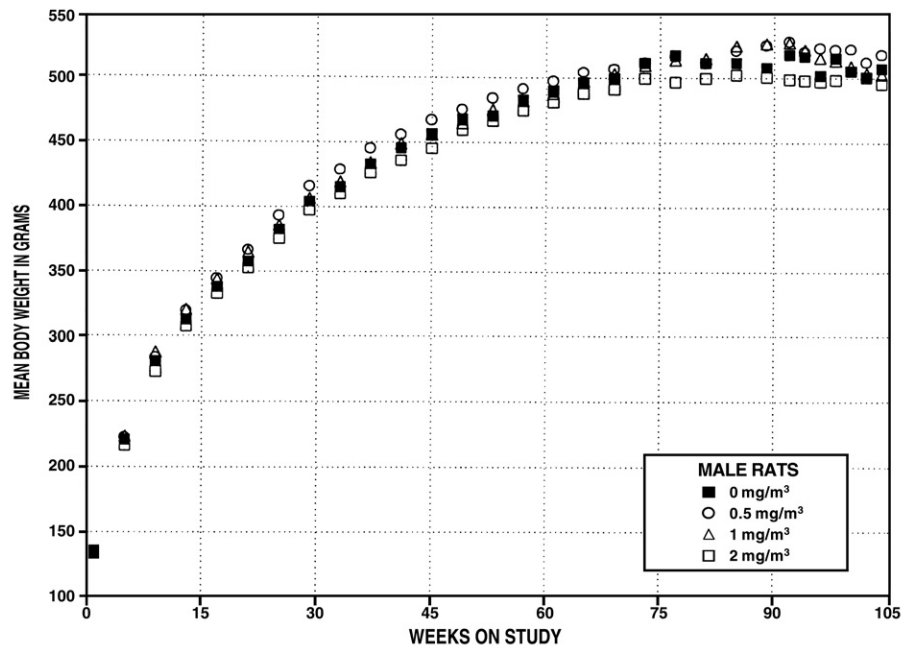

FIGURE 4
Growth Curves for Male and Female Rats Exposed to Vanadium Pentoxide
by Inhalation for 2 Years

TABLE 11
Mean Body Weights and Survival of Male Rats in the 2-Year Inhalation Study of Vanadium Pentoxide

Weeks on Study	Chamber Control		0.5 mg/m ³			1 mg/m ³			2 mg/m ³		
	Av. Wt. (g)	No. of Survivors	Av. Wt. (g)	Wt. (% of controls)	No. of Survivors	Av. Wt. (g)	Wt. (% of controls)	No. of Survivors	Av. Wt. (g)	Wt. (% of controls)	No. of Survivors
1	136	50	135	99	50	134	98	50	134	99	50
5	221	50	223	101	50	224	101	50	216	98	50
9	281	50	284	101	50	288	102	50	273	97	50
13	313	50	320	102	50	320	102	50	307	98	50
17	338	50	345	102	50	344	102	50	333	98	50
21	358	50	367	103	50	365	102	50	353	99	50
25	383	50	394	103	50	386	101	50	376	98	50
29	404	50	416	103	50	407	101	50	398	98	50
33	416	50	429	103	50	420	101	50	411	99	50
37	433	50	445	103	50	434	100	50	427	99	50
41	446	50	456	102	50	449	101	50	436	98	50
45	457	50	468	102	50	456	100	50	445	98	50
49	468	50	476	102	49	465	99	50	460	98	49
53	471	50	484	103	48	476	101	50	467	99	49
57	483	49	492	102	48	482	100	49	475	98	48
61	490	49	498	102	48	488	100	49	481	98	48
65	496	49	505	102	48	497	100	49	488	98	48
69	500	49	507	102	48	503	101	49	491	98	48
73	512	47	512	100	46	510	100	49	500	98	48
77	517	47	517	100	46	514	99	47	497	96	48
81	512	47	511	100	45	515	101	46	500	98	43
85	512	45	521	102	43	525	103	45	502	98	41
89	508	41	525	103	42	527	104	45	501	99	40
92	518	35	528	102	41	528	102	43	499	96	36
94	517	33	520	101	41	522	101	43	498	96	35
96	502	32	523	104	39	516	103	39	497	99	34
98	516	26	522	101	37	513	100	38	498	97	33
100	505	26	523	103	35	509	101	36	506	100	30
102	500	23	513	102	34	504	101	33	501	100	29
104	507	20	519	102	29	503	99	29	496	98	28
Mean for weeks											
1-13	238		241	101		242	102		233	98	
14-52	411		422	103		414	101		404	98	
53-104	504		513	102		508	101		494	98	

TABLE 12
Mean Body Weights and Survival of Female Rats in the 2-Year Inhalation Study of Vanadium Pentoxide

Weeks on Study	Chamber Control		0.5 mg/m ³			1 mg/m ³			2 mg/m ³		
	Av. Wt. (g)	No. of Survivors	Av. Wt. (g)	Wt. (% of controls)	No. of Survivors	Av. Wt. (g)	Wt. (% of controls)	No. of Survivors	Av. Wt. (g)	Wt. (% of controls)	No. of Survivors
1	105	50	104	99	50	104	99	50	103	98	50
5	145	50	144	99	50	144	100	50	142	98	50
9	169	50	169	100	50	168	100	50	164	97	50
13	183	50	182	100	50	184	100	50	177	97	50
17	195	50	193	99	50	192	99	50	186	95	50
21	198	50	199	101	50	201	102	49	191	97	50
25	213	50	213	100	50	214	100	49	203	95	50
29	220	50	223	102	50	223	102	49	211	96	50
33	226	50	228	101	50	228	101	49	219	97	50
37	235	49	236	100	50	233	99	49	224	95	50
41	245	49	244	100	50	243	99	49	230	94	50
45	253	49	257	102	50	252	100	49	240	95	50
49	262	49	266	101	50	261	99	49	248	94	49
53	272	49	273	100	50	271	100	49	256	94	49
57	286	49	285	100	49	284	99	49	268	94	49
61	291	49	294	101	48	290	100	49	276	95	49
65	299	49	302	101	48	301	101	47	284	95	48
69	309	47	310	101	48	308	100	47	293	95	47
73	317	47	316	100	47	319	101	46	301	95	47
77	324	46	318	98	47	322	99	46	306	94	46
81	330	45	324	98	45	328	100	46	311	94	46
85	336	45	330	98	42	332	99	44	316	94	45
89	342	45	333	98	40	341	100	43	321	94	42
92	346	43	336	97	39	348	101	42	327	94	40
94	350	40	336	96	39	345	99	41	328	94	38
96	348	40	336	96	38	348	100	38	327	94	37
98	351	38	338	96	35	348	99	38	329	94	36
100	348	38	332	95	35	356	102	35	330	95	35
102	342	37	331	97	31	348	102	32	330	96	33
104	346	34	334	97	25	350	101	30	334	96	31
Mean for weeks											
1-13	151		150	99		150	99		147	97	
14-52	227		229	101		227	100		217	96	
53-104	326		319	98		326	100		308	94	

Pathology and Statistical Analyses

This section describes the statistically significant or biologically noteworthy changes in the incidences of neoplasms and nonneoplastic lesions of the lung, larynx, nose, uterus, and kidney. Summaries of the incidences of neoplasms and nonneoplastic lesions, individual animal tumor diagnoses, statistical analyses of primary neoplasms that occurred with an incidence of at least 5% in at least one animal group, and historical incidences for the neoplasms mentioned in this section are presented in Appendix A for male rats and Appendix B for female rats.

Lung: Although there were no statistically significant increases in the incidences of lung neoplasms in rats, the incidences of alveolar/bronchiolar adenoma in 0.5 mg/m³ males and of alveolar/bronchiolar carcinoma and alveolar/bronchiolar adenoma or carcinoma (combined) in 0.5 and 2 mg/m³ males exceeded the historical ranges in controls (all routes) given NTP-2000 diet and in inhalation chamber controls given NIH-07 diet (Tables 13, A3, and A4). This response was considered related to exposure to vanadium pentoxide.

Alveolar/bronchiolar adenomas, typical of those occurring spontaneously, were generally distinct masses that often compressed surrounding tissue. Component epithelial cells were generally uniform in appearance and were arranged in acinar and/or irregular papillary structures and occasionally in a solid cellular pattern. Alveolar/bronchiolar carcinomas had similar cellular patterns but were generally larger and had one or more of the following histologic features: heterogeneous growth pattern, cellular pleomorphism and/or atypia, and local invasion or metastasis.

The incidence of alveolar/bronchiolar adenoma in 0.5 mg/m³ females was at the upper end of the historical control range for studies using NTP-2000 diet and exceeded the range in the larger database for inhalation studies using NIH-07 diet (Tables 13, B3, and B4). Additionally, one female exposed to 1 mg/m³ had an alveolar/bronchiolar adenoma, and one female exposed to 2 mg/m³ had an alveolar/bronchiolar carcinoma.

There were significantly increased incidences of alveolar epithelial hyperplasia and bronchiole hyperplasia in the lungs of males exposed to 0.5 mg/m³ or greater and females exposed to 1 or 2 mg/m³ (Tables 13, A5, and B5). The severities of these lesions were increased in 2 mg/m³ males and females. In affected animals, this

was essentially a diffuse change with proliferation of epithelium in the distal terminal bronchioles and immediately associated alveolar ducts and alveoli (Plates 1 and 2). Normally flattened epithelium was replaced with cuboidal epithelium (Plate 3).

Significantly increased incidences of squamous metaplasia of the alveoli occurred in male and, to a lesser extent, female rats exposed to 2 mg/m³ (Tables 13, A5, and B5). There was a spectrum of changes ranging from minimal to severe. Minimal lesions were characterized by a single alveolus with the thin type I cells which normally line alveoli replaced by one to several layers of squamous epithelium (Plate 4). Severe lesions were much larger, often involving an area approximately 1 cm in diameter (Plates 5, 6, and 7). Many alveoli were involved and there was apparent coalescence of the metaplasia. There were also lesions of intermediate severity (Plates 8 and 9). Keratin production was a prominent feature of the squamous metaplasia observed in this study. Keratin often filled the affected alveoli, and in some of the lesions, cyst-like structures filled with keratinous material were formed (Plate 10). In a few animals (predominantly males), the squamous metaplasia extended into the distal airways and was diagnosed as bronchiole squamous metaplasia. Commonly dispersed within the squamous lesions were areas of respiratory epithelial metaplasia (Plate 11) in which the alveolar epithelium was replaced by tall cuboidal to columnar epithelium with cilia often present and with mucous material filling the alveolar lumen.

Incidences of minimal to mild chronic active inflammation and interstitial fibrosis in the lungs were significantly increased in males exposed to 1 or 2 mg/m³ and females exposed to 2 mg/m³, and the incidences of histiocytic cellular infiltrate of the alveolus were increased in all exposed groups of males and females (Tables 13, A5, and B5). The inflammatory lesions were primarily minimal to mild and consisted of interstitial and perivascular infiltrates of mostly mononuclear inflammatory cells that were occasionally within alveoli. Alveolar septa were occasionally thickened by thin strands of eosinophilic fibrillar material (fibrosis). The histiocytic infiltrate was also minimal to mild, consisting of scattered intraalveolar macrophages that contained large amounts of foamy intracytoplasmic material, interpreted as pulmonary surfactant. Additionally, scant amounts of eosinophilic material (surfactant) similar to that observed within alveolar macrophages was also free within alveoli; however, a separate diagnosis was not

TABLE 13
Incidences of Neoplasms and Nonneoplastic Lesions of the Respiratory System in Rats
in the 2-Year Inhalation Study of Vanadium Pentoxide

	Chamber Control	0.5 mg/m ³	1 mg/m ³	2 mg/m ³
Male				
Lung ^a	50	49	48	50
Alveolar Epithelium, Hyperplasia ^b	7 (2.3) ^c	24** (2.0)	34** (2.0)	49** (3.3)
Bronchiole Epithelium, Hyperplasia	3 (2.3)	17** (2.2)	31** (1.8)	49** (3.3)
Alveolar Epithelium, Metaplasia, Squamous	1 (1.0)	0	0	21** (3.6)
Bronchiole Epithelium, Metaplasia, Squamous	0	0	0	7** (3.7)
Inflammation, Chronic Active	5 (1.6)	8 (1.8)	24** (1.3)	42** (2.4)
Interstitial, Fibrosis	7 (1.4)	7 (2.0)	16* (1.6)	38** (2.1)
Alveolus, Infiltration Cellular, Histiocyte	22 (1.3)	40** (2.0)	45** (2.3)	50** (3.3)
Alveolus, Pigmentation	1 (2.0)	0	2 (1.5)	28** (2.1)
Alveolar/bronchiolar Adenoma, Multiple	0	2	0	0
Alveolar/bronchiolar Adenoma (includes multiple) ^d	4	8	5	6
Alveolar/bronchiolar Carcinoma, Multiple	0	1	0	0
Alveolar/bronchiolar Carcinoma (includes multiple) ^e	0	3	1	3
Alveolar/bronchiolar Adenoma or Carcinoma ^f				
Overall rate ^g	4/50 (8%)	10/49 (20%)	6/48 (13%)	9/50 (18%)
Adjusted rate ^h	10.0%	23.3%	14.0%	21.3%
Terminal rate ⁱ	4/20 (20%)	8/29 (28%)	4/26 (15%)	6/27 (22%)
First incidence (days)	729 (T)	608	694	558
Poly-3 test ^j	P=0.232	P=0.092	P=0.416	P=0.134
Larynx	49	50	50	49
Inflammation, Chronic	3 (1.0)	20** (1.1)	17** (1.5)	28** (1.6)
Respiratory Epithelium, Epiglottis, Degeneration	0	22** (1.1)	23** (1.1)	33** (1.5)
Respiratory Epithelium, Epiglottis, Hyperplasia	0	18** (1.5)	34** (1.5)	32** (1.9)
Respiratory Epithelium, Epiglottis, Metaplasia, Squamous	0	9** (1.7)	16** (1.8)	19** (2.1)
Nose	49	50	49	48
Goblet Cell, Respiratory Epithelium, Hyperplasia	4 (1.8)	15** (1.8)	12* (2.0)	17** (2.1)

TABLE 13
Incidences of Neoplasms and Nonneoplastic Lesions of the Respiratory System in Rats
in the 2-Year Inhalation Study of Vanadium Pentoxide

	Chamber Control	0.5 mg/m ³	1 mg/m ³	2 mg/m ³
Female				
Lung	49	49	50	50
Alveolar Epithelium, Hyperplasia	4 (1.0)	8 (1.8)	21** (1.2)	50** (3.1)
Bronchiole Epithelium, Hyperplasia	6 (1.5)	5 (1.6)	14* (1.3)	48** (3.0)
Alveolar Epithelium, Metaplasia, Squamous	0	0	0	6* (3.0)
Bronchiole Epithelium, Metaplasia, Squamous	0	0	0	1 (2.0)
Inflammation, Chronic Active	10 (1.5)	10 (1.1)	14 (1.2)	40** (1.7)
Interstitial, Fibrosis	19 (1.4)	7** (1.3)	12 (1.6)	32** (1.4)
Alveolus, Infiltration Cellular, Histocyte	26 (1.4)	35* (1.3)	44** (2.0)	50** (3.1)
Alveolus, Pigmentation	1 (1.0)	1 (1.0)	8* (1.3)	7* (1.9)
Alveolar/bronchiolar Adenoma ^k				
Overall rate	0/49 (0%)	3/49 (6%)	1/50 (2%)	0/50 (0%)
Adjusted rate	0.0%	7.3%	2.4%	0.0%
Terminal rate	0/33 (0%)	2/24 (8%)	1/29 (3%)	0/30 (0%)
First incidence (days)	—	675	731 (T)	—
Poly-3 test	P=0.381N	P=0.108	P=0.496	— ^m
Alveolar/bronchiolar Carcinoma	0	0	0	1
Alveolar/bronchiolar Adenoma or Carcinoma ⁿ	0	3	1	1
Larynx	50	49	49	50
Inflammation, Chronic	8 (1.8)	26** (1.5)	27** (1.3)	37** (1.4)
Respiratory Epithelium, Epiglottis, Degeneration	2 (1.0)	33** (1.2)	26** (1.2)	40** (1.5)
Respiratory Epithelium, Epiglottis, Hyperplasia	0	25** (1.4)	26** (1.3)	33** (1.5)
Respiratory Epithelium, Epiglottis, Metaplasia, Squamous	2 (2.0)	7 (1.9)	7 (1.7)	16** (1.4)
Nose	50	50	50	50
Goblet Cell, Respiratory Epithelium, Hyperplasia	13 (2.0)	18 (2.0)	16 (1.9)	30** (2.0)

(T) Terminal sacrifice

* Significantly different ($P \leq 0.05$) from the chamber control group by the Poly-3 test

** $P \leq 0.01$

^a Number of animals examined microscopically

^b Number of animals with lesion

^c Average severity grade of lesions in affected animals: 1=minimal, 2=mild, 3=moderate, 4=marked

^d Historical incidence for 2-year studies with controls given NTP-2000 diet (mean \pm standard deviation): 24/609 (4.2% \pm 3.5%), range 0%-12%; with inhalation chamber controls given NIH-07 diet: 18/1,054 (1.7% \pm 2.4%), range 0%-10%

^e Historical incidence for NTP-2000 diet: 2/609 (0.4% \pm 0.8%), range 0%-2%; for NIH-07 diet: 8/1,054 (0.8% \pm 1.2%), range 0%-4%

^f Historical incidence for NTP-2000 diet: 26/609 (4.5% \pm 3.9%), range 0%-14%; for NIH-07 diet: 26/1,054 (2.5% \pm 2.6%), range 0%-10%

^g Number of animals with neoplasm per number of animals examined microscopically

^h Poly-3 estimated neoplasm incidence after adjustment for intercurrent mortality

ⁱ Observed incidence at terminal kill

^j Beneath the chamber control incidence is the P value associated with the trend test. Beneath the exposed group incidence are the P values corresponding to pairwise comparisons between the chamber controls and that exposed group. The Poly-3 test accounts for the differential mortality in animals that do not reach terminal sacrifice. A negative trend is indicated by N.

^k Historical incidence for NTP-2000 diet: 12/658 (1.7% \pm 2.0%), range 0%-6%; for NIH-07 diet: 12/1,050 (1.1% \pm 1.3%), range 0%-4%

^l Not applicable; no neoplasms in animal group

^m Value of statistic cannot be computed.

ⁿ Historical incidence for NTP-2000 diet: 15/658 (2.1% \pm 2.0%), range 0%-6%; for NIH-07 diet: 14/1,050 (1.3% \pm 1.5%), range 0%-4%

made. A brownish pigment (pigmentation) was visible in alveolar macrophages in some males and females exposed to 2 mg/m³ and in females exposed to 1 mg/m³; it was a mild change considered of little biological significance and was not further characterized.

In addition to the core groups of animals in the 2-year study, five female rats designated for tissue burden studies were evaluated on days 1, 5, 12, 26, 54, 173, 360, and 542. The left lung lobe from each animal was infused with 10% neutral buffered formalin, and sections were examined microscopically. The purpose was to follow progression of the lung lesions. While these data are not included in this Technical Report, the findings are summarized here. Following day 1 of exposure, there was an infiltrate of alveolar macrophages in the lungs. With continued exposure, increased numbers of alveolar macrophages, interstitial mononuclear inflammatory cell infiltrates, and hyperplasia of alveolar and bronchiolar epithelium were observed. In rats exposed to 2 mg/m³, there was an increase in severity of the hyperplasia between days 54 and 173. An increase in severity was not obvious between days 173 and 360, but hyperplasia appeared more severe on day 542. Hyperplasia was observed in only a few animals exposed to 1 mg/m³ and only on day 542. The minimal fibrosis observed in the 2-year study was not readily apparent on day 542 or earlier.

Larynx: There were increased incidences of minimal to mild lesions of the larynx in males and females exposed to vanadium pentoxide (Tables 13, A5, and B5). The incidences generally increased with increasing exposure concentration and included chronic inflammation of the larynx and degeneration, hyperplasia, and squamous metaplasia of the respiratory epithelium of the epiglottis. The inflammation consisted of a mixture of mononuclear and granulocytic inflammatory cells in the submucosa beneath the epithelium lining the base of the epiglottis, ventral pouch, and caudal larynx. The degeneration of the respiratory epithelium was characterized by a loss or decrease in the height of cilia and shortening of the normally columnar to cuboidal surface epithelial cells lining the laryngeal surface of the base of the epiglottis. Squamous metaplasia was diagnosed when the ciliated cells were replaced by one or more layers of flattened squamous epithelium. In the same area, the respiratory epithelium was mildly thickened in many animals; this change was diagnosed as hyperplasia. These changes are relatively minimal, commonly occur in rats in NTP inhalation studies, and represent a common response to laryngeal injury.

Nose: There were increased incidences of mild goblet cell hyperplasia of the nasal respiratory epithelium in all groups of exposed male rats and in females exposed to 2 mg/m³ (Tables 13, A5, and B5). Increased numbers of goblet cells were most notable in the respiratory epithelium lining the median septum adjacent to the area of the vomeronasal organ.

Uterus: The incidences of stromal polyp occurred with a positive trend in female rats (chamber control, 6/50; 0.5 mg/m³, 3/50; 1 mg/m³, 7/50; 2 mg/m³, 13/50; Table B3). However, the incidence in the 2 mg/m³ group was within the historical range in controls (all routes) given NTP-2000 diet [115/659 (17.7% ± 5.6%), range 12%-31%]. Endometrial stromal polyps are common neoplasms in the F344/N rat in NTP studies. They are benign neoplasms and generally do not progress to malignancy; however, they occasionally do progress to stromal sarcoma. In this study, when the incidences of stromal polyp were combined with the single incidence of stromal sarcoma (0/50, 0/50, 0/50, 1/50; Table B1), the combined incidence in 2 mg/m³ females was significantly increased. The marginal increase in the incidence of stromal polyp and stromal sarcoma (combined) in females exposed to 2 mg/m³ was not considered related to exposure to vanadium pentoxide. A review of NTP studies reveals that chemical induction of uterine stromal polyps is rare, with only two early studies showing increased incidences (NCI, 1978, 1979).

Kidney: The incidences of nephropathy (37/50, 42/50, 46/49, 47/50; Table A5) were significantly increased in male rats exposed to 1 or 2 mg/m³. Nephropathy is a common lesion in aged rats, particularly males, and has been diagnosed in virtually all males in NTP 2-year studies that used the NIH-07 diet. In those studies, chemical exacerbation of nephropathy was identified by increased severity. With the NTP-2000 diet, the severity of spontaneous nephropathy has been reduced. In this study, the severity of nephropathy (chamber control, 2.4; 0.5 mg/m³, 2.1; 1 mg/m³, 2.1; 2 mg/m³, 2.3) was not increased in exposed groups of males. Also, exposed females were not affected (24/50, 21/50, 20/49, 32/50). Although the NTP doesn't have a formal historical control database for nonneoplastic lesions, a review of recent studies indicates that the incidence in the male chamber control group in the current study is low. It is not clear if the increased incidences in this study were related to exposure to vanadium or were a reflection of the low incidence in the control group. Regardless, nephropathy was a relatively weak response and was likely of marginal biological significance.

Tissue Burden Analyses

Tissue burden analyses were performed on female rats exposed to 0.5, 1, or 2 mg/m³ on days 1, 5, 12, 26, 54, 173, 360, and 540. Lung weights from exposed female rats increased throughout the study (Table K4). Although there appeared to be an exposure concentration-related increase in lung weights after day 26 of the study, it was primarily due to increases in lung weights of female rats exposed to 2 mg/m³. In general, lung weights of 0.5 or 1 mg/m³ females were similar, although there was a trend for lung weights of 1 mg/m³ females to be slightly greater, especially towards the end of the study.

Various tests used to determine if lung burdens were proportional to exposure concentration gave contradictory results. Simple visual inspection of the lung burden data indicates that lung burdens increased roughly in proportion to exposure concentration (Figure 5A and Table K4). Lung burdens normalized to exposure concentration would be expected to remain constant across all exposure concentrations if the toxicokinetics were linear. However, in this study, normalized lung burdens at individual time points indicated that lung burden did not increase proportionally at the majority of the time points even though there were some time points that were proportional (Figure 5B). Conversely, areas under the lung burden versus time curves (AUC) definitely increased in proportion to exposure concentration (Table K5). Normalized AUCs were similar, also indicating linearity (Table K5). Although proportionality may not have been evident when examined at several individual time points, departures from proportional behavior were small. However, when lung burden data were integrated over all time points, they did appear to be approximately proportional to exposure concentration.

Also complicating the overall assessment of vanadium pentoxide lung deposition and clearance was that during the 2-year study, lung burdens in the 1 and 2 mg/m³ groups did not reach steady state (i.e., equilibrium between lung deposition and clearance). Rather, lung burdens in the 1 and 2 mg/m³ groups increased through day 173 at which time they peaked and then declined until day 542, while lung burdens in the 0.5 mg/m³ group increased with time and appeared to reach steady state by day 173 (Figure 5A). Attempts to fit commonly used lung burden models that assume a constant deposition rate and proportional clearance rate were unsuccessful with these data except in the 0.5 mg/m³ group. Therefore, a model was developed (Appendix K) that

allowed the deposition rate to decrease with time on study, and the model fit the lung data for each exposure concentration well. Initial deposition rates normalized to exposure concentration were not constant and decreased slightly with exposure concentration, indicating the initial deposition rate of vanadium increased as the exposure concentration increased; however, this increase was less than proportional. In addition, there was a clear time-dependent decline in the calculated deposition rate in the 1 mg/m³ (0.41 to 0.25 µg/day) and 2 mg/m³ (0.68 to 0.48 µg/day) groups between days 1 and 542. However, there was no change in the deposition rate in the 0.5 mg/m³ group (approximately 0.22 µg/day) throughout the study. The most likely explanation for the decreased deposition rates in the 1 and 2 mg/m³ groups is a change in pulmonary function brought about by vanadium pentoxide-induced alterations in the airways and alveoli of the lung, as observed in the 3-month study. Although there were no significant differences in clearance rates between the 1 and 2 mg/m³ groups, when each was compared to the clearance rate of the 0.5 mg/m³ group, they were decreased. Clearance half-times in the 16-day special study were 4.42 to 4.96 days for the 1 and 2 mg/m³ groups (Table K2); however, the clearance half-times in the 2-year study were much longer: 37, 59, and 61 days for the 0.5, 1, and 2 mg/m³ groups, respectively (Table K5). Therefore, it appears that vanadium is cleared more rapidly from the lungs of rats exposed to vanadium pentoxide for short periods of time or at low concentrations repeatedly for longer periods. Deposition and clearance rates are clearly dependent on exposure concentrations and time on exposure. In the present study, deposition and clearance rates decreased in the 1 and 2 mg/m³ groups. A possible explanation for lung burden data that appeared to be proportional to exposure concentration is that both deposition and clearance rates decreased similarly in the 1 and 2 mg/m³ groups.

Because deposition rates for the 1 and 2 mg/m³ groups decreased over time while the deposition rate in the 0.5 mg/m³ group remained relatively constant, it is of importance to estimate the total vanadium lung “dose” and to determine if the lung dose was proportional to exposure concentration. Integrating the deposition rate curves over 542 days of the study (Figure 6) provides an estimate of the total vanadium lung dose (µg vanadium) that rats received at each exposure concentration. For rats, total lung dose was estimated to be 130, 175 and 308 µg vanadium for the 0.5, 1, and 2 mg/m³ groups, respectively. Therefore, there was less than a three-fold difference in total lung dose from the high (2 mg/m³) to

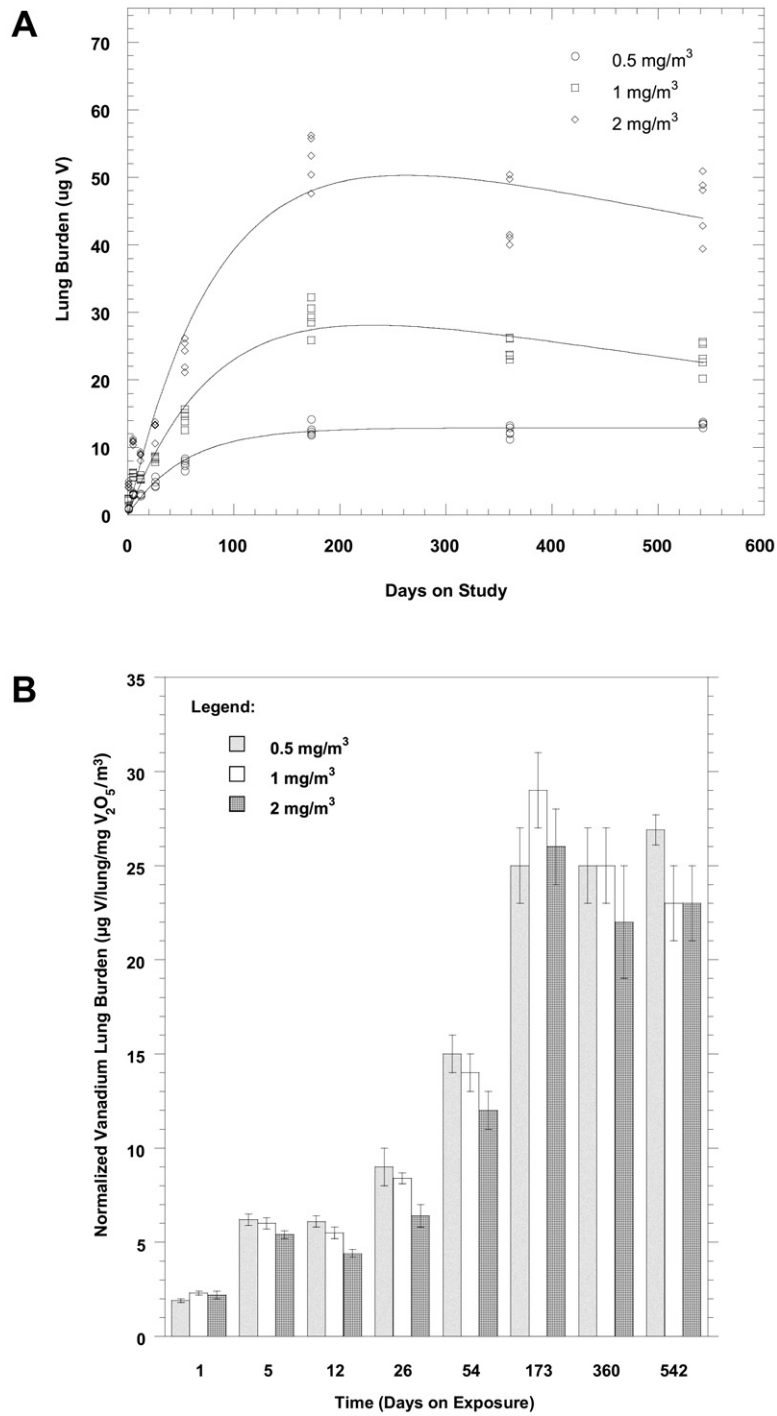

FIGURE 5
Lung Burden (µg V) (A) and Normalized Lung Burden (µg V/Lung per mg V₂O₅/m³) (B) of Vanadium in Female Rats in the 2-Year Inhalation Study of Vanadium Pentoxide.
 Data are presented as mean ± standard deviation. Curves represent the fit of the lung deposition and clearance model to the data.

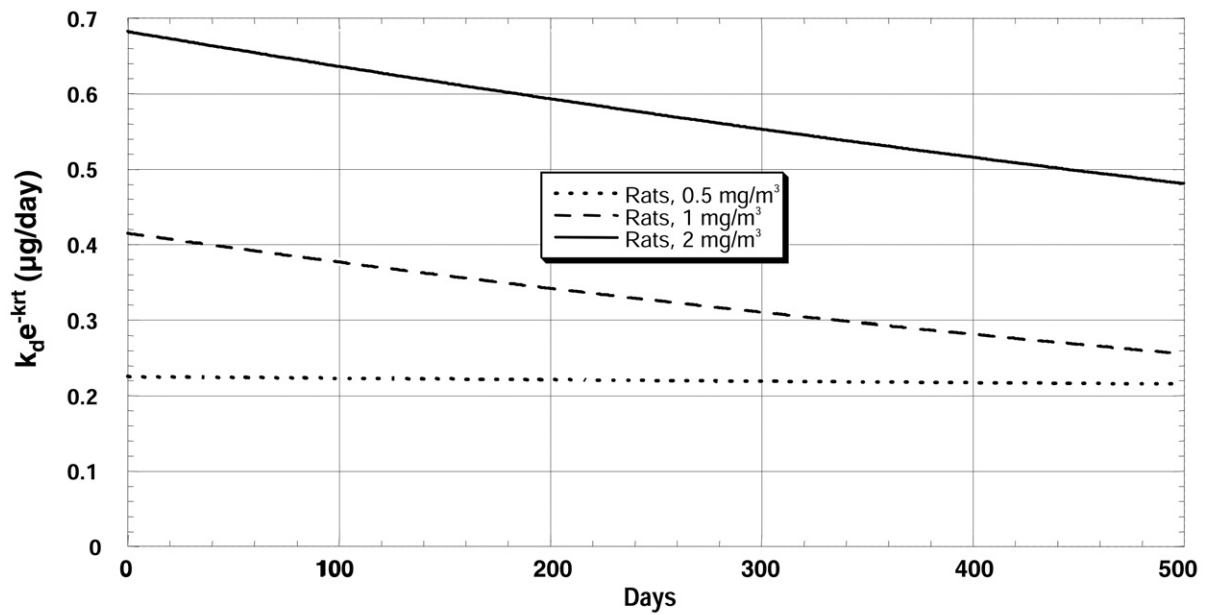

FIGURE 6
Calculated Vanadium Lung Deposition Rates in Female Rats in the 2-Year Inhalation Study of Vanadium Pentoxide.

Data are based on deposition rates determined from the model.

low (0.5 mg/m^3) exposure concentrations. In fact, when the total lung dose for each group was normalized to exposure concentration ($\mu\text{g vanadium/mg V}_2\text{O}_5 \text{ per m}^3$) the normalized doses were 260, 175, and $154 \mu\text{g vanadium per mg/m}^3$, indicating that the normalized lung dose was not constant due to the reduced deposition of vanadium with increasing exposure concentration. Based on the last measured lung burdens, rats appeared to retain about 10% to 15% of the total estimated lung doses on day 542.

Vanadium was detected in the blood at concentrations several orders of magnitude lower than those measured in the lungs of exposed rats, and blood vanadium

concentrations in exposed groups were only marginally increased over that of the chamber control group (Table K6). Overall, blood vanadium concentrations appeared to increase with increasing exposure concentration; however, this proportionality was less clear when the 0.5 and 1 mg/m^3 groups were compared. Blood vanadium concentrations in all exposed groups appeared to peak on days 26 or 54 after which there was a decline throughout the rest of the study. This response was similar to that seen in lung burdens. However, these changes in concentrations were small, making it difficult to determine if there was an increase in elimination of vanadium from the blood or a decreased absorption from the lung due to reduced deposition, especially at the higher exposure concentrations.

MICE

16-DAY STUDY

All males exposed to 32 mg/m³ died or were killed moribund and one male exposed to 8 mg/m³ died before the end of the study (Table 14). Final mean body weights and body weight gains of 16 mg/m³ males and 32 mg/m³ females were significantly less than those of the chamber controls; 32 mg/m³ females lost weight during the study.

Additionally, final mean body weights of 8 and 16 mg/m³ females were significantly less than those of the chamber controls. Hypoactivity was observed in the 32 mg/m³ groups; one of the affected females also had labored breathing. Some males in the 32 mg/m³ groups had hunched posture, and one was emaciated.

TABLE 14
Survival and Body Weights of Mice in the 16-Day Inhalation Study of Vanadium Pentoxide

Concentration (mg/m ³)	Survival ^a	Mean Body Weight ^b (g)			Final Weight Relative to Controls (%)
		Initial	Final	Change	
Male					
0	5/5	23.5 ± 0.9	28.0 ± 0.5	4.5 ± 0.4	
2	5/5	23.6 ± 0.3	27.7 ± 0.4	4.1 ± 0.5	99
4	5/5	23.7 ± 0.4	27.3 ± 0.5	3.6 ± 0.3	97
8	4/5 ^c	23.4 ± 0.2	26.7 ± 0.7	3.3 ± 0.5	95
16	5/5	23.6 ± 0.2	26.1 ± 0.6*	2.5 ± 0.5**	93
32	0/5 ^d	23.5 ± 0.4	—	—	—
Female					
0	5/5	19.5 ± 0.4	22.9 ± 0.2	3.5 ± 0.3	
2	5/5	18.2 ± 0.4	22.2 ± 0.1	4.1 ± 0.4	97
4	5/5	19.5 ± 0.5	21.9 ± 0.3	2.4 ± 0.4	96
8	5/5	19.3 ± 0.5	20.7 ± 0.4**	1.5 ± 0.4	90
16	5/5	18.4 ± 0.2	20.8 ± 0.4**	2.4 ± 0.3	91
32	5/5	18.9 ± 0.5	16.6 ± 0.7**	-2.4 ± 1.0**	72

* Significantly different ($P \leq 0.05$) from the chamber control group by Williams' test

** $P \leq 0.01$

^a Number of animals surviving at 16 days/number initially in group

^b Weights and weight changes are given as mean ± standard error. Subsequent calculations are based on animals surviving to the end of the study. No final mean body weights or body weight gains were calculated for groups with 100% mortality.

^c Day of death: 7

^d Day of death: 9, 11, 12, 14, 14

Absolute and relative lung weights of 4 mg/m³ or greater males and all exposed groups of females were significantly greater than those of the chamber controls (Table H3). In addition, liver weights of 16 mg/m³ males were significantly greater. Other organ weight differences were considered to be related to body weight decreases. Thymus weights were similar to those of the chamber controls in all exposed groups except 32 mg/m³ females. Mediastinal lymph nodes of several males and females exposed to 2 (females only), 4, 8, or 16 mg/m³ were enlarged. While complete histopathology was not done, grossly enlarged nodes were confirmed histologically as lymphoid hyperplasia (data not presented).

A localized inflammatory response in the lung was evident based on increases in cell number, protein, lympho-

cytes, neutrophils, and lysozymes in lavage fluid. There was also a significant decrease in macrophages in lavage fluid. There were no effects on systemic immunity as evidenced by normal responses to *Klebsiella pneumoniae* and influenza virus. Other measures of immune function were not considered to be significantly different than those of the chamber controls (Appendix J).

Exposure Concentration Selection Rationale: Based on decreased survival of 32 mg/m³ males and body weight reduction in the 32 mg/m³ females, exposure concentrations greater than 16 mg/m³ were considered too high for use in a 3-month study. Therefore, the exposure concentrations selected for the 3-month inhalation study in mice were 0, 1, 2, 4, 8, and 16 mg/m³.

3-MONTH STUDY

One male exposed to 16 mg/m³ died before the end of the study (Table 15). Final mean body weights and body weight gains of 8 and 16 mg/m³ males and of 4 mg/m³ or greater females were significantly less than those of the chamber controls. The mouse that died early appeared thin. There were no other clinical findings related to vanadium pentoxide exposure.

Absolute and relative lung weights of males and females exposed to 4 mg/m³ or greater were significantly greater than those of the chamber controls (Table H4). The absolute lung weight was also significantly increased in

males exposed to 2 mg/m³. Other organ weight changes were considered related to body weight decreases.

The epididymal spermatozoal motility of males exposed to 8 or 16 mg/m³ was significantly decreased (Table I3). No significant differences were noted in estrous cycle parameters between exposed and chamber control females (Table I4).

Gross findings were observed in males and females exposed to 8 or 16 mg/m³ and included lungs that were pale or contained white or red (females) foci; the lungs of males in these groups were sometimes gray or mottled.

TABLE 15
Survival and Body Weights of Mice in the 3-Month Inhalation Study of Vanadium Pentoxide

Concentration (mg/m ³)	Survival ^a	Mean Body Weight ^b (g)			Final Weight Relative to Controls (%)
		Initial	Final	Change	
Male					
0	10/10	25.8 ± 0.3	34.2 ± 1.0	8.4 ± 0.9	
1	10/10	26.4 ± 0.3	33.9 ± 0.9	7.4 ± 0.8	99
2	10/10	26.2 ± 0.4	34.4 ± 0.6	8.2 ± 0.6	101
4	10/10	26.0 ± 0.4	33.7 ± 0.6	7.7 ± 0.5	98
8	10/10	25.9 ± 0.4	32.1 ± 0.3*	6.2 ± 0.2*	94
16	9/10 ^c	25.2 ± 0.3	31.0 ± 0.5**	5.6 ± 0.7**	90
Female					
0	10/10	20.3 ± 0.2	30.0 ± 1.0	9.7 ± 1.0	
1	10/10	19.8 ± 0.4	29.8 ± 0.7	10.0 ± 1.0	99
2	10/10	21.4 ± 0.3	29.5 ± 0.4	8.1 ± 0.4	98
4	10/10	21.0 ± 0.3	26.8 ± 0.4**	5.8 ± 0.5**	89
8	10/10	21.0 ± 0.4	27.0 ± 0.4**	6.1 ± 0.4**	90
16	10/10	20.9 ± 0.5	26.3 ± 0.4**	5.4 ± 0.3**	88

* Significantly different ($P \leq 0.05$) from the chamber control group by Williams' test

** $P \leq 0.01$

^a Number of animals surviving at 3 months/number initially in group

^b Weights and weight changes are given as mean ± standard error. Subsequent calculations are based on animals surviving to the end of the study.

^c Week of death: 11

The incidences of inflammation of the lung were increased in mice exposed to 2 mg/m³ or greater. Mice exposed to 2 mg/m³ or greater had epithelial hyperplasia of the lung (Table 16). The severities of these lesions generally increased with increasing exposure concentration. Inflammation was characterized by multiple foci of a mixed cellular infiltrate oriented around blood vessels and bronchioles. The infiltrate was composed primarily of macrophages with abundant cytoplasm and fewer lymphocytes and neutrophils. The infiltrate extended into the surrounding perivascular interstitium and often filled adjacent alveoli. Hyperplasia involved alveolar and, to a lesser extent, bronchiolar epithelium. This change involved the distal airways and associated alveolar ducts and alveoli. Normally flattened epithelium was replaced with larger cuboidal cells.

Lymphoid depletion of the thymus was observed in some males and females in the 16 mg/m³ groups (males: chamber control, 0/9; 8 mg/m³, 0/8; 16 mg/m³, 2/7; females: 0/9, 0/9, 1/10). This lesion may have been associated with the body weight decreases and debilitation of the mice.

Exposure Concentration Selection Rationale: Based on reduced body weight gain of 8 and 16 mg/m³ males and females and increased incidences of inflammation and epithelial hyperplasia of the lung in 8 and 16 mg/m³ males and females, exposure concentrations greater than 4 mg/m³ were considered too high for use in a 2-year study. The exposure concentrations selected for the 2-year inhalation study in mice were 1, 2, and 4 mg/m³.

TABLE 16
Incidences of Selected Nonneoplastic Lesions of the Lung in Mice
in the 3-Month Inhalation Study of Vanadium Pentoxide

	Chamber Control	1 mg/m ³	2 mg/m ³	4 mg/m ³	8 mg/m ³	16 mg/m ³
Male						
Number Examined Microscopically	10	10	10	10	10	10
Inflammation ^a	0	1 (1.0) ^b	3 (1.0)	4* (1.0)	10** (2.0)	10** (2.0)
Epithelium, Hyperplasia	0	1 (1.0)	4* (1.0)	5* (1.0)	10** (1.3)	10** (3.0)
Female						
Number Examined Microscopically	10	9	10	9	10	10
Inflammation	0	1 (1.0)	7** (1.0)	9** (1.1)	10** (1.9)	10** (2.5)
Epithelium, Hyperplasia	0	0	6** (1.0)	7** (1.0)	10** (1.5)	10** (2.5)

* Significantly different ($P \leq 0.05$) from the chamber control group by the Fisher exact test

** $P \leq 0.01$

^a Number of animals with lesion

^b Average severity grade of lesions in affected animals: 1=minimal, 2=mild, 3=moderate, 4=marked

16-DAY SPECIAL STUDY

A 16-day special study was conducted to determine blood and lung concentrations of vanadium, the lung clearance half-time of vanadium, and the onset and extent of vanadium pentoxide-induced lung injury. Female mice were exposed to 0, 2, or 4 mg/m³ for 14 days, and concentrations of vanadium in whole blood and lung tissue were determined. Elimination of vanadium from these tissues for a period up to 8 days post-exposure was also determined. Cell proliferation rates were determined from lung tissue taken from 10 animals per group on days 6 and 13; microscopic examination of lung tissue was conducted on an additional 10 animals per group at each of these time points. In addition, the onset and extent of lung lesions in 0, 2, 4, or 8 mg/m³ females were evaluated in lung tissue collected from four animals per group on days 1, 2, 5, 10, and 16.

Tissue burden analyses and lung and blood vanadium concentration analyses were performed on female mice immediately following exposure on day 16 and on post-exposure days 1, 4, and 8. Lung weights of exposed mice were significantly greater than those of the chamber controls; there was little difference in lung weights among the exposed groups (Table K7). The lung weights of exposed mice remained greater than those of the chamber controls through day 4 of recovery but were similar to those of the chamber controls on day 8. In general, lung burdens were proportional to exposure concentration throughout the recovery period. The area under the lung burden curves also indicated lung burden proportionality (Table K7). In addition, lung burdens normalized to exposure concentration were generally similar, indicating linear kinetics (Figure 7). Calculated lung clearance half-times during the 8-day recovery period were not significantly different among exposure groups (2.55 to 2.40 days) (Table K8). However, mice did clear vanadium from their lungs much faster than did rats.

Although vanadium was detected in the blood of exposed and chamber control mice, blood vanadium concentrations were highly variable. In most instances, blood vanadium concentrations in chamber control as well as in exposed mice were below the limit of quantitation (37 of 45 data points for all groups at all time points); therefore, these data are not included in Appendix K. Based on these data, it was difficult to

distinguish differences in blood vanadium concentrations in exposed versus chamber control mice. Although there were measurable amounts of vanadium, albeit very low concentrations, in the blood of exposed rats, the low blood vanadium concentrations in exposed mice may be due to the fact that exposed mice cleared vanadium from the lung much faster than did rats. Therefore, less vanadium was available systemically.

The following is a description of the pathology changes observed in the 10 mice examined on days 6 and 13 (Table 17). To allow identification of exposure-concentration and/or time-related increases in lesion severity, the grade of mild was used; however, the pulmonary changes observed in these animals were minimal. Hyperplasia of the alveolar and bronchiolar epithelium was observed in almost every exposed mouse, and the severity of hyperplasia generally increased with increasing exposure concentration and time. The hyperplasia was minimal to mild in all cases and involved the distal airways and alveolar ducts and alveoli. Minimal numbers of alveolar macrophages (histiocytic infiltrate) were also observed in the alveoli of mice exposed to 8 mg/m³ on days 6 and 13 and in mice exposed to 4 mg/m³ on day 13. Minimal to mild interstitial inflammation was observed in most mice exposed for 13 days. This change was characterized by small numbers of mononuclear cells around vessels, small airways, and sometimes extending into septae of alveolar ducts.

The lungs were evaluated histologically from four mice exposed for 1, 2, 5, 10, or 16 days (data not shown). Lungs from animals exposed for 1 or 2 days revealed no significant differences between chamber control and exposed groups. Lesions similar to those described above were observed on days 5, 10, and 16 with interstitial inflammation first observed at 10 days. As above, lesions were minimal to mild and tended to increase in incidence and/or severity with time and increasing exposure concentration.

Cell turnover rates in the terminal bronchioles increased with increasing exposure concentration on day 6 and were elevated in all exposed groups on day 13 (Table 18). Cell turnover rates in the alveoli and alveolar duct areas were elevated in an exposure concentration-related manner on day 13, but only in the 8 mg/m³ groups on day 6.

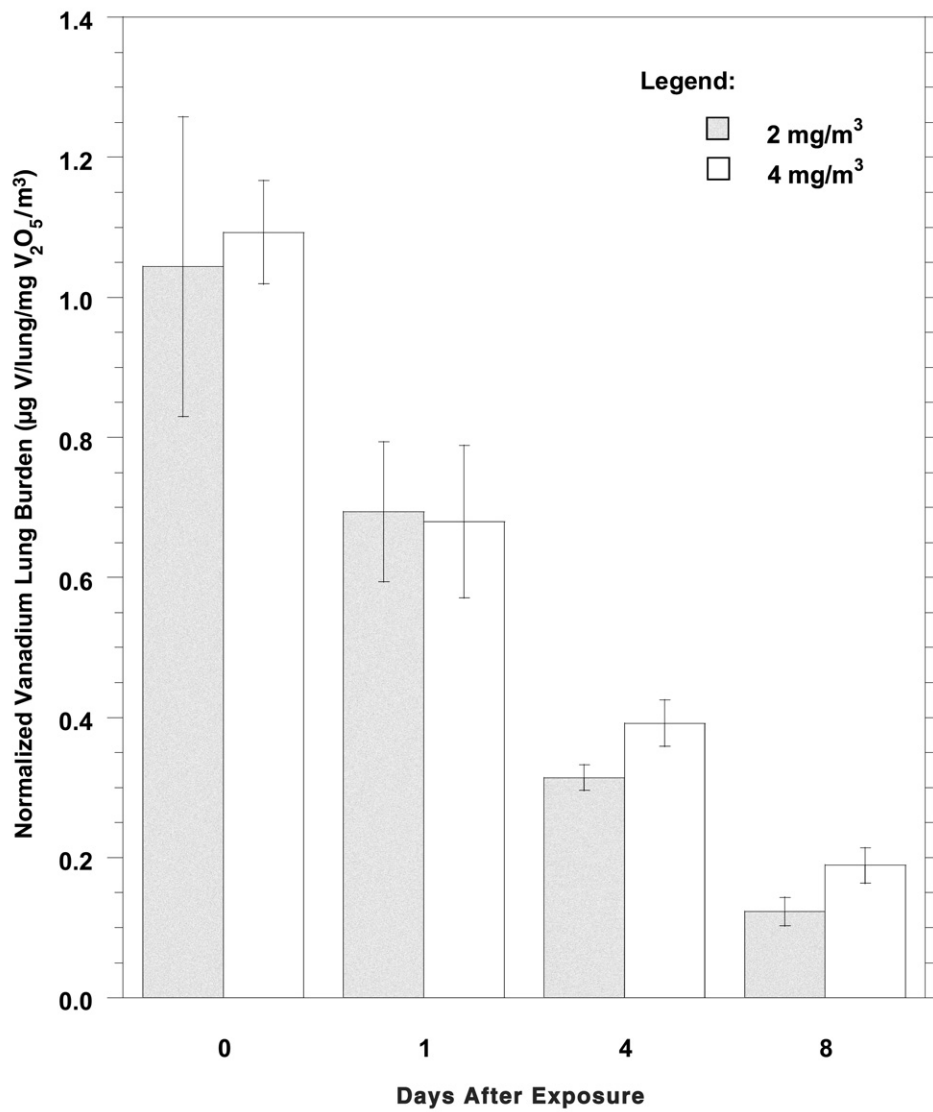

FIGURE 7
Normalized Lung Burden of Vanadium ($\mu\text{g V/Lung per mg V}_2\text{O}_5/\text{m}^3$)
in Female Mice Following 16 Days of Exposure to Vanadium Pentoxide.
 Data are presented as mean \pm standard deviation.

TABLE 17
Incidences of Nonneoplastic Lesions of the Lung in Female Mice
in the 16-Day Special Study of Vanadium Pentoxide

	Chamber Control	2 mg/m ³	4 mg/m ³	8 mg/m ³
Day 6				
Number Examined Microscopically	10	10	10	10
Alveolar Epithelium, Hyperplasia ^a	0	9** (1.0) ^b	10** (1.1)	9** (1.3)
Bronchiole Epithelium, Hyperplasia	0	10** (1.0)	10** (1.0)	9** (1.3)
Histiocytic Infiltrate	0	0	0	4* (1.0)
Day 13				
Number Examined Microscopically	10	10	10	10
Alveolar Epithelium, Hyperplasia	0	10** (1.3)	10** (2.0)	10** (2.0)
Bronchiole Epithelium, Hyperplasia	0	10** (1.3)	10** (1.9)	10** (1.6)
Histiocytic Infiltrate	0	1 (1.0)	10** (1.0)	10** (1.1)
Inflammation	0	8** (1.0)	10** (2.0)	10** (2.1)

* Significantly different ($P \leq 0.05$) from the chamber control group by the Fisher exact test

** $P \leq 0.01$

^a Number of animals with lesion

^b Average severity grade of lesions in affected animals: 1=minimal, 2=mild, 3=moderate, 4=marked

TABLE 18
Bromodeoxyuridine-Labeled Lung Nuclei in Female Mice in the 16-Day Special Study
of Vanadium Pentoxide^a

	Chamber Control	2 mg/m ³	4 mg/m ³	8 mg/m ³
n	10	10	10	10
Terminal Bronchiole				
Day 6	46.63 ± 3.18	80.66 ± 4.02	109.84 ± 3.34	125.28 ± 7.41
Day 13	44.37 ± 2.42	75.45 ± 3.67	92.59 ± 4.38	63.02 ± 3.22
Alveoli/Alveolar Duct Areas				
Day 6	0.63 ± 0.05	0.46 ± 0.02	0.43 ± 0.02	0.87 ± 0.06
Day 13	0.49 ± 0.03	1.15 ± 0.05	2.01 ± 0.10	2.32 ± 0.08

^a Data are given as the number of bromodeoxyuridine-labeled nuclei/mm basement membrane (mean ± standard error).

2-YEAR STUDY

Survival

Estimates of 2-year survival probabilities for male and female mice are shown in Table 19 and in the Kaplan-Meier survival curves (Figure 8). Survival of males exposed to 4 mg/m³ was significantly less than that of the chamber controls.

Body Weights and Clinical Findings

Mean body weights of males exposed to 4 mg/m³ and all exposed groups of females were generally less than those of the chamber controls throughout the study, and mean body weights of males exposed to 2 mg/m³ were less from week 85 to the end of the study (Figure 9; Tables 20 and 21). Many animals exposed to vanadium pentoxide were thin, and abnormal breathing was observed in some animals, particularly those exposed to 2 or 4 mg/m³ vanadium pentoxide.

TABLE 19
Survival of Mice in the 2-Year Inhalation Study of Vanadium Pentoxide

	Chamber Control	1 mg/m ³	2 mg/m ³	4 mg/m ³
Male				
Animals initially in study	50	50	50	50
Moribund	7	11	13	20
Natural deaths	4	6	1	3
Animals surviving to study termination	39	33	36	27
Percent probability of survival at end of study ^a	78	66	72	54
Mean survival (days) ^b	710	692	704	668
Survival analysis ^c	P=0.012	P=0.242	P=0.628	P=0.011
Female				
Animals initially in study	50	50	50	50
Accidental deaths ^d	0	3	2	0
Moribund	8	10	14	16
Natural deaths	4	5	4	2
Animals surviving to study termination	38	32	30 ^e	32
Percent probability of survival at end of study	76	68	63	64
Mean survival (days)	692	655	653	688
Survival analysis	P=0.257	P=0.475	P=0.192	P=0.270

^a Kaplan-Meier determinations

^b Mean of all deaths (uncensored, censored, and terminal sacrifice)

^c The result of the life table trend test (Tarone, 1975) is in the chamber control column, and the results of the life table pairwise comparisons (Cox, 1972) with the chamber controls are in the exposed group columns.

^d Censored from survival analyses

^e Includes one animal that died during the last week of the study

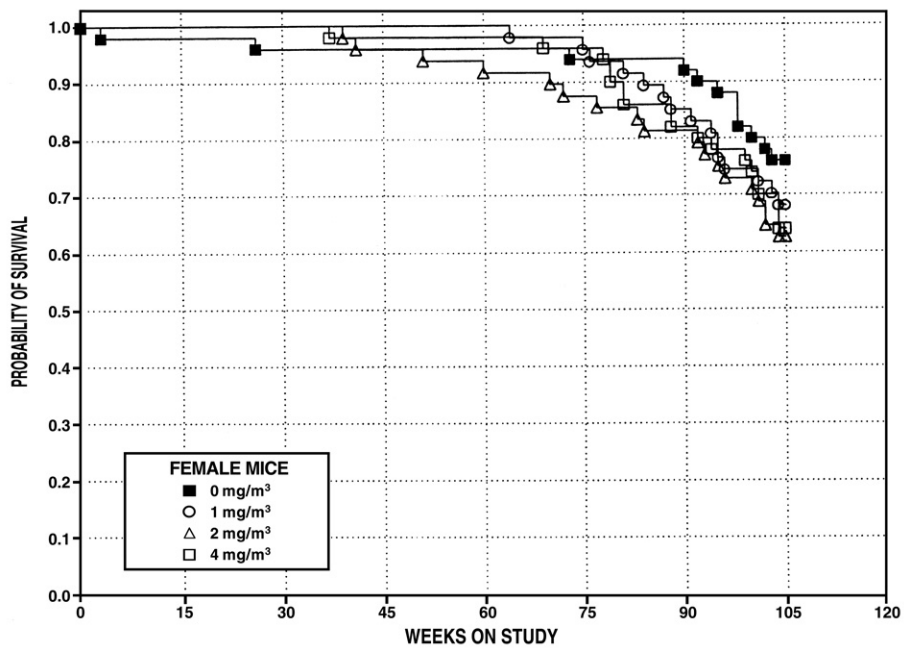
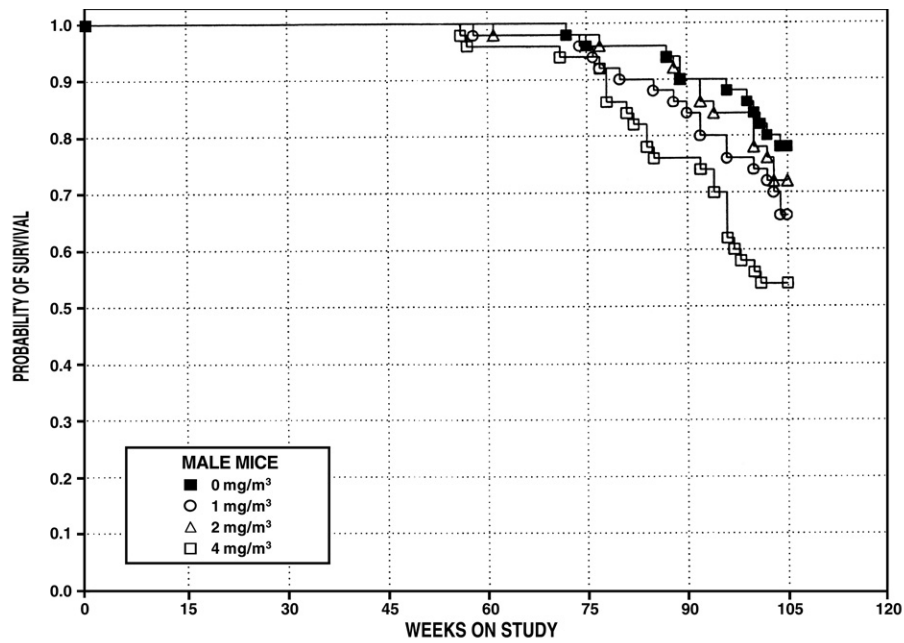

FIGURE 8
Kaplan-Meier Survival Curves for Male and Female Mice Exposed to Vanadium Pentoxide by Inhalation for 2 Years

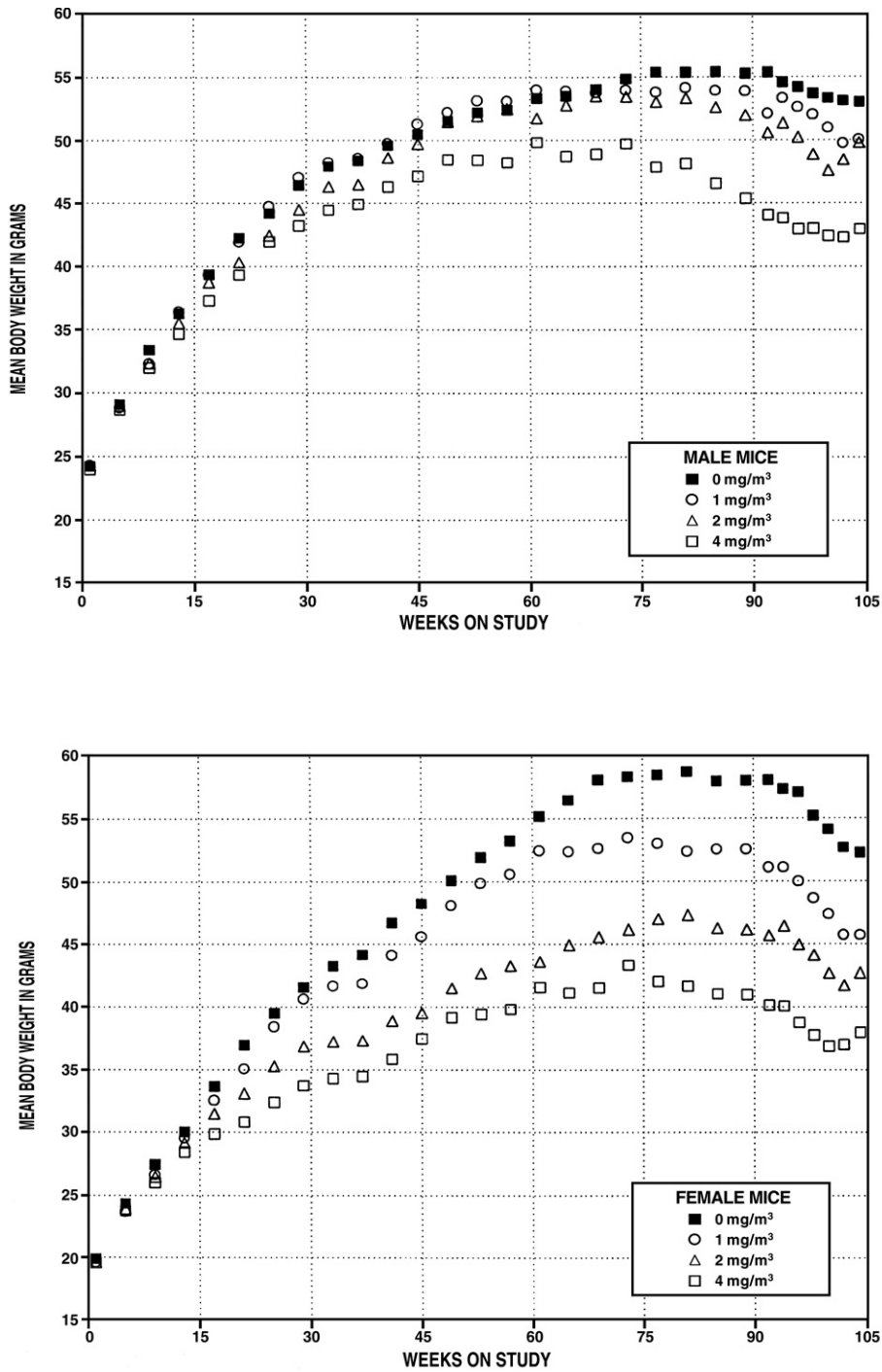

FIGURE 9
Growth Curves for Male and Female Mice Exposed to Vanadium Pentoxide by Inhalation for 2 Years

TABLE 20
Mean Body Weights and Survival of Male Mice in the 2-Year Inhalation Study of Vanadium Pentoxide

Weeks on Study	Chamber Control		1 mg/m ³			2 mg/m ³			4 mg/m ³		
	Av. Wt. (g)	No. of Survivors	Av. Wt. (g)	Wt. (% of controls)	No. of Survivors	Av. Wt. (g)	Wt. (% of controls)	No. of Survivors	Av. Wt. (g)	Wt. (% of controls)	No. of Survivors
1	24.2	50	24.4	101	50	24.3	100	50	24.0	99	50
5	29.1	50	28.9	99	50	29.0	100	50	28.7	99	50
9	33.4	50	32.3	97	50	32.4	97	50	32.0	96	50
13	36.3	50	36.4	100	50	35.5	98	50	34.6	95	50
17	39.3	50	39.3	100	50	38.7	99	50	37.3	95	50
21	42.3	50	41.9	99	50	40.3	95	50	39.3	93	50
25	44.2	50	44.8	101	50	42.5	96	50	42.0	95	50
29	46.4	50	47.1	102	50	44.5	96	50	43.2	93	50
33	47.9	50	48.2	101	50	46.3	97	50	44.5	93	50
37	48.4	50	48.6	100	50	46.5	96	50	44.9	93	50
41	49.6	50	49.8	100	50	48.6	98	50	46.3	93	50
45	50.5	50	51.3	102	50	49.7	98	50	47.2	94	50
49	51.6	50	52.3	101	50	51.5	100	50	48.5	94	50
53	52.2	50	53.2	102	50	52.0	100	50	48.4	93	50
57	52.4	50	53.2	102	50	52.5	100	50	48.2	92	49
61	53.4	50	54.1	101	49	51.8	97	50	49.8	93	48
65	53.6	50	53.9	101	49	52.8	99	49	48.7	91	48
69	54.0	50	53.8	100	49	53.5	99	49	48.9	91	48
73	54.9	49	54.0	98	49	53.5	97	49	49.7	91	47
77	55.4	48	53.8	97	46	53.1	96	48	47.9	87	45
81	55.4	48	54.2	98	45	53.4	96	48	48.1	87	43
85	55.4	48	54.0	98	45	52.6	95	48	46.6	84	39
89	55.3	47	53.9	98	43	52.0	94	45	45.4	82	38
92	55.4	45	52.1	94	42	50.6	91	45	44.1	80	38
94	54.6	45	53.4	98	40	51.4	94	43	43.8	80	37
96	54.2	45	52.7	97	39	50.2	93	42	43.0	79	35
98	53.7	44	52.1	97	38	48.9	91	42	43.0	80	30
100	53.4	43	51.0	96	38	47.6	89	42	42.4	79	29
102	53.1	41	49.8	94	37	48.4	91	39	42.3	80	27
104	53.0	40	50.1	95	34	49.8	94	36	43.0	81	27
Mean for weeks											
1-13	30.8		30.5	99		30.3	98		29.8	97	
14-52	46.7		47.0	101		45.4	97		43.7	94	
53-104	54.1		52.9	98		51.4	95		46.1	85	

TABLE 21
Mean Body Weights and Survival of Female Mice in the 2-Year Inhalation Study of Vanadium Pentoxide

Weeks on Study	Chamber Control		1 mg/m ³			2 mg/m ³			4 mg/m ³		
	Av. Wt. (g)	No. of Survivors	Av. Wt. (g)	Wt. (% of controls)	No. of Survivors	Av. Wt. (g)	Wt. (% of controls)	No. of Survivors	Av. Wt. (g)	Wt. (% of controls)	No. of Survivors
1	19.9	50	19.6	99	50	19.6	99	50	19.6	99	50
5	24.4	49	23.7	97	47	23.9	98	50	23.8	98	50
9	27.5	49	26.7	97	47	26.5	96	50	26.0	95	50
13	30.0	49	29.6	99	47	29.2	97	50	28.4	95	50
17	33.7	49	32.6	97	47	31.5	94	50	29.9	89	50
21	37.0	49	35.1	95	47	33.1	90	50	30.8	83	50
25	39.5	49	38.4	97	47	35.3	89	50	32.4	82	50
29	41.6	48	40.6	98	47	36.9	89	50	33.7	81	50
33	43.3	48	41.7	96	47	37.2	86	50	34.3	79	50
37	44.2	48	41.9	95	47	37.3	84	49	34.5	78	50
41	46.7	48	44.1	94	47	38.9	83	47	35.8	77	49
45	48.3	48	45.7	95	47	39.5	82	47	37.5	78	49
49	50.1	48	48.1	96	47	41.5	83	46	39.2	78	49
53	51.9	48	49.9	96	47	42.7	82	45	39.4	76	49
57	53.3	48	50.6	95	47	43.3	81	45	39.8	75	49
61	55.2	48	52.5	95	47	43.6	79	44	41.6	75	49
65	56.5	48	52.4	93	46	45.0	80	44	41.1	73	49
69	58.1	48	52.6	91	46	45.6	79	44	41.5	71	49
73	58.4	47	53.5	92	46	46.2	79	42	43.3	74	48
77	58.5	47	53.0	91	44	47.0	80	41	42.1	72	48
81	58.7	47	52.4	89	44	47.3	81	41	41.7	71	45
85	58.0	47	52.6	91	42	46.3	80	39	41.1	71	43
89	58.0	47	52.6	91	40	46.2	80	39	41.0	71	41
92	58.1	46	51.1	88	39	45.7	79	39	40.2	69	41
94	57.3	45	51.1	89	39	46.4	81	37	40.1	70	40
96	57.1	44	50.0	88	36	45.0	79	35	38.8	68	39
98	55.2	44	48.7	88	35	44.1	80	35	37.8	69	39
100	54.1	41	47.4	88	35	42.7	79	35	36.9	68	38
102	52.7	40	45.8	87	34	41.7	79	33	37.0	70	35
104	52.3	38	45.8	88	33	42.7	82	31	38.0	73	35
Mean for weeks											
1-13	25.5		24.9	98		24.8	97		24.5	96	
14-52	42.7		40.9	96		36.8	86		34.2	80	
53-104	56.1		50.7	90		44.8	80		40.1	71	

Pathology and Statistical Analyses

This section describes the statistically significant or biologically noteworthy changes in the incidences of neoplasms and/or nonneoplastic lesions of the lung, larynx, nose, bronchial lymph node, spleen, harderian gland, and liver. Summaries of the incidences of neoplasms and nonneoplastic lesions, individual animal tumor diagnoses, statistical analyses of primary neoplasms that occurred with an incidence of at least 5% in at least one animal group, and historical incidences for the neoplasms mentioned in this section are presented in Appendix C for male mice and Appendix D for female mice.

Lung: The incidences of alveolar/bronchiolar carcinoma and alveolar/bronchiolar adenoma or carcinoma (combined) were significantly increased in all groups of exposed male and female mice (Tables 22, C3, and D3). The incidences of alveolar/bronchiolar adenoma were significantly increased in males exposed to 2 mg/m³ and in all groups of exposed females. These increased incidences exceeded the historical ranges for controls (all routes) given NTP-2000 diet and for chamber controls given NIH-07 diet (inhalation studies) (Tables C4a and D4), and many exposed animals had multiple adenomas and/or carcinomas. Focal hyperplasia of the alveolar/bronchiolar epithelium, which is thought to be a precursor to adenoma, was not recognized in this study, possibly because of the overwhelming incidences of neoplasms and the bronchiolization described below.

Alveolar/bronchiolar adenomas, typical of those that occur spontaneously in mice, generally were distinct masses that often compressed surrounding tissue (Plate 12). Component epithelial cells were often uniform and arranged in acinar and/or irregular papillary structures and occasionally in a solid cellular pattern (Plate 13). Alveolar/bronchiolar carcinomas had similar cellular patterns but were generally larger, often exceeding 1 cm in diameter (Plate 14). Carcinomas had one or more of the following histologic features: heterogeneous growth pattern, cellular pleomorphism and/or atypia, and local invasion or metastasis (Plate 15); a number of exposed males and females had multiple alveolar/bronchiolar neoplasms (Plate 16). Microscopically, it was not usually possible to determine if the multiple neoplasms represented intrapulmonary metastases or if they were multiple independent neoplasms.

There were significantly increased incidences of alveolar epithelial hyperplasia and bronchiolar epithelial hyperplasia in the lungs of exposed male and female mice (Tables 22, C5, and D5). The hyperplasia was

essentially a diffuse change with proliferation of epithelium in the distal terminal bronchioles and immediately associated alveolar ducts and alveoli. Normally flattened epithelium was replaced with cuboidal epithelium. The hyperplasia of the alveolar epithelium was pronounced and increased in severity with increasing exposure concentration, while the hyperplasia of the distal bronchioles was minimal to mild with slight increases in severity in mice exposed to 4 mg/m³. The changes in mice were similar to those observed in rats but were not as pronounced.

Incidences of chronic inflammation and histiocytic cellular infiltrate were significantly increased in exposed groups of mice, and the incidences of interstitial fibrosis were increased in mice exposed to 2 or 4 mg/m³. The inflammatory lesions were primarily minimal to mild and consisted of interstitial, perivascular, and peribronchiolar infiltrates of mostly mononuclear inflammatory cells (mostly lymphocytes) that were occasionally present within alveoli. The most prominent histiocytic infiltrate occurred within alveoli in close proximity to alveolar/bronchiolar neoplasms, particularly carcinomas. In some instances, the foamy macrophages filled adjacent alveoli. Additionally, minimal numbers of histiocytes were observed in areas of alveolar and bronchiolar epithelial hyperplasia and appeared to be a primary exposure effect. Ideally, these two histiocytic changes would have been separated diagnostically; however, this was not possible because the change associated with bronchiolization was subtle and because neoplasms were prevalent in exposed animals. Alveolar septa were occasionally thickened by thin strands of eosinophilic fibrillar material (fibrosis). This change was most notable in areas of intense histiocytic cell infiltrate secondary to neoplasms.

The left lung lobe from female mice designated for tissue burden studies was evaluated histologically (data not reported). Lung lesions were identified early, and as expected, were more severe in females exposed to higher concentrations and progressed with time. Minimal bronchiolar epithelial hyperplasia and interstitial inflammation were initially observed in the 4 mg/m³ group on day 5. Bronchiolar epithelial hyperplasia was characterized by slight piling up of cells, some nuclear pleomorphism, and occasional karyorrhectic cells. On day 12, exposure-related lesions were evident in 2 mg/m³ females, while alveolar epithelial hyperplasia was more prominent in the 4 mg/m³ group. Lesions were first observed in the 1 mg/m³ group on day 54, and lesion severities in the 2 and 4 mg/m³ groups appeared to be increased on day 54. On day 362, lesion severity in

TABLE 22
Incidences of Neoplasms and Nonneoplastic Lesions of the Respiratory System
and Bronchial Lymph Node in Mice in the 2-Year Inhalation Study of Vanadium Pentoxide

	Chamber Control	1 mg/m ³	2 mg/m ³	4 mg/m ³
Male				
Lung ^a	50	50	50	50
Alveolar Epithelium, Hyperplasia ^b	3 (3.0) ^c	41** (2.2)	49** (3.3)	50** (3.9)
Bronchiole, Epithelium, Hyperplasia	0	15** (1.0)	37** (1.1)	46** (1.7)
Inflammation, Chronic	6 (1.5)	42** (1.5)	45** (1.6)	47** (2.0)
Alveolus, Infiltration Cellular, Histiocyte	10 (2.4)	36** (2.4)	45** (2.6)	49** (3.0)
Interstitial, Fibrosis	1 (1.0)	6 (1.7)	9** (1.2)	12** (1.7)
Alveolar/bronchiolar Adenoma, Multiple	1	1	11**	5
Alveolar/bronchiolar Adenoma (includes multiple) ^d				
Overall rate ^e	13/50 (26%)	16/50 (32%)	26/50 (52%)	15/50 (30%)
Adjusted rate ^f	27.0%	34.8%	55.9%	35.4%
Terminal rate ^g	6/39 (15%)	11/33 (33%)	24/36 (67%)	10/27 (37%)
First incidence (days)	620	405	611	562
Poly-3 test ^h	P=0.143	P=0.276	P=0.003	P=0.263
Alveolar/bronchiolar Carcinoma, Multiple	1	10**	16**	13**
Alveolar/bronchiolar Carcinoma (includes multiple) ⁱ				
Overall rate	12/50 (24%)	29/50 (58%)	30/50 (60%)	35/50 (70%)
Adjusted rate	25.5%	60.3%	62.3%	72.8%
Terminal rate	11/39 (28%)	17/33 (52%)	21/36 (58%)	15/27 (56%)
First incidence (days)	667	530	534	394
Poly-3 test	P<0.001	P<0.001	P<0.001	P<0.001
Alveolar/bronchiolar Adenoma or Carcinoma ^j				
Overall rate	22/50 (44%)	42/50 (84%)	43/50 (86%)	43/50 (86%)
Adjusted rate	45.7%	84.6%	88.1%	88.5%
Terminal rate	15/39 (39%)	26/33 (79%)	32/36 (89%)	22/27 (82%)
First incidence (days)	620	405	534	394
Poly-3 test	P<0.001	P<0.001	P<0.001	P<0.001
Larynx	49	50	48	50
Respiratory Epithelium, Epiglottis, Metaplasia, Squamous	2 (1.0)	45** (1.0)	41** (1.0)	41** (1.0)
Nose	50	50	50	50
Inflammation, Suppurative	16 (1.3)	11 (1.4)	32** (1.2)	23* (1.3)
Olfactory Epithelium, Atrophy	6 (1.0)	7 (1.6)	9 (1.3)	12 (1.2)
Olfactory Epithelium, Degeneration, Hyaline	1 (1.0)	7* (1.0)	23** (1.1)	30** (1.2)
Respiratory Epithelium, Degeneration, Hyaline	8 (1.1)	22** (1.0)	38** (1.2)	41** (1.4)
Respiratory Epithelium, Metaplasia, Squamous	0	6* (1.2)	6* (1.3)	2 (1.5)
Lymph Node, Bronchial	40	38	36	40
Hyperplasia	7 (2.1)	7 (2.4)	12 (2.1)	13 (2.2)

TABLE 22
Incidences of Neoplasms and Nonneoplastic Lesions of the Respiratory System
and Bronchial Lymph Node in Mice in the 2-Year Inhalation Study of Vanadium Pentoxide

	Chamber Control	1 mg/m ³	2 mg/m ³	4 mg/m ³
Female				
Lung	50	50	50	50
Alveolar Epithelium, Hyperplasia	0	31** (1.6)	38** (2.0)	50** (3.3)
Bronchiole, Epithelium, Hyperplasia	0	12** (1.0)	34** (1.0)	48** (1.5)
Inflammation, Chronic	4 (1.0)	37** (1.3)	39** (1.8)	49** (2.0)
Alveolus, Infiltration Cellular, Histiocyte	0	34** (2.4)	35** (2.4)	45** (2.7)
Interstitial, Fibrosis	0	1 (2.0)	4* (2.5)	8** (1.5)
Alveolar/bronchiolar Adenoma, Multiple	0	3	5*	6*
Alveolar/bronchiolar Adenoma (includes multiple) ^k				
Overall rate	1/50 (2%)	17/50 (34%)	23/50 (46%)	19/50 (38%)
Adjusted rate	2.2%	38.7%	51.5%	42.2%
Terminal rate	1/38 (3%)	9/32 (28%)	13/30 (43%)	14/32 (44%)
First incidence (days)	731 (T)	530	281	478
Poly-3 test	P<0.001	P<0.001	P<0.001	P<0.001
Alveolar/bronchiolar Carcinoma, Multiple	0	9**	5*	5*
Alveolar/bronchiolar Carcinoma (includes multiple) ^l				
Overall rate	0/50 (0%)	23/50 (46%)	18/50 (36%)	22/50 (44%)
Adjusted rate	0.0%	52.3%	44.7%	47.9%
Terminal rate	0/38 (0%)	15/32 (47%)	15/30 (50%)	12/32 (38%)
First incidence (days)	— _m	522	695	542
Poly-3 test	P<0.001	P<0.001	P<0.001	P<0.001
Alveolar/bronchiolar Adenoma or Carcinoma ⁿ				
Overall rate	1/50 (2%)	32/50 (64%)	35/50 (70%)	32/50 (64%)
Adjusted rate	2.2%	70.3%	78.0%	68.1%
Terminal rate	1/38 (3%)	20/32 (63%)	23/30 (77%)	20/32 (63%)
First incidence (days)	731 (T)	522	281	478
Poly-3 test	P<0.001	P<0.001	P<0.001	P<0.001
Larynx	50	50	49	50
Respiratory Epithelium, Epiglottis, Metaplasia, Squamous	0	39** (1.0)	45** (1.0)	44** (1.1)

TABLE 22
Incidences of Neoplasms and Nonneoplastic Lesions of the Respiratory System
and Bronchial Lymph Node in Mice in the 2-Year Inhalation Study of Vanadium Pentoxide

	Chamber Control	1 mg/m ³	2 mg/m ³	4 mg/m ³
Female (continued)				
Nose	50	50	50	50
Inflammation, Suppurative	19 (1.1)	14 (1.2)	32** (1.2)	30** (1.3)
Olfactory Epithelium, Atrophy	2 (1.5)	8* (1.3)	5 (1.0)	14** (1.3)
Olfactory Epithelium, Degeneration, Hyaline	11 (1.2)	23** (1.0)	34** (1.2)	48** (1.3)
Respiratory Epithelium, Degeneration, Hyaline	35 (1.3)	39 (1.5)	46** (1.7)	50** (1.8)
Respiratory Epithelium, Metaplasia, Squamous	0	3 (1.3)	7** (1.1)	8** (1.1)
Respiratory Epithelium, Necrosis	0	0	1 (2.0)	7** (1.4)
Lymph Node, Bronchial	39	40	45	41
Hyperplasia	3 (2.0)	13** (1.8)	14** (2.3)	20** (2.3)

(T) Terminal sacrifice

* Significantly different ($P \leq 0.05$) from the chamber control group by the Poly-3 test

** $P \leq 0.01$

^a Number of animals with tissue examined microscopically

^b Number of animals with lesion

^c Average severity grade of lesions in affected animals: 1=minimal, 2=mild, 3=moderate, 4=marked

^d Historical incidence for 2-year studies with controls given NTP-2000 diet (mean \pm standard deviation): 119/659 (17.9% \pm 7.4%), range 4%-26%; with chamber controls (inhalation studies) given NIH-07 diet: 201/1,071 (19.0% \pm 8.4%), range 8%-36%

^e Number of animals with neoplasm per number of animals examined microscopically

^f Poly-3 estimated neoplasm incidence after adjustment for intercurrent mortality

^g Observed incidence at terminal kill

^h Beneath the chamber control incidence is the P value associated with the trend test. Beneath the exposed group incidence are the P values corresponding to pairwise comparisons between the chamber controls and that exposed group. The Poly-3 test accounts for differential mortality in animals that do not reach terminal sacrifice.

ⁱ Historical incidence for NTP-2000 diet: 68/659 (10.7% \pm 5.3%), range 4%-24%; for NIH-07 diet: 97/1,071 (9.0% \pm 5.2%), range 0%-21%

^j Historical incidence for NTP-2000 diet: 176/659 (27.1% \pm 9.3%), range 12%-44%; for NIH-07 diet: 285/1,071 (26.8% \pm 8.3%), range 14%-42%

^k Historical incidence for NTP-2000 diet: 37/654 (5.4% \pm 4.0%), range 0%-12%; for NIH-07 diet: 67/1,075 (6.3% \pm 3.7%), range 0%-14%

^l Historical incidence for NTP-2000 diet: 17/654 (2.3% \pm 2.0%), range 0%-6%; for NIH-07 diet: 43/1,075 (3.9% \pm 3.2%), range 0%-12%

^m Not applicable; no neoplasms in animal group

ⁿ Historical incidence for NTP-2000 diet: 53/654 (7.6% \pm 4.7%), range 0%-12%; for NIH-07 diet: 109/1,075 (10.1% \pm 3.6%), range 4%-16%

lungs of females exposed to 4 mg/m³ was noticeably increased, and bronchiolar hyperplasia included more nuclear pleomorphism. On day 535, mice exposed to 2 mg/m³ had hyperplastic alveolar epithelial lesions and, similar to females exposed to 4 mg/m³, the hyperplasia was oriented around the terminal bronchiolar/alveolar duct. Also on day 535, lung nodules/masses were observed. While some were confirmed as neoplasms, many were in the right lung lobe and thus were not confirmed histopathologically. Similar lesions, although more severe, were observed in the core group of animals at 2 years.

Larynx: There were significantly increased incidences of minimal squamous metaplasia of the respiratory epithelium of the epiglottis in exposed groups (Tables 22, C5, and D5). Squamous metaplasia was diagnosed when the ciliated cells were replaced by one to three layers of flattened squamous epithelium. This change commonly occurs in mice in NTP inhalation studies and represents a common response to laryngeal injury.

Nose: There were increased incidences of minimal to mild suppurative inflammation of the nose in males and females exposed to 2 or 4 mg/m³ (Tables 22, C5, and D5). The inflammation consisted of focal aggregates of few to moderate numbers of neutrophils generally subjacent to the epithelium of the turbinates, septum, or lateral wall of the anterior nose. In the more severe cases (predominantly in females exposed to 4 mg/m³), a short segment of the overlying epithelium was ulcerated (necrosis). Similarly, in some males and females, the overlying respiratory epithelium was replaced by one or more layers of flattened epithelium (squamous metaplasia), and the incidences were marginally increased in some exposed groups of mice.

The majority of the olfactory epithelium covers the turbinates in the distal portion of the nose. There were marginal but significant increases in the incidences of atrophy of this epithelium in females exposed to 1 or 4 mg/m³, and the incidences in exposed males, though not significant, occurred with a positive trend (Tables 22, C5, and D5). The normally thick layers of epithelium were minimally thinned due to loss of olfactory epithelium. In some cases, there was replacement of the lost epithelium by respiratory epithelium. The incidences of hyaline degeneration of the olfactory and respiratory epithelium of the nose were increased in exposed mice. Affected epithelial cells contained eosinophilic material within the cytoplasm. Hyaline

degeneration of nasal epithelium occurs with a high and variable spontaneous rate in aged B6C3F₁ mice and may involve the respiratory and/or olfactory epithelium. The incidence and severity frequently increase with exposure to inhaled toxicants, but this lesion is not considered an important biological effect.

Bronchial Lymph Node: There were significant increases in the incidences of hyperplasia of the bronchial lymph node in exposed groups of females, and while not significant, a positive trend in the incidences of this lesion also occurred in males (Tables 22, C5, and D5). Hyperplasia was characterized by diffuse enlargement (up to 3×) due to expanded numbers of normal-appearing lymphocytes. This response was considered secondary to the inflammation and/or neoplasms of the lung.

Spleen: There was a positive trend in the incidences of hemangiosarcoma of the spleen in male mice (chamber control, 0/50; 1 mg/m³, 0/50; 2 mg/m³, 0/50; 4 mg/m³, 3/50; Table C3). However, the incidence in the 4 mg/m³ group was within the historical range in controls (all routes) given NTP-2000 diet [13/657 (2.1% ± 1.8%), range 0%-6%]. In addition, the incidences of hemangioma or hemangiosarcoma (combined) in all organs were not significant (1/50, 2/50, 2/50, 3/50). The marginal increase in the incidence of hemangiosarcoma of the spleen was not considered related to vanadium pentoxide exposure.

Other Organs: There was a significant decrease in the incidence of harderian gland adenoma in male mice exposed to 4 mg/m³ (Tables 23 and C3); however, the incidence of harderian gland adenoma or carcinoma (combined) in this group was not statistically significant. Negative trends in the incidences of hepatocellular adenoma and hepatocellular adenoma or carcinoma (combined) occurred in males (Tables 23 and C3). The incidences of harderian gland and hepatocellular neoplasms in exposed groups were within the historical ranges in controls given NTP-2000 diet or inhalation chamber controls given NIH-07 diet (Tables C4b and C4c). It has been shown that in NTP studies, the incidence of hepatocellular neoplasms decreases with decreases in body weight (Haseman *et al.*, 1997). The mean body weight and survival of males exposed to 4 mg/m³ were decreased and may have contributed to these decreased incidences of harderian gland and liver neoplasms; the decreases were not considered to be exposure related.

TABLE 23
Incidences of Harderian Gland and Liver Neoplasms in Male Mice in the 2-Year Inhalation Study of Vanadium Pentoxide

	Chamber Control	1 mg/m ³	2 mg/m ³	4 mg/m ³
Harderian Gland ^a	50	50	50	50
Adenoma (includes bilateral) ^{b,c}	8	5	4	1*
Adenoma or Carcinoma ^d	8	5	5	2
Liver	50	50	50	50
Hepatocellular Adenoma ^e	15	17	10	7
Hepatocellular Carcinoma	14	18	14	12
Hepatocellular Adenoma or Carcinoma ^f				
Overall rate ^g	26/50 (52%)	30/50 (60%)	22/50 (44%)	17/50 (34%)
Adjusted rate ^h	52.8%	63.2%	46.6%	39.2%
Terminal rate ⁱ	17/39 (44%)	22/32 (67%)	15/36 (42%)	9/27 (33%)
First incidence (days)	523	514	611	541
Poly-3 test ^j	P=0.045N	P=0.204	P=0.341N	P=0.131N

* Significantly different ($P \leq 0.05$) from the chamber control group by the Poly-3 test

^a Number of animals necropsied (harderian gland) or number of animals with organ examined microscopically (liver)

^b Number of animals with lesion

^c Historical incidence for 2-year studies with controls given NTP-2000 diet (mean \pm standard deviation): 53/659 (8.1% \pm 3.9%), range 2%-16%; with chamber controls (inhalation studies) given NIH-07 diet: 48/974 (4.6% \pm 4.1%), range 0%-14%

^d Historical incidence for NTP-2000 diet: 57/659 (8.8% \pm 4.1%), range 2%-16%; for NIH-07 diet: 58/974 (5.5% \pm 4.1%), range 0%-14%

^e Historical incidence for NTP-2000 diet: 195/659 (30.4% \pm 8.9%), range 12%-46%; for NIH-07 diet: 356/1,072 (33.4% \pm 9.3%), range 15%-48%

^f Historical incidence for NTP-2000 diet: 304/659 (47.8% \pm 12.9%), range 28%-72%; for NIH-07 diet: 582/1,072 (54.7% \pm 14.0%), range 22%-86%

^g Number of animals with neoplasm per number of animals examined microscopically

^h Poly-3 estimated neoplasm incidence after adjustment for intercurrent mortality

ⁱ Observed incidence at terminal kill

^j Beneath the chamber control incidence is the P value associated with the trend test. Beneath the exposed group incidence are the P values corresponding to pairwise comparisons between the chamber controls and that exposed group. The Poly-3 test accounts for differential mortality in animals that do not reach terminal sacrifice. A negative trend or a lower incidence in an exposure group is indicated by N.

Tissue Burden Analyses

Tissue burden analyses were performed on female mice exposed to 1, 2, or 4 mg/m³ on days 1, 5, 12, 26, 54, 171, 362, and 535. Lung weights from female mice increased throughout the study (Table K9). Although there appeared to be an exposure concentration-related increase in lung weights on day 12, it was primarily due to increases in lung weights of females exposed to 4 mg/m³. In general, lung weights of female mice exposed to 1 or 2 mg/m³ were similar throughout the study.

Simple visual inspection of the lung burden data indicates that lung burdens increased roughly in proportion to exposure concentration (Figure 10A; Table K9). Unlike rats, for female mice, lung burdens increased

proportionally for the majority of the time points, indicating linear toxicokinetics (Figure 10B). Departures from proportional behavior were quite small. Similarly, areas under the lung burden versus time curves increased in proportion to exposure concentration (Table K10). Thus, proportional increases with exposure concentration were clearly evident in mice.

As in the rat study, the overall assessment of vanadium pentoxide lung deposition and clearance was complicated by the fact that during the 2-year study, lung burdens in the 2 and 4 mg/m³ mouse groups did not reach a steady state. Rather, lung burdens in the 2 and 4 mg/m³ groups (5.9 and 11.3 μ g, respectively) increased early in the study, reaching a peak near day 54 and then declining until day 535 (Figure 10A). This

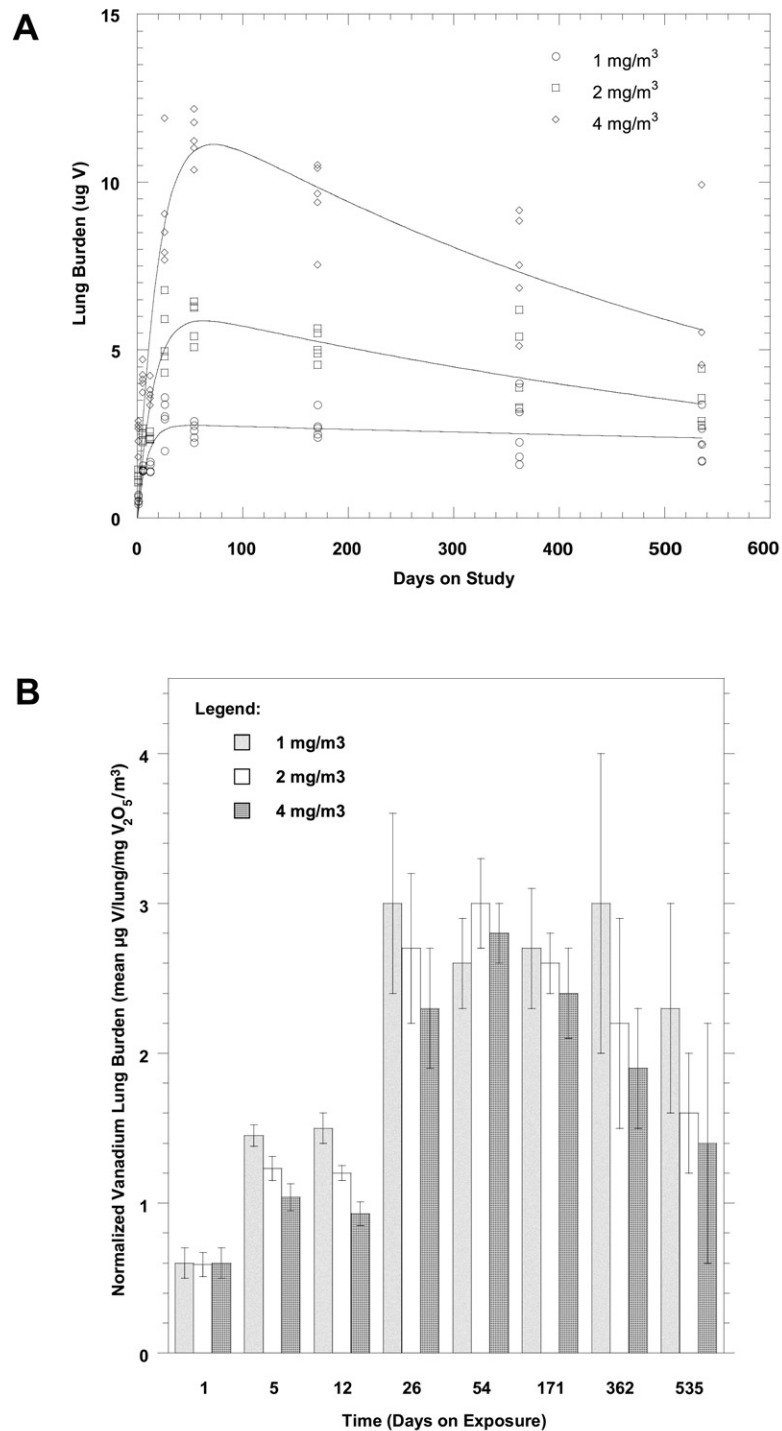

FIGURE 10
Lung Burden ($\mu\text{g V}$) (A) and Normalized Lung Burden ($\mu\text{g V/Lung per mg V}_2\text{O}_5/\text{m}^3$) (B) of Vanadium in Female Mice in the 2-Year Inhalation Study of Vanadium Pentoxide.
 Data are presented as mean \pm standard deviation. Curves represent the fit of the lung deposition and clearance model to the data.

accumulation of vanadium during this early period indicated that the elimination rate was slow relative to the deposition rate. Lung burdens in the 1 mg/m³ group increased for the first 26 days of the study, at which time they peaked (3 µg) and appeared to reach steady state. As in the rat study, attempts to fit commonly used lung burden models that assume a constant deposition rate and proportional clearance rate were unsuccessful with these data except for the 1 mg/m³ group. Therefore, the same model developed for rats was used for mice, and as in the rat study, the model fit the lung data for each exposure concentration well. Initial deposition rates that were normalized to exposure concentration were not constant and decreased slightly with exposure concentration, indicating the initial deposition rate of vanadium increased as the exposure concentration increased; this increase was less than proportional to exposure concentration. In addition, there was a clear time-dependent decline in the deposition rate in the 2 mg/m³ (0.41 to 0.22 µg/day) and 4 mg/m³ (0.62 to 0.27 µg/day) groups between days 1 and 535 which further reduced the amount of vanadium deposition with time. However, there was minimal change in the deposition rate in the 1 mg/m³ group (0.31 to 0.26 µg/day) throughout the study. As in rats, the most likely explanation for the decreased deposition rates in the 2 and 4 mg/m³ groups was a change in pulmonary function brought about by vanadium pentoxide-induced alterations in the airways and alveoli of the lung as observed in the 3-month rat study. Clearance rates were decreased as the exposure concentration was increased. Changes were more notable in the 2 and 4 mg/m³ groups compared to the 1 mg/m³ group. Clearance half-times in the 16-day special study were 2 to 3 days for the 2 and 4 mg/m³ groups (Table K8). However, the clearance half-times in the 2-year study were much longer: 6, 11, and 14 days for the 1, 2, and 4 mg/m³ groups, respectively (Table K10). Therefore, it appears that vanadium is cleared more rapidly from the lungs of mice exposed to vanadium pentoxide for short periods of time or at low concentrations repeatedly for longer periods.

Deposition rates in exposed mice (2 and 4 mg/m³ groups) decreased to a greater extent over time, while the deposition rate in the 1 mg/m³ group remained relatively constant. Since these decreases were greater in mice than in rats, it was even more important to estimate the total vanadium lung "dose" and to determine if the lung dose was proportional to exposure concentration.

With the deposition rate curve integrated over the 535 days of the study (Figure 11), the total vanadium lung dose was estimated to be 153, 162 and 225 µg vanadium for the 1, 2, and 4 mg/m³ groups, respectively. The total lung dose for each group normalized to exposure concentration was 153, 80.9, and 56.2 µg vanadium per mg/m³, indicating that the normalized lung dose was not constant. The total lung doses received by the 1 and 2 mg/m³ groups were nearly identical, and in fact, on day 362 the deposition rate for the 2 mg/m³ group was less than that of the 1 mg/m³ group. In addition, the total lung dose in the 4 mg/m³ group was only about 50% higher than that of the 1 mg/m³ group. These data indicate that for mice, the total lung dose was similar among the exposure groups. Based on the last measured lung burdens, mice appeared to retain about 2% to 3% of the total estimated lung doses on day 535.

Vanadium was detected in the blood at concentrations several orders of magnitude lower than that measured in the lung of exposed mice (Table K11). Blood vanadium concentrations in the 1 and 2 mg/m³ groups were marginally increased over that of the chamber control group. Overall, blood vanadium concentrations appeared to increase with increasing exposure concentration; however, this proportionality was less clear when the 1 and 2 mg/m³ groups were compared. Blood vanadium concentrations in the 1 and 2 mg/m³ groups appeared to peak on day 54, while concentrations in mice exposed to 4 mg/m³ peaked on day 26. The peak in blood vanadium generally compares to the time of maximum lung burden in each exposed group. Blood concentrations declined until day 171, after which they remained relatively constant until the end of the study.

GENETIC TOXICOLOGY

Vanadium pentoxide (0.03 to 333.00 µg/plate) was not mutagenic in *Salmonella typhimurium* strain TA97, TA98, TA100, TA102, or TA1535 with or without induced rat or hamster liver S9 enzymes (Table E1). No increase in the frequency of micronucleated normochromatic erythrocytes (NCEs) was seen in peripheral blood samples from male or female B6C3F₁ mice exposed to vanadium pentoxide for 3 months by inhalation (Table E2). Furthermore, chemical exposure had no effect on the ratio of polychromatic erythrocytes/NCEs in peripheral blood (data not presented), indicating no toxicity to the bone marrow by vanadium pentoxide.

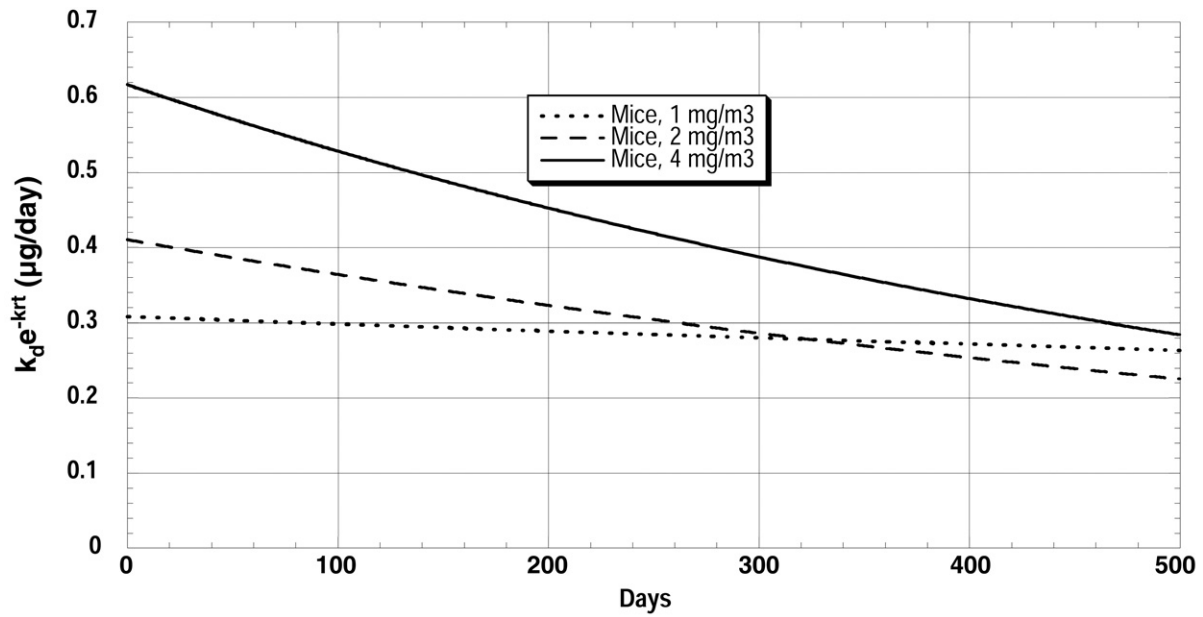

FIGURE 11
Calculated Vanadium Lung Deposition Rates in Female Mice in the 2-Year Inhalation Study of Vanadium Pentoxide.

Data are based on deposition rates determined from the model.

Vanadium Pentoxide, NTP TR 507

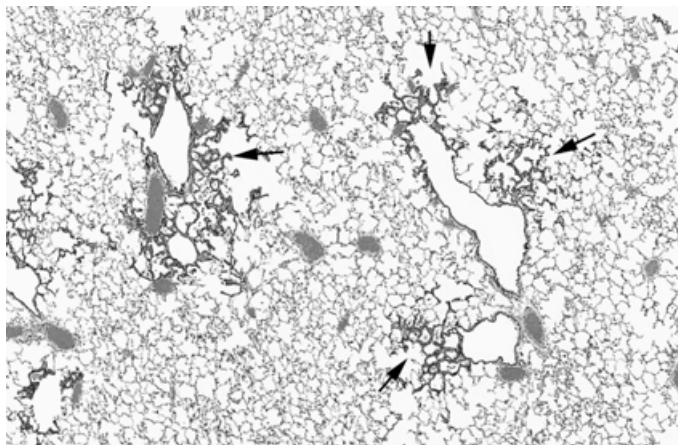

PLATE 1

Lung: Low magnification of the lung from a male F344/N rat exposed to 2 mg/m³ vanadium pentoxide in the 2-year inhalation study. Note the multifocal areas of hypercellularity (arrows) and compare to the homogeneous appearance of the normal lung in Plate 2. H&E; 25×

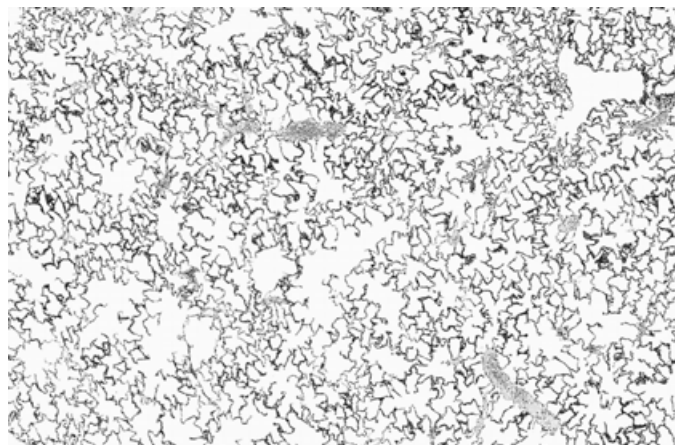

PLATE 2

Lung: Normal lung from a chamber control male F344/N rat in the 2-year vanadium pentoxide inhalation study using the same magnification as the abnormal lung in Plate 1. H&E; 25×

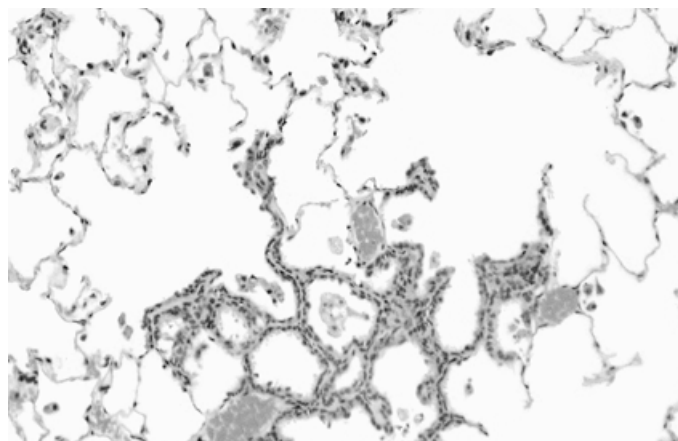

PLATE 3

Lung: Higher magnification of Plate 1. The distal airway epithelium is more prominent, and the normally flattened epithelium of the alveolar duct and alveoli is cuboidal and prominent (bronchiolization). Normal lung tissue is present peripherally. H&E; 125×

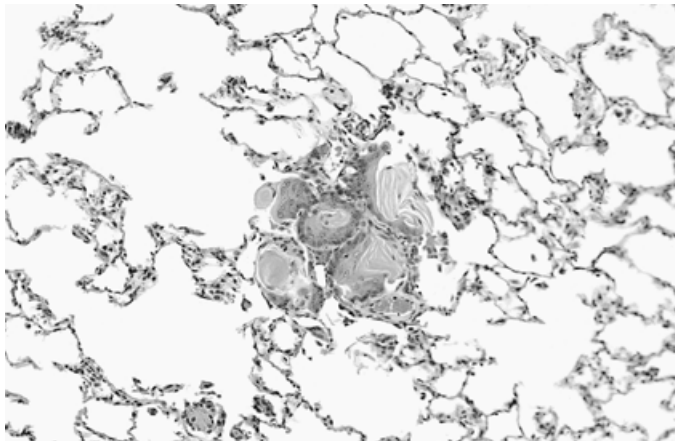

PLATE 4

Lung: Squamous metaplasia along the wall of alveoli in a male F344/N rat exposed to 2 mg/m³ vanadium pentoxide in the 2-year inhalation study. The squamous epithelium is layered with keratin production into the alveoli. H&E; 85×

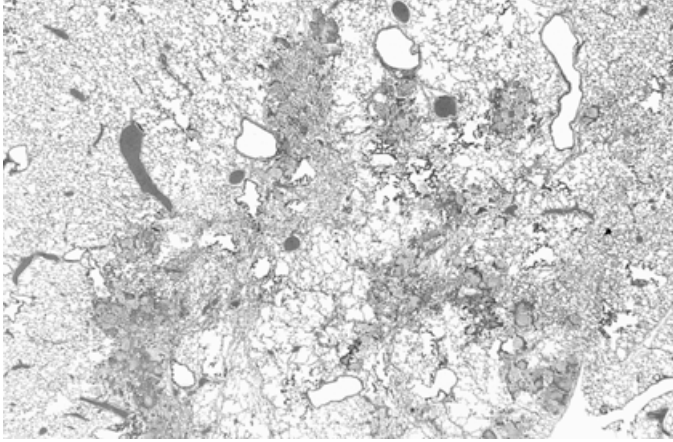

PLATE 5

Lung: Lower magnification of lungs containing much more severe areas of squamous metaplasia in two different male F344/N rats exposed to 2 mg/m³ vanadium pentoxide in the 2-year inhalation study (Plates 5 and 6). Note the focally extensive area of lung involvement in these two rats. H&E; 8x□

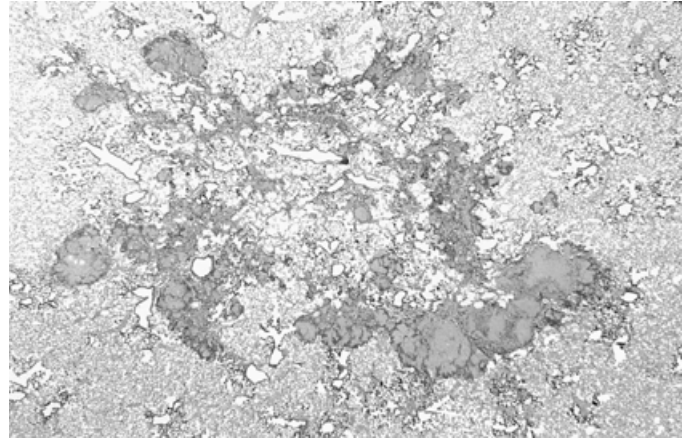

PLATE 6

Lung: H&E; 6x□

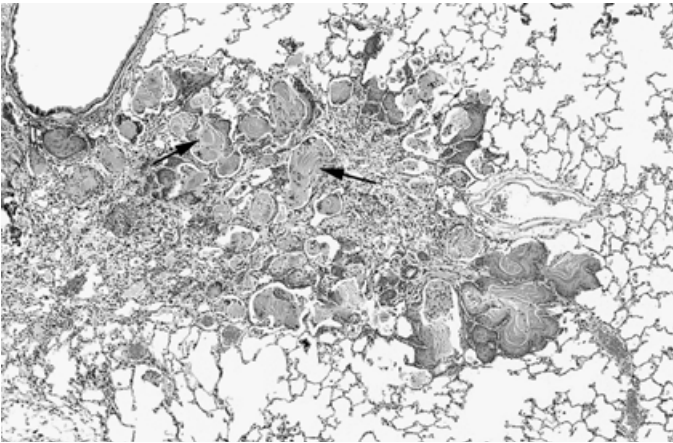

PLATE 7

Lung: Higher magnification of one area of squamous metaplasia from Plate 5. Note the florid nature of the change and the keratin production (arrows). Male F344/N rat exposed to 2 mg/m³ vanadium pentoxide in the 2-year inhalation study. H&E; 33x□

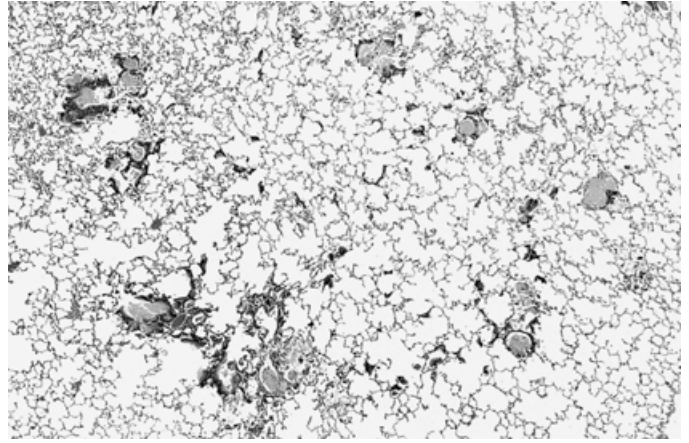

PLATE 8

Lung: Milder squamous metaplasia in a male F344/N rat exposed to 2 mg/m³ vanadium pentoxide in the 2-year inhalation study. This is a slightly higher magnification than Plates 5 and 6. Though less severe, as in Plates 5 and 6, squamous metaplasia involves a focally extensive area of the lung. H&E; 20x□

Vanadium Pentoxide, NTP TR 507

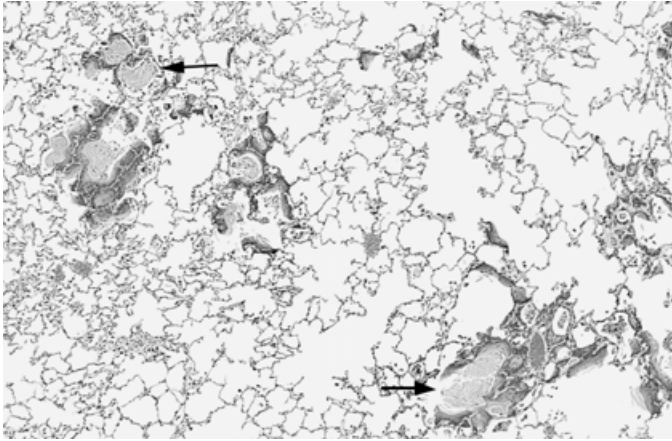

PLATE 9

Lung: Higher magnification of some of the area of squamous metaplasia from Plate 8. Note the keratin production (arrows). Male F344/N rat exposed to 2 mg/m³ vanadium pentoxide in the 2-year inhalation study. H&E; 40x□

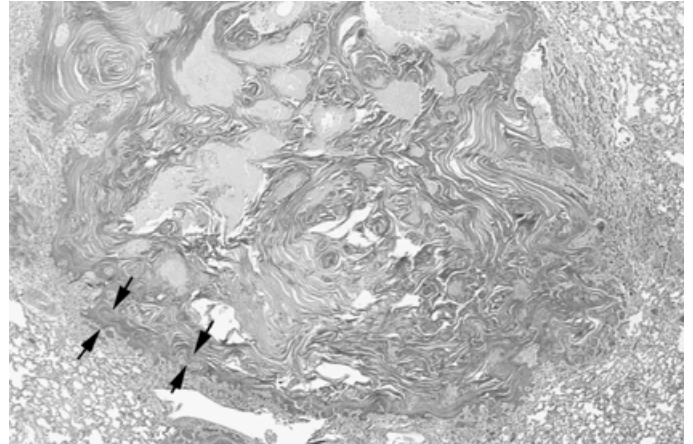

PLATE 10

Lung: Squamous cyst in the lung of a male F344/N rat exposed to 2 mg/m³ vanadium pentoxide in the 2-year inhalation study. Note the large focal lesion with a variably thick wall of squamous epithelium (arrows) and filled with keratin. H&E; 16x□

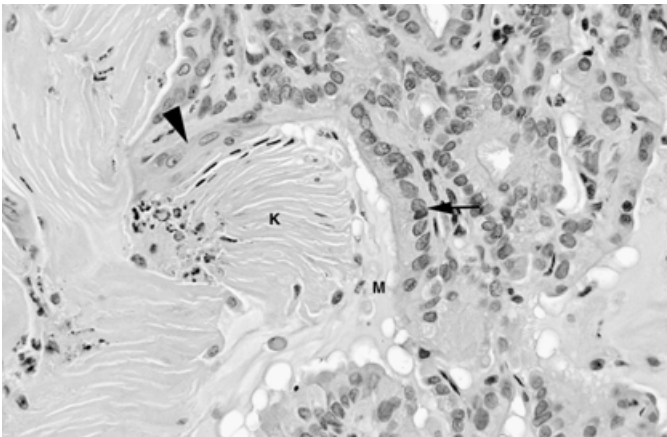

PLATE 11

Lung: Higher magnification of an area of squamous metaplasia in the lung of a male F344/N rat exposed to 2 mg/m³ vanadium pentoxide in the 2-year inhalation study. Note an alveolar structure with squamous metaplasia on one side (arrowhead) with keratin production (K) and respiratory metaplasia (arrow) on the other. In the space between the respiratory epithelium and the keratin, there is mucoid material (M). H&E; 250x□

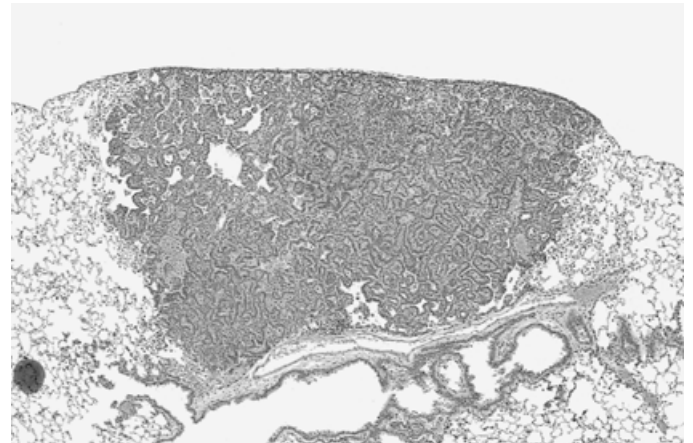

PLATE 12

Lung: Low magnification of an alveolar/bronchiolar adenoma in the lung of a male B6C3F₁ mouse exposed to 4 mg/m³ vanadium pentoxide in the 2-year inhalation study. H&E; 33x□

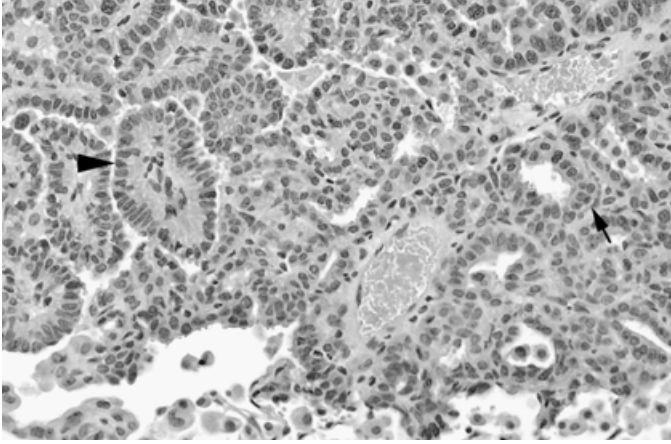

PLATE 13

Lung: Higher magnification of Plate 12 demonstrating the papillary (arrowhead) and acinar (arrow) growth pattern within the alveolar/bronchiolar adenoma in a male B6C3F₁ mouse exposed to 4 mg/m³ vanadium pentoxide in the 2-year inhalation study. H&E; 200×

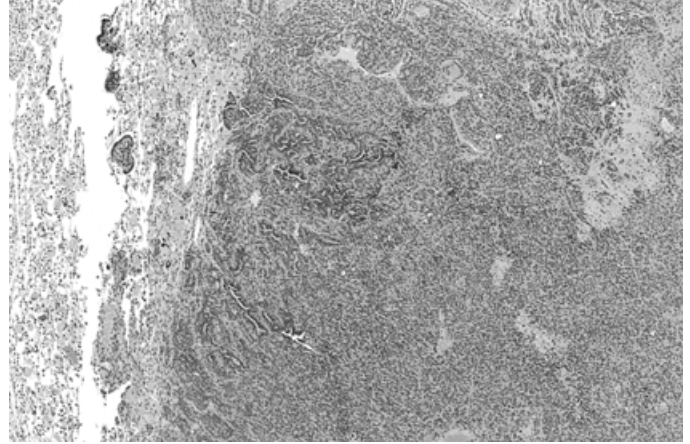

PLATE 14

Lung: An alveolar/bronchiolar carcinoma in the lung of a male B6C3F₁ mouse exposed to 4 mg/m³ vanadium pentoxide in the 2-year inhalation study. This is the same magnification as the adenoma in Plate 12. H&E; 33×

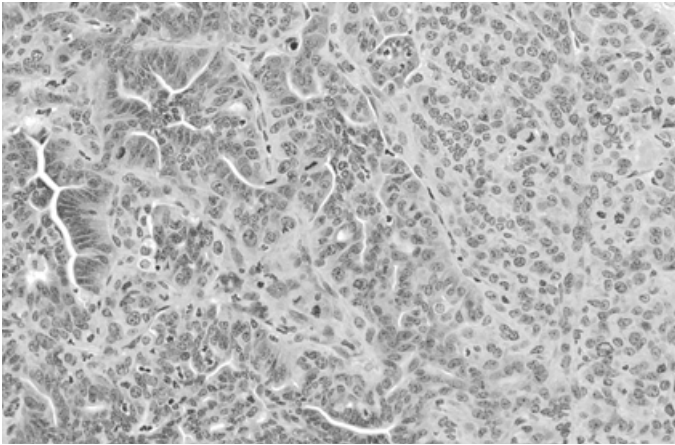

PLATE 15

Lung: Higher magnification of Plate 14, demonstrating the heterogeneous growth pattern with a solid area to the right and acinar and/or papillary structures to the left. Note the cellular pleomorphism in this alveolar/bronchiolar carcinoma. Male B6C3F₁ mouse exposed to 4 mg/m³ vanadium pentoxide in the 2-year inhalation study. H&E; 165×

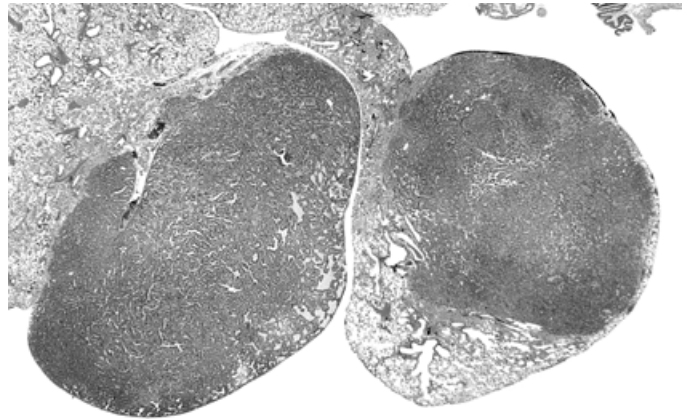

PLATE 16

Lung: Low magnification of a lung with multiple alveolar/bronchiolar carcinomas of a male B6C3F₁ mouse exposed to 4 mg/m³ vanadium pentoxide in the 2-year inhalation study. The two neoplasms in this photo appear to be in different lobes of the right lung, and this animal had alveolar/bronchiolar carcinomas in the left lung lobe as well. H&E; 6×

DISCUSSION AND CONCLUSIONS *

Occupational exposure to vanadium pentoxide occurs during the cleaning and repairing of oil-fired boilers, the handling of catalysts, and during the manufacture of vanadium and steel alloys. There is also potential for nonoccupational exposure to vanadium pentoxide from the burning of fossil fuels and from emissions from metallurgical sites. Upper and lower respiratory tract symptoms have also been associated with vanadium pentoxide exposure. Vanadium pentoxide was nominated for study because of its potential for human exposure and the lack of chronic toxicity studies. Particulate vanadium pentoxide was evaluated for toxicity and carcinogenicity in 16-day, 3-month, and 2-year whole-body inhalation studies in male and female F344/N rats and B6C3F₁ mice.

In the 16-day studies, mortality occurred in male rats and mice exposed to 32 mg/m³, and body weight deficits greater than 10% were observed in male and female rats exposed to concentrations of 16 mg/m³ or greater and in 32 mg/m³ mice. In the 3-month studies, the 16 mg/m³ concentration was lethal to several rats and one male mouse; body weights were severely reduced in rats exposed to 16 mg/m³. The respiratory tract was clearly the primary site of toxicity in rats and mice exposed to vanadium pentoxide, with rats being somewhat more severely affected than mice. The respiratory effects were more intense with increased exposure time, as indicated by increased lung weights and a greater spectrum and increased severity of proliferative and inflammatory lesions in the lungs of most exposed rats and mice in the 3-month studies.

In the 3-month studies, alveolar/bronchiolar epithelial hyperplasia was present in all mice exposed to 8 or 16 mg/m³, but occurred with greater severity and was present in all rats exposed to 2 mg/m³ or greater. The severities of pulmonary inflammation were similar between rats and mice, but the incidences of this lesion were significantly increased at lower concentrations in rats. Minimal to moderate fibrosis of the lung occurred in rats exposed to 2 mg/m³ or greater. These results are consistent with fibrotic responses induced in rats following intratracheal instillation of vanadium pentoxide

(Bonner *et al.*, 1998, 2000) and with changes in pulmonary function and inflammatory changes in the upper and lower respiratory tracts of animals exposed to vanadium pentoxide, other vanadium compounds, or reactive oil fly ash (ROFA) (Knecht *et al.*, 1985, 1992; Cohen *et al.*, 1996; Pierce *et al.*, 1996; Dreher *et al.*, 1997; Kodavanti *et al.*, 1998). The no-observed-adverse-effect level for lungs was 1 mg/m³ in rats and was not determined in mice.

Pulmonary function and lung lavage analyses were performed in 3-month study rats. Taken together, hyperplastic and inflammatory lesions, the presence of exudate in the bronchioles, and lavage fluid analysis supported conclusions from the pulmonary function tests that indicated restrictive lung disease in rats exposed to 4 mg/m³ or greater. These results are also consistent with pulmonary function changes (Zenz and Berg, 1967; Musk and Tees, 1982; Levy *et al.*, 1984) and upper airway inflammation in workers or human subjects exposed to vanadium pentoxide or fuel-oil ash containing vanadium pentoxide (Hauser *et al.*, 1995b; Woodin *et al.*, 1998).

Rat and mouse 16-day special studies were performed to determine lung and blood vanadium concentrations and lung clearance half-times of vanadium. As was expected following exposure to vanadium pentoxide, lung weights of all exposed groups of rats and mice were significantly greater than those of the chamber controls; there was little difference among exposed groups. After 8 days of recovery, lung weights of exposed rats and mice were similar to those of the chamber controls. Lung burdens and AUCs indicated lung burden proportionality and, when normalized to exposure concentration, indicated linear kinetics. Mice cleared vanadium from their lungs faster than rats based on lung clearance half-times.

In the 2-year studies, lung burden data appeared proportional to exposure concentration in rats and mice. In a typical lung burden model from particulate inhalation studies, there are assumptions that allow for a constant deposition rate and a proportional clearance rate. However, this was not the case for the mid- and

*Additional information has been added to this report that is relevant to the Discussion section. Please see the Addendum inserted after the title page. [May 9, 2022]

high-exposure concentration groups of rats and mice, and, as such, a model was developed to allow for decrease in deposition over time. Interestingly, rats removed vanadium from the lungs much slower than mice, with clearance half-times of vanadium lung burdens approximately six to nine fold longer in rats than in mice at comparable exposure concentrations. In rats and mice, lung clearance half-times were considerably longer than those observed in the 16-day special studies. Vanadium appears to be cleared more rapidly from the lungs of animals exposed to a low “dose” or short-term exposure than animals exposed to a high “dose” or repeated exposure for extended periods of time. Vanadium pentoxide and other vanadium compounds can alter alveolar macrophage integrity and function, thereby adversely affecting a vital clearance mechanism in the respiratory tract (Waters *et al.*, 1974; Schiff and Graham, 1984; Fisher *et al.*, 1986). In addition to the pathologic effects present in exposed lungs during the 2-year study, an effect on macrophage function and integrity may be a possible explanation for the difference in clearance half-times observed.

Though deposition patterns were similar between rats and mice, the maximum lung burdens occurred much later in rats (day 173) than in mice (days 26 to 54). The lung burdens appeared to reach steady state at the lowest exposure concentrations in rats (0.5 mg/m³) and mice (1 mg/m³). A decline in lung burdens was observed in both species. It is possible that the decreased deposition rates in rats exposed to 1 mg/m³ or greater and mice exposed to 2 mg/m³ or greater were due to a change in pulmonary function brought about by vanadium pentoxide-induced alterations in the airways and alveoli of the lung as was observed in the 3-month rat studies. The retention of vanadium in the lungs at 18 months was lower in mice (2% to 3%) than in rats (13% to 15%) at comparable exposure concentrations.

From the lung burden studies, the total lung “dose” was estimated for each exposure concentration to aid in interpretation of lung pathology in exposed rats and mice. The total lung doses for rats exposed to 0.5, 1, or 2 mg/m³ were estimated to be 130, 175, and 308 µg vanadium, respectively. The total lung doses for mice exposed to 1, 2, or 4 mg/m³ were 153, 162, and 225 µg vanadium, respectively. There was little difference in the total lung dose for mice, especially between the 1 and 2 mg/m³ groups.

The highest concentration (2 mg/m³) chosen for the 2-year study in rats was based on increased lung weights and increased incidences and severities of respiratory lesions in males and females exposed to 4 mg/m³ or greater. Similarly, the highest exposure concentration (4 mg/m³) selected for mice was based on reduced body weight gains of 8 and 16 mg/m³ males and females, increased lung weights of 4 mg/m³ or greater males and females, increased incidences of epithelial hyperplasia, and increased incidences and severities of inflammatory lesions of the lungs in mice exposed to 8 mg/m³ versus those exposed to 4 mg/m³.

Survival rates and body weights were not affected in rats exposed to vanadium pentoxide for 2 years. However, the survival rate of male mice exposed to 4 mg/m³ was less than that of chamber controls, and mean body weights of male mice exposed to 4 mg/m³ and all exposed groups of female mice were generally less than those of the chamber controls throughout the study. As in the 3-month studies, the respiratory tract was the primary site of toxicity in rats and mice. Continued exposure to vanadium pentoxide for 2 years caused increases in the incidences of alveolar/bronchiolar adenoma and alveolar/bronchiolar carcinoma in the lungs of male rats and male and female mice and also induced respiratory tract proliferative and inflammatory lesions in rats and mice.

For male rats exposed to 0.5 or 2 mg/m³ for 2 years, the incidences of alveolar/bronchiolar adenoma, carcinoma, and adenoma or carcinoma (combined) were at or above the historical control range for male rats fed NTP-2000 diet (all routes) or NIH-07 diet (inhalation). Three male rats exposed to 0.5 or 2 mg/m³ and one male rat exposed to 1 mg/m³ developed alveolar/bronchiolar carcinomas, one of which metastasized. In addition, there were no carcinomas in the chamber control rats. Alveolar/bronchiolar adenomas and especially carcinomas and metastases from the site of origin are uncommon in rats (Hahn, 1993). In male rats fed the NTP-2000 diet, only 2 of 609 control rats developed alveolar/bronchiolar carcinomas, and there was never more than one of this neoplasm in a study. The neoplastic response in male rats exposed to 1 mg/m³ was just within the historical control ranges for male rats fed NTP-2000 diet (all routes) or NIH-07 diet (inhalation). Because of the increased incidences of alveolar/bronchiolar adenoma, alveolar/bronchiolar carcinoma, and alveolar/bronchiolar adenoma or carcinoma

(combined) in the 0.5 and 2 mg/m³ groups and the rarity of these neoplasms in rats, this response was considered to be related to exposure to vanadium pentoxide.

In female rats, the incidence of alveolar/bronchiolar adenoma in the 0.5 mg/m³ group exceeded the historical control range for female rats fed NIH-07 diet (inhalation) and was just within the range for studies using the NTP-2000 diet (all routes). One female exposed to 2 mg/m³ had an alveolar/bronchiolar carcinoma; the incidence in the 2 mg/m³ group was at the upper end of the historical ranges for studies using the NTP-2000 diet (all routes) or the NIH-07 diet (inhalation). Because alveolar/bronchiolar adenomas and carcinomas are rare, especially in female rats (Hahn, 1993), and were not present in chamber controls, it is possible that the response was related to vanadium pentoxide exposure. However, because this was primarily a low concentration adenoma effect and the overall neoplastic response in female rats was within the historical control ranges and did not achieve statistical significance, a clear relationship between lung neoplasms and vanadium pentoxide exposure could not be determined.

In the 2-year studies, vanadium pentoxide exposure caused a more pronounced neoplastic response in mice than in rats. The incidences of alveolar/bronchiolar adenoma, carcinoma, and adenoma or carcinoma (combined) were increased in male and female mice and exceeded the historical control ranges at all exposure concentrations. As in rats, the neoplasms in mice were morphologically similar to those that occur spontaneously. However, many of the exposed mice had multiple alveolar/bronchiolar neoplasms, an uncommon response in mice, and in some cases it was difficult to distinguish between multiplicity and metastases from other lung neoplasms. Mice generally are not considered to be responsive to particulate exposure for the development of lung neoplasms, even at high concentrations. In NTP particulate inhalation studies, gallium arsenide, nickel oxide, talc, and nickel subsulfide were negative for carcinogenicity in the lung of mice (except nickel oxide which was equivocal in female mice), but were positive in rats (NTP, 1993b, 1996a,b, 2000). However, clear evidence of carcinogenicity has been observed in male and female mice exposed to insoluble and soluble aerosols such as indium phosphide, molybdenum trioxide, and cobalt sulfate heptahydrate (NTP 1997, 1998, 2001). In the present study, a clear neoplastic response was observed in the lungs of male and female mice.

Several dose metrics were considered in interpretation of the 2-year lung burden studies in rats and mice (Appendix K). In the case of all dose metrics, rats received more vanadium than mice. The total “dose” in the 2-year lung burden studies was estimated to aid in interpretation of lung pathology in exposed rats and mice. In mice, the total “dose” was similar in the two lowest exposure groups and may help explain the flat “dose response” in the lung neoplasm response in male and female mice. Also, in rats, the total lung dose was quite similar for the two lower exposure concentrations. Considering that there are typically no sex-related differences in lung deposition, the total lung dose for female rats may help explain the flat neoplasm response in male rats. This does not explain the differences in neoplasm responses in rats compared to mice. However, when the total dose is corrected for body weight, mice received a three- to fivefold higher dose of vanadium than rats at comparable exposure concentrations of 1 and 2 mg/m³. Therefore, on a body weight basis, mice received considerably more vanadium than rats, and this may help explain the differences in neoplasm responses between the species.

To establish if the lung neoplasms induced in mice were unique to vanadium pentoxide, genetic alterations in the *K-ras* oncogene and the *p53* tumor suppressor gene were investigated. There was no evidence for a role of *p53* loss in alveolar/bronchiolar carcinoma in B6C3F₁ mice exposed to vanadium pentoxide. However, genetic alterations in the *K-ras* oncogene indicated that a high frequency (73%) of *K-ras* mutations were identified in vanadium pentoxide-induced alveolar/bronchiolar carcinomas compared to those of untreated B6C3F₁ mice (30%) (Appendix O). Additional evidence indicated that a loss of heterozygosity on chromosome 6 (in the region of the *K-ras* gene) was detected in 17 of 19 samples with *K-ras* mutations. These findings suggest that the mechanism of lung carcinogenesis following vanadium pentoxide exposure was different than that of spontaneously induced lung neoplasms. However, there was not a clear exposure concentration-related response in *K-ras* mutations or in loss of heterozygosity, which may be explained by lung burden analysis.

Vanadium pentoxide appears to be slightly soluble in the lung, and as such, may be cytotoxic. The biological mechanism and the initiation and promotion of pulmonary disease and lung cancer induced by vanadium pentoxide is not understood. However, it is apparent that TNF- α , IL-6, IL-8, and macrophage inflammatory

proteins, mediators of pulmonary fibrogenesis and other proliferative and inflammatory responses in the lung, are induced by vanadium pentoxide and ROFA (Pierce *et al.*, 1996; Bonner *et al.*, 1998; Silbajoris *et al.*, 2000). The intracellular signaling mechanism by which vanadium pentoxide and ROFA induce inflammatory mediators is not entirely known. However, it is thought to occur through a cascade of events initiated by accumulation of protein tyrosines that activate mitogen-activated protein kinase and, in turn, initiate transcription of NF- κ B, which is required for induction of TNF- α and other cytokines and chemokines (Chen *et al.*, 1999; Ye *et al.*, 1999).

A wide range of proliferative lesions in the lungs were observed in rats and mice exposed to vanadium pentoxide for 2 years. The incidences of hyperplasia of the alveolar and bronchiolar epithelium were increased in exposed rats and mice and, although given two separate diagnoses, were considered to be one pathogenic process. This change was striking and appeared more prominent than has been observed in other NTP inhalation studies. Although the exact pathogenesis was not determined in the present study, morphologically, the hyperplasia of the alveolar and bronchiolar epithelium was consistent with bronchiolization, a process where bronchiolar epithelium proliferates and migrates down into alveolar ducts and adjacent alveoli. While there was clearly proliferation, it was thought primarily to represent a metaplastic change. Whether this represented a precursor lesion for development of pulmonary neoplasms is not known. However, one might assume an association in the mice because the incidences of both hyperplasia and neoplasia were very high. In contrast, the hyperplasia in rats, although qualitatively similar to that observed in mice, was somewhat more severe, but fewer neoplasms occurred in the rats. Also, the incidences of pulmonary neoplasms were the same in rats exposed to 0.5 or 2 mg/m³, but bronchiolization was much greater in incidence and severity in the 2 mg/m³ group. In another NTP study, high incidences of bronchiolization were observed in male and female mice exposed to *p*-nitrotoluene in dosed feed (NTP, 2002) with only slight increases in the incidences of lung neoplasms in male mice. Admittedly, there could be subtle morphological differences between rats and mice in the hyperplastic lesions that were not identified by light microscopy.

Squamous metaplasia of the alveolar epithelium occurred in 21 of 50 male and 6 of 50 female rats exposed to 2.0 mg/m³ vanadium pentoxide in the 2-year study. Squamous epithelium is not a normal component of the lung parenchyma. It is a more resilient epithelium and its occurrence in the lung generally represents a response to injury. Some degree of squamous metaplasia is common in animals exposed to inhaled particulates, and this lesion has been observed in various NTP inhalation studies including indium phosphide and cobalt sulfate heptahydrate (NTP, 1998, 2001). Though generally consistent with the range of squamous metaplasia seen in other studies, there appears to be a greater degree of keratinization of the lesions in the study of vanadium pentoxide. In the squamous epithelium of the skin, there is proliferation of the basal layer with gradual keratinization and sloughing of the superficial layers. With squamous metaplasia of the alveoli, similar proliferation occurs, and the keratinized material often collects, and in some cases, forms cysts, as occurred in this study.

In other studies, squamous metaplasia generally occurred within areas of moderate to severe chronic inflammation, but this association was not as strong in rats exposed to vanadium. The squamous metaplasia appeared to have more layers, more keratin production, and the lesions were often focally extensive and more proliferative than one might expect with simple squamous metaplasia. Therefore, squamous cell carcinoma was considered to be a differential diagnosis in some instances. Although these lesions were quite florid, there were several features that suggested they were not squamous cell carcinoma. The most definitive evidence of malignant neoplasia is distant metastasis, which was not seen in any animals. Local invasion is another trait of malignant neoplasia that was not an obvious component in the squamous lesions. Additionally, areas of respiratory metaplasia were often admixed with the squamous metaplasia. This would not be expected with neoplasia, particularly squamous cell carcinoma. However, the pathogenesis or biological behavior of these lesions was not determined.

Characterization of squamous lesions of the lung is problematic, partly because these lesions occur infrequently and little is known about their biological behavior. An international workshop of toxicologic pathologists with

expertise in pulmonary pathology reviewed squamous lesions of rat lungs to provide morphologic characterization of cystic keratinizing squamous lesions and discussed all other squamous lesions of the lung (Boorman *et al.*, 1996). Some members of this workshop also participated in the Pathology Working Group review of lesions that occurred in the present study in which they agreed that these lesions did not readily fit into any of the categories used in the workshop. The Pathology Working Group also agreed that the term squamous metaplasia, though imperfect, best described the observed change. Although little is known about the specific squamous lesions observed in this study, in rare instances in NTP studies, squamous cell carcinoma appears to arise from the wall of squamous cysts. There is also evidence of squamous cell carcinoma arising from congenital cysts in humans (Usui *et al.*, 1991). The spectrum of squamous lesions appears for the most part to be peculiar to the rat, so there is no opportunity for comparative human pathology studies.

CONCLUSIONS

Under the conditions of this 2-year inhalation study, there was *some evidence of carcinogenic activity** of vanadium pentoxide in male F344/N rats and *equivocal evidence of carcinogenic activity* of vanadium pentoxide in female F344/N rats based on the occurrence of alveolar/bronchiolar neoplasms. There was *clear evidence of carcinogenic activity* of vanadium pentoxide in male and female B6C3F₁ mice based on increased incidences of alveolar/bronchiolar neoplasms.

Exposure to vanadium pentoxide caused a spectrum of nonneoplastic lesions in the respiratory tract (nose, larynx, and lung) including alveolar and bronchiolar epithelium hyperplasia, inflammation, fibrosis, and alveolar histiocytosis of the lung in male and female rats and mice and an unusual squamous metaplasia of the lung in male and female rats. Hyperplasia of the bronchial lymph node occurred in female mice.

* Explanation of Levels of Evidence of Carcinogenic Activity is on page 12. A Summary of the Technical Reports Review Subcommittee comments and the public discussion on the Technical Report appears on page 14.

REFERENCES

- Altamirano, M., Ayala, M.E., Flores, A., Morales, L., and Dominguez, R. (1991). Sex differences in the effects of vanadium pentoxide administration to prepubertal rats. *Med. Sci. Res.* **19**, 825-826.
- Altamirano-Lozano, M., Alvarez-Barrera, L., and Roldán-Reyes, E. (1993). Cytogenic and teratogenic effects of vanadium pentoxide on mice. *Med. Sci. Res.* **21**, 711-713.
- Altamirano-Lozano, M., Alvarez-Barrera, L., Basurto-Alcántara, F., Valverde, M., and Rojas, E. (1996). Reprotoxic and genotoxic studies of vanadium pentoxide in male mice. *Teratog. Carcinog. Mutagen.* **16**, 7-17.
- Altamirano-Lozano, M., Valverde, M., Alvarez-Barrera, L., Molina, B., and Rojas, E. (1999). Genotoxic studies of vanadium pentoxide (V₂O₅) in male mice. II. Effects in several mouse tissues. *Teratog. Carcinog. Mutagen.* **19**, 243-255.
- American Conference of Governmental Industrial Hygienists (ACGIH) (2001). *2001 TLVs[®] and BEIs[®]. Threshold Limit Values for Chemical Substances and Physical Agents & Biological Exposure Indices*, pp. 59 and 92. Cincinnati, OH.
- Ashby, J., and Tennant, R.W. (1991). Definitive relationships among chemical structure, carcinogenicity and mutagenicity for 301 chemicals tested by the U.S. NTP. *Mutat. Res.* **257**, 229-306.
- Bailer, A.J., and Portier, C.J. (1988). Effects of treatment-induced mortality and tumor-induced mortality on tests for carcinogenicity in small samples. *Biometrics* **44**, 417-431.
- Barbier, F., and Teulon, F. (1989). Two case studies of toxicological monitoring after exposure to thallium sulfate and vanadium pentoxide [in French, English summary]. *Arch. Mal. Prof.* **50**, 447-451.
- Bieler, G.S., and Williams, R.L. (1993). Ratio estimates, the delta method, and quantal response tests for increased carcinogenicity. *Biometrics* **49**, 793-801.
- Bonner, J.C., Lindroos, P.M., Rice, A.B., Moomaw, C.R., and Morgan, D.L. (1998). Induction of PDGF receptor- α in rat myofibroblasts during pulmonary fibrogenesis in vivo. *Am. J. Physiol. Lung Cell Mol. Physiol.* **274**, L72-L80.
- Bonner, J.C., Rice, A.B., Moomaw, C.R., and Morgan, D.L. (2000). Airway fibrosis in rats induced by vanadium pentoxide. *Am. J. Physiol. Lung Cell Mol. Physiol.* **278**, L209-L216.
- Boorman, G.A., Montgomery, C.A., Jr., Eustis, S.L., Wolfe, M.J., McConnell, E.E., and Hardisty, J.F. (1985). Quality assurance in pathology for rodent carcinogenicity studies. In *Handbook of Carcinogen Testing* (H.A. Milman and E.K. Weisburger, Eds.), pp. 345-357. Noyes Publications, Park Ridge, NJ.
- Boorman, G.A., Brockmann, M., Carlton, W.W., Davis, J.M.G., Dungworth, D.L., Hahn, F.F., Mohr, U., Reichhelm, H.-B.R., Turusov, V.S., and Wagner, B.M. (1996). Classification of cystic keratinizing squamous lesions of the rat lung: Report of a workshop. *Toxicol. Pathol.* **24**, 564-572.
- Bosque, M.A., Domingo, J.L., Llobet, J.M., and Corbella, J. (1993). Variability in the embryotoxicity and fetotoxicity of vanadate with the day of exposure. *Vet. Hum. Toxicol.* **35**, 1-3.
- Cam, M.C., Brownsey, R.W., and McNeill, J.H. (2000). Mechanisms of vanadium action: Insulin-mimetic or insulin-enhancing agent? *Can. J. Physiol. Pharmacol.* **78**, 829-847.
- Chen, F., Demers, L.M., Vallyathan, V., Ding, M., Lu, Y., Castranova, V., and Shi, X. (1999). Vanadate induction of NF- κ B involves I κ B kinase β and SAPK/ERK kinase 1 in macrophages. *J. Biol. Chem.* **274**, 20,307-20,312.

- Code of Federal Regulations (CFR) **21**, Part 58.
- Cohen, M.D., Wei, C.I., Tan, H., and Kao, K.J. (1986). Effect of ammonium metavanadate on the murine immune response. *J. Toxicol. Environ. Health* **19**, 279-298.
- Cohen, M.D., Yang, Z., Zelikoff, J.T., and Schlesinger, R.B. (1996). Pulmonary immunotoxicity of inhaled ammonium metavanadate in Fisher 344 rats. *Fundam. Appl. Toxicol.* **33**, 254-263.
- Conklin, A.W., Skinner, C.S., Felten, T.L., and Sanders, C.L. (1982). Clearance and distribution of intratracheally instilled ⁴⁸vanadium compounds in the rat. *Toxicol. Lett.* **11**, 199-203.
- Cox, D.R. (1972). Regression models and life-tables. *J. R. Stat. Soc.* **B34**, 187-220.
- Crans, D.C. (2000). Chemistry and insulin-like properties of vanadium(IV) and vanadium(V) compounds. *J. Inorg. Biochem.* **80**, 123-131.
- Crans, D.C., Amin, S.S., and Keramidias, A.D. (1998). Chemistry of relevance to vanadium in the environment. In *Vanadium in the Environment. Part One: Chemistry and Biochemistry* (J.O. Nriagu, Ed.), pp. 73-96. John Wiley and Sons, New York.
- Crawford, B.D. (1985). Perspectives on the somatic mutation model of carcinogenesis. In *Advances in Modern Environmental Toxicology. Mechanisms and Toxicity of Chemical Carcinogens and Mutagens* (M.A. Mehlman, W.G. Flamm, and R.J. Lorentzen, Eds.), pp. 13-59. Princeton Scientific Publishing Co., Inc., Princeton, NJ.
- Dimond, E.G., Caravaca, J., and Benchimol, A. (1963). Vanadium. Excretion, toxicity, lipid effect in man. *Am. J. Clin. Nutr.* **12**, 49-53.
- Dixon, W.J., and Massey, F.J., Jr. (1951). *Introduction to Statistical Analysis*, 1st ed., pp. 145-147. McGraw-Hill Book Company, Inc., New York.
- Dreher, K.L., Jaskot, R.H., Lehmann, J.R., Richards, J.H., McGee, J.K., Ghio, A.J., and Costa, D.L. (1997). Soluble transition metals mediate residual oil fly ash induced acute lung injury. *J. Toxicol. Environ. Health* **50**, 285-305.
- Dunn, O.J. (1964). Multiple comparisons using rank sums. *Technometrics* **6**, 241-252.
- Dunnett, C.W. (1955). A multiple comparison procedure for comparing several treatments with a control. *J. Am. Stat. Assoc.* **50**, 1096-1121.
- Faulkner Hudson, T.G. (1964). Vanadium. Toxicology and biological significance. In *Elsevier Monographs on Toxic Agents* (E. Browning, Ed.). Elsevier Publishing Company, Amsterdam.
- Fisher, G.L., McNeill, K.L., and Democko, C.J. (1986). Trace element interactions affecting pulmonary macrophage cytotoxicity. *Environ. Res.* **39**, 164-171.
- French, R.J., and Jones, P.J.H. (1993). Role of vanadium in nutrition: Metabolism, essentiality and dietary considerations. *Life Sci.* **52**, 339-346.
- Gavett, S.H., Madison, S.L., Dreher, K.L., Winsett, D.W., McGee, J.K., and Costa, D.L. (1997). Metal and sulfate composition of residual oil fly ash determines airway hyperreactivity and lung injury in rats. *Environ. Res.* **72**, 162-172.
- Gibson, D.P., Brauninger, R., Shaffi, H.S., Kerckaert, G.A., LeBoeuf, R.A., Isfort, R.J., and Aardema, M.J. (1997). Induction of micronuclei in Syrian hamster embryo cells: Comparison to results in the SHE cell transformation assay for National Toxicology Program test chemicals. *Mutat. Res.* **392**, 61-70.
- Goldfine, A.B., Patti, M.-E., Zuberi, L., Goldstein, B.J., LeBlanc, R., Landaker, E.J., Jiang, Z.Y., Willsky, G.R., and Kahn, C.R. (2000). Metabolic effects of vanadyl sulfate in humans with non-insulin-dependent diabetes mellitus: In vivo and in vitro studies. *Metabolism* **49**, 400-410.
- Hahn, F.F. (1993). Chronic inhalation bioassays for respiratory tract carcinogenesis. In *Target Organ Toxicology Series: Toxicology of the Lung* (D.E. Gardner, J.D. Crapo, and R.O. McClellan, Eds.), 2nd ed., p. 435. Raven Press, New York.
- Hamel, F.G. (1998). Endocrine control of vanadium accumulation. In *Vanadium in the Environment. Part Two: Health Effects* (J.O. Nriagu, Ed.), pp. 265-276. John Wiley and Sons, New York.

- Haseman, J.K., Young, E., Eustis, S.L., and Hailey, J.R. (1997). Body weight-tumor incidence correlations in long-term rodent carcinogenicity studies. *Toxicol. Pathol.* **25**, 256-263.
- Hauser, R., Elreedy, S., Hoppin, J.A., and Christiani, D.C. (1995a). Upper airway response in workers exposed to fuel oil ash: nasal lavage analysis. *Occup. Environ. Med.* **52**, 353-358.
- Hauser, R., Elreedy, S., Hoppin, J.A., and Christiani, D.C. (1995b). Airway obstruction in boiler-makers exposed to fuel oil ash. *Am. J. Respir. Crit. Care Med.* **152**, 1478-1484.
- Hazardous Substances Data Bank (HSDB) (2001). Ammonium Metavanadate (updated 29 September 2000). Maintained by the National Library of Medicine. Retrieved 29 June 2001 from the World Wide Web: <<http://www.toxnet.nlm.nih.gov/cgi-bin/sis/htmlgen?HSDB>>.
- Hollander, M., and Wolfe, D.A. (1973). *Nonparametric Statistical Methods*, pp. 120-123. John Wiley and Sons, New York.
- Integrated Laboratory Systems (ILS) (1990). Micronucleus Data Management and Statistical Analysis Software, Version 1.4. ILS, P.O. Box 13501, Research Triangle Park, NC 27707.
- Jain, N.C. (1986). *Schalm's Veterinary Hematology*, 4th ed., pp. 563-576 and 790-820. Lea and Febiger, Philadelphia.
- Jonckheere, A.R. (1954). A distribution-free k -sample test against ordered alternatives. *Biometrika* **41**, 133-145.
- Kanematsu, N., Hara, M., and Kada, T. (1980). Rec assay and mutagenicity studies on metal compounds. *Mutat. Res.* **77**, 109-116.
- Kaplan, E.L., and Meier, P. (1958). Nonparametric estimation from incomplete observations. *J. Am. Stat. Assoc.* **53**, 457-481.
- Kawai, T., Seiji, K., Watanabe, T., Nakatsuka, H., and Ikeda, M. (1989). Urinary vanadium as a biological indicator of exposure to vanadium. *Int. Arch. Occup. Environ. Health* **61**, 283-287.
- Kirk-Othmer Encyclopedia of Chemical Technology* (1983). 3rd ed. (M. Grayson and D. Eckroth, Eds.), Vol. 23, pp. 673-687. John Wiley and Sons, New York.
- Kiviluoto, M., Pyy, L., and Pakarinen, A. (1981). Serum and urinary vanadium of workers processing vanadium pentoxide. *Int. Arch. Occup. Environ. Health* **48**, 251-256.
- Knecht, E.A., Moorman, W.J., Clark, J.C., Lynch, D.W., and Lewis, T.R. (1985). Pulmonary effects of acute vanadium pentoxide inhalation in monkeys. *Am. Rev. Respir. Dis.* **132**, 1181-1185.
- Knecht, E.A., Moorman, W.J., Clark, J.C., Hull, R.D., Biagini, R.E., Lynch, D.W., Boyle, T.J., and Simon, S.D. (1992). Pulmonary reactivity to vanadium pentoxide following subchronic inhalation exposure in a non-human primate animal model. *J. Appl. Toxicol.* **12**, 427-434.
- Kodavanti, U.P., Hauser, R., Christiani, D.C., Meng, Z.H., McGee, J., Ledbetter, A., Richards, J., and Costa, D.L. (1998). Pulmonary responses to oil fly ash particles in the rat differ by virtue of their specific soluble metals. *Toxicol. Sci.* **43**, 204-212.
- Kučera, J., Byrne, A.R., Mravcová, A., and Lener, J. (1992). Vanadium levels in hair and blood of normal and exposed persons. *Sci. Total Environ.* **15**, 191-205.
- Kyono, H., Serita, F., Toya, T., Kubota, H., Arito, H., Takahashi, M., Maruyama, R., Homma, K., Ohta, H., Yamauchi, Y., Nakakita, M., Seki, Y., Ishihara, Y., and Kagawa, J. (1999). A new model rat with acute bronchiolitis and its application to research on the toxicology of inhaled particulate matter. *Ind. Health* **37**, 47-54.
- Lagerkvist, B., Nordberg, G.F., and Vouk, V. (1986). Vanadium. In *Handbook on the Toxicology of Metals. Vol. II. Specific Metals*, 2nd ed. (L. Friberg, G.F. Nordberg, and V.B. Vouk, Eds.), pp. 638-663. Elsevier, Amsterdam.
- Lener, J., Kučera, J., Kodl, M., and Skokanová, V. (1998). Health effects of environmental exposure to vanadium. In *Vanadium in the Environment. Part Two: Health Effects* (J.O. Nriagu, Ed.), pp. 1-20. John Wiley and Sons, New York.

- Léonard, A., and Gerber, G.B. (1994). Mutagenicity, carcinogenicity and teratogenicity of vanadium compounds. *Mutat. Res.* **317**, 81-88.
- Levy, B.S., Hoffman, L., and Gottsegen, S. (1984). Boilermakers' bronchitis. *J. Occup. Med.* **26**, 567-570.
- Lewis, R.J., Sr., Ed. (1997). *Hawley's Condensed Chemical Dictionary*, 13th ed., pp. 1163-1164. Van Nostrand Reinhold, New York.
- Lewis, R.J., Sr. (2000). *Sax's Dangerous Properties of Industrial Materials*, 10th ed., pp. 3657-3660. John Wiley and Sons, Inc., New York.
- Li, S., Zhang, T., Yang, Z., and Gou, X. (1991). Distribution of vanadium in tissues of nonpregnant and pregnant Wistar rats [in Chinese, English abstract]. *J. West China Univ. Med. Sci.* **22**, 196-200.
- McConnell, E.E., Solleveld, H.A., Swenberg, J.A., and Boorman, G.A. (1986). Guidelines for combining neoplasms for evaluation of rodent carcinogenesis studies. *JNCI* **76**, 283-289.
- MacGregor, J.T., Wehr, C.M., Henika, P.R., and Shelby, M.D. (1990). The *in vivo* erythrocyte micronucleus test: Measurement at steady state increases assay efficiency and permits integration with toxicity studies. *Fundam. Appl. Toxicol.* **14**, 513-522.
- Madsen, K.L., Porter, V.M., and Fedorak, R.N. (1993). Oral vanadate reduces Na⁺-dependent glucose transport in rat small intestine. *Diabetes* **42**, 1126-1132.
- Mamane, Y., and Pirrone, N. (1998). Vanadium in the atmosphere. In *Vanadium in the Environment. Part One: Chemistry and Biochemistry* (J.O. Nriagu, Ed.), pp. 37-72. John Wiley and Sons, New York.
- Maronpot, R.R., and Boorman, G.A. (1982). Interpretation of rodent hepatocellular proliferative alterations and hepatocellular tumors in chemical safety assessment. *Toxicol. Pathol.* **10**, 71-80.
- The Merck Index* (1996). 12th ed. (S. Budavari, Ed.), p. 1692. Merck and Company, Rahway, NJ.
- Migliore, L., Bocciardi, R., Macri, C., and Lo Jacono, F. (1993). Cytogenetic damage induced in human lymphocytes by four vanadium compounds and micronucleus analysis by fluorescence in situ hybridization with a centromeric probe. *Mutat. Res.* **319**, 205-213.
- Miller, J.A., and Miller, E.C. (1977). Ultimate chemical carcinogens as reactive mutagenic electrophiles. In *Origins of Human Cancer* (H.H. Hiatt, J.D. Watson, and J.A. Winsten, Eds.), pp. 605-627. Cold Spring Harbor Laboratory, Cold Spring Harbor, NY.
- Morrison, D.F. (1976). *Multivariate Statistical Methods*, 2nd ed., pp. 170-179. McGraw-Hill Book Company, New York.
- Motolese, A., Truzzi, M., Giannini, A., and Seidenari, S. (1993). Contact dermatitis and contact sensitization among enamellers and decorators in the ceramics industry. *Contact Dermatitis* **28**, 59-62.
- Mravcová, A., Jírová, D., Jancí, H., and Lener, J. (1993). Effects of orally administered vanadium on the immune system and bone metabolism in experimental animals. *Sci. Total Environ. Supplement*, 663-669.
- Musk, A.W., and Tees, J.G. (1982). Asthma caused by occupational exposure to vanadium compounds. *Med. J. Aust.* **1**, 183-184.
- National Cancer Institute (NCI) (1978). Bioassay of 1,5-Naphthalenediamine for Possible Carcinogenicity (CAS No. 2243-62-1). Technical Report Series No. 143. NIH Publication No. 78-1398. U.S. Department of Health, Education, and Welfare, Public Health Service, National Institutes of Health, Bethesda, MD.
- National Cancer Institute (NCI) (1979). Bioassay of 3,3'-Dimethoxybenzidine-4,4'-diisocyanate for Possible Carcinogenicity (CAS No. 91-93-0). Technical Report Series No. 128. NIH Publication No. 79-1383. U.S. Department of Health, Education, and Welfare, Public Health Service, National Institutes of Health, Bethesda, MD.
- National Institute for Occupational Safety and Health (NIOSH) (1990). National Occupational Exposure Survey (1981-1983), unpublished provisional data as of July 1, 1990. NIOSH, Cincinnati, OH.

National Institute for Occupational Safety and Health (NIOSH) (1997). NIOSH Pocket Guide To Chemical Hazards, p. 328. U.S. Department of Health and Human Services, Public Health Service, Centers for Disease Control and Prevention, Washington, D.C.

National Toxicology Program (NTP) (1987). Technical Protocol for Sperm Morphology and Vaginal Cytology Evaluations in Toxicity Testing for Rats and Mice, 10/31/82 version (updated April 1987). Research Triangle Park, NC.

National Toxicology Program (NTP) (1993a). Toxicity Studies of Cupric Sulfate (CAS No. 7758-99-8) in F344/N Rats and B6C3F₁ Mice (Drinking Water and Feed Studies). Toxicity Report Series No. 29. NIH Publication No. 93-3352. U.S. Department of Health and Human Services, Public Health Service, National Institutes of Health, Research Triangle Park, NC.

National Toxicology Program (NTP) (1993b). Toxicology and Carcinogenesis Studies of Talc (CAS No. 14807-96-6) in F344/N Rats and B6C3F₁ Mice (Inhalation Studies). Technical Report Series No. 421. NIH Publication No. 93-3152. U.S. Department of Health and Human Services, Public Health Service, National Institutes of Health, Research Triangle Park, NC.

National Toxicology Program (NTP) (1994). Toxicity Studies of Sodium Selenate and Sodium Selenite (CAS Nos. 13410-10-0 and 10102-18-8) in F344/N Rats and B6C3F₁ Mice (Drinking Water Studies). Toxicity Report Series No. 38. NIH Publication No. 94-3387. U.S. Department of Health and Human Services, Public Health Service, National Institutes of Health, Research Triangle Park, NC.

National Toxicology Program (NTP) (1996a). Toxicology and Carcinogenesis Studies of Nickel Subsulfide (CAS No. 12035-72-2) in F344/N Rats and B6C3F₁ Mice (Inhalation Studies). Technical Report Series No. 453. NIH Publication No. 96-3369. U.S. Department of Health and Human Services, Public Health Service, National Institutes of Health, Research Triangle Park, NC.

National Toxicology Program (NTP) (1996b). Toxicology and Carcinogenesis Studies of Nickel Oxide (CAS No. 1313-99-1) in F344/N Rats and B6C3F₁ Mice (Inhalation Studies). Technical Report Series No. 451. NIH Publication No. 96-3367. U.S. Department of Health and Human Services, Public Health Service, National Institutes of Health, Research Triangle Park, NC.

National Toxicology Program (NTP) (1997). Toxicology and Carcinogenesis Studies of Molybdenum Trioxide (CAS No. 1313-27-5) in F344/N Rats and B6C3F₁ Mice (Inhalation Studies). Technical Report Series No. 462. NIH Publication No. 97-3378. U.S. Department of Health and Human Services, Public Health Service, National Institutes of Health, Research Triangle Park, NC.

National Toxicology Program (NTP) (1998). Toxicology and Carcinogenesis Studies of Cobalt Sulfate Heptahydrate (CAS No. 10026-24-1) in F344/N Rats and B6C3F₁ Mice (Inhalation Studies). Technical Report Series No. 471. NIH Publication No. 98-3961. U.S. Department of Health and Human Services, Public Health Service, National Institutes of Health, Research Triangle Park, NC.

National Toxicology Program (NTP) (2000). Toxicology and Carcinogenesis Studies of Gallium Arsenide (CAS No. 1303-00-0) in F344/N Rats and B6C3F₁ Mice (Inhalation Studies). Technical Report Series No. 492. NIH Publication No. 00-3951. U.S. Department of Health and Human Services, Public Health Service, National Institutes of Health, Research Triangle Park, NC.

National Toxicology Program (NTP) (2001). Toxicology and Carcinogenesis Studies of Indium Phosphide (CAS No. 22398-80-7) in F344/N Rats and B6C3F₁ Mice (Inhalation Studies). Technical Report Series No. 499. NIH Publication No. 01-4433. U.S. Department of Health and Human Services, Public Health Service, National Institutes of Health, Research Triangle Park, NC.

- National Toxicology Program (NTP) (2002). Toxicology and Carcinogenesis Studies of *p*-Nitrotoluene (CAS No. 99-99-0) in F344/N Rats and B6C3F₁ Mice (Feed Studies). Technical Report Series No. 498. NIH Publication No. 02-4432. U.S. Department of Health and Human Services, Public Health Service, National Institutes of Health, Research Triangle Park, NC.
- Nechay, B.R., Nanninga, L.B., and Nechay, P.S.E. (1986). Vanadyl (IV) and vanadate (V) binding to selected endogenous phosphate, carboxyl, and amino ligands; calculations of cellular vanadium species distribution. *Arch. Biochem. Biophys.* **251**, 128-138.
- Nriagu, J.O. (1998). History, occurrence, and uses of vanadium. In *Vanadium in the Environment. Part One: Chemistry and Biochemistry* (J.O. Nriagu, Ed.), pp. 1-24. John Wiley and Sons, New York.
- Nyquist, R.A., and Kagel, R.O. (1971). *Infrared Spectra of Inorganic Compounds*, Spectrum No. 335, pp. 216-217. Academic Press, Inc., Orlando, FL.
- Oberg, S.G., Parker, R.D.R., and Sharma, R.P. (1978). Distribution and elimination of an intratracheally administered vanadium compound in the rat. *Toxicology* **11**, 315-323.
- Paternain, J.L., Domingo, J.L., Gómez, M., Ortega, A., and Corbella, J. (1990). Developmental toxicity of vanadium in mice after oral administration. *J. Appl. Toxicol.* **10**, 181-186.
- Patty's Industrial Hygiene and Toxicology* (1981). Vanadium. 3rd ed. (G.D. Clayton and F.E. Clayton, Eds.), pp. 2013-2031. John Wiley and Sons, New York.
- Piegorsch, W.W., and Bailer, A.J. (1997). *Statistics for Environmental Biology and Toxicology*, Section 6.3.2. Chapman and Hall, London.
- Pierce, L.M., Alessandrini, F., Godleski, J.J., and Paulauskis, J.D. (1996). Vanadium-induced chemokine mRNA expression and pulmonary inflammation. *Toxicol. Appl. Pharmacol.* **138**, 1-11.
- Plunkett, E.R. (1987). *Handbook of Industrial Toxicology*, 3rd. ed., pp. 563-564. Chemical Publishing Co., Inc., New York.
- Portier, C.J., and Bailer, A.J. (1989). Testing for increased carcinogenicity using a survival-adjusted quantal response test. *Fundam. Appl. Toxicol.* **12**, 731-737.
- Portier, C.J., Hedges, J.C., and Hoel, D.G. (1986). Age-specific models of mortality and tumor onset for historical control animals in the National Toxicology Program's carcinogenicity experiments. *Cancer Res.* **46**, 4372-4378.
- Poucheret, P., Verma, S., Grynepas, M.D., and McNeill, J.H. (1998). Vanadium and diabetes. *Mol. Cell. Biochem.* **188**, 73-80.
- Ramanadham, S., Heyliger, C., Gresser, M.J., Tracey, A.S., and McNeill, J.H. (1991). The distribution and half-life for retention of vanadium in the organs of normal and diabetic rats orally fed vanadium (IV) and vanadium (V). *Biol. Trace Elem. Res.* **30**, 119-124.
- Ramírez, P., Eastmond, D.A., Laclette, J.P., and Ostrosky-Wegman, P. (1997). Disruption of microtubule assembly and spindle formation as a mechanism for the induction of aneuploid cells by sodium arsenite and vanadium pentoxide. *Mutat. Res.* **386**, 291-298.
- Rao, G.N. (1996). New diet (NTP-2000) for rats in the National Toxicology Program toxicity and carcinogenicity studies. *Fundam. Appl. Toxicol.* **32**, 102-108.
- Rao, G.N. (1997). New nonpurified diet (NTP-2000) for rodents in the National Toxicology Program's toxicology and carcinogenesis studies. *J. Nutr.* **127**, 842s-846s.
- Registry of Toxic Effects of Chemical Substances (RTECS) (2001). Vanadic (II) Acid, Trisodium Salt. Maintained by the National Library of Medicine. Retrieved 29 June 2001 from the World Wide Web: <<http://www.tomescps.com/assm.asp?RTYW1120000>>.
- Rhoads, K., and Sanders, C.L. (1985). Lung clearance, translocation, and acute toxicity of arsenic, beryllium, cadmium, cobalt, lead, selenium, vanadium, and ytterbium oxides following deposition in rat lung. *Environ. Res.* **36**, 359-378.
- Rice, A.B., Moomaw, C.R., Morgan, D.L., and Bonner, J.C. (1999). Specific inhibitors of platelet-derived growth factor or epidermal growth factor receptor tyrosine kinase reduce pulmonary fibrosis in rats. *Am. J. Pathol.* **155**, 213-221.

- Rojas, E., Valverde, M., Herrera, L.A., Altamirano-Lozano, M., and Ostrosky-Wegman, P. (1996). Genotoxicity of vanadium pentoxide evaluate by the single cell gel electrophoresis assay in human lymphocytes. *Mutat. Res.* **359**, 77-84.
- Roldán, R.E., and Altamirano, L.M.A. (1990). Chromosomal aberrations, sister-chromatid exchanges, cell-cycle kinetics and satellite associations in human lymphocyte cultures exposed to vanadium pentoxide. *Mutat. Res.* **245**, 61-65.
- Rosen, F. (1959). The specificity of the glutamic pyruvic transaminase response. *Endocrinology* **65**, 256-264.
- Rosen, F., Roberts, N.R., and Nichol, C.A. (1959). Glucocorticosteroids and transaminase activity. I. Increased activity of glutamic-pyruvic transaminase in four conditions associated with gluconeogenesis. *J. Biol. Chem.* **234**, 476-480.
- Ross, D.S. (1983). Case study: Exposure to vanadium pentoxide. *Occup. Health (Lond.)* **35**, 67-71.
- Ryan, R.P., Terry, C.E., and Leffingwell, S.S., Eds. (1999). *Toxicology Desk Reference: The Toxic Exposure and Medical Monitoring Index*, 5th ed., Vol. 2, 1211-1217. Taylor and Francis, Philadelphia, PA.
- Sakurai, H. (1994). Vanadium distribution in rats and DNA cleavage by vanadyl complex: Implication for vanadium toxicity and biological effects. *Environ. Health Perspect.* **102**, 35-36.
- Schiff, L.J., and Graham, J.A. (1984). Cytotoxic effect of vanadium and oil-fired fly ash on hamster tracheal epithelium. *Environ. Res.* **34**, 390-402.
- Sharma, R.P., Flora, S.J.S., Drown, D.B., and Oberg, S.G. (1987). Persistence of vanadium compounds in lungs after intratracheal instillation in rats. *Toxicol. Ind. Health* **3**, 321-329.
- Shelby, M.D. (1988). The genetic toxicity of human carcinogens and its implications. *Mutat. Res.* **204**, 3-15.
- Shelby, M.D., and Witt, K.L. (1995). Comparison of results from mouse bone marrow chromosome aberration and micronucleus tests. *Environ. Mol. Mutagen.* **25**, 302-313.
- Shelby, M.D., and Zeiger, E. (1990). Activity of human carcinogens in the Salmonella and rodent bone-marrow cytogenetics tests. *Mutat. Res.* **234**, 257-261.
- Shelby, M.D., Erexson, G.L., Hook, G.J., and Tice, R.R. (1993). Evaluation of a three-exposure mouse bone marrow micronucleus protocol: Results with 49 chemicals. *Environ. Mol. Mutagen.* **21**, 160-179.
- Shi, X., and Dalal, N.S. (1991). Flavoenzymes reduce vanadium (V) and molecular oxygen and generate hydroxyl radical. *Arch. Biochem. Biophys.* **289**, 355-361.
- Shi, X., and Dalal, N.S. (1992). Hydroxyl radical generation in the NADH/microsomal reduction of vanadate. *Free Radic. Res. Commun.* **17**, 369-376.
- Shi, X., and Dalal, N.S. (1993). Vanadate-mediated hydroxyl radical generation from superoxide radical in the presence of NADH: Haber-Weiss vs Fenton mechanism. *Arch. Biochem. Biophys.* **307**, 336-341.
- Shi, X., Jiang, H., Mao, Y., Ye, J., and Saffiotti, U. (1996a). Vanadium (IV)-mediated free radical generation and related 2'-deoxyguanosine hydroxylation and DNA damage. *Toxicology* **106**, 27-38.
- Shi, X., Wang, P., Jiang, H., Mao, Y., Ahmed, N., and Dalal, N. (1996b). Vanadium (IV) causes 2'-deoxyguanosine hydroxylation and deoxyribonucleic acid damage via free radical reactions. *Ann. Clin. Lab. Sci.* **26**, 39-49.
- Shi, X., Flynn, D.C., Liu, K., and Dalal, N. (1997). Vanadium (IV) formation in the reduction of vanadate by glutathione reductase/NADPH and the role of molecular oxygen. *Ann. Clin. Lab. Sci.* **27**, 422-427.
- Shirley, E. (1977). A non-parametric equivalent of Williams' test for contrasting increasing dose levels of a treatment. *Biometrics* **33**, 386-389.
- Silbajoris, R., Ghio, A.J., Samet, J.M., Jaskot, R., Dreher, K.L., and Brighton, L.E. (2000). In vivo and in vitro correlation of pulmonary map kinase activation following metallic exposure. *Inhal. Toxicol.* **12**, 453-468.
- Srivastava, A.K. (2000). Anti-diabetic and toxic effects of vanadium compounds. *Mol. Cell. Biochem.* **206**, 177-182.

- Straus, D.S. (1981). Somatic mutation, cellular differentiation, and cancer causation. *JNCI* **67**, 233-241.
- Sun, Q., Sekar, N., Goldwaser, I., Gershonov, E., Fridkin, M., and Shechter, Y. (2000). Vanadate restores glucose 6-phosphate in diabetic rats: A mechanism to enhance glucose metabolism. *Endocrin. Metab.* **279**, E403-E410.
- Takezawa, J., Miller, F.J., and O'Neil, J.J. (1980). Single-breath diffusing capacity and lung volumes in small laboratory mammals. *J. Appl. Physiol.* **48**, 1052-1059.
- Tarone, R.E. (1975). Tests for trend in life table analysis. *Biometrika* **62**, 679-682.
- Tennant, R.W., Margolin, B.H., Shelby, M.D., Zeiger, E., Haseman, J.K., Spalding, J., Caspary, W., Resnick, M., Stasiewicz, S., Anderson, B., and Minor, R. (1987). Prediction of chemical carcinogenicity in rodents from in vitro genetic toxicity assays. *Science* **236**, 933-941.
- Usui, Y., Takabe, K., Takayama, S., Miura, H., and Kimura, Y. (1991). Minute squamous cell carcinoma arising in the wall of a congenital lung cyst. *Chest* **99**, 235-236.
- Waters, M.D., Gardner, D.E., and Coffin, D.L. (1974). Cytotoxic effects of vanadium on rabbit alveolar macrophages *in vitro*. *Toxicol. Appl. Pharmacol.* **28**, 253-263.
- Wexler, P., Ed. (1998). *Encyclopedia of Toxicology*, Vol. 3, 386-387. Academic Press, San Diego, CA.
- Wide, M. (1984). Effect of short-term exposure to five industrial metals on the embryonic and fetal development of the mouse. *Environ. Res.* **33**, 47-53.
- Williams, D.A. (1971). A test for differences between treatment means when several dose levels are compared with a zero dose control. *Biometrics* **27**, 103-117.
- Williams, D.A. (1972). The comparison of several dose levels with a zero dose control. *Biometrics* **28**, 519-531.
- Witt, K.L., Knapton, A., Wehr, C.M., Hook, G.J., Mirsalis, J., Shelby, M.D., and MacGregor, J.T. (2000). Micronucleated erythrocyte frequency in peripheral blood of B6C3F₁ mice from short-term, prechronic, and chronic studies of the NTP Carcinogenesis Bioassay Program. *Environ. Mol. Mutagen.* **36**, 163-194.
- Woodin, M.A., Hauser, R., Liu, Y., Smith, T.J., Siegel, P.D., Lewis, D.M., Tollerud, D.J., and Christiani, D.C. (1998). Molecular markers of acute upper airway inflammation in workers exposed to fuel-oil ash. *Am. J. Respir. Crit. Care Med.* **158**, 182-187.
- Woodin, M.A., Liu, Y., Neuberg, D., Hauser, R., Smith, T.J., and Christiani, D.C. (2000). Acute respiratory symptoms in workers exposed to vanadium-rich fuel-oil ash. *Am. J. Ind. Med.* **37**, 353-363.
- World Health Organization (WHO) (1988). Vanadium. Environmental Health Criteria 81. WHO, Geneva.
- Ye, J., Ding, M., Zhang, X., Rojanasakul, Y., Nedospasov, S., Vallyathan, V., Castranova, V., and Shi, X. (1999). Induction of TNF α in macrophages by vanadate is dependent on activation of transcription factor NF- κ B and free radical reactions. *Mol. Cell. Biochem.* **198**, 193-200.
- Zaporowska, H., Wasilewski, W., and Słotwińska, M. (1993). Effect of chronic vanadium administration in drinking water to rats. *Biometals* **6**, 3-10.
- Zeiger, E., Haseman, J.K., Shelby, M.D., Margolin, B.H., and Tennant, R.W. (1990). Evaluation of four in vitro genetic toxicity tests for predicting rodent carcinogenicity: Confirmation of earlier results with 41 additional chemicals. *Environ. Mol. Mutagen.* **16** (Suppl. 18), 1-14.

- Zeiger, E., Anderson, B., Haworth, S., Lawlor, T., and Mortelmans, K. (1992). *Salmonella* mutagenicity tests: V. Results from the testing of 311 chemicals. *Environ. Mol. Mutagen.* **19** (Suppl. 21), 2-141.
- Zenz, C., Ed. (1994). *Occupational Medicine*, 3rd ed., pp. 584-594. Mosby, St. Louis, MO.
- Zenz, C., and Berg, B.A. (1967). Human responses to controlled vanadium pentoxide exposure. *Arch. Environ. Health* **14**, 709-712.
- Zhang, T., Yang, Z., Li, S., and Go, X. (1991). Transplacental passage of vanadium after treatment with vanadium pentoxide in Wistar rat [in Chinese, English abstract]. *J. West China Univ. Med. Sci.* **22**, 296-299.
- Zhang, T., Gou, X., and Yang, Z. (1993). Study of teratogenicity and sensitive period of vanadium pentoxide in Wistar rats [in Chinese, English abstract]. *J. West China Univ. Med. Sci.* **24**, 202-205.
- Zhong, B.-Z., Gu, Z.-W., Wallace, W.E., Whong, W.-Z., and Ong, T. (1994). Genotoxicity of vanadium pentoxide in Chinese hamster V79 cells. *Mutat. Res.* **321**, 35-42.
- Zychlinski, L., Byczkowski, J.Z., and Kulkarni, A. (1991). Toxic effects of long-term intratracheal administration of vanadium pentoxide in rats. *Arch. Environ. Contam. Toxicol.* **20**, 295-298.

APPENDIX A
SUMMARY OF LESIONS IN MALE RATS
IN THE 2-YEAR INHALATION STUDY
OF VANADIUM PENTOXIDE

TABLE A1	Summary of the Incidence of Neoplasms in Male Rats in the 2-Year Inhalation Study of Vanadium Pentoxide	110
TABLE A2	Individual Animal Tumor Pathology of Male Rats in the 2-Year Inhalation Study of Vanadium Pentoxide	114
TABLE A3	Statistical Analysis of Primary Neoplasms in Male Rats in the 2-Year Inhalation Study of Vanadium Pentoxide	138
TABLE A4	Historical Incidence of Alveolar/bronchiolar Neoplasms in Control Male F344/N Rats ...	142
TABLE A5	Summary of the Incidence of Nonneoplastic Lesions in Male Rats in the 2-Year Inhalation Study of Vanadium Pentoxide	143

TABLE A1
Summary of the Incidence of Neoplasms in Male Rats in the 2-Year Inhalation Study of Vanadium Pentoxide^a

	Chamber Control	0.5 mg/m ³	1 mg/m ³	2 mg/m ³
Disposition Summary				
Animals initially in study	50	50	50	50
Moribund	25	17	18	13
Natural deaths	5	4	6	10
Survivors				
Terminal sacrifice	20	29	26	27
Animals examined microscopically	50	50	50	50
Alimentary System				
Esophagus	(50)	(50)	(49)	(50)
Intestine large, cecum	(46)	(48)	(45)	(46)
Polyp adenomatous			1 (2%)	
Intestine small, jejunum	(45)	(47)	(45)	(43)
Carcinoma	1 (2%)			
Liver	(50)	(50)	(49)	(50)
Fibrous histiocytoma, metastatic, skin	1 (2%)			
Hepatocellular carcinoma				1 (2%)
Hepatocellular adenoma		1 (2%)		
Sarcoma, metastatic, skin	1 (2%)			
Mesentery	(8)	(18)	(12)	(9)
Fibrous histiocytoma, metastatic, skin	1 (13%)			
Oral mucosa		(3)		(4)
Squamous cell carcinoma				1 (25%)
Squamous cell papilloma		1 (33%)		
Pharyngeal, squamous cell papilloma		1 (33%)		
Pancreas	(50)	(50)	(49)	(50)
Fibrous histiocytoma, metastatic, skin	1 (2%)			
Salivary glands	(49)	(50)	(49)	(50)
Tongue			(1)	(2)
Squamous cell papilloma				1 (50%)
Tooth	(7)	(1)	(2)	(5)
Odontoma				1 (20%)
Cardiovascular System				
Heart	(50)	(50)	(49)	(50)
Carcinoma, metastatic, mammary gland		1 (2%)		
Sarcoma, metastatic, skin	1 (2%)			
Pericardium, alveolar/bronchiolar carcinoma, metastatic, lung			1 (2%)	
Endocrine System				
Adrenal cortex	(50)	(50)	(49)	(50)
Sarcoma, metastatic, skin	1 (2%)			
Adrenal medulla	(50)	(50)	(49)	(50)
Ganglioneuroma				1 (2%)
Pheochromocytoma malignant	1 (2%)	2 (4%)		
Pheochromocytoma complex			2 (4%)	
Pheochromocytoma benign	4 (8%)	10 (20%)	6 (12%)	6 (12%)
Bilateral, pheochromocytoma benign		1 (2%)		

TABLE A1
Summary of the Incidence of Neoplasms in Male Rats in the 2-Year Inhalation Study of Vanadium Pentoxide

	Chamber Control	0.5 mg/m ³	1 mg/m ³	2 mg/m ³
Endocrine System (continued)				
Islets, pancreatic	(50)	(50)	(49)	(50)
Adenoma	1 (2%)	3 (6%)	1 (2%)	2 (4%)
Carcinoma	1 (2%)	4 (8%)	3 (6%)	
Parathyroid gland	(49)	(49)	(48)	(48)
Carcinoma, metastatic, thyroid gland			1 (2%)	
Pituitary gland	(50)	(50)	(50)	(50)
Pars distalis, adenoma	35 (70%)	35 (70%)	39 (78%)	32 (64%)
Pars intermedia, adenoma				1 (2%)
Thyroid gland	(50)	(50)	(49)	(50)
Sarcoma, metastatic, skin		1 (2%)		
C-cell, adenoma	1 (2%)	4 (8%)	4 (8%)	2 (4%)
C-cell, carcinoma			1 (2%)	1 (2%)
Follicular cell, carcinoma			1 (2%)	
General Body System				
Peritoneum			(2)	
Genital System				
Epididymis	(50)	(50)	(49)	(50)
Preputial gland	(50)	(50)	(49)	(50)
Carcinoma		2 (4%)	2 (4%)	2 (4%)
Testes	(50)	(50)	(50)	(50)
Bilateral, interstitial cell, adenoma	21 (42%)	21 (42%)	18 (36%)	23 (46%)
Interstitial cell, adenoma	15 (30%)	11 (22%)	16 (32%)	11 (22%)
Hematopoietic System				
Bone marrow	(50)	(50)	(50)	(50)
Sarcoma, metastatic, skin	1 (2%)			
Lymph node	(2)	(3)	(2)	(5)
Lymph node, bronchial	(39)	(44)	(47)	(44)
Alveolar/bronchiolar carcinoma, metastatic, lung			1 (2%)	
Fibrous histiocytoma, metastatic, skin	1 (3%)			
Sarcoma, metastatic, skin	1 (3%)			
Lymph node, mandibular	(44)	(48)	(46)	(45)
Sarcoma, metastatic, skin	1 (2%)			
Lymph node, mesenteric	(50)	(50)	(49)	(50)
Lymph node, mediastinal	(45)	(47)	(46)	(44)
Alveolar/bronchiolar carcinoma, metastatic, lung			1 (2%)	
Fibrous histiocytoma, metastatic, skin	1 (2%)			
Sarcoma, metastatic, skin	1 (2%)			
Spleen	(50)	(50)	(48)	(50)
Thymus	(49)	(49)	(49)	(50)
Thymoma benign			1 (2%)	
Integumentary System				
Mammary gland	(48)	(50)	(49)	(50)
Carcinoma, multiple		1 (2%)		
Fibroadenoma	2 (4%)	2 (4%)	1 (2%)	

TABLE A1
Summary of the Incidence of Neoplasms in Male Rats in the 2-Year Inhalation Study of Vanadium Pentoxide

	Chamber Control	0.5 mg/m ³	1 mg/m ³	2 mg/m ³
Integumentary System (continued)				
Skin	(50)	(50)	(50)	(50)
Basal cell adenoma		1 (2%)	1 (2%)	
Basal cell adenoma, multiple		1 (2%)		
Basal cell carcinoma			1 (2%)	1 (2%)
Fibrosarcoma	1 (2%)			
Fibrous histiocytoma	1 (2%)			
Keratoacanthoma	3 (6%)	6 (12%)	2 (4%)	2 (4%)
Keratoacanthoma, multiple	1 (2%)			
Neural crest tumor, benign			1 (2%)	
Schwannoma benign			1 (2%)	
Squamous cell papilloma	1 (2%)	1 (2%)		
Trichoepithelioma				1 (2%)
Subcutaneous tissue, fibroma	2 (4%)		4 (8%)	2 (4%)
Subcutaneous tissue, fibrosarcoma			1 (2%)	
Subcutaneous tissue, fibrous histiocytoma	1 (2%)			
Subcutaneous tissue, lipoma	2 (4%)		3 (6%)	1 (2%)
Subcutaneous tissue, sarcoma	1 (2%)	1 (2%)		1 (2%)
Musculoskeletal System				
Bone	(50)	(50)	(50)	(50)
Fibrosarcoma, metastatic, skin	1 (2%)			
Cranium, sarcoma, metastatic, skin	1 (2%)			
Femur, osteosarcoma		1 (2%)		
Mandible, osteosarcoma	1 (2%)			
Skeletal muscle		(2)	(2)	
Alveolar/bronchiolar carcinoma, metastatic, lung			1 (50%)	
Carcinoma, metastatic, mammary gland		1 (50%)		
Nervous System				
Brain	(50)	(50)	(49)	(50)
Glioma malignant		1 (2%)		
Meningioma malignant		1 (2%)		
Respiratory System				
Larynx	(49)	(50)	(50)	(49)
Lung	(50)	(49)	(48)	(50)
Alveolar/bronchiolar adenoma	4 (8%)	6 (12%)	5 (10%)	6 (12%)
Alveolar/bronchiolar adenoma, multiple		2 (4%)		
Alveolar/bronchiolar carcinoma		2 (4%)	1 (2%)	3 (6%)
Alveolar/bronchiolar carcinoma, multiple		1 (2%)		
Alveolar/bronchiolar carcinoma, metastatic, lung			1 (2%)	
Carcinoma, metastatic, mammary gland		1 (2%)		
Fibrous histiocytoma, metastatic, skin	2 (4%)			
Osteosarcoma, metastatic, bone	1 (2%)	1 (2%)		
Pheochromocytoma malignant, metastatic, adrenal medulla		1 (2%)		
Sarcoma, metastatic, skin	1 (2%)			
Squamous cell carcinoma, metastatic, oral mucosa				1 (2%)
Pleura			(2)	(1)
Alveolar/bronchiolar carcinoma, metastatic, lung			1 (50%)	
Trachea	(50)	(50)	(49)	(50)

TABLE A1
Summary of the Incidence of Neoplasms in Male Rats in the 2-Year Inhalation Study of Vanadium Pentoxide

	Chamber Control	0.5 mg/m ³	1 mg/m ³	2 mg/m ³
Special Senses System				
Lacrimal gland	(1)			
Fibrosarcoma, metastatic, skin	1 (100%)			
Urinary System				
Kidney	(50)	(50)	(49)	(50)
Renal tubule, adenoma	1 (2%)			
Renal tubule, carcinoma		1 (2%)		
Urinary bladder	(49)	(50)	(48)	(50)
Papilloma		1 (2%)		1 (2%)
Systemic Lesions				
Multiple organs ^b	(50)	(50)	(50)	(50)
Leukemia mononuclear	22 (44%)	21 (42%)	19 (38%)	17 (34%)
Lymphoma malignant		1 (2%)		
Mesothelioma malignant	1 (2%)		3 (6%)	
Neoplasm Summary				
Total animals with primary neoplasms ^c	50	50	49	49
Total primary neoplasms	124	147	138	120
Total animals with benign neoplasms	48	47	49	46
Total benign neoplasms	93	108	103	93
Total animals with malignant neoplasms	28	31	30	24
Total malignant neoplasms	31	39	35	27
Total animals with metastatic neoplasms	5	4	2	1
Total metastatic neoplasms	19	6	7	1

^a Number of animals examined microscopically at the site and the number of animals with neoplasm

^b Number of animals with any tissue examined microscopically

^c Primary neoplasms: all neoplasms except metastatic neoplasms

TABLE A2
Individual Animal Tumor Pathology of Male Rats in the 2-Year Inhalation Study of Vanadium Pentoxide:
Chamber Control

Number of Days on Study	3	4	5	5	5	5	5	6	6	6	6	6	6	6	6	6	6	6	6	6	6	6	6	6	6	6
	7	7	0	6	8	8	8	1	1	1	1	1	2	2	3	3	5	5	6	6	6	6	6	7	9	9
	3	7	2	1	9	9	9	0	2	7	7	9	4	8	6	8	0	2	6	6	6	6	9	7	4	

Carcass ID Number	0	0	0	0	0	0	0	0	0	0	0	0	0	0	0	0	0	0	0	0	0	0	0	0	0	0
	2	3	3	0	1	1	2	5	0	0	2	4	2	4	3	3	3	1	1	1	2	2	3	0	0	0
	5	6	0	8	5	7	7	0	6	4	3	4	4	9	3	4	1	1	2	4	2	9	7	2	9	9

Alimentary System																												
Esophagus	+	+	+	+	+	+	+	+	+	+	+	+	+	+	+	+	+	+	+	+	+	+	+	+	+	+	+	+
Intestine large, colon	A	+	+	+	A	+	+	+	+	+	+	+	+	+	+	+	A	+	+	+	+	+	A	+	+	+	+	+
Intestine large, rectum	+	+	+	+	A	+	+	+	+	+	+	+	+	+	+	+	A	+	+	+	+	+	A	+	+	+	+	+
Intestine large, cecum	+	+	A	+	A	+	+	+	+	+	+	+	+	+	+	+	A	+	+	+	+	+	A	+	+	+	+	+
Intestine small, duodenum	+	+	+	+	A	+	+	+	+	+	+	+	+	+	+	+	A	+	+	+	+	+	A	+	+	+	+	+
Intestine small, jejunum	A	+	A	+	A	+	+	+	+	+	+	+	+	+	+	+	A	+	+	+	+	+	A	+	+	+	+	+
Carcinoma																												
X																												
Intestine small, ileum	+	+	A	+	A	+	+	+	+	+	+	+	+	+	+	+	A	+	+	+	+	+	A	+	+	+	+	+
Liver	+	+	+	+	+	+	+	+	+	+	+	+	+	+	+	+	+	+	+	+	+	+	+	+	+	+	+	+
Fibrous histiocytoma, metastatic, skin																												
Sarcoma, metastatic, skin																												
X																												
Mesentery																												
+																												
Fibrous histiocytoma, metastatic, skin																												
X																												
Pancreas	+	+	+	+	+	+	+	+	+	+	+	+	+	+	+	+	+	+	+	+	+	+	+	+	+	+	+	+
Fibrous histiocytoma, metastatic, skin																												
X																												
Salivary glands	M	+	+	+	+	+	+	+	+	+	+	+	+	+	+	+	+	+	+	+	+	+	+	+	+	+	+	+
Stomach, forestomach	+	+	+	+	+	+	+	+	+	+	+	+	+	+	+	+	+	+	+	+	+	+	+	+	+	+	+	+
Stomach, glandular	+	+	+	+	+	+	+	+	+	+	+	+	+	+	+	+	+	+	+	+	+	+	+	+	+	+	+	+
Tooth																												
+																												
+																												
+																												
Cardiovascular System																												
Blood vessel	+	+	+	+	+	+	+	+	+	+	+	+	+	+	+	+	+	+	+	+	+	+	+	+	+	+	+	+
Heart	+	+	+	+	+	+	+	+	+	+	+	+	+	+	+	+	+	+	+	+	+	+	+	+	+	+	+	+
Sarcoma, metastatic, skin																												
X																												
Endocrine System																												
Adrenal cortex	+	+	+	+	+	+	+	+	+	+	+	+	+	+	+	+	+	+	+	+	+	+	+	+	+	+	+	+
Sarcoma, metastatic, skin																												
X																												
Adrenal medulla	+	+	+	+	+	+	+	+	+	+	+	+	+	+	+	+	+	+	+	+	+	+	+	+	+	+	+	+
Pheochromocytoma malignant																												
Pheochromocytoma benign																												
X																												
Islets, pancreatic	+	+	+	+	+	+	+	+	+	+	+	+	+	+	+	+	+	+	+	+	+	+	+	+	+	+	+	+
Adenoma																												
Carcinoma																												
Parathyroid gland	+	+	+	+	+	+	+	+	+	+	+	+	+	+	+	+	+	+	+	+	+	+	+	+	+	+	+	+
Pituitary gland	+	+	+	+	+	+	+	+	+	+	+	+	+	+	+	+	+	+	+	+	+	+	+	+	+	+	+	+
Pars distalis, adenoma		X	X			X	X		X	X	X	X	X	X	X	X	X	X	X	X	X	X	X	X	X	X	X	X
Thyroid gland	+	+	+	+	+	+	+	+	+	+	+	+	+	+	+	+	+	+	+	+	+	+	+	+	+	+	+	+
C-cell, adenoma																												
X																												
General Body System																												
None																												

+ : Tissue examined microscopically
 A : Autolysis precludes examination

M : Missing tissue
 I : Insufficient tissue

X : Lesion present
 Blank : Not examined

**TABLE A2
Individual Animal Tumor Pathology of Male Rats in the 2-Year Inhalation Study of Vanadium Pentoxide: 0.5 mg/m³**

Number of Days on Study	7	7	7	7	7	7	7	7	7	7	7	7	7	7	7	7	7	7	7	7	7	7	7			
	2	2	2	2	2	2	2	2	2	3	3	3	3	3	3	3	3	3	3	3	3	3	3			
	9	9	9	9	9	9	9	9	9	0	0	0	0	0	0	0	0	0	0	0	0	1	1	1	1	1
Carcass ID Number	2	2	2	2	2	2	2	2	2	2	2	2	2	2	2	2	2	2	2	2	2	2	2	2	2	Total Tissues/ Tumors
	2	3	3	3	3	3	3	4	4	0	0	1	1	1	2	2	2	4	4	4	0	0	1	3	4	
	5	0	1	4	7	8	9	1	4	1	6	2	3	7	1	7	9	0	6	7	5	7	0	6	9	
Alimentary System																										
Esophagus	+	+	+	+	+	+	+	+	+	+	+	+	+	+	+	+	+	+	+	+	+	+	+	+	+	50
Intestine large, colon	+	+	+	+	+	+	+	+	+	+	+	+	+	+	+	+	+	+	+	+	+	+	+	+	+	48
Intestine large, rectum	+	+	+	+	+	+	+	+	+	+	+	+	+	+	+	+	+	+	+	+	+	+	+	+	+	49
Intestine large, cecum	+	+	+	+	+	+	+	+	+	+	+	+	+	+	+	+	+	+	+	+	+	+	+	+	+	48
Intestine small, duodenum	+	+	+	+	+	+	+	+	+	+	+	+	+	+	+	+	+	+	+	+	+	+	+	+	+	49
Intestine small, jejunum	+	+	+	+	+	+	+	+	+	+	+	+	+	+	+	+	+	+	+	+	+	+	+	+	+	47
Intestine small, ileum	+	+	+	+	+	+	+	+	+	+	+	+	+	+	+	+	+	+	+	+	+	+	+	+	+	47
Liver	+	+	+	+	+	+	+	+	+	+	+	+	+	+	+	+	+	+	+	+	+	+	+	+	+	50
Hepatocellular adenoma																										1
X																										
Mesentery	+	+					+	+					+	+					+	+			+	+		18
Oral mucosa														+								+				3
Squamous cell papilloma																										1
X																										
Pharyngeal, squamous cell papilloma																										1
Pancreas	+	+	+	+	+	+	+	+	+	+	+	+	+	+	+	+	+	+	+	+	+	+	+	+	+	50
Salivary glands	+	+	+	+	+	+	+	+	+	+	+	+	+	+	+	+	+	+	+	+	+	+	+	+	+	50
Stomach, forestomach	+	+	+	+	+	+	+	+	+	+	+	+	+	+	+	+	+	+	+	+	+	+	+	+	+	50
Stomach, glandular	+	+	+	+	+	+	+	+	+	+	+	+	+	+	+	+	+	+	+	+	+	+	+	+	+	50
Tooth																										1
Cardiovascular System																										
Blood vessel	+	+	+	+	+	+	+	+	+	+	+	+	+	+	+	+	+	+	+	+	+	+	+	+	+	50
Heart	+	+	+	+	+	+	+	+	+	+	+	+	+	+	+	+	+	+	+	+	+	+	+	+	+	50
Carcinoma, metastatic, mammary gland																										1
X																										
Endocrine System																										
Adrenal cortex	+	+	+	+	+	+	+	+	+	+	+	+	+	+	+	+	+	+	+	+	+	+	+	+	+	50
Adrenal medulla	+	+	+	+	+	+	+	+	+	+	+	+	+	+	+	+	+	+	+	+	+	+	+	+	+	50
Pheochromocytoma malignant																										2
X																										
Pheochromocytoma benign																										10
Bilateral, pheochromocytoma benign	X			X							X	X		X	X			X							1	
Islets, pancreatic	+	+	+	+	+	+	+	+	+	+	+	+	+	+	+	+	+	+	+	+	+	+	+	+	+	50
Adenoma																							X			3
Carcinoma				X									X												X	4
Parathyroid gland	+	+	+	+	+	+	+	+	+	+	+	+	+	+	+	+	+	+	+	+	+	+	+	+	+	49
Pituitary gland	+	+	+	+	+	+	+	+	+	+	+	+	+	+	+	+	+	+	+	+	+	+	+	+	+	50
Pars distalis, adenoma	X		X	X	X	X	X	X	X	X	X	X	X	X	X	X	X	X	X	X	X	X	X	X	X	35
Thyroid gland	+	+	+	+	+	+	+	+	+	+	+	+	+	+	+	+	+	+	+	+	+	+	+	+	+	50
Sarcoma, metastatic, skin																										1
C-cell, adenoma																						X		X	X	4
General Body System																										
None																										

TABLE A2
Individual Animal Tumor Pathology of Male Rats in the 2-Year Inhalation Study of Vanadium Pentoxide: 0.5 mg/m³

Number of Days on Study	7 2 2 2 2 2 2 2 2 2 3 3 3 3 3 3 3 3 3 3 3 3 3 3 9 9 9 9 9 9 9 9 9 0 0 0 0 0 0 0 0 0 0 0 1 1 1 1 1	Carcass ID Number	2 3 3 3 3 3 3 4 4 0 0 1 1 1 2 2 2 4 4 4 0 0 1 3 4 5 0 1 4 7 8 9 1 4 1 6 2 3 7 1 7 9 0 6 7 5 7 0 6 9	Total Tissues/ Tumors
Genital System				
Epididymis	+		50	
Preputial gland	+		50	
Carcinoma			2	
Prostate	+		50	
Seminal vesicle	+		50	
Testes	+		50	
Bilateral, interstitial cell, adenoma	X	X	21	
Interstitial cell, adenoma		X	11	
Hematopoietic System				
Bone marrow	+		50	
Lymph node	+		3	
Lymph node, bronchial	M		44	
Lymph node, mandibular	M		48	
Lymph node, mesenteric	+		50	
Lymph node, mediastinal	M		47	
Spleen	+		50	
Thymus	+		49	
Integumentary System				
Mammary gland	+		50	
Carcinoma, multiple			1	
Fibroadenoma			2	
Skin	+		50	
Basal cell adenoma			1	
Basal cell adenoma, multiple			1	
Keratoacanthoma	X		6	
Squamous cell papilloma			1	
Subcutaneous tissue, sarcoma			1	
Musculoskeletal System				
Bone	+		50	
Femur, osteosarcoma			1	
Skeletal muscle			2	
Carcinoma, metastatic, mammary gland			1	
Nervous System				
Brain	+		50	
Glioma malignant			1	
Meningioma malignant			1	

TABLE A2
Individual Animal Tumor Pathology of Male Rats in the 2-Year Inhalation Study of Vanadium Pentoxide: 0.5 mg/m³

Number of Days on Study	7 7	
	2 2 2 2 2 2 2 2 2 2 3 3 3 3 3 3 3 3 3 3 3 3 3	
	9 9 9 9 9 9 9 9 9 9 0 0 0 0 0 0 0 0 0 0 1 1 1 1 1	
Carcass ID Number	2 2	Total Tissues/Tumors
	2 3 3 3 3 3 3 4 4 0 0 1 1 1 2 2 2 4 4 4 0 0 1 3 4	
	5 0 1 4 7 8 9 1 4 1 6 2 3 7 1 7 9 0 6 7 5 7 0 6 9	
Respiratory System		
Larynx	+ +	50
Lung	+ +	49
Alveolar/bronchiolar adenoma		6
Alveolar/bronchiolar adenoma, multiple	X	2
Alveolar/bronchiolar carcinoma		2
Alveolar/bronchiolar carcinoma, multiple		1
Carcinoma, metastatic, mammary gland		1
Osteosarcoma, metastatic, bone		1
Pheochromocytoma malignant, metastatic, adrenal medulla		1
Nose	+ +	50
Trachea	+ +	50
Special Senses System		
Eye		3
Urinary System		
Kidney	+ +	50
Renal tubule, carcinoma		1
Urinary bladder	+ +	50
Papilloma		1
Systemic Lesions		
Multiple organs	+ +	50
Leukemia mononuclear	X X	21
Lymphoma malignant		1

TABLE A2
Individual Animal Tumor Pathology of Male Rats in the 2-Year Inhalation Study of Vanadium Pentoxide: 1 mg/m³

Number of Days on Study	7 7	
	2 2 2 2 2 2 2 2 2 2 2 2 3 3 3 3 3 3 3 3 3 3 3	
	9 9 9 9 9 9 9 9 9 9 9 9 9 0 0 0 0 0 0 0 0 0 1 1 1	
Carcass ID Number	4 4	Total Tissues/ Tumors
	0 1 2 2 2 3 3 3 4 4 4 4 4 0 0 1 1 3 3 3 3 3 4 0 0 4	
	9 0 6 7 9 0 1 5 2 7 8 9 1 3 4 7 3 4 6 8 9 3 2 7 6	
Genital System		
Coagulating gland		1
Epididymis	+ +	49
Penis		3
Preputial gland	+ +	49
Carcinoma		2
Prostate	+ +	49
Seminal vesicle	+ +	49
Testes	+ +	50
Bilateral, interstitial cell, adenoma	X X	18
Interstitial cell, adenoma		16
Hematopoietic System		
Bone marrow	+ +	50
Lymph node		2
Lymph node, bronchial	+ + I + + + + + + + + I + + + + + + + + + + + + + + + +	47
Alveolar/bronchiolar carcinoma, metastatic, lung		1
Lymph node, mandibular	+ + M + + + + + + + + M + + + + + + + + + + + + + + + +	46
Lymph node, mesenteric	+ +	49
Lymph node, mediastinal	+ +	46
Alveolar/bronchiolar carcinoma, metastatic, lung		1
Spleen	+ +	48
Thymus	+ +	49
Thymoma benign		1
Integumentary System		
Mammary gland	+ +	49
Fibroadenoma		1
Skin	+ +	50
Basal cell adenoma		1
Basal cell carcinoma		1
Keratoacanthoma		2
Neural crest tumor, benign		1
Schwannoma benign		1
Subcutaneous tissue, fibroma	X X	4
Subcutaneous tissue, fibrosarcoma		1
Subcutaneous tissue, lipoma		3
Musculoskeletal System		
Bone	+ +	50
Skeletal muscle		2
Alveolar/bronchiolar carcinoma, metastatic, lung		1
Nervous System		
Brain	+ +	49
Peripheral nerve		1

TABLE A2
Individual Animal Tumor Pathology of Male Rats in the 2-Year Inhalation Study of Vanadium Pentoxide: 1 mg/m³

Number of Days on Study	7 7	
	2 2 2 2 2 2 2 2 2 2 2 2 3 3 3 3 3 3 3 3 3 3 3	
	9 9 9 9 9 9 9 9 9 9 9 9 0 0 0 0 0 0 0 0 0 0 0 1 1 1	
Carcass ID Number	4 4	Total Tissues/Tumors
	0 1 2 2 2 3 3 3 4 4 4 4 0 0 1 1 3 3 3 3 3 4 0 0 4	
	9 0 6 7 9 0 1 5 2 7 8 9 1 3 4 7 3 4 6 8 9 3 2 7 6	
Respiratory System		
Larynx	+ +	50
Lung	+ +	48
Alveolar/bronchiolar adenoma		5
Alveolar/bronchiolar carcinoma	X X	1
Alveolar/bronchiolar carcinoma, metastatic, lung		1
Nose	+ +	49
Pleura		2
Alveolar/bronchiolar carcinoma, metastatic, lung	X	1
Trachea	+ +	49
Special Senses System		
Eye		2
Zymbal's gland		1
Urinary System		
Kidney	+ +	49
Urethra		1
Urinary bladder	+ +	48
Systemic Lesions		
Multiple organs	+ +	50
Leukemia mononuclear		19
Mesothelioma malignant	X X	3

TABLE A2
Individual Animal Tumor Pathology of Male Rats in the 2-Year Inhalation Study of Vanadium Pentoxide: 2 mg/m³

Number of Days on Study	3	3	5	5	5	5	5	5	5	5	6	6	6	6	6	6	6	6	6	6	6	6	7	7	7	7
	3	9	3	3	4	5	5	6	7	1	2	2	3	3	4	6	7	8	8	8	9	1	2	2	2	
	2	0	3	8	2	2	8	1	8	6	3	9	1	6	2	1	5	4	5	7	5	2	3	9	9	
Carcass ID Number	6	6	6	6	6	6	6	6	6	6	6	6	6	6	6	6	6	6	6	6	6	6	6	6	6	
	0	0	1	4	2	1	0	2	4	4	4	2	1	1	3	1	2	3	5	2	0	2	0	0	1	
	2	7	0	9	0	5	6	7	6	7	2	9	7	9	4	8	6	0	0	4	3	2	9	5	1	
Special Senses System																										
Eye																										
Urinary System																										
Kidney	+	+	+	+	+	+	+	+	+	+	+	+	+	+	+	+	+	+	+	+	+	+	+	+	+	
Urinary bladder	+	+	+	+	+	+	+	+	+	+	+	+	+	+	+	+	+	+	+	+	+	+	+	+	+	
Papilloma																									X	
Systemic Lesions																										
Multiple organs	+	+	+	+	+	+	+	+	+	+	+	+	+	+	+	+	+	+	+	+	+	+	+	+	+	
Leukemia mononuclear						X			X			X	X	X					X		X	X		X		

TABLE A2
Individual Animal Tumor Pathology of Male Rats in the 2-Year Inhalation Study of Vanadium Pentoxide: 2 mg/m³

Number of Days on Study	7 7	
	2 2 2 2 2 2 2 2 3 3 3 3 3 3 3 3 3 3 3 3 3 3 3	
	9 9 9 9 9 9 9 9 0 0 0 0 0 0 0 0 0 0 0 0 0 0 0 1 1 1	
Carcass ID Number	6 6	Total Tissues/Tumors
	1 1 2 3 3 3 4 4 0 0 1 2 2 2 3 3 3 3 4 4 4 4 0 1 3	
	3 6 5 2 7 9 1 3 1 4 2 1 3 8 3 5 6 8 0 4 5 8 8 4 1	
Special Senses System		
Eye	+ +	3
Urinary System		
Kidney	+ +	50
Urinary bladder	+ +	50
Papilloma		1
Systemic Lesions		
Multiple organs	+ +	50
Leukemia mononuclear	X X X X X X X X	17

TABLE A3
Statistical Analysis of Primary Neoplasms in Male Rats in the 2-Year Inhalation Study of Vanadium Pentoxide

	Chamber Control	0.5 mg/m ³	1 mg/m ³	2 mg/m ³
Adrenal Medulla: Benign Pheochromocytoma				
Overall rate ^a	4/50 (8%)	11/50 (22%)	6/49 (12%)	6/50 (12%)
Adjusted rate ^b	10.0%	25.7%	13.9%	14.4%
Terminal rate ^c	3/20 (15%)	9/29 (31%)	4/26 (15%)	4/27 (15%)
First incidence (days)	652	694	653	533
Poly-3 test ^d	P=0.508N	P=0.054	P=0.417	P=0.392
Adrenal Medulla: Benign, Complex, or Malignant Pheochromocytoma				
Overall rate	5/50 (10%)	13/50 (26%)	8/49 (16%)	6/50 (12%)
Adjusted rate	12.4%	30.4%	18.2%	14.4%
Terminal rate	3/20 (15%)	10/29 (35%)	4/26 (15%)	4/27 (15%)
First incidence (days)	652	694	633	533
Poly-3 test	P=0.357N	P=0.040	P=0.334	P=0.525
Lung: Alveolar/bronchiolar Adenoma				
Overall rate	4/50 (8%)	8/49 (16%)	5/48 (10%)	6/50 (12%)
Adjusted rate	10.0%	18.7%	11.7%	14.2%
Terminal rate	4/20 (20%)	7/29 (24%)	3/26 (12%)	3/27 (11%)
First incidence (days)	729 (T)	608	694	558
Poly-3 test	P=0.500	P=0.209	P=0.547	P=0.405
Lung: Alveolar/bronchiolar Carcinoma				
Overall rate	0/50 (0%)	3/49 (6%)	1/48 (2%)	3/50 (6%)
Adjusted rate	0.0%	7.1%	2.3%	7.3%
Terminal rate	0/20 (0%)	2/29 (7%)	1/26 (4%)	3/27 (11%)
First incidence (days)	— ^e	652	729 (T)	729 (T)
Poly-3 test	P=0.177	P=0.130	P=0.514	P=0.123
Lung: Alveolar/bronchiolar Adenoma or Carcinoma				
Overall rate	4/50 (8%)	10/49 (20%)	6/48 (13%)	9/50 (18%)
Adjusted rate	10.0%	23.3%	14.0%	21.3%
Terminal rate	4/20 (20%)	8/29 (28%)	4/26 (15%)	6/27 (22%)
First incidence (days)	729 (T)	608	694	558
Poly-3 test	P=0.232	P=0.092	P=0.416	P=0.134
Pancreatic Islets: Adenoma				
Overall rate	1/50 (2%)	3/50 (6%)	1/49 (2%)	2/50 (4%)
Adjusted rate	2.5%	7.1%	2.3%	4.9%
Terminal rate	1/20 (5%)	3/29 (10%)	0/26 (0%)	2/27 (7%)
First incidence (days)	729 (T)	729 (T)	717	729 (T)
Poly-3 test	P=0.539	P=0.329	P=0.744N	P=0.510
Pancreatic Islets: Carcinoma				
Overall rate	1/50 (2%)	4/50 (8%)	3/49 (6%)	0/50 (0%)
Adjusted rate	2.5%	9.4%	7.0%	0.0%
Terminal rate	1/20 (5%)	3/29 (10%)	2/26 (8%)	0/27 (0%)
First incidence (days)	729 (T)	714	722	—
Poly-3 test	P=0.218N	P=0.199	P=0.332	P=0.494N
Pancreatic Islets: Adenoma or Carcinoma				
Overall rate	2/50 (4%)	7/50 (14%)	4/49 (8%)	2/50 (4%)
Adjusted rate	5.0%	16.4%	9.3%	4.9%
Terminal rate	2/20 (10%)	6/29 (21%)	2/26 (8%)	2/27 (7%)
First incidence (days)	729 (T)	714	717	729 (T)
Poly-3 test	P=0.319N	P=0.094	P=0.372	P=0.685N

TABLE A3
Statistical Analysis of Primary Neoplasms in Male Rats in the 2-Year Inhalation Study of Vanadium Pentoxide

	Chamber Control	0.5 mg/m ³	1 mg/m ³	2 mg/m ³
Pituitary Gland (Pars Distalis): Adenoma				
Overall rate	35/50 (70%)	35/50 (70%)	39/50 (78%)	32/50 (64%)
Adjusted rate	76.3%	77.5%	81.1%	70.1%
Terminal rate	14/20 (70%)	24/29 (83%)	20/26 (77%)	19/27 (70%)
First incidence (days)	477	485	519	332
Poly-3 test	P=0.263N	P=0.550	P=0.371	P=0.324N
Skin: Keratoacanthoma				
Overall rate	4/50 (8%)	6/50 (12%)	2/50 (4%)	2/50 (4%)
Adjusted rate	10.0%	14.0%	4.5%	4.8%
Terminal rate	3/20 (15%)	5/29 (17%)	0/26 (0%)	0/27 (0%)
First incidence (days)	666	673	655	552
Poly-3 test	P=0.136N	P=0.410	P=0.291N	P=0.319N
Skin: Squamous Cell Papilloma or Keratoacanthoma				
Overall rate	5/50 (10%)	7/50 (14%)	2/50 (4%)	2/50 (4%)
Adjusted rate	12.4%	16.4%	4.5%	4.8%
Terminal rate	3/20 (15%)	6/29 (21%)	0/26 (0%)	0/27 (0%)
First incidence (days)	666	673	655	552
Poly-3 test	P=0.068N	P=0.421	P=0.178N	P=0.201N
Skin: Squamous Cell Papilloma, Keratoacanthoma, Trichoepithelioma, Basal Cell Adenoma, or Basal Cell Carcinoma				
Overall rate	5/50 (10%)	8/50 (16%)	4/50 (8%)	4/50 (8%)
Adjusted rate	12.4%	18.7%	9.0%	9.6%
Terminal rate	3/20 (15%)	6/29 (21%)	2/26 (8%)	1/27 (4%)
First incidence (days)	666	673	655	552
Poly-3 test	P=0.254N	P=0.315	P=0.440N	P=0.476N
Skin (Subcutaneous Tissue): Lipoma				
Overall rate	2/50 (4%)	0/50 (0%)	3/50 (6%)	1/50 (2%)
Adjusted rate	5.0%	0.0%	6.8%	2.4%
Terminal rate	1/20 (5%)	0/29 (0%)	2/26 (8%)	1/27 (4%)
First incidence (days)	701	—	655	729 (T)
Poly-3 test	P=0.561N	P=0.223N	P=0.545	P=0.491N
Skin (Subcutaneous Tissue): Fibroma				
Overall rate	2/50 (4%)	0/50 (0%)	4/50 (8%)	2/50 (4%)
Adjusted rate	5.0%	0.0%	9.1%	4.9%
Terminal rate	1/20 (5%)	0/29 (0%)	3/26 (12%)	2/27 (7%)
First incidence (days)	624	—	722	729 (T)
Poly-3 test	P=0.396	P=0.224N	P=0.377	P=0.688N
Skin: Fibrous Histiocytoma, Fibrosarcoma, or Sarcoma				
Overall rate	4/50 (8%)	1/50 (2%)	1/50 (2%)	1/50 (2%)
Adjusted rate	9.8%	2.3%	2.3%	2.4%
Terminal rate	0/20 (0%)	0/29 (0%)	0/26 (0%)	0/27 (0%)
First incidence (days)	612	708	655	390
Poly-3 test	P=0.133N	P=0.166N	P=0.157N	P=0.171N
Skin: Fibroma, Fibrous Histiocytoma, Fibrosarcoma, or Sarcoma				
Overall rate	6/50 (12%)	1/50 (2%)	5/50 (10%)	3/50 (6%)
Adjusted rate	14.5%	2.3%	11.3%	7.2%
Terminal rate	1/20 (5%)	0/29 (0%)	3/26 (12%)	2/27 (7%)
First incidence (days)	612	708	655	390
Poly-3 test	P=0.341N	P=0.050N	P=0.455N	P=0.235N

TABLE A3
Statistical Analysis of Primary Neoplasms in Male Rats in the 2-Year Inhalation Study of Vanadium Pentoxide

	Chamber Control	0.5 mg/m ³	1 mg/m ³	2 mg/m ³
Testes: Adenoma				
Overall rate	36/50 (72%)	32/50 (64%)	34/50 (68%)	34/50 (68%)
Adjusted rate	78.7%	70.7%	74.5%	78.5%
Terminal rate	18/20 (90%)	21/29 (72%)	23/26 (89%)	25/27 (93%)
First incidence (days)	502	571	584	533
Poly-3 test	P=0.460	P=0.252N	P=0.402N	P=0.604N
Thyroid Gland (C-cell): Adenoma				
Overall rate	1/50 (2%)	4/50 (8%)	4/49 (8%)	2/50 (4%)
Adjusted rate	2.5%	9.3%	9.3%	4.9%
Terminal rate	0/20 (0%)	3/29 (10%)	2/26 (8%)	1/27 (4%)
First incidence (days)	638	652	712	684
Poly-3 test	P=0.532	P=0.198	P=0.199	P=0.508
Thyroid Gland (C-cell): Adenoma or Carcinoma				
Overall rate	1/50 (2%)	4/50 (8%)	5/49 (10%)	3/50 (6%)
Adjusted rate	2.5%	9.3%	11.5%	7.3%
Terminal rate	0/20 (0%)	3/29 (10%)	2/26 (8%)	2/27 (7%)
First incidence (days)	638	652	551	684
Poly-3 test	P=0.340	P=0.198	P=0.120	P=0.313
All Organs: Mononuclear Cell Leukemia				
Overall rate	22/50 (44%)	21/50 (42%)	19/50 (38%)	17/50 (34%)
Adjusted rate	47.8%	46.7%	41.0%	39.2%
Terminal rate	4/20 (20%)	13/29 (45%)	6/26 (23%)	9/27 (33%)
First incidence (days)	502	493	528	552
Poly-3 test	P=0.205N	P=0.543N	P=0.324N	P=0.271N
All Organs: Malignant Mesothelioma				
Overall rate	1/50 (2%)	0/50 (0%)	3/50 (6%)	0/50 (0%)
Adjusted rate	2.5%	0.0%	6.8%	0.0%
Terminal rate	0/20 (0%)	0/29 (0%)	2/26 (8%)	0/27 (0%)
First incidence (days)	650	—	712	—
Poly-3 test	P=0.505N	P=0.488N	P=0.338	P=0.496N
All Organs: Benign Neoplasms				
Overall rate	48/50 (96%)	47/50 (94%)	49/50 (98%)	46/50 (92%)
Adjusted rate	98.6%	99.0%	99.7%	95.1%
Terminal rate	20/20 (100%)	29/29 (100%)	26/26 (100%)	26/27 (96%)
First incidence (days)	477	485	519	332
Poly-3 test	P=0.104N	P=0.905	P=0.805	P=0.315N
All Organs: Malignant Neoplasms				
Overall rate	28/50 (56%)	31/50 (62%)	30/50 (60%)	24/50 (48%)
Adjusted rate	58.3%	64.8%	62.8%	53.3%
Terminal rate	5/20 (25%)	16/29 (55%)	13/26 (50%)	12/27 (44%)
First incidence (days)	373	311	528	390
Poly-3 test	P=0.284N	P=0.325	P=0.404	P=0.390N

TABLE A3
Statistical Analysis of Primary Neoplasms in Male Rats in the 2-Year Inhalation Study of Vanadium Pentoxide

	Chamber Control	0.5 mg/m ³	1 mg/m ³	2 mg/m ³
All Organs: Benign or Malignant Neoplasms				
Overall rate	50/50 (100%)	50/50 (100%)	49/50 (98%)	49/50 (98%)
Adjusted rate	100.0%	100.0%	99.7%	99.2%
Terminal rate	20/20 (100%)	29/29 (100%)	26/26 (100%)	27/27 (100%)
First incidence (days)	373	311 ^f	519	332
Poly-3 test	P=0.530N	—	P=1.000N	P=0.930N

(T) Terminal sacrifice

^a Number of neoplasm-bearing animals/number of animals examined. Denominator is number of animals examined microscopically for adrenal gland, lung, pancreatic islets, pituitary gland, testes, and thyroid gland; for other tissues, denominator is number of animals necropsied.

^b Poly-3 estimated neoplasm incidence after adjustment for intercurrent mortality

^c Observed incidence at terminal kill

^d Beneath the chamber control incidence is the P value associated with the trend test. Beneath the exposed group incidence are the P values corresponding to pairwise comparisons between the chamber controls and that exposed group. The Poly-3 test accounts for the differential mortality in animals that do not reach terminal sacrifice. A negative trend or a lower incidence in an exposure group is indicated by N.

^e Not applicable; no neoplasms in animal group

^f Value of statistic cannot be computed.

TABLE A4
Historical Incidence of Alveolar/bronchiolar Neoplasms in Control Male F344/N Rats

	Incidence in Controls		
	Adenoma	Carcinoma	Adenoma or Carcinoma
Historical Incidence in Controls Given NTP-2000 Diet^a			
Citral (feed)	3/100	0/100	3/100
<i>p,p'</i> -Dichlorodiphenyl sulfone (feed)	2/50	0/50	2/50
Indium phosphide (inhalation)	6/50	1/50	7/50
60-Hz Magnetic fields (whole body exposure)	3/100	0/100	3/100
Methacrylonitrile (gavage)	0/50	0/50	0/50
Naphthalene (inhalation)	2/49	0/49	2/49
<i>o</i> -Nitrotoluene (feed)	1/60	1/60	2/60
<i>p</i> -Nitrotoluene (feed)	1/50	0/50	1/50
Sodium nitrite (drinking water)	2/50	0/50	2/50
Vanadium pentoxide (inhalation)	4/50	0/50	4/50
Overall Historical Incidence in Controls Given NTP-2000 Diet			
Total (%)	24/609 (3.9%)	2/609 (0.3%)	26/609 (4.3%)
Mean ± standard deviation	4.2% ± 3.5%	0.4% ± 0.8%	4.5% ± 3.9%
Range	0%-12%	0%-2%	0%-14%
Historical Incidence in Chamber Controls Given NIH-07 Diet at Battelle Pacific Northwest Laboratories^b			
Acetonitrile	1/48	1/48	2/48
2-Butoxyethanol	1/50	0/50	1/50
Chloroprene	2/50	0/50	2/50
Cobalt sulfate heptahydrate	1/50	0/50	1/50
Furfuryl alcohol	0/50	0/50	0/50
Gallium arsenide	1/50	2/50	3/50
Glutaraldehyde	0/50	0/50	0/50
Hexachlorocyclopentadiene	5/50	0/50	5/50
Isobutene	2/50	0/50	2/50
Isobutyraldehyde	1/50	0/50	1/50
Isoprene	0/49	1/49	1/49
Molybdenum trioxide	0/50	0/50	0/50
Nitromethane	1/50	0/50	1/50
Ozone	1/50	1/50	2/50
Tetrafluoroethylene	0/50	0/50	0/50
Tetrahydrofuran	0/50	0/50	0/50
Overall Historical Incidence in Chamber Controls Given NIH-07 Diet			
Total (%)	18/1,054 (1.7%)	8/1,054 (0.8%)	26/1,054 (2.5%)
Mean ± standard deviation	1.7% ± 2.4%	0.8% ± 1.2%	2.5% ± 2.6%
Range	0%-10%	0%-4%	0%-10%

^a Data as of January 17, 2001

^b Data as of December 21, 1999

TABLE A5
Summary of the Incidence of Nonneoplastic Lesions in Male Rats in the 2-Year Inhalation Study of Vanadium Pentoxide^a

	Chamber Control	0.5 mg/m ³	1 mg/m ³	2 mg/m ³
Disposition Summary				
Animals initially in study	50	50	50	50
Moribund	25	17	18	13
Natural deaths	5	4	6	10
Survivors				
Terminal sacrifice	20	29	26	27
Animals examined microscopically	50	50	50	50
Alimentary System				
Intestine large, rectum	(47)	(49)	(47)	(48)
Thrombosis			1 (2%)	
Intestine small, duodenum	(47)	(49)	(46)	(48)
Inflammation, suppurative	1 (2%)			
Liver	(50)	(50)	(49)	(50)
Basophilic focus		1 (2%)		1 (2%)
Bile stasis				1 (2%)
Clear cell focus	3 (6%)	2 (4%)	1 (2%)	7 (14%)
Hepatodiaphragmatic nodule	5 (10%)	8 (16%)	7 (14%)	14 (28%)
Inflammation, granulomatous				2 (4%)
Mixed cell focus				1 (2%)
Thrombosis				1 (2%)
Vacuolization cytoplasmic	5 (10%)	4 (8%)	8 (16%)	5 (10%)
Bile duct, dilatation				1 (2%)
Bile duct, hyperplasia	11 (22%)	8 (16%)	8 (16%)	14 (28%)
Hepatocyte, degeneration, cystic		3 (6%)	2 (4%)	
Hepatocyte, necrosis		1 (2%)	1 (2%)	
Hepatocyte, regeneration	1 (2%)	1 (2%)	2 (4%)	
Portal, inflammation, chronic active	4 (8%)		1 (2%)	4 (8%)
Portal, pigmentation				3 (6%)
Serosa, inflammation, suppurative	1 (2%)			
Mesentery	(8)	(18)	(12)	(9)
Hemorrhage	1 (13%)	1 (6%)	1 (8%)	
Artery, inflammation				1 (11%)
Fat, hemorrhage		1 (6%)		
Fat, necrosis	7 (88%)	16 (89%)	9 (75%)	8 (89%)
Oral mucosa		(3)		(4)
Inflammation, suppurative				1 (25%)
Pharyngeal, hyperplasia, squamous				1 (25%)
Pharyngeal, ulcer				1 (25%)
Pancreas	(50)	(50)	(49)	(50)
Infiltration cellular, lipocyte				1 (2%)
Acinus, atrophy	3 (6%)		4 (8%)	1 (2%)
Acinus, hyperplasia				3 (6%)
Artery, inflammation				2 (4%)
Stomach, forestomach	(50)	(50)	(49)	(50)
Cyst				1 (2%)
Diverticulum	1 (2%)			2 (4%)
Hyperkeratosis	1 (2%)			
Inflammation, suppurative	1 (2%)	1 (2%)		1 (2%)
Necrosis				1 (2%)
Ulcer	3 (6%)	3 (6%)	4 (8%)	3 (6%)
Arteriole, necrosis		1 (2%)		
Epithelium, hyperplasia	1 (2%)		3 (6%)	2 (4%)

^a Number of animals examined microscopically at the site and the number of animals with lesion

TABLE A5
Summary of the Incidence of Nonneoplastic Lesions in Male Rats in the 2-Year Inhalation Study of Vanadium Pentoxide

	Chamber Control	0.5 mg/m ³	1 mg/m ³	2 mg/m ³
Alimentary System (continued)				
Stomach, glandular	(50)	(50)	(49)	(50)
Erosion	1 (2%)		1 (2%)	
Inflammation, suppurative	1 (2%)			
Necrosis	2 (4%)	1 (2%)	2 (4%)	1 (2%)
Tongue			(1)	(2)
Epithelium, hyperplasia			1 (100%)	1 (50%)
Tooth	(7)	(1)	(2)	(5)
Peridental tissue, inflammation, suppurative	7 (100%)	1 (100%)	2 (100%)	4 (80%)
Cardiovascular System				
Blood vessel	(49)	(50)	(49)	(50)
Aorta, thrombosis				1 (2%)
Heart	(50)	(50)	(49)	(50)
Cardiomyopathy	7 (14%)	7 (14%)	7 (14%)	7 (14%)
Atrium, thrombosis	2 (4%)		2 (4%)	
Pericardium, fibrosis			1 (2%)	
Valve, hemorrhage	1 (2%)			
Ventricle, hypertrophy	1 (2%)			
Endocrine System				
Adrenal cortex	(50)	(50)	(49)	(50)
Angiectasis		1 (2%)		
Hemorrhage				1 (2%)
Hyperplasia	1 (2%)			1 (2%)
Necrosis	1 (2%)			1 (2%)
Vacuolization, cytoplasmic	9 (18%)	5 (10%)	7 (14%)	5 (10%)
Adrenal medulla	(50)	(50)	(49)	(50)
Hyperplasia	16 (32%)	8 (16%)	12 (24%)	10 (20%)
Necrosis	1 (2%)			
Islets, pancreatic	(50)	(50)	(49)	(50)
Hyperplasia		1 (2%)	1 (2%)	1 (2%)
Pituitary gland	(50)	(50)	(50)	(50)
Angiectasis		1 (2%)		1 (2%)
Hemorrhage	3 (6%)	1 (2%)		1 (2%)
Pars distalis, hyperplasia	2 (4%)	5 (10%)	5 (10%)	4 (8%)
Thyroid gland	(50)	(50)	(49)	(50)
C-cell, hyperplasia	9 (18%)	4 (8%)	4 (8%)	7 (14%)
Follicular cell, hyperplasia			2 (4%)	
General Body System				
None				
Genital System				
Epididymis	(50)	(50)	(49)	(50)
Inflammation, granulomatous	1 (2%)			
Spermatocele			1 (2%)	
Penis	(2)		(3)	
Hyperplasia, squamous			1 (33%)	
Necrosis	1 (50%)		1 (33%)	

TABLE A5
Summary of the Incidence of Nonneoplastic Lesions in Male Rats in the 2-Year Inhalation Study of Vanadium Pentoxide

	Chamber Control	0.5 mg/m ³	1 mg/m ³	2 mg/m ³
Genital System (continued)				
Preputial gland	(50)	(50)	(49)	(50)
Hyperplasia	1 (2%)	1 (2%)		2 (4%)
Inflammation, chronic	3 (6%)		1 (2%)	
Prostate	(50)	(50)	(49)	(50)
Fibrosis	1 (2%)			
Hyperplasia	1 (2%)	2 (4%)	3 (6%)	
Inflammation, granulomatous			1 (2%)	
Inflammation, suppurative	12 (24%)	8 (16%)	8 (16%)	6 (12%)
Seminal vesicle	(50)	(50)	(49)	(50)
Hyperplasia			1 (2%)	
Inflammation, granulomatous				1 (2%)
Inflammation, suppurative			1 (2%)	2 (4%)
Testes	(50)	(50)	(50)	(50)
Inflammation, suppurative		1 (2%)		
Necrosis		1 (2%)		
Artery, inflammation			2 (4%)	
Germinal epithelium, atrophy	6 (12%)	6 (12%)	13 (26%)	10 (20%)
Interstitial cell, hyperplasia	2 (4%)	7 (14%)	5 (10%)	3 (6%)
Hematopoietic System				
Bone marrow	(50)	(50)	(50)	(50)
Hyperplasia, lymphoid		1 (2%)		1 (2%)
Myelofibrosis	1 (2%)			
Lymph node	(2)	(3)	(2)	(5)
Inflammation, granulomatous				1 (20%)
Pancreatic, pigmentation				1 (20%)
Lymph node, bronchial	(39)	(44)	(47)	(44)
Fibrosis		1 (2%)		
Pigmentation	8 (21%)	8 (18%)	3 (6%)	12 (27%)
Lymph node, mandibular	(44)	(48)	(46)	(45)
Ectasia			1 (2%)	
Hyperplasia, lymphoid				1 (2%)
Inflammation, acute		1 (2%)	1 (2%)	1 (2%)
Lymph node, mediastinal	(45)	(47)	(46)	(44)
Angiectasis				1 (2%)
Inflammation, granulomatous				2 (5%)
Pigmentation	17 (38%)	15 (32%)	17 (37%)	17 (39%)
Spleen	(50)	(50)	(48)	(50)
Accessory spleen	1 (2%)		1 (2%)	
Fibrosis	7 (14%)	16 (32%)	12 (25%)	11 (22%)
Hematopoietic cell proliferation	4 (8%)			
Hemorrhage	8 (16%)	4 (8%)	1 (2%)	
Necrosis		2 (4%)	1 (2%)	1 (2%)
Pigmentation	1 (2%)	1 (2%)		
Thymus	(49)	(49)	(49)	(50)
Hemorrhage				1 (2%)

TABLE A5
Summary of the Incidence of Nonneoplastic Lesions in Male Rats in the 2-Year Inhalation Study of Vanadium Pentoxide

	Chamber Control	0.5 mg/m ³	1 mg/m ³	2 mg/m ³
Integumentary System				
Mammary gland	(48)	(50)	(49)	(50)
Galactocele	2 (4%)	1 (2%)	5 (10%)	4 (8%)
Skin	(50)	(50)	(50)	(50)
Cyst	2 (4%)	1 (2%)	1 (2%)	6 (12%)
Cyst, multiple			1 (2%)	
Hyperkeratosis	4 (8%)	2 (4%)	3 (6%)	3 (6%)
Hyperplasia			1 (2%)	
Inflammation, acute			1 (2%)	
Ulcer			1 (2%)	
Hair follicle, atrophy				1 (2%)
Subcutaneous tissue, edema			1 (2%)	
Subcutaneous tissue, fibrosis			1 (2%)	
Subcutaneous tissue, inflammation, granulomatous	1 (2%)	1 (2%)		
Musculoskeletal System				
Bone	(50)	(50)	(50)	(50)
Vertebra, fracture	1 (2%)			
Nervous System				
Brain	(50)	(50)	(49)	(50)
Hemorrhage	5 (10%)	3 (6%)	2 (4%)	4 (8%)
Hydrocephalus		1 (2%)		
Necrosis	1 (2%)	1 (2%)		
Medulla, demyelination, focal		1 (2%)		
Respiratory System				
Larynx	(49)	(50)	(50)	(49)
Foreign body	3 (6%)	3 (6%)	2 (4%)	2 (4%)
Hyperkeratosis			1 (2%)	
Inflammation, chronic	3 (6%)	20 (40%)	17 (34%)	28 (57%)
Inflammation, suppurative	11 (22%)	3 (6%)	4 (8%)	13 (27%)
Respiratory epithelium, ulcer				1 (2%)
Respiratory epithelium, epiglottis, degeneration		22 (44%)	23 (46%)	33 (67%)
Respiratory epithelium, epiglottis, hyperplasia		18 (36%)	34 (68%)	32 (65%)
Respiratory epithelium, epiglottis, metaplasia, squamous		9 (18%)	16 (32%)	19 (39%)
Lung	(50)	(49)	(48)	(50)
Hemorrhage	5 (10%)	1 (2%)	2 (4%)	1 (2%)
Inflammation, chronic active	5 (10%)	8 (16%)	24 (50%)	42 (84%)
Inflammation, suppurative		2 (4%)		
Metaplasia				1 (2%)
Mineralization		2 (4%)		1 (2%)
Alveolar epithelium, hyperplasia	7 (14%)	24 (49%)	34 (71%)	49 (98%)
Alveolar epithelium, metaplasia, squamous	1 (2%)			21 (42%)
Alveolus, infiltration cellular, histiocyte	22 (44%)	40 (82%)	45 (94%)	50 (100%)
Alveolus, pigmentation	1 (2%)		2 (4%)	28 (56%)
Artery, mineralization				1 (2%)
Bronchiole, hyperplasia	3 (6%)	17 (35%)	31 (65%)	49 (98%)
Bronchiole, metaplasia, squamous				7 (14%)
Interstitial, edema			1 (2%)	
Interstitial, fibrosis	7 (14%)	7 (14%)	16 (33%)	38 (76%)
Mediastinum, hemorrhage				1 (2%)

TABLE A5
Summary of the Incidence of Nonneoplastic Lesions in Male Rats in the 2-Year Inhalation Study of Vanadium Pentoxide

	Chamber Control	0.5 mg/m ³	1 mg/m ³	2 mg/m ³
Respiratory System (continued)				
Nose	(49)	(50)	(49)	(48)
Foreign body	3 (6%)	5 (10%)	1 (2%)	1 (2%)
Inflammation, chronic	1 (2%)	1 (2%)		
Inflammation, suppurative	8 (16%)	7 (14%)	3 (6%)	11 (23%)
Goblet cell, respiratory epithelium, hyperplasia	4 (8%)	15 (30%)	12 (24%)	17 (35%)
Nasolacrimal duct, inflammation, suppurative	1 (2%)	2 (4%)		
Olfactory epithelium, degeneration, hyaline	9 (18%)	3 (6%)	1 (2%)	4 (8%)
Respiratory epithelium, degeneration, hyaline		1 (2%)		
Respiratory epithelium, hyperplasia	2 (4%)	1 (2%)	1 (2%)	3 (6%)
Respiratory epithelium, metaplasia, squamous		3 (6%)	1 (2%)	3 (6%)
Respiratory epithelium, mineralization	1 (2%)			
Pleura			(2)	(1)
Inflammation			1 (50%)	
Trachea	(50)	(50)	(49)	(50)
Foreign body		1 (2%)		
Inflammation, suppurative	1 (2%)			
Epithelium, degeneration				1 (2%)
Special Senses System				
Eye	(1)	(3)	(2)	(3)
Atrophy	1 (100%)	1 (33%)		1 (33%)
Lens, cataract		2 (67%)	1 (50%)	2 (67%)
Urinary System				
Kidney	(50)	(50)	(49)	(50)
Accumulation, hyaline droplet	1 (2%)			1 (2%)
Infarct		1 (2%)	1 (2%)	
Infiltration cellular, lipocyte			1 (2%)	
Nephropathy, chronic	37 (74%)	42 (84%)	46 (94%)	47 (94%)
Cortex, cyst	2 (4%)			
Pelvis, dilatation	1 (2%)			
Renal tubule, pigmentation	1 (2%)		1 (2%)	
Urethra			(1)	
Inflammation, suppurative			1 (100%)	
Urinary bladder	(49)	(50)	(48)	(50)
Calculus microscopic observation only		1 (2%)	1 (2%)	
Hemorrhage	1 (2%)		1 (2%)	
Inflammation				1 (2%)
Transitional epithelium, hyperplasia	2 (4%)		1 (2%)	1 (2%)

APPENDIX B
SUMMARY OF LESIONS IN FEMALE RATS
IN THE 2-YEAR INHALATION STUDY
OF VANADIUM PENTOXIDE

TABLE B1	Summary of the Incidence of Neoplasms in Female Rats in the 2-Year Inhalation Study of Vanadium Pentoxide	150
TABLE B2	Individual Animal Tumor Pathology of Female Rats in the 2-Year Inhalation Study of Vanadium Pentoxide	154
TABLE B3	Statistical Analysis of Primary Neoplasms in Female Rats in the 2-Year Inhalation Study of Vanadium Pentoxide	176
TABLE B4	Historical Incidence of Alveolar/bronchiolar Neoplasms in Control Female F344/N Rats	179
TABLE B5	Summary of the Incidence of Nonneoplastic Lesions in Female Rats in the 2-Year Inhalation Study of Vanadium Pentoxide	180

TABLE B1
Summary of the Incidence of Neoplasms in Female Rats in the 2-Year Inhalation Study of Vanadium Pentoxide^a

	Chamber Control	0.5 mg/m ³	1 mg/m ³	2 mg/m ³
Disposition Summary				
Animals initially in study	50	50	50	50
Moribund	14	20	17	15
Natural deaths	3	6	4	5
Survivors				
Terminal sacrifice	33	24	29	30
Animals examined microscopically	50	50	50	50
Alimentary System				
Intestine large, colon	(48)	(47)	(48)	(49)
Intestine small, duodenum	(48)	(47)	(48)	(49)
Histiocytic sarcoma			1 (2%)	
Liver	(50)	(50)	(50)	(50)
Hepatocellular adenoma	1 (2%)			
Mesentery	(9)	(20)	(22)	(15)
Histiocytic sarcoma			1 (5%)	
Oral mucosa		(1)	(1)	
Pharyngeal, squamous cell carcinoma			1 (100%)	
Pharyngeal, squamous cell papilloma		1 (100%)		
Pancreas	(50)	(50)	(49)	(50)
Histiocytic sarcoma			1 (2%)	
Salivary glands	(50)	(50)	(50)	(50)
Histiocytic sarcoma			1 (2%)	
Stomach, forestomach	(50)	(50)	(50)	(50)
Histiocytic sarcoma			1 (2%)	
Stomach, glandular	(50)	(50)	(50)	(50)
Histiocytic sarcoma			1 (2%)	
Tongue		(2)	(4)	(2)
Squamous cell carcinoma		1 (50%)		
Squamous cell papilloma		1 (50%)	1 (25%)	
Tooth	(3)	(2)	(2)	(1)
Odontoma			1 (50%)	
Cardiovascular System				
Heart	(50)	(50)	(50)	(50)
Carcinoma, metastatic, mammary gland	1 (2%)			
Histiocytic sarcoma			1 (2%)	
Endocrine System				
Adrenal cortex	(49)	(50)	(50)	(50)
Adrenal medulla	(49)	(50)	(50)	(50)
Pheochromocytoma malignant		1 (2%)		1 (2%)
Pheochromocytoma benign	2 (4%)	2 (4%)	1 (2%)	1 (2%)
Islets, pancreatic	(49)	(50)	(49)	(50)
Adenoma	1 (2%)	1 (2%)	1 (2%)	
Carcinoma	1 (2%)			
Pituitary gland	(49)	(50)	(49)	(50)
Pars distalis, adenoma	31 (63%)	29 (58%)	24 (49%)	30 (60%)

TABLE B1
Summary of the Incidence of Neoplasms in Female Rats in the 2-Year Inhalation Study of Vanadium Pentoxide

	Chamber Control	0.5 mg/m ³	1 mg/m ³	2 mg/m ³
Endocrine System (continued)				
Thyroid gland	(50)	(50)	(50)	(50)
Bilateral, C-cell, adenoma			1 (2%)	
C-cell, adenoma	2 (4%)	4 (8%)	3 (6%)	3 (6%)
C-cell, carcinoma	1 (2%)	1 (2%)		
Follicular cell, carcinoma	2 (4%)			
General Body System				
None				
Genital System				
Clitoral gland	(50)	(50)	(49)	(50)
Adenoma	2 (4%)		3 (6%)	
Carcinoma		1 (2%)	2 (4%)	3 (6%)
Histiocytic sarcoma			1 (2%)	
Ovary	(50)	(50)	(50)	(50)
Carcinoma		1 (2%)		
Granulosa cell tumor benign		1 (2%)		1 (2%)
Uterus	(50)	(50)	(50)	(50)
Histiocytic sarcoma	1 (2%)		1 (2%)	
Polyp stromal	6 (12%)	3 (6%)	7 (14%)	13 (26%)
Sarcoma stromal				1 (2%)
Hematopoietic System				
Bone marrow	(50)	(50)	(50)	(50)
Lymph node	(3)	(3)	(3)	(2)
Carcinoma, metastatic, mammary gland	1 (33%)			
Pancreatic, histiocytic sarcoma	1 (33%)			
Lymph node, bronchial	(42)	(45)	(44)	(44)
Histiocytic sarcoma			1 (2%)	
Lymph node, mandibular	(42)	(41)	(45)	(46)
Lymph node, mesenteric	(50)	(50)	(50)	(50)
Histiocytic sarcoma			1 (2%)	
Lymph node, mediastinal	(48)	(50)	(50)	(48)
Carcinoma, metastatic, thyroid gland	1 (2%)			
Histiocytic sarcoma			1 (2%)	
Spleen	(50)	(50)	(50)	(50)
Thymus	(49)	(50)	(50)	(50)
Histiocytic sarcoma			1 (2%)	
Integumentary System				
Mammary gland	(50)	(50)	(50)	(50)
Adenoma	1 (2%)			
Carcinoma	1 (2%)	2 (4%)	2 (4%)	3 (6%)
Carcinoma, multiple	1 (2%)			
Fibroadenoma	12 (24%)	9 (18%)	18 (36%)	18 (36%)
Fibroadenoma, multiple	4 (8%)	4 (8%)	2 (4%)	3 (6%)

TABLE B1
Summary of the Incidence of Neoplasms in Female Rats in the 2-Year Inhalation Study of Vanadium Pentoxide

	Chamber Control	0.5 mg/m ³	1 mg/m ³	2 mg/m ³
Integumentary System (continued)				
Skin	(50)	(50)	(50)	(50)
Fibrosarcoma		1 (2%)		
Keratoacanthoma, multiple		1 (2%)		
Schwannoma malignant			1 (2%)	
Pinna, neural crest tumor, benign		1 (2%)	1 (2%)	
Subcutaneous tissue, fibroma	1 (2%)		1 (2%)	1 (2%)
Subcutaneous tissue, histiocytic sarcoma			1 (2%)	
Musculoskeletal System				
Skeletal muscle	(2)	(2)		(2)
Rhabdomyosarcoma				1 (50%)
Nervous System				
Brain	(50)	(50)	(50)	(50)
Astrocytoma malignant		2 (4%)	2 (4%)	
Respiratory System				
Larynx	(50)	(49)	(49)	(50)
Histiocytic sarcoma			1 (2%)	
Lung	(49)	(49)	(50)	(50)
Alveolar/bronchiolar adenoma		3 (6%)	1 (2%)	
Alveolar/bronchiolar carcinoma				1 (2%)
Carcinoma, metastatic, clitoral gland				1 (2%)
Fibrosarcoma, metastatic, skin		1 (2%)		
Mediastinum, histiocytic sarcoma			1 (2%)	
Nose	(50)	(50)	(50)	(50)
Chondroma	1 (2%)			
Special Senses System				
None				
Urinary System				
Kidney	(50)	(50)	(49)	(50)
Histiocytic sarcoma			1 (2%)	
Urinary bladder	(50)	(50)	(50)	(50)
Histiocytic sarcoma			1 (2%)	
Papilloma				1 (2%)
Sarcoma stromal, metastatic, uterus				1 (2%)
Transitional epithelium, carcinoma	1 (2%)			
Systemic Lesions				
Multiple organs ^b	(50)	(50)	(50)	(50)
Histiocytic sarcoma	1 (2%)		1 (2%)	
Leukemia mononuclear	21 (42%)	23 (46%)	22 (44%)	15 (30%)

TABLE B1
Summary of the Incidence of Neoplasms in Female Rats in the 2-Year Inhalation Study of Vanadium Pentoxide

	Chamber Control	0.5 mg/m ³	1 mg/m ³	2 mg/m ³
Neoplasm Summary				
Total animals with primary neoplasms ^c	47	47	46	45
Total primary neoplasms	93	93	96	96
Total animals with benign neoplasms	41	39	41	39
Total benign neoplasms	64	59	64	71
Total animals with malignant neoplasms	28	29	27	22
Total malignant neoplasms	29	34	32	25
Total animals with metastatic neoplasms	2	1		2
Total metastatic neoplasms	3	1		2

^a Number of animals examined microscopically at the site and the number of animals with neoplasm

^b Number of animals with any tissue examined microscopically

^c Primary neoplasms: all neoplasms except metastatic neoplasms

**TABLE B2
Individual Animal Tumor Pathology of Female Rats in the 2-Year Inhalation Study of Vanadium Pentoxide:
Chamber Control**

Number of Days on Study	2	4	4	5	5	6	6	6	6	6	6	6	6	6	7	7	7	7	7	7	7	7	7	7	7				
	3	5	6	1	4	2	2	3	3	3	3	6	6	9	0	1	2	2	3	3	3	3	3	3	3				
	4	8	3	9	8	4	5	8	8	8	6	6	8	8	7	0	2	1	1	1	1	1	1	1	1				
Carcass ID Number	1	1	1	1	1	1	1	1	1	1	1	1	1	1	1	1	1	1	1	1	1	1	1	1	1				
	3	1	2	3	1	0	4	0	1	2	4	4	3	2	4	3	4	0	0	1	2	2	2	2	3				
	8	8	6	4	9	8	2	7	3	5	0	3	9	9	5	6	7	1	2	7	0	3	7	8	0				
Alimentary System																													
Esophagus	+	+	+	+	+	+	+	+	+	+	+	+	+	+	+	+	+	+	+	+	+	+	+	+	+	+	+		
Intestine large, colon	+	+	+	+	+	+	A	+	+	+	+	+	+	+	+	+	A	+	+	+	+	+	+	+	+	+	+	+	
Intestine large, rectum	+	+	+	+	+	+	A	+	+	+	+	+	+	+	+	+	A	+	+	+	+	+	+	+	+	+	+	+	
Intestine large, cecum	+	A	+	+	+	+	A	+	+	+	+	+	+	+	+	+	A	+	+	+	+	+	+	+	+	+	+	+	
Intestine small, duodenum	+	+	+	+	+	+	A	+	+	+	+	+	+	+	+	+	A	+	+	+	+	+	+	+	+	+	+	+	
Intestine small, jejunum	+	A	+	+	+	+	A	+	+	+	+	+	+	+	+	+	A	+	+	+	+	+	+	+	+	+	+	+	
Intestine small, ileum	+	A	+	+	+	+	A	+	+	+	+	+	+	+	+	+	A	+	+	+	+	+	+	+	+	+	+	+	
Liver	+	+	+	+	+	+	+	+	+	+	+	+	+	+	+	+	+	+	+	+	+	+	+	+	+	+	+	+	
Hepatocellular adenoma																													
Mesentery								+	+			+						+			+								
Pancreas	+	+	+	+	+	+	+	+	+	+	+	+	+	+	+	+	+	+	+	+	+	+	+	+	+	+	+	+	+
Salivary glands	+	+	+	+	+	+	+	+	+	+	+	+	+	+	+	+	+	+	+	+	+	+	+	+	+	+	+	+	+
Stomach, forestomach	+	+	+	+	+	+	+	+	+	+	+	+	+	+	+	+	+	+	+	+	+	+	+	+	+	+	+	+	+
Stomach, glandular	+	+	+	+	+	+	+	+	+	+	+	+	+	+	+	+	+	+	+	+	+	+	+	+	+	+	+	+	+
Tooth									+																				
Cardiovascular System																													
Blood vessel	+	+	+	+	+	+	+	+	+	+	+	+	+	+	+	+	+	+	+	+	+	+	+	+	+	+	+	+	+
Heart	+	+	+	+	+	+	+	+	+	+	+	+	+	+	+	+	+	+	+	+	+	+	+	+	+	+	+	+	+
Carcinoma, metastatic, mammary gland	X																												
Endocrine System																													
Adrenal cortex	+	+	+	+	+	+	+	+	+	+	+	+	+	+	+	+	A	+	+	+	+	+	+	+	+	+	+	+	+
Adrenal medulla	+	+	+	+	+	+	+	+	+	+	+	+	+	+	+	+	A	+	+	+	+	+	+	+	+	+	+	+	+
Pheochromocytoma benign																													
Islets, pancreatic	+	+	+	+	+	+	+	+	+	+	+	+	+	+	+	+	A	+	+	+	+	+	+	+	+	+	+	+	+
Adenoma																													
Carcinoma																													
Parathyroid gland	+	+	+	M	+	+	M	+	+	+	+	+	+	+	+	+	M	+	+	+	+	+	+	+	+	+	+	+	+
Pituitary gland	+	+	+	+	+	+	+	+	+	+	+	+	+	+	+	+	A	+	+	+	+	+	+	+	+	+	+	+	+
Pars distalis, adenoma		X			X			X	X				X	X								X	X	X	X	X	X	X	X
Thyroid gland	+	+	+	+	+	+	+	+	+	+	+	+	+	+	+	+	+	+	+	+	+	+	+	+	+	+	+	+	+
C-cell, adenoma																													
C-cell, carcinoma																													
Follicular cell, carcinoma								X																					
General Body System																													
Tissue NOS																													
Genital System																													
Clitoral gland	+	+	+	+	+	+	+	+	+	+	+	+	+	+	+	+	+	+	+	+	+	+	+	+	+	+	+	+	+
Adenoma																													
Ovary	+	+	+	+	+	+	+	+	+	+	+	+	+	+	+	+	+	+	+	+	+	+	+	+	+	+	+	+	+
Uterus	+	+	+	+	+	+	+	+	+	+	+	+	+	+	+	+	+	+	+	+	+	+	+	+	+	+	+	+	+
Histiocytic sarcoma																													
Polyp stromal																													

+: Tissue examined microscopically
A: Autolysis precludes examination
M: Missing tissue
I: Insufficient tissue
X: Lesion present
Blank: Not examined

TABLE B2
Individual Animal Tumor Pathology of Female Rats in the 2-Year Inhalation Study of Vanadium Pentoxide: Chamber Control

Number of Days on Study	7 7																				Total Tissues/Tumors					
	3 3																									
	1 1 1 1 2 2 2 2 2 2 2 2 2 2 2 2 3 3 3 3 3																									
Carcass ID Number	1	1	1	1	1	1	1	1	1	1	1	1	1	1	1	1	1	1	1	1	1					
	3	4	4	5	0	0	0	0	1	1	2	2	2	3	3	0	1	1	1	1	3	3	4	4	4	
	1	4	9	0	3	4	6	9	0	2	1	2	4	3	7	5	1	4	5	6	2	5	1	6	8	
Alimentary System																										
Esophagus	+	+	+	+	+	+	+	+	+	+	+	+	+	+	+	+	+	+	+	+	+	+	+	+	+	50
Intestine large, colon	+	+	+	+	+	+	+	+	+	+	+	+	+	+	+	+	+	+	+	+	+	+	+	+	+	48
Intestine large, rectum	+	+	+	+	+	+	+	+	+	+	+	+	+	+	+	+	+	+	+	+	+	+	+	+	+	48
Intestine large, cecum	+	+	+	+	+	+	+	+	+	+	+	+	+	+	+	+	+	+	+	+	+	+	+	+	+	47
Intestine small, duodenum	+	+	+	+	+	+	+	+	+	+	+	+	+	+	+	+	+	+	+	+	+	+	+	+	+	48
Intestine small, jejunum	+	+	+	+	+	+	+	+	+	+	+	+	+	+	+	+	+	+	+	+	+	+	+	+	+	47
Intestine small, ileum	+	+	+	+	+	+	+	+	+	+	+	+	+	+	+	+	+	+	+	+	+	+	+	+	+	47
Liver	+	+	+	+	+	+	+	+	+	+	+	+	+	+	+	+	+	+	+	+	+	+	+	+	+	50
Hepatocellular adenoma				X																						1
Mesentery							+																+	+		9
Pancreas	+	+	+	+	+	+	+	+	+	+	+	+	+	+	+	+	+	+	+	+	+	+	+	+	+	50
Salivary glands	+	+	+	+	+	+	+	+	+	+	+	+	+	+	+	+	+	+	+	+	+	+	+	+	+	50
Stomach, forestomach	+	+	+	+	+	+	+	+	+	+	+	+	+	+	+	+	+	+	+	+	+	+	+	+	+	50
Stomach, glandular	+	+	+	+	+	+	+	+	+	+	+	+	+	+	+	+	+	+	+	+	+	+	+	+	+	50
Tooth							+							+												3
Cardiovascular System																										
Blood vessel	+	+	+	+	+	+	+	+	+	+	+	+	+	+	+	+	+	+	+	+	+	+	+	+	+	50
Heart	+	+	+	+	+	+	+	+	+	+	+	+	+	+	+	+	+	+	+	+	+	+	+	+	+	50
Carcinoma, metastatic, mammary gland																										1
Endocrine System																										
Adrenal cortex	+	+	+	+	+	+	+	+	+	+	+	+	+	+	+	+	+	+	+	+	+	+	+	+	+	49
Adrenal medulla	+	+	+	+	+	+	+	+	+	+	+	+	+	+	+	+	+	+	+	+	+	+	+	+	+	49
Pheochromocytoma benign								X	X																	2
Islets, pancreatic	+	+	+	+	+	+	+	+	+	+	+	+	+	+	+	+	+	+	+	+	+	+	+	+	+	49
Adenoma							X																			1
Carcinoma														X												1
Parathyroid gland	+	+	+	+	+	+	+	+	+	+	M	M	+	+	+	+	+	+	+	+	+	+	+	+	+	45
Pituitary gland	+	+	+	+	+	+	+	+	+	+	+	+	+	+	+	+	+	+	+	+	+	+	+	+	+	49
Pars distalis, adenoma	X	X	X		X	X	X	X	X	X		X	X		X	X		X	X		X	X		X	X	31
Thyroid gland	+	+	+	+	+	+	+	+	+	+	+	+	+	+	+	+	+	+	+	+	+	+	+	+	+	50
C-cell, adenoma																										2
C-cell, carcinoma																										1
Follicular cell, carcinoma	X																									2
General Body System																										
Tissue NOS							+																			1
Genital System																										
Clitoral gland	+	+	+	+	+	+	+	+	+	+	+	+	+	+	+	+	+	+	+	+	+	+	+	+	+	50
Adenoma																										2
Ovary	+	+	+	+	+	+	+	+	+	+	+	+	+	+	+	+	+	+	+	+	+	+	+	+	+	50
Uterus	+	+	+	+	+	+	+	+	+	+	+	+	+	+	+	+	+	+	+	+	+	+	+	+	+	50
Histiocytic sarcoma																										1
Polyp stromal			X										X						X					X		6

TABLE B2
Individual Animal Tumor Pathology of Female Rats in the 2-Year Inhalation Study of Vanadium Pentoxide:
Chamber Control

Number of Days on Study	2	4	4	5	5	6	6	6	6	6	6	6	6	6	7	7	7	7	7	7	7	7	7	7	7	7	7	7	
	3	5	6	1	4	2	2	3	3	3	6	6	9	0	1	2	2	3	3	3	3	3	3	3	3	3	3	3	
	4	8	3	9	8	4	5	8	8	8	6	6	8	8	7	0	2	1	1	1	1	1	1	1	1	1	1	1	
Carcass ID Number	1	1	1	1	1	1	1	1	1	1	1	1	1	1	1	1	1	1	1	1	1	1	1	1	1	1	1	1	
	3	1	2	3	1	0	4	0	1	2	4	4	3	2	4	3	4	0	0	1	2	2	2	2	2	3	3	3	
	8	8	6	4	9	8	2	7	3	5	0	3	9	9	5	6	7	1	2	7	0	3	7	8	0	0	0	0	
Hematopoietic System																													
Bone marrow	+	+	+	+	+	+	+	+	+	+	+	+	+	+	+	+	+	+	+	+	+	+	+	+	+	+	+	+	
Lymph node	+																												
Carcinoma, metastatic, mammary gland	X																												
Pancreatic, histiocytic sarcoma																													
Lymph node, bronchial	M	+	+	+	M	+	I	+	+	+	M	+	+	+	+	+	+	+	+	+	+	+	+	+	+	+	+	+	
Lymph node, mandibular	+	+	+	+	+	+	M	M	+	+	+	+	+	+	+	+	M	+	+	M	+	+	+	+	+	+	+	+	
Lymph node, mesenteric	+	+	+	+	+	+	+	+	+	+	+	+	+	+	+	+	+	+	+	+	+	+	+	+	+	+	+	+	+
Lymph node, mediastinal	+	+	+	+	+	M	+	+	+	+	M	+	+	+	+	+	+	+	+	+	+	+	+	+	+	+	+	+	
Carcinoma, metastatic, thyroid gland																													
Spleen	+	+	+	+	+	+	+	+	+	+	+	+	+	+	+	+	+	+	+	+	+	+	+	+	+	+	+	+	
Thymus	+	+	+	+	M	+	+	+	+	+	+	+	+	+	+	+	+	+	+	+	+	+	+	+	+	+	+	+	
Integumentary System																													
Mammary gland	+	+	+	+	+	+	+	+	+	+	+	+	+	+	+	+	+	+	+	+	+	+	+	+	+	+	+	+	
Adenoma																													
Carcinoma																													
Carcinoma, multiple	X																												
Fibroadenoma		X																											
Fibroadenoma, multiple																													
Skin	+	+	+	+	+	+	+	+	+	+	+	+	+	+	+	+	+	+	+	+	+	+	+	+	+	+	+	+	
Subcutaneous tissue, fibroma																													
Musculoskeletal System																													
Bone	+	+	+	+	+	+	+	+	+	+	+	+	+	+	+	+	+	+	+	+	+	+	+	+	+	+	+	+	
Skeletal muscle																													
Nervous System																													
Brain	+	+	+	+	+	+	+	+	+	+	+	+	+	+	+	+	+	+	+	+	+	+	+	+	+	+	+	+	
Respiratory System																													
Larynx	+	+	+	+	+	+	+	+	+	+	+	+	+	+	+	+	+	+	+	+	+	+	+	+	+	+	+	+	
Lung	+	A	+	+	+	+	+	+	+	+	+	+	+	+	+	+	+	+	+	+	+	+	+	+	+	+	+	+	
Nose	+	+	+	+	+	+	+	+	+	+	+	+	+	+	+	+	+	+	+	+	+	+	+	+	+	+	+	+	
Chondroma																													
Pleura																													
Trachea	+	+	+	+	+	+	+	+	+	+	+	+	+	+	+	+	+	+	+	+	+	+	+	+	+	+	+	+	
Special Senses System																													
Eye																													

TABLE B2
Individual Animal Tumor Pathology of Female Rats in the 2-Year Inhalation Study of Vanadium Pentoxide: Chamber Control

Table with 28 columns representing individual animals and 2 rows per animal for 'Number of Days on Study' and 'Carcass ID Number'. It lists tumor findings for various systems: Hematopoietic, Integumentary, Musculoskeletal, Nervous, Respiratory, and Special Senses, with counts for each.

TABLE B2
Individual Animal Tumor Pathology of Female Rats in the 2-Year Inhalation Study of Vanadium Pentoxide:
Chamber Control

Number of Days on Study	7 3 1 1 1 1 2 2 2 2 2 2 2 2 2 2 2 2 3 3 3 3 3 3	Total Tissues/ Tumors
Carcass ID Number	1 3 4 4 5 0 0 0 0 1 1 2 2 2 3 3 0 1 1 1 1 3 3 4 4 4 1 4 9 0 3 4 6 9 0 2 1 2 4 3 7 5 1 4 5 6 2 5 1 6 8	
Urinary System		
Kidney	+ +	50
Urinary bladder	+ +	50
Transitional epithelium, carcinoma	X	1
Systemic Lesions		
Multiple organs	+ +	50
Histiocytic sarcoma		1
Leukemia mononuclear	X X X X X X X X	21

TABLE B2
Individual Animal Tumor Pathology of Female Rats in the 2-Year Inhalation Study of Vanadium Pentoxide: 0.5 mg/m³

Number of Days on Study	3	4	4	5	5	5	5	5	5	6	6	6	6	6	6	6	6	6	6	6	7	7	7	7	7	7	7	7
	6	0	9	3	4	7	7	8	0	1	3	5	6	6	7	9	9	9	0	0	1	1	1	1	1	1	1	1
	6	8	9	3	0	1	1	2	8	2	3	2	7	8	5	4	5	6	1	8	0	2	7	7	7	7	7	7
Carcass ID Number	3	3	3	3	3	3	3	3	3	3	3	3	3	3	3	3	3	3	3	3	3	3	3	3	3	3	3	3
	3	1	3	1	4	1	1	0	2	1	3	2	3	3	1	0	2	4	0	5	1	0	1	1	1	1	3	3
	7	8	2	0	6	4	9	5	0	1	6	2	0	1	2	6	1	5	7	0	7	3	3	5	5	5	5	5
Special Senses System																												
Ear																												
Urinary System																												
Kidney	+	+	+	+	+	+	+	+	+	+	+	+	+	+	+	+	+	+	+	+	+	+	+	+	+	+	+	+
Urinary bladder	+	+	+	+	+	+	+	+	+	+	+	+	+	+	+	+	+	+	+	+	+	+	+	+	+	+	+	+
Systemic Lesions																												
Multiple organs	+	+	+	+	+	+	+	+	+	+	+	+	+	+	+	+	+	+	+	+	+	+	+	+	+	+	+	+
Leukemia mononuclear	X	X						X	X	X	X				X	X	X			X	X			X	X	X		

TABLE B2
Individual Animal Tumor Pathology of Female Rats in the 2-Year Inhalation Study of Vanadium Pentoxide: 1 mg/m³

Number of Days on Study	7 7	
	3 3	
	1 1 1 1 1 2 2 2 2 2 2 2 3 3 3 3 3 3 3 3 3 3 3 3	
Carcass ID Number	5 5	Total Tissues/ Tumors
	1 1 2 3 4 0 0 1 2 2 4 5 0 0 1 1 1 2 2 3 3 3 3 4 4	
	5 6 2 9 2 1 3 9 8 9 4 0 4 6 0 1 7 5 6 1 2 6 8 0 8	
Genital System		
Clitoral gland	+ +	49
Adenoma	X	3
Carcinoma		2
Histiocytic sarcoma		1
Ovary	+ +	50
Uterus	+ +	50
Histiocytic sarcoma		1
Polyp stromal		7
Hematopoietic System		
Bone marrow	+ +	50
Lymph node		3
Lymph node, bronchial	+ + + + + + + + + + I + + + + + + I + + + + + + + + +	44
Histiocytic sarcoma		1
Lymph node, mandibular	+ M M + + + + +	45
Lymph node, mesenteric	+ +	50
Histiocytic sarcoma		1
Lymph node, mediastinal	+ +	50
Histiocytic sarcoma		1
Spleen	+ +	50
Thymus	+ +	50
Histiocytic sarcoma		1
Integumentary System		
Mammary gland	+ +	50
Carcinoma		2
Fibroadenoma		18
Fibroadenoma, multiple		2
Skin	+ +	50
Schwannoma malignant		1
Pinna, neural crest tumor, benign		1
Subcutaneous tissue, fibroma		1
Subcutaneous tissue, histiocytic sarcoma		1
Musculoskeletal System		
Bone	+ +	50
Nervous System		
Brain	+ +	50
Astrocytoma malignant		2

TABLE B2
Individual Animal Tumor Pathology of Female Rats in the 2-Year Inhalation Study of Vanadium Pentoxide: 1 mg/m³

Number of Days on Study	1	4	4	4	5	5	5	6	6	6	6	6	6	6	6	6	6	6	7	7	7	7	7	7	7	7	7	7	
	3	2	3	9	7	7	8	1	3	5	5	6	8	8	8	9	9	0	1	1	2	3	3	3	3	3	3	3	
	9	1	3	9	0	2	9	7	8	2	2	1	0	3	9	8	8	7	0	2	5	1	1	1	1	1	1	1	
Carcass ID Number	5	5	5	5	5	5	5	5	5	5	5	5	5	5	5	5	5	5	5	5	5	5	5	5	5	5	5	5	
	3	4	0	4	0	2	1	4	2	3	4	3	2	0	2	4	4	2	3	1	3	0	0	1	1	1	1	1	
	7	5	2	9	7	1	8	7	4	5	6	3	7	8	3	1	3	0	4	3	0	5	9	2	4	4	4	4	
Respiratory System																													
Larynx	+	+	A	+	+	+	+	+	+	+	+	+	+	+	+	+	+	+	+	+	+	+	+	+	+	+	+	+	
Histiocytic sarcoma													X																
Lung	+	+	+	+	+	+	+	+	+	+	+	+	+	+	+	+	+	+	+	+	+	+	+	+	+	+	+	+	
Alveolar/bronchiolar adenoma																													
Mediastinum, histiocytic sarcoma													X																
Nose	+	+	+	+	+	+	+	+	+	+	+	+	+	+	+	+	+	+	+	+	+	+	+	+	+	+	+	+	
Trachea	+	+	A	+	+	+	+	+	+	+	+	+	+	+	+	+	+	+	+	+	+	+	+	+	+	+	+	+	
Special Senses System																													
Eye	+																												
Harderian gland	+																												
Urinary System																													
Kidney	+	+	A	+	+	+	+	+	+	+	+	+	+	+	+	+	+	+	+	+	+	+	+	+	+	+	+	+	
Histiocytic sarcoma													X																
Urinary bladder	+	+	+	+	+	+	+	+	+	+	+	+	+	+	+	+	+	+	+	+	+	+	+	+	+	+	+	+	
Histiocytic sarcoma													X																
Systemic Lesions																													
Multiple organs	+	+	+	+	+	+	+	+	+	+	+	+	+	+	+	+	+	+	+	+	+	+	+	+	+	+	+	+	
Histiocytic sarcoma													X																
Leukemia mononuclear		X	X				X					X	X	X	X	X		X	X	X		X							

TABLE B2
Individual Animal Tumor Pathology of Female Rats in the 2-Year Inhalation Study of Vanadium Pentoxide: 1 mg/m³

Number of Days on Study	7 7	
	3 3	
	1 1 1 1 1 2 2 2 2 2 2 2 3 3 3 3 3 3 3 3 3 3 3	
Carcass ID Number	5 5	Total Tissues/ Tumors
	1 1 2 3 4 0 0 1 2 2 4 5 0 0 1 1 1 2 2 3 3 3 3 4 4	
	5 6 2 9 2 1 3 9 8 9 4 0 4 6 0 1 7 5 6 1 2 6 8 0 8	
Respiratory System		
Larynx	+ +	49
Histiocytic sarcoma		1
Lung	+ +	50
Alveolar/bronchiolar adenoma		1
Mediastinum, histiocytic sarcoma	X	1
Nose	+ +	50
Trachea	+ +	49
Special Senses System		
Eye		2
Harderian gland	+	1
Urinary System		
Kidney	+ +	49
Histiocytic sarcoma		1
Urinary bladder	+ +	50
Histiocytic sarcoma		1
Systemic Lesions		
Multiple organs	+ +	50
Histiocytic sarcoma		1
Leukemia mononuclear	X X X X X X X X X X X	22

TABLE B2
Individual Animal Tumor Pathology of Female Rats in the 2-Year Inhalation Study of Vanadium Pentoxide: 2 mg/m³

Number of Days on Study	3	4	4	5	5	5	5	6	6	6	6	6	6	6	6	6	7	7	7	7	7	7	7	7	7		
	3	4	5	1	6	8	9	1	1	3	3	4	5	6	8	9	0	1	1	2	3	3	3	3	3		
	2	0	5	4	9	9	7	2	7	6	8	7	3	8	0	4	6	5	7	5	1	1	1	1	1		
Carcass ID Number	7	7	7	7	7	7	7	7	7	7	7	7	7	7	7	7	7	7	7	7	7	7	7	7	7		
	2	0	2	3	0	3	2	0	4	4	0	1	4	1	3	4	4	1	1	3	0	0	0	2	2		
	3	8	9	5	2	3	4	5	9	4	4	1	7	4	1	8	3	6	5	7	1	6	7	0	2		
Hematopoietic System																											
Bone marrow	+	+	+	+	+	+	+	+	+	+	+	+	+	+	+	+	+	+	+	+	+	+	+	+	+	+	
Lymph node	+	+	+	+	+	M	+	+	+	i	+	M	+	+	+	+	+	+	+	M	+	+	+	M	I		
Lymph node, bronchial	+	+	+	+	+	+	+	+	+	+	+	+	+	+	+	+	M	+	+	+	+	+	+	+	+	M	
Lymph node, mandibular	+	+	+	+	+	+	+	+	+	+	+	+	+	+	+	+	+	+	+	+	+	+	+	+	+	+	
Lymph node, mesenteric	+	+	+	+	+	+	+	+	+	+	+	+	+	+	+	+	+	+	+	+	+	+	+	+	+	+	
Lymph node, mediastinal	+	+	+	+	+	+	+	+	+	+	+	+	+	M	+	+	+	+	+	+	+	+	i	+	+	+	
Spleen	+	+	+	+	+	+	+	+	+	+	+	+	+	+	+	+	+	+	+	+	+	+	+	+	+	+	
Thymus	+	+	+	+	+	+	+	+	+	+	+	+	+	+	+	+	+	+	+	+	+	+	+	+	+	+	
Integumentary System																											
Mammary gland	+	+	+	+	+	+	+	+	+	+	+	+	+	+	+	+	+	+	+	+	+	+	+	+	+	+	
Carcinoma														X									X				
Fibroadenoma									X		X			X								X		X			
Fibroadenoma, multiple																											
Skin	+	+	+	+	+	+	+	+	+	+	+	+	+	+	+	+	+	+	+	+	+	+	+	+	+	+	
Subcutaneous tissue, fibroma																											
Musculoskeletal System																											
Bone	+	+	+	+	+	+	+	+	+	+	+	+	+	+	+	+	+	+	+	+	+	+	+	+	+	+	
Skeletal muscle	+																										
Rhabdomyosarcoma	X																										
Nervous System																											
Brain	+	+	+	+	+	+	+	+	+	+	+	+	+	+	+	+	+	+	+	+	+	+	+	+	+	+	
Respiratory System																											
Larynx	+	+	+	+	+	+	+	+	+	+	+	+	+	+	+	+	+	+	+	+	+	+	+	+	+	+	
Lung	+	+	+	+	+	+	+	+	+	+	+	+	+	+	+	+	+	+	+	+	+	+	+	+	+	+	
Alveolar/bronchiolar carcinoma																											
Carcinoma, metastatic, clitoral gland									X																X		
Nose	+	+	+	+	+	+	+	+	+	+	+	+	+	+	+	+	+	+	+	+	+	+	+	+	+	+	
Trachea	+	+	+	+	+	+	+	+	+	+	+	+	+	+	+	+	+	+	+	+	+	+	+	+	+	+	
Special Senses System																											
Eye							+																			+	
Lacrimal gland																											
Urinary System																											
Kidney	+	+	+	+	+	+	+	+	+	+	+	+	+	+	+	+	+	+	+	+	+	+	+	+	+	+	
Urinary bladder	+	+	+	+	+	+	+	+	+	+	+	+	+	+	+	+	+	+	+	+	+	+	+	+	+	+	
Papilloma																									X		
Sarcoma stromal, metastatic, uterus									X																		
Systemic Lesions																											
Multiple organs	+	+	+	+	+	+	+	+	+	+	+	+	+	+	+	+	+	+	+	+	+	+	+	+	+	+	
Leukemia mononuclear					X	X	X	X									X	X	X	X							

TABLE B2
Individual Animal Tumor Pathology of Female Rats in the 2-Year Inhalation Study of Vanadium Pentoxide: 2 mg/m³

Number of Days on Study	7 7	3 3	1 1 2 2 2 2 2 2 2 2 2 2 2 2 2 2 2 3 3 3 3 3 3 3																							
Carcass ID Number	7 7	4 4 0 1 1 1 1 1 2 2 2 2 3 3 3 4 5 0 1 2 3 3 3 4 4	0 1 9 0 3 7 8 9 1 5 6 8 0 2 8 6 0 3 2 7 4 6 9 2 5																							
			Total Tissues/Tumors																							
Hematopoietic System																										
Bone marrow	+	+	+	+	+	+	+	+	+	+	+	+	+	+	+	+	+	+	+	+	+	+	+	+	50	
Lymph node																										2
Lymph node, bronchial	+	+	+	+	+	+	+	+	+	+	+	+	+	+	+	+	+	+	+	+	+	+	+	+	+	44
Lymph node, mandibular	+	+	+	+	M	M	+	+	+	+	+	+	+	+	+	+	+	+	+	+	+	+	+	+	+	46
Lymph node, mesenteric	+	+	+	+	+	+	+	+	+	+	+	+	+	+	+	+	+	+	+	+	+	+	+	+	+	50
Lymph node, mediastinal	+	+	+	+	+	+	+	+	+	+	+	+	+	+	+	+	+	+	+	+	+	+	+	+	+	48
Spleen	+	+	+	+	+	+	+	+	+	+	+	+	+	+	+	+	+	+	+	+	+	+	+	+	+	50
Thymus	+	+	+	+	+	+	+	+	+	+	+	+	+	+	+	+	+	+	+	+	+	+	+	+	+	50
Integumentary System																										
Mammary gland	+	+	+	+	+	+	+	+	+	+	+	+	+	+	+	+	+	+	+	+	+	+	+	+	+	50
Carcinoma																										3
Fibroadenoma				X	X			X	X	X	X	X	X	X	X	X	X	X	X	X	X	X	X	X	X	18
Fibroadenoma, multiple			X																							3
Skin	+	+	+	+	+	+	+	+	+	+	+	+	+	+	+	+	+	+	+	+	+	+	+	+	+	50
Subcutaneous tissue, fibroma				X																						1
Musculoskeletal System																										
Bone	+	+	+	+	+	+	+	+	+	+	+	+	+	+	+	+	+	+	+	+	+	+	+	+	+	50
Skeletal muscle																										2
Rhabdomyosarcoma																										1
Nervous System																										
Brain	+	+	+	+	+	+	+	+	+	+	+	+	+	+	+	+	+	+	+	+	+	+	+	+	+	50
Respiratory System																										
Larynx	+	+	+	+	+	+	+	+	+	+	+	+	+	+	+	+	+	+	+	+	+	+	+	+	+	50
Lung	+	+	+	+	+	+	+	+	+	+	+	+	+	+	+	+	+	+	+	+	+	+	+	+	+	50
Alveolar/bronchiolar carcinoma																										1
Carcinoma, metastatic, clitoral gland																										1
Nose	+	+	+	+	+	+	+	+	+	+	+	+	+	+	+	+	+	+	+	+	+	+	+	+	+	50
Trachea	+	+	+	+	+	+	+	+	+	+	+	+	+	+	+	+	+	+	+	+	+	+	+	+	+	50
Special Senses System																										
Eye																										3
Lacrimal gland																										1
Urinary System																										
Kidney	+	+	+	+	+	+	+	+	+	+	+	+	+	+	+	+	+	+	+	+	+	+	+	+	+	50
Urinary bladder	+	+	+	+	+	+	+	+	+	+	+	+	+	+	+	+	+	+	+	+	+	+	+	+	+	50
Papilloma																										1
Sarcoma stromal, metastatic, uterus																										1
Systemic Lesions																										
Multiple organs	+	+	+	+	+	+	+	+	+	+	+	+	+	+	+	+	+	+	+	+	+	+	+	+	+	50
Leukemia mononuclear	X	X					X						X	X					X			X				15

TABLE B3
Statistical Analysis of Primary Neoplasms in Female Rats in the 2-Year Inhalation Study of Vanadium Pentoxide

	Chamber Control	0.5 mg/m ³	1 mg/m ³	2 mg/m ³
Adrenal Medulla: Benign or Malignant Pheochromocytoma				
Overall rate ^a	2/49 (4%)	3/50 (6%)	1/50 (2%)	2/50 (4%)
Adjusted rate ^b	4.7%	7.1%	2.4%	4.7%
Terminal rate ^c	2/33 (6%)	0/24 (0%)	1/29 (3%)	1/30 (3%)
First incidence (days) ^d	731 (T)	571	731 (T)	706
Poly-3 test	P=0.501N	P=0.498	P=0.502N	P=0.693
Clitoral Gland: Adenoma				
Overall rate	2/50 (4%)	0/50 (0%)	3/49 (6%)	0/50 (0%)
Adjusted rate	4.6%	0.0%	7.1%	0.0%
Terminal rate	2/33 (6%)	0/24 (0%)	2/29 (7%)	0/30 (0%)
First incidence (days)	731 (T)	— ^e	698	—
Poly-3 test	P=0.296N	P=0.248N	P=0.484	P=0.243N
Clitoral Gland: Carcinoma				
Overall rate	0/50 (0%)	1/50 (2%)	2/49 (4%)	3/50 (6%)
Adjusted rate	0.0%	2.4%	4.8%	7.0%
Terminal rate	0/33 (0%)	0/24 (0%)	1/29 (3%)	2/30 (7%)
First incidence (days)	—	696	725	612
Poly-3 test	P=0.060	P=0.491	P=0.229	P=0.115
Clitoral Gland: Adenoma or Carcinoma				
Overall rate	2/50 (4%)	1/50 (2%)	5/49 (10%)	3/50 (6%)
Adjusted rate	4.6%	2.4%	11.8%	7.0%
Terminal rate	2/33 (6%)	0/24 (0%)	3/29 (10%)	2/30 (7%)
First incidence (days)	731 (T)	696	698	612
Poly-3 test	P=0.280	P=0.515N	P=0.201	P=0.492
Lung: Alveolar/bronchiolar Adenoma				
Overall rate	0/49 (0%)	3/49 (6%)	1/50 (2%)	0/50 (0%)
Adjusted rate	0.0%	7.3%	2.4%	0.0%
Terminal rate	0/33 (0%)	2/24 (8%)	1/29 (3%)	0/30 (0%)
First incidence (days)	—	675	731 (T)	— ^f
Poly-3 test	P=0.381N	P=0.108	P=0.496	—
Lung: Alveolar/bronchiolar Adenoma or Carcinoma				
Overall rate	0/49 (0%)	3/49 (6%)	1/50 (2%)	1/50 (2%)
Adjusted rate	0.0%	7.3%	2.4%	2.4%
Terminal rate	0/33 (0%)	2/24 (8%)	1/29 (3%)	1/30 (3%)
First incidence (days)	—	675	731 (T)	731 (T)
Poly-3 test	P=0.575	P=0.108	P=0.496	P=0.496
Mammary Gland: Fibroadenoma				
Overall rate	16/50 (32%)	13/50 (26%)	20/50 (40%)	21/50 (42%)
Adjusted rate	35.7%	30.2%	45.3%	48.4%
Terminal rate	13/33 (39%)	7/24 (29%)	13/29 (45%)	18/30 (60%)
First incidence (days)	458	608	570	617
Poly-3 test	P=0.065	P=0.372N	P=0.235	P=0.156
Mammary Gland: Fibroadenoma or Adenoma				
Overall rate	17/50 (34%)	13/50 (26%)	20/50 (40%)	21/50 (42%)
Adjusted rate	37.9%	30.2%	45.3%	48.4%
Terminal rate	14/33 (42%)	7/24 (29%)	13/29 (45%)	18/30 (60%)
First incidence (days)	458	608	570	617
Poly-3 test	P=0.092	P=0.293N	P=0.308	P=0.215

TABLE B3
Statistical Analysis of Primary Neoplasms in Female Rats in the 2-Year Inhalation Study of Vanadium Pentoxide

	Chamber Control	0.5 mg/m ³	1 mg/m ³	2 mg/m ³
Mammary Gland: Carcinoma				
Overall rate	2/50 (4%)	2/50 (4%)	2/50 (4%)	3/50 (6%)
Adjusted rate	4.5%	4.8%	4.7%	7.0%
Terminal rate	1/33 (3%)	1/24 (4%)	1/29 (3%)	2/30 (7%)
First incidence (days)	234	675	712	668
Poly-3 test	P=0.374	P=0.671	P=0.677	P=0.480
Mammary Gland: Adenoma or Carcinoma				
Overall rate	3/50 (6%)	2/50 (4%)	2/50 (4%)	3/50 (6%)
Adjusted rate	6.7%	4.8%	4.7%	7.0%
Terminal rate	2/33 (6%)	1/24 (4%)	1/29 (3%)	2/30 (7%)
First incidence (days)	234	675	712	668
Poly-3 test	P=0.533	P=0.529N	P=0.521N	P=0.642
Mammary Gland: Fibroadenoma, Adenoma, or Carcinoma				
Overall rate	19/50 (38%)	14/50 (28%)	22/50 (44%)	22/50 (44%)
Adjusted rate	41.5%	32.3%	49.8%	50.4%
Terminal rate	15/33 (46%)	7/24 (29%)	14/29 (48%)	18/30 (60%)
First incidence (days)	234	608	570	617
Poly-3 test	P=0.112	P=0.248N	P=0.278	P=0.260
Oral Cavity (Oral Mucosa, Tongue): Squamous Cell Papilloma or Squamous Cell Carcinoma				
Overall rate	0/50 (0%)	3/50 (6%)	2/50 (4%)	0/50 (0%)
Adjusted rate	0.0%	7.1%	4.6%	0.0%
Terminal rate	0/33 (0%)	1/24 (4%)	0/29 (0%)	0/30 (0%)
First incidence (days)	—	571	499	—
Poly-3 test	P=0.423N	P=0.113	P=0.236	—
Pituitary Gland (Pars Distalis): Adenoma				
Overall rate	31/49 (63%)	29/50 (58%)	24/49 (49%)	30/50 (60%)
Adjusted rate	68.1%	63.8%	55.1%	66.5%
Terminal rate	24/33 (73%)	15/24 (63%)	18/29 (62%)	19/30 (63%)
First incidence (days)	458	408	617	569
Poly-3 test	P=0.469N	P=0.411N	P=0.140N	P=0.525N
Thyroid Gland (C-cell): Adenoma				
Overall rate	2/50 (4%)	4/50 (8%)	4/50 (8%)	3/50 (6%)
Adjusted rate	4.5%	9.6%	9.3%	7.1%
Terminal rate	1/33 (3%)	3/24 (13%)	3/29 (10%)	2/30 (7%)
First incidence (days)	638	717	652	725
Poly-3 test	P=0.462	P=0.312	P=0.324	P=0.484
Thyroid Gland (C-cell): Adenoma or Carcinoma				
Overall rate	3/50 (6%)	5/50 (10%)	4/50 (8%)	3/50 (6%)
Adjusted rate	6.8%	12.0%	9.3%	7.1%
Terminal rate	1/33 (3%)	4/24 (17%)	3/29 (10%)	2/30 (7%)
First incidence (days)	625	717	652	725
Poly-3 test	P=0.504N	P=0.322	P=0.480	P=0.643
Uterus: Stromal Polyp				
Overall rate	6/50 (12%)	3/50 (6%)	7/50 (14%)	13/50 (26%)
Adjusted rate	13.6%	7.2%	15.9%	30.0%
Terminal rate	4/33 (12%)	1/24 (4%)	5/29 (17%)	8/30 (27%)
First incidence (days)	624	694	433	612
Poly-3 test	P=0.008	P=0.268N	P=0.497	P=0.051

TABLE B3
Statistical Analysis of Primary Neoplasms in Female Rats in the 2-Year Inhalation Study of Vanadium Pentoxide

	Chamber Control	0.5 mg/m ³	1 mg/m ³	2 mg/m ³
Uterus: Stromal Polyp or Stromal Sarcoma				
Overall rate	6/50 (12%)	3/50 (6%)	7/50 (14%)	14/50 (28%)
Adjusted rate	13.6%	7.2%	15.9%	32.0%
Terminal rate	4/33 (12%)	1/24 (4%)	5/29 (17%)	8/30 (27%)
First incidence (days)	624	694	433	569
Poly-3 test	P=0.004	P=0.268N	P=0.497	P=0.033
All Organs: Mononuclear Cell Leukemia				
Overall rate	21/50 (42%)	23/50 (46%)	22/50 (44%)	15/50 (30%)
Adjusted rate	45.2%	50.2%	47.8%	33.5%
Terminal rate	11/33 (33%)	8/24 (33%)	10/29 (35%)	8/30 (27%)
First incidence (days)	519	366	421	514
Poly-3 test	P=0.108N	P=0.391	P=0.483	P=0.175N
All Organs: Benign Neoplasms				
Overall rate	41/50 (82%)	39/50 (78%)	41/50 (82%)	39/50 (78%)
Adjusted rate	85.5%	82.2%	86.4%	84.8%
Terminal rate	29/33 (88%)	19/24 (79%)	25/29 (86%)	25/30 (83%)
First incidence (days)	458	408	433	569
Poly-3 test	P=0.522	P=0.437N	P=0.565	P=0.585N
All Organs: Malignant Neoplasms				
Overall rate	28/50 (56%)	29/50 (58%)	27/50 (54%)	22/50 (44%)
Adjusted rate	58.4%	62.1%	57.3%	46.9%
Terminal rate	14/33 (42%)	11/24 (46%)	12/29 (41%)	11/30 (37%)
First incidence (days)	234	366	421	332
Poly-3 test	P=0.104N	P=0.439	P=0.540N	P=0.177N
All Organs: Benign or Malignant Neoplasms				
Overall rate	47/50 (94%)	47/50 (94%)	46/50 (92%)	45/50 (90%)
Adjusted rate	94.0%	95.0%	93.9%	92.9%
Terminal rate	30/33 (91%)	22/24 (92%)	26/29 (90%)	27/30 (90%)
First incidence (days)	234	366	421	332
Poly-3 test	P=0.448N	P=0.589	P=0.651N	P=0.572N

(T) Terminal sacrifice

^a Number of neoplasm-bearing animals/number of animals examined. Denominator is number of animals examined microscopically for adrenal gland, clitoral gland, lung, pituitary gland, and thyroid gland; for other tissues, denominator is number of animals necropsied.

^b Poly-3 estimated neoplasm incidence after adjustment for intercurrent mortality

^c Observed incidence at terminal kill

^d Beneath the chamber control incidence is the P value associated with the trend test. Beneath the exposed group incidence are the P values corresponding to pairwise comparisons between the chamber controls and that exposed group. The Poly-3 test accounts for the differential mortality in animals that do not reach terminal sacrifice. A negative trend or a lower incidence in an exposure group is indicated by N.

^e Not applicable; no neoplasms in animal group

^f Value of statistic cannot be computed.

TABLE B4
Historical Incidence of Alveolar/bronchiolar Neoplasms in Control Female F344/N Rats

	Incidence in Controls		
	Adenoma	Carcinoma	Adenoma or Carcinoma
Historical Incidence in Controls Given NTP-2000 Diet^a			
Citral (feed)	2/100	1/100	3/100
<i>p,p'</i> -Dichlorodiphenyl sulfone (feed)	0/50	0/50	0/50
Indium phosphide (inhalation)	0/50	1/50	1/50
60-Hz Magnetic fields (whole body exposure)	3/100	1/100	4/100
Methacrylonitrile (gavage)	0/50	0/50	0/50
Naphthalene (inhalation)	1/49	0/49	1/49
<i>o</i> -Nitrotoluene (feed)	1/60	0/60	1/60
<i>p</i> -Nitrotoluene (feed)	0/50	0/50	0/50
Riddelliine (gavage)	2/50	0/50	2/50
Sodium nitrite (drinking water)	3/50	0/50	3/50
Vanadium pentoxide (inhalation)	0/49	0/49	0/49
Overall Historical Incidence in Controls Given NTP-2000 Diet			
Total (%)	12/658 (1.8%)	3/658 (0.5%)	15/658 (2.3%)
Mean ± standard deviation	1.7% ± 2.0%	0.4% ± 0.7%	2.1% ± 2.0%
Range	0%-6%	0%-2%	0%-6%
Historical Incidence in Chamber Controls Given NIH-07 Diet at Battelle Pacific Northwest Laboratories^b			
Acetonitrile	0/48	0/48	0/48
2-Butoxyethanol	0/50	0/50	0/50
Chloroprene	1/49	0/49	1/49
Cobalt sulfate heptahydrate	0/50	0/50	0/50
Furfuryl alcohol	1/50	0/50	1/50
Gallium arsenide	0/50	0/50	0/50
Glutaraldehyde	0/50	0/50	0/50
Hexachlorocyclopentadiene	1/50	0/50	1/50
Isobutene	2/50	0/50	2/50
Isobutyraldehyde	1/49	1/49	2/49
Isoprene	1/50	0/50	1/50
Molybdenum trioxide	0/50	0/50	0/50
Nitromethane	0/50	1/50	1/50
Ozone	0/50	0/50	0/50
Tetrafluoroethylene	0/50	0/50	0/50
Tetrahydrofuran	1/50	0/50	1/50
Overall Historical Incidence in Chamber Controls Given NIH-07 Diet			
Total (%)	12/1,050 (1.1%)	2/1,050 (0.2%)	14/1,050 (1.3%)
Mean ± standard deviation	1.1% ± 1.3%	0.2% ± 0.6%	1.3% ± 1.5%
Range	0%-4%	0%-2%	0%-4%

^a Data as of January 17, 2001

^b Data as of December 21, 1999

TABLE B5
Summary of the Incidence of Nonneoplastic Lesions in Female Rats in the 2-Year Inhalation Study of Vanadium Pentoxide^a

	Chamber Control	0.5 mg/m ³	1 mg/m ³	2 mg/m ³
Disposition Summary				
Animals initially in study	50	50	50	50
Moribund	14	20	17	15
Natural deaths	3	6	4	5
Survivors				
Terminal sacrifice	33	24	29	30
Animals examined microscopically	50	50	50	50
Alimentary System				
Esophagus	(50)	(50)	(50)	(50)
Periesophageal tissue, inflammation, chronic active	1 (2%)			
Liver	(50)	(50)	(50)	(50)
Angiectasis	1 (2%)	1 (2%)		2 (4%)
Basophilic focus	2 (4%)			
Basophilic focus, multiple		2 (4%)	2 (4%)	
Bile stasis	1 (2%)			
Clear cell focus	1 (2%)	4 (8%)	7 (14%)	4 (8%)
Clear cell focus, multiple			2 (4%)	1 (2%)
Hepatodiaphragmatic nodule	9 (18%)	9 (18%)	10 (20%)	13 (26%)
Inflammation, granulomatous		1 (2%)		
Vacuolization cytoplasmic	6 (12%)	8 (16%)	5 (10%)	7 (14%)
Bile duct, dilatation				1 (2%)
Bile duct, hyperplasia	1 (2%)	2 (4%)	1 (2%)	1 (2%)
Hepatocyte, degeneration, cystic				1 (2%)
Hepatocyte, necrosis			1 (2%)	1 (2%)
Hepatocyte, regeneration	1 (2%)			
Portal, inflammation, chronic active				1 (2%)
Portal, pigmentation		2 (4%)		1 (2%)
Serosa, fibrosis			1 (2%)	1 (2%)
Mesentery	(9)	(20)	(22)	(15)
Hemorrhage			1 (5%)	
Artery, inflammation	1 (11%)			
Fat, necrosis	9 (100%)	20 (100%)	17 (77%)	15 (100%)
Pancreas	(50)	(50)	(49)	(50)
Acinus, atrophy	2 (4%)		1 (2%)	
Stomach, forestomach	(50)	(50)	(50)	(50)
Erosion			1 (2%)	
Hyperkeratosis				1 (2%)
Inflammation, suppurative	1 (2%)			2 (4%)
Ulcer	5 (10%)	5 (10%)	1 (2%)	1 (2%)
Epithelium, hyperplasia			2 (4%)	2 (4%)
Stomach, glandular	(50)	(50)	(50)	(50)
Cyst	1 (2%)			
Erosion	1 (2%)		1 (2%)	
Inflammation, suppurative	1 (2%)			
Epithelium, hyperplasia				1 (2%)
Tongue		(2)	(4)	(2)
Epithelium, hyperkeratosis			3 (75%)	
Epithelium, hyperplasia				2 (100%)
Tooth	(3)	(2)	(2)	(1)
Peridontal tissue, inflammation, suppurative	3 (100%)	1 (50%)	1 (50%)	1 (100%)

^a Number of animals examined microscopically at the site and the number of animals with lesion

TABLE B5
Summary of the Incidence of Nonneoplastic Lesions in Female Rats in the 2-Year Inhalation Study of Vanadium Pentoxide

	Chamber Control	0.5 mg/m ³	1 mg/m ³	2 mg/m ³
Cardiovascular System				
Blood vessel	(50)	(50)	(50)	(50)
Inflammation	1 (2%)			
Mineralization		1 (2%)		
Heart	(50)	(50)	(50)	(50)
Cardiomyopathy	3 (6%)	1 (2%)	1 (2%)	2 (4%)
Ventricle, thrombosis		1 (2%)		
Endocrine System				
Adrenal cortex	(49)	(50)	(50)	(50)
Hyperplasia	1 (2%)	1 (2%)		1 (2%)
Necrosis		2 (4%)	1 (2%)	1 (2%)
Vacuolization cytoplasmic	9 (18%)	7 (14%)	4 (8%)	3 (6%)
Adrenal medulla	(49)	(50)	(50)	(50)
Angiectasis		1 (2%)		
Hyperplasia	2 (4%)	2 (4%)	1 (2%)	5 (10%)
Necrosis				1 (2%)
Islets, pancreatic	(49)	(50)	(49)	(50)
Hyperplasia	1 (2%)			1 (2%)
Parathyroid gland	(45)	(47)	(49)	(50)
Hyperplasia		1 (2%)		
Pituitary gland	(49)	(50)	(49)	(50)
Angiectasis		1 (2%)		
Cyst	4 (8%)	3 (6%)	1 (2%)	3 (6%)
Hemorrhage	1 (2%)		3 (6%)	
Pigmentation		1 (2%)		
Pars distalis, cyst				1 (2%)
Pars distalis, hyperplasia	12 (24%)	6 (12%)	16 (33%)	4 (8%)
Thyroid gland	(50)	(50)	(50)	(50)
C-cell, hyperplasia	6 (12%)	5 (10%)	2 (4%)	5 (10%)
Follicular cell, hyperplasia			1 (2%)	
General Body System				
None				
Genital System				
Clitoral gland	(50)	(50)	(49)	(50)
Cyst	1 (2%)	3 (6%)	1 (2%)	1 (2%)
Hyperplasia	2 (4%)	3 (6%)		2 (4%)
Inflammation, chronic				1 (2%)
Ovary	(50)	(50)	(50)	(50)
Atrophy	1 (2%)		1 (2%)	
Cyst	4 (8%)	10 (20%)	7 (14%)	12 (24%)
Inflammation, chronic		1 (2%)		1 (2%)
Inflammation, granulomatous		1 (2%)		
Follicle, cyst	2 (4%)	1 (2%)	1 (2%)	
Granulosa cell, hyperplasia				1 (2%)
Uterus	(50)	(50)	(50)	(50)
Hydrometra	1 (2%)			
Necrosis			1 (2%)	
Endometrium, hyperplasia		1 (2%)	4 (8%)	4 (8%)

TABLE B5
Summary of the Incidence of Nonneoplastic Lesions in Female Rats in the 2-Year Inhalation Study of Vanadium Pentoxide

	Chamber Control	0.5 mg/m ³	1 mg/m ³	2 mg/m ³
Hematopoietic System				
Bone marrow	(50)	(50)	(50)	(50)
Hyperplasia, megakaryocyte	1 (2%)			
Myelofibrosis		1 (2%)	1 (2%)	
Lymph node	(3)	(3)	(3)	(2)
Iliac, ectasia				1 (50%)
Pancreatic, pigmentation		1 (33%)		
Lymph node, bronchial	(42)	(45)	(44)	(44)
Pigmentation	16 (38%)	6 (13%)	8 (18%)	5 (11%)
Lymph node, mesenteric	(50)	(50)	(50)	(50)
Fibrosis			1 (2%)	
Hemorrhage	1 (2%)			
Lymph node, mediastinal	(48)	(50)	(50)	(48)
Angiectasis		1 (2%)		
Hyperplasia, lymphoid		1 (2%)		
Pigmentation	26 (54%)	14 (28%)	20 (40%)	24 (50%)
Spleen	(50)	(50)	(50)	(50)
Accessory spleen	3 (6%)	1 (2%)		
Fibrosis	2 (4%)	3 (6%)	1 (2%)	
Hematopoietic cell proliferation	1 (2%)			2 (4%)
Hemorrhage		3 (6%)		
Necrosis			1 (2%)	1 (2%)
Integumentary System				
Mammary gland	(50)	(50)	(50)	(50)
Galactocele	5 (10%)	2 (4%)	4 (8%)	6 (12%)
Epithelium, hyperplasia	3 (6%)			
Skin	(50)	(50)	(50)	(50)
Cyst		1 (2%)		1 (2%)
Hyperkeratosis			1 (2%)	
Inflammation, acute		1 (2%)		
Inflammation, chronic				1 (2%)
Inflammation, suppurative	1 (2%)			
Ulcer		1 (2%)	1 (2%)	1 (2%)
Hair follicle, atrophy				1 (2%)
Musculoskeletal System				
Bone	(50)	(50)	(50)	(50)
Hyperostosis		1 (2%)		1 (2%)
Skeletal muscle	(2)	(2)		(2)
Degeneration		1 (50%)		
Fibrosis		1 (50%)		
Inflammation, chronic active	1 (50%)			
Nervous System				
Brain	(50)	(50)	(50)	(50)
Compression	1 (2%)			1 (2%)
Hemorrhage	3 (6%)	6 (12%)	3 (6%)	
Thrombosis				1 (2%)

TABLE B5
Summary of the Incidence of Nonneoplastic Lesions in Female Rats in the 2-Year Inhalation Study of Vanadium Pentoxide

	Chamber Control	0.5 mg/m ³	1 mg/m ³	2 mg/m ³
Respiratory System				
Larynx	(50)	(49)	(49)	(50)
Foreign body	3 (6%)	6 (12%)		1 (2%)
Hemorrhage			1 (2%)	1 (2%)
Inflammation, chronic	8 (16%)	26 (53%)	27 (55%)	37 (74%)
Inflammation, suppurative	5 (10%)	2 (4%)	3 (6%)	2 (4%)
Ulcer				1 (2%)
Respiratory epithelium, epiglottis, degeneration	2 (4%)	33 (67%)	26 (53%)	40 (80%)
Respiratory epithelium, epiglottis, hyperplasia		25 (51%)	26 (53%)	33 (66%)
Respiratory epithelium, epiglottis, metaplasia, squamous	2 (4%)	7 (14%)	7 (14%)	16 (32%)
Lung	(49)	(49)	(50)	(50)
Edema	1 (2%)			
Hemorrhage	1 (2%)	1 (2%)		
Inflammation				1 (2%)
Inflammation, chronic active	10 (20%)	10 (20%)	14 (28%)	40 (80%)
Inflammation, suppurative	2 (4%)			
Alveolar epithelium, hyperplasia	4 (8%)	8 (16%)	21 (42%)	50 (100%)
Alveolar epithelium, metaplasia, squamous				6 (12%)
Alveolar epithelium, regeneration				1 (2%)
Alveolus, infiltration cellular, histiocyte	26 (53%)	35 (71%)	44 (88%)	50 (100%)
Alveolus, pigmentation	1 (2%)	1 (2%)	8 (16%)	7 (14%)
Artery, mineralization	1 (2%)			
Bronchiole, foreign body	1 (2%)			
Bronchiole, hyperplasia	6 (12%)	5 (10%)	14 (28%)	48 (96%)
Bronchiole, inflammation, suppurative	1 (2%)			
Bronchiole, metaplasia, squamous				1 (2%)
Interstitial, fibrosis	19 (39%)	7 (14%)	12 (24%)	32 (64%)
Nose	(50)	(50)	(50)	(50)
Foreign body	3 (6%)	4 (8%)	1 (2%)	2 (4%)
Inflammation, chronic	1 (2%)			
Inflammation, suppurative	3 (6%)	6 (12%)	5 (10%)	10 (20%)
Goblet cell, respiratory epithelium, hyperplasia	13 (26%)	18 (36%)	16 (32%)	30 (60%)
Nasolacrimal duct, inflammation, suppurative	2 (4%)	4 (8%)	2 (4%)	7 (14%)
Olfactory epithelium, degeneration, hyaline	16 (32%)	20 (40%)	6 (12%)	4 (8%)
Respiratory epithelium, hyperplasia	1 (2%)	2 (4%)	1 (2%)	2 (4%)
Respiratory epithelium, metaplasia, squamous			2 (4%)	1 (2%)
Respiratory epithelium, ulcer				1 (2%)
Pleura	(3)			
Inflammation, chronic	3 (100%)			
Trachea	(50)	(50)	(49)	(50)
Foreign body				1 (2%)
Inflammation, chronic		1 (2%)		
Inflammation, suppurative				1 (2%)
Special Senses System				
Eye	(3)		(2)	(3)
Lens, cataract	3 (100%)			3 (100%)

TABLE B5
Summary of the Incidence of Nonneoplastic Lesions in Female Rats in the 2-Year Inhalation Study of Vanadium Pentoxide

	Chamber Control	0.5 mg/m ³	1 mg/m ³	2 mg/m ³
Urinary System				
Kidney	(50)	(50)	(49)	(50)
Accumulation, hyaline droplet		1 (2%)		
Nephropathy, chronic	24 (48%)	21 (42%)	20 (41%)	32 (64%)
Thrombosis		1 (2%)		
Cortex, renal tubule, necrosis	1 (2%)		1 (2%)	
Papilla, mineralization			1 (2%)	2 (4%)
Pelvis, dilatation	1 (2%)			
Renal tubule, mineralization			1 (2%)	
Renal tubule, vacuolization cytoplasmic				1 (2%)
Urinary bladder	(50)	(50)	(50)	(50)
Transitional epithelium, hyperplasia		1 (2%)		

APPENDIX C
SUMMARY OF LESIONS IN MALE MICE
IN THE 2-YEAR INHALATION STUDY
OF VANADIUM PENTOXIDE

TABLE C1	Summary of the Incidence of Neoplasms in Male Mice in the 2-Year Inhalation Study of Vanadium Pentoxide	186
TABLE C2	Individual Animal Tumor Pathology of Male Mice in the 2-Year Inhalation Study of Vanadium Pentoxide	190
TABLE C3	Statistical Analysis of Primary Neoplasms in Male Mice in the 2-Year Inhalation Study of Vanadium Pentoxide	214
TABLE C4a	Historical Incidence of Alveolar/bronchiolar Neoplasms in Control Male B6C3F₁ Mice ..	216
TABLE C4b	Historical Incidence of Harderian Gland Neoplasms in Control Male B6C3F₁ Mice	217
TABLE C4c	Historical Incidence of Hepatocellular Neoplasms in Control Male B6C3F₁ Mice	218
TABLE C5	Summary of the Incidence of Nonneoplastic Lesions in Male Mice in the 2-Year Inhalation Study of Vanadium Pentoxide	219

TABLE C1
Summary of the Incidence of Neoplasms in Male Mice in the 2-Year Inhalation Study of Vanadium Pentoxide^a

	Chamber Control	1 mg/m ³	2 mg/m ³	4 mg/m ³
Disposition Summary				
Animals initially in study	50	50	50	50
Moribund	7	11	13	20
Natural deaths	4	6	1	3
Survivors				
Terminal sacrifice	39	33	36	27
Animals examined microscopically	50	50	50	50
Alimentary System				
Intestine small, duodenum	(48)	(47)	(49)	(45)
Carcinoma		1 (2%)		
Intestine small, ileum	(46)	(49)	(50)	(48)
Carcinoma	1 (2%)			
Liver	(50)	(50)	(50)	(50)
Alveolar/bronchiolar carcinoma, metastatic, lung		1 (2%)		
Hemangiosarcoma	1 (2%)			1 (2%)
Hepatocellular carcinoma	10 (20%)	13 (26%)	11 (22%)	9 (18%)
Hepatocellular carcinoma, multiple	4 (8%)	5 (10%)	3 (6%)	3 (6%)
Hepatocellular adenoma	10 (20%)	10 (20%)	8 (16%)	6 (12%)
Hepatocellular adenoma, multiple	5 (10%)	7 (14%)	2 (4%)	1 (2%)
Hepatocholangiocarcinoma			1 (2%)	
Mesentery	(9)	(7)	(8)	(1)
Alveolar/bronchiolar carcinoma, metastatic, lung		2 (29%)		
Hemangioma		1 (14%)		
Fat, alveolar/bronchiolar carcinoma, metastatic, lung			1 (13%)	
Fat, hepatocholangiocarcinoma, metastatic, liver			1 (13%)	
Pancreas	(50)	(50)	(50)	(50)
Hepatocholangiocarcinoma, metastatic, liver			1 (2%)	
Stomach, forestomach	(50)	(50)	(50)	(50)
Squamous cell papilloma	2 (4%)	1 (2%)		
Stomach, glandular	(50)	(49)	(50)	(50)
Hepatocholangiocarcinoma, metastatic, liver			1 (2%)	
Tongue	(1)			
Squamous cell papilloma	1 (100%)			
Cardiovascular System				
Heart	(50)	(50)	(50)	(50)
Alveolar/bronchiolar carcinoma, metastatic, lung		2 (4%)	1 (2%)	2 (4%)
Hepatocellular carcinoma, metastatic, liver			1 (2%)	
Pericardium, alveolar/bronchiolar carcinoma, metastatic, lung			1 (2%)	
Pericardium, hepatocellular carcinoma, metastatic, liver			1 (2%)	
Endocrine System				
Adrenal cortex	(50)	(49)	(50)	(50)
Adenoma	1 (2%)			
Adrenal medulla	(50)	(49)	(49)	(50)
Pheochromocytoma benign			1 (2%)	1 (2%)
Islets, pancreatic	(50)	(50)	(50)	(50)
Adenoma	1 (2%)			

TABLE C1
Summary of the Incidence of Neoplasms in Male Mice in the 2-Year Inhalation Study of Vanadium Pentoxide

	Chamber Control	1 mg/m ³	2 mg/m ³	4 mg/m ³
Endocrine System (continued)				
Pituitary gland	(50)	(48)	(49)	(49)
Pars distalis, adenoma	1 (2%)			
Pars distalis, carcinoma	1 (2%)			
Pars intermedia, adenoma			1 (2%)	
Thyroid gland	(48)	(50)	(50)	(50)
Carcinoma, metastatic, parathyroid gland				1 (2%)
C-cell, carcinoma				1 (2%)
Follicular cell, adenoma				2 (4%)
General Body System				
None				
Genital System				
Epididymis	(50)	(50)	(50)	(50)
Alveolar/bronchiolar carcinoma, metastatic, lung			1 (2%)	
Hepatocolangiocarcinoma, metastatic, liver			1 (2%)	
Prostate	(50)	(49)	(49)	(49)
Seminal vesicle	(50)	(50)	(50)	(50)
Adenoma	1 (2%)			
Testes	(50)	(50)	(50)	(50)
Interstitial cell, adenoma		1 (2%)		
Hematopoietic System				
Bone marrow	(50)	(50)	(50)	(50)
Histiocytic sarcoma		1 (2%)		
Lymph node		(1)		(1)
Lumbar, histiocytic sarcoma		1 (100%)		
Lymph node, bronchial	(40)	(38)	(36)	(40)
Alveolar/bronchiolar carcinoma, metastatic, lung		1 (3%)	1 (3%)	2 (5%)
Hepatocellular carcinoma, metastatic, liver			1 (3%)	
Hepatocolangiocarcinoma, metastatic, liver			1 (3%)	
Histiocytic sarcoma		1 (3%)		
Lymph node, mandibular	(34)	(43)	(27)	(35)
Histiocytic sarcoma		1 (2%)		
Lymph node, mesenteric	(46)	(47)	(48)	(44)
Carcinoma, metastatic, tissue NOS			1 (2%)	
Hemangioma			1 (2%)	
Hepatocellular carcinoma, metastatic, liver			1 (2%)	
Lymph node, mediastinal	(38)	(36)	(43)	(37)
Alveolar/bronchiolar carcinoma, metastatic, lung		1 (3%)	2 (5%)	2 (5%)
Hepatocellular carcinoma, metastatic, liver			1 (2%)	
Histiocytic sarcoma		1 (3%)		
Spleen	(50)	(50)	(50)	(50)
Hemangiosarcoma				3 (6%)
Histiocytic sarcoma		1 (2%)		
Thymus	(35)	(40)	(36)	(35)
Hemangiosarcoma		1 (3%)		

TABLE C1
Summary of the Incidence of Neoplasms in Male Mice in the 2-Year Inhalation Study of Vanadium Pentoxide

	Chamber Control	1 mg/m ³	2 mg/m ³	4 mg/m ³
Integumentary System				
Skin	(50)	(50)	(50)	(50)
Hemangiosarcoma			1 (2%)	1 (2%)
Melanoma malignant		1 (2%)		
Musculoskeletal System				
Bone	(50)	(50)	(50)	(50)
Alveolar/bronchiolar carcinoma, metastatic, lung				1 (2%)
Skeletal muscle		(3)	(2)	(3)
Alveolar/bronchiolar carcinoma, metastatic, lung		3 (100%)	1 (50%)	3 (100%)
Hepatocolangiocarcinoma, metastatic, liver			1 (50%)	
Nervous System				
Brain	(50)	(49)	(50)	(50)
Carcinoma, metastatic, pituitary gland	1 (2%)			
Respiratory System				
Lung	(50)	(50)	(50)	(50)
Alveolar/bronchiolar adenoma	12 (24%)	15 (30%)	15 (30%)	10 (20%)
Alveolar/bronchiolar adenoma, multiple	1 (2%)	1 (2%)	11 (22%)	5 (10%)
Alveolar/bronchiolar carcinoma	11 (22%)	19 (38%)	14 (28%)	22 (44%)
Alveolar/bronchiolar carcinoma, multiple	1 (2%)	10 (20%)	16 (32%)	13 (26%)
Carcinoma, metastatic, harderian gland			1 (2%)	1 (2%)
Hepatocellular carcinoma, metastatic, liver		7 (14%)	4 (8%)	4 (8%)
Hepatocolangiocarcinoma, metastatic, liver			1 (2%)	
Mediastinum, alveolar/bronchiolar carcinoma, metastatic, lung		3 (6%)	2 (4%)	5 (10%)
Mediastinum, hepatocellular carcinoma, metastatic, liver			1 (2%)	
Special Senses System				
Ear		(1)		(1)
Neural crest tumor		1 (100%)		
Harderian gland	(8)	(5)	(5)	(2)
Adenoma	6 (75%)	4 (80%)	4 (80%)	1 (50%)
Carcinoma			1 (20%)	1 (50%)
Bilateral, adenoma	2 (25%)	1 (20%)		
Urinary System				
Kidney	(50)	(50)	(50)	(50)
Adenoma		1 (2%)	1 (2%)	
Alveolar/bronchiolar carcinoma, metastatic, lung		3 (6%)	2 (4%)	1 (2%)
Hepatocellular carcinoma, metastatic, liver			1 (2%)	
Hepatocolangiocarcinoma, metastatic, liver			1 (2%)	
Histiocytic sarcoma		1 (2%)		
Urinary bladder	(50)	(50)	(50)	(50)
Papilloma	1 (2%)			

TABLE C1
Summary of the Incidence of Neoplasms in Male Mice in the 2-Year Inhalation Study of Vanadium Pentoxide

	Chamber Control	1 mg/m ³	2 mg/m ³	4 mg/m ³
Systemic Lesions				
Multiple organs ^b	(50)	(50)	(50)	(50)
Histiocytic sarcoma		1 (2%)		
Lymphoma malignant	2 (4%)	2 (4%)	1 (2%)	1 (2%)
Neoplasm Summary				
Total animals with primary neoplasms ^c	42	49	47	47
Total primary neoplasms	75	96	92	81
Total animals with benign neoplasms	31	31	36	21
Total benign neoplasms	44	42	44	26
Total animals with malignant neoplasms	27	40	38	41
Total malignant neoplasms	31	53	48	55
Total animals with metastatic neoplasms	1	11	9	11
Total metastatic neoplasms	1	23	33	22
Total animals with uncertain neoplasms- benign or malignant		1		
Total uncertain neoplasms		1		

^a Number of animals examined microscopically at the site and the number of animals with neoplasm

^b Number of animals with any tissue examined microscopically

^c Primary neoplasms: all neoplasms except metastatic neoplasms

**TABLE C2
Individual Animal Tumor Pathology of Male Mice in the 2-Year Inhalation Study of Vanadium Pentoxide:
Chamber Control**

Number of Days on Study	4	5	6	6	6	6	6	6	7	7	7	7	7	7	7	7	7	7	7	7	7	7	7	7	7	
	9	2	0	2	2	6	9	9	0	1	2	2	2	2	2	2	2	2	2	2	2	2	2	2	2	
	9	3	3	0	0	7	2	8	1	0	4	9	9	9	9	9	9	9	9	9	9	9	9	9	9	
Carcass ID Number	0	0	0	0	0	0	0	0	0	0	0	0	0	0	0	0	0	0	0	0	0	0	0	0	0	
	3	0	4	0	1	3	3	4	1	4	0	0	0	1	1	2	2	2	2	2	2	2	3	3	3	4
	9	4	8	2	0	8	0	7	7	2	9	5	8	1	9	1	3	4	6	8	9	1	5	7	1	
Alimentary System																										
Esophagus	+	+	+	+	+	+	+	+	+	+	+	+	+	+	+	+	+	+	+	+	+	+	+	+	+	
Gallbladder	+	M	A	+	M	+	+	M	+	+	M	+	I	I	+	+	+	+	+	+	+	+	+	+	+	
Intestine large, colon	+	+	+	+	+	+	+	+	+	+	A	+	+	+	+	+	+	+	+	+	+	+	+	+	+	
Intestine large, rectum	+	+	+	+	+	+	+	+	+	+	A	+	+	+	+	+	+	+	+	+	+	+	+	+	+	
Intestine large, cecum	+	A	+	A	+	+	+	+	+	+	A	+	+	+	+	+	+	+	+	+	+	+	+	+	+	
Intestine small, duodenum	+	+	A	+	+	+	+	+	+	+	A	+	+	+	+	+	+	+	+	+	+	+	+	+	+	
Intestine small, jejunum	+	A	A	A	+	+	+	+	+	+	A	+	+	+	+	+	+	+	+	+	+	+	+	+	+	
Intestine small, ileum	+	A	A	A	+	+	+	+	+	+	A	+	+	+	+	+	+	+	+	+	+	+	+	+	+	
Carcinoma																										
Liver	+	+	+	+	+	+	+	+	+	+	+	+	+	+	+	+	+	+	+	+	+	+	+	+	+	
Hemangiosarcoma																										
Hepatocellular carcinoma			X		X	X	X	X		X	X		X													
Hepatocellular carcinoma, multiple				X					X																	
Hepatocellular adenoma								X								X			X				X			
Hepatocellular adenoma, multiple																		X								
Mesentery															+	+					+	+			+	
Pancreas	+	+	+	+	+	+	+	+	+	+	+	+	+	+	+	+	+	+	+	+	+	+	+	+	+	
Salivary glands	+	+	+	+	+	+	+	+	+	+	+	+	+	+	+	+	+	+	+	+	+	+	+	+	+	
Stomach, forestomach	+	+	+	+	+	+	+	+	+	+	+	+	+	+	+	+	+	+	+	+	+	+	+	+	+	
Squamous cell papilloma																								X	X	
Stomach, glandular	+	+	+	+	+	+	+	+	+	+	+	+	+	+	+	+	+	+	+	+	+	+	+	+	+	
Tongue	+																									
Squamous cell papilloma	X																									
Tooth																										
Cardiovascular System																										
Heart	+	+	+	+	+	+	+	+	+	+	+	+	+	+	+	+	+	+	+	+	+	+	+	+	+	
Endocrine System																										
Adrenal cortex	+	+	+	+	+	+	+	+	+	+	+	+	+	+	+	+	+	+	+	+	+	+	+	+	+	
Adenoma																										
Adrenal medulla	+	+	+	+	+	+	+	+	+	+	+	+	+	+	+	+	+	+	+	+	+	+	+	+	+	
Islets, pancreatic	+	+	+	+	+	+	+	+	+	+	+	+	+	+	+	+	+	+	+	+	+	+	+	+	+	
Adenoma											X															
Parathyroid gland	+	M	M	+	+	M	M	+	+	+	+	+	+	+	+	+	+	+	+	+	M	+	+	+	+	
Pituitary gland	+	+	+	+	+	+	+	+	+	+	+	+	+	+	+	+	+	+	+	+	+	+	+	+	+	
Pars distalis, adenoma																										
Pars distalis, carcinoma																						X				
Thyroid gland	+	+	+	+	+	+	+	+	+	+	+	+	+	M	+	+	+	+	+	+	+	+	+	+	+	
General Body System																										
None																										

+: Tissue examined microscopically
A: Autolysis precludes examination

M: Missing tissue
I: Insufficient tissue

X: Lesion present
Blank: Not examined

**TABLE C2
Individual Animal Tumor Pathology of Male Mice in the 2-Year Inhalation Study of Vanadium Pentoxide:
Chamber Control**

Number of Days on Study	7	7	7	7	7	7	7	7	7	7	7	7	7	7	7	7	7	7	7	7	7	7	7	7	7	7	7	7		
	2	3	3	3	3	3	3	3	3	3	3	3	3	3	3	3	3	3	3	3	3	3	3	3	3	3	3	3	3	
	9	0	0	0	0	0	0	0	0	0	0	0	0	0	0	0	0	0	0	1	1	1	1	1	1	1	1	1		
Carcass ID Number	0	0	0	0	0	0	0	0	0	0	0	0	0	0	0	0	0	0	0	0	0	0	0	0	0	0	0	0	Total Tissues/ Tumors	
	4	0	0	0	0	1	1	2	2	3	3	4	4	4	4	5	1	1	1	1	2	2	3	3	4					
	3	1	3	6	7	3	5	0	7	2	3	0	4	5	9	0	2	4	6	8	2	5	4	6	6					
Genital System																														
Epididymis	+	+	+	+	+	+	+	+	+	+	+	+	+	+	+	+	+	+	+	+	+	+	+	+	+	+	+	+	50	
Preputial gland	+	+	+	+	+	+	+	+	+	+	+	+	+	+	+	+	+	+	+	+	+	+	+	+	+	+	+	+	49	
Prostate	+	+	+	+	+	+	+	+	+	+	+	+	+	+	+	+	+	+	+	+	+	+	+	+	+	+	+	+	50	
Seminal vesicle	+	+	+	+	+	+	+	+	+	+	+	+	+	+	+	+	+	+	+	+	+	+	+	+	+	+	+	+	50	
Adenoma																													1	
															X															
Testes	+	+	+	+	+	+	+	+	+	+	+	+	+	+	+	+	+	+	+	+	+	+	+	+	+	+	+	+	50	
Hematopoietic System																														
Bone marrow	+	+	+	+	+	+	+	+	+	+	+	+	+	+	+	+	+	+	+	+	+	+	+	+	+	+	+	+	50	
Lymph node, bronchial	+	M	+	+	+	+	+	+	M	+	+	+	+	+	+	+	+	+	+	+	+	+	+	+	+	+	M	+	40	
Lymph node, mandibular	M	+	M	+	+	+	+	+	+	+	+	+	+	+	+	M	M	+	+	M	M	+	+	+	+	M	+	+	34	
Lymph node, mesenteric	+	+	+	+	+	+	+	+	+	+	+	+	+	+	+	+	+	+	+	+	+	+	+	+	+	M	+	M	+	46
Lymph node, mediastinal	+	+	+	+	M	+	+	+	+	+	+	+	M	+	+	+	+	+	+	+	+	+	+	+	+	+	+	+	38	
Spleen	+	+	+	+	+	+	+	+	+	+	+	+	+	+	+	+	+	+	+	+	+	+	+	+	+	+	+	+	50	
Thymus	+	+	M	I	+	+	+	+	+	+	+	+	+	+	+	+	M	+	M	M	+	+	+	+	+	+	+	+	35	
Integumentary System																														
Mammary gland	M	M	M	M	M	M	M	M	M	M	M	M	M	M	M	M	M	M	M	M	M	M	M	M	M	M	M	M		
Skin	+	+	+	+	+	+	+	+	+	+	+	+	+	+	+	+	+	+	+	+	+	+	+	+	+	+	+	+	50	
Musculoskeletal System																														
Bone	+	+	+	+	+	+	+	+	+	+	+	+	+	+	+	+	+	+	+	+	+	+	+	+	+	+	+	+	50	
Nervous System																														
Brain	+	+	+	+	+	+	+	+	+	+	+	+	+	+	+	+	+	+	+	+	+	+	+	+	+	+	+	+	50	
Carcinoma, metastatic, pituitary gland																													1	
Respiratory System																														
Larynx	+	+	+	+	+	+	+	+	+	+	+	+	+	+	+	+	+	+	+	+	+	+	+	+	+	+	+	+	49	
Lung	+	+	+	+	+	+	+	+	+	+	+	+	+	+	+	+	+	+	+	+	+	+	+	+	+	+	+	+	50	
Alveolar/bronchiolar adenoma				X	X				X			X									X								12	
Alveolar/bronchiolar adenoma, multiple																													1	
Alveolar/bronchiolar carcinoma					X	X										X	X			X			X	X					11	
Alveolar/bronchiolar carcinoma, multiple																													1	
Nose	+	+	+	+	+	+	+	+	+	+	+	+	+	+	+	+	+	+	+	+	+	+	+	+	+	+	+	+	50	
Trachea	+	+	+	+	+	+	+	+	+	+	+	+	+	+	+	+	+	+	+	+	+	+	+	+	+	+	+	+	49	
Special Senses System																														
Harderian gland													+			+	+					+	+						8	
Adenoma												X				X	X					X							6	
Bilateral, adenoma																							X						2	

TABLE C2
Individual Animal Tumor Pathology of Male Mice in the 2-Year Inhalation Study of Vanadium Pentoxide:
Chamber Control

Number of Days on Study	7 7	
	2 3	
	9 0 0 0 0 0 0 0 0 0 0 0 0 0 0 0 0 1 1 1 1 1 1 1	
Carcass ID Number	0 0	Total
	4 0 0 0 0 1 1 2 2 3 3 4 4 4 4 5 1 1 1 1 2 2 3 3 4	Tissues/
	3 1 3 6 7 3 5 0 7 2 3 0 4 5 9 0 2 4 6 8 2 5 4 6 6	Tumors
Urinary System		
Kidney	+ +	50
Urinary bladder	+ +	50
Papilloma		1
		X
Systemic Lesions		
Multiple organs	+ +	50
Lymphoma malignant		2
		X

TABLE C2
Individual Animal Tumor Pathology of Male Mice in the 2-Year Inhalation Study of Vanadium Pentoxide: 1 mg/m3

Table with columns for Number of Days on Study, Carcass ID Number, and various organ systems (Alimentary, Cardiovascular, Endocrine, General Body, Genital) with tumor findings (+, X, M) and counts. Includes a 'Total Tissues/Tumors' column on the right.

TABLE C2
Individual Animal Tumor Pathology of Male Mice in the 2-Year Inhalation Study of Vanadium Pentoxide: 1 mg/m³

Table with columns for study parameters (Number of Days on Study, Carcass ID Number) and rows for various organ systems (Hematopoietic System, Integumentary System, Musculoskeletal System, Nervous System, Respiratory System) listing specific findings like sarcomas, carcinomas, and adenomas.

TABLE C2
Individual Animal Tumor Pathology of Male Mice in the 2-Year Inhalation Study of Vanadium Pentoxide: 1 mg/m³

Number of Days on Study	7 7	
	2 2 2 2 3 3 3 3 3 3 3 3 3 3 3 3 3 3 3 3 3 3 3	
	9 9 9 9 0 0 0 0 0 0 0 0 0 0 0 0 0 0 1 1 1 1 1	
Carcass ID Number	2 2	Total Tissues/Tumors
	4 4 4 4 0 0 0 1 1 2 2 3 3 3 4 4 4 1 1 1 2 3 3 4 5	
	0 2 3 8 2 8 9 1 4 0 2 5 6 7 1 6 9 2 5 7 1 8 9 4 0	
Special Senses System		
Ear		1
Neural crest tumor		1
Harderian gland		5
Adenoma		4
Bilateral, adenoma		1
Urinary System		
Kidney		50
Adenoma		1
Alveolar/bronchiolar carcinoma, metastatic, lung		3
Histiocytic sarcoma		1
Urinary bladder		50
Systemic Lesions		
Multiple organs		50
Histiocytic sarcoma		1
Lymphoma malignant		2

TABLE C2
Individual Animal Tumor Pathology of Male Mice in the 2-Year Inhalation Study of Vanadium Pentoxide: 2 mg/m³

Number of Days on Study	7	7	7	7	7	7	7	7	7	7	7	7	7	7	7	7	7	7	7	7	7	7
	2	2	2	2	2	3	3	3	3	3	3	3	3	3	3	3	3	3	3	3	3	3
	9	9	9	9	9	0	0	0	0	0	0	0	0	0	0	0	1	1	1	1	1	1
Carcass ID Number	4	4	4	4	4	4	4	4	4	4	4	4	4	4	4	4	4	4	4	4	4	4
	4	4	4	4	5	0	1	2	2	2	2	2	3	3	4	4	4	0	1	1	2	2
	5	6	8	9	0	3	9	1	2	4	7	9	3	8	0	3	4	8	2	7	5	6
Alimentary System																						
Esophagus	+	+	+	+	+	+	+	+	+	+	+	+	+	+	+	+	+	+	+	+	+	+
Gallbladder	+	+	+	+	+	+	+	+	+	+	+	+	+	+	+	+	+	+	+	+	M	+
Intestine large, colon	+	M	+	+	+	+	+	+	+	+	+	+	+	+	+	+	+	+	+	+	+	+
Intestine large, rectum	+	+	+	+	+	+	+	+	+	+	+	+	+	+	+	+	+	+	+	+	+	+
Intestine large, cecum	+	+	+	+	+	+	+	+	+	+	+	+	+	+	+	+	+	+	+	+	+	+
Intestine small, duodenum	+	+	+	+	+	+	+	+	+	+	+	+	+	+	+	+	+	+	+	+	+	+
Intestine small, jejunum	+	+	+	+	+	+	+	+	+	+	+	+	+	+	+	+	+	+	+	+	+	+
Intestine small, ileum	+	+	+	+	+	+	+	+	+	+	+	+	+	+	+	+	+	+	+	+	+	+
Liver	+	+	+	+	+	+	+	+	+	+	+	+	+	+	+	+	+	+	+	+	+	+
Hepatocellular carcinoma	X						X							X	X				X		X	
Hepatocellular carcinoma, multiple																						
Hepatocellular adenoma																	X		X	X		X
Hepatocellular adenoma, multiple				X																	X	
Hepatocholangiocarcinoma																						
Mesentery	+			+						+	+										+	
Fat, alveolar/bronchiolar carcinoma, metastatic, lung																						
Fat, hepatocholangiocarcinoma, metastatic, liver																						
Pancreas	+	+	+	+	+	+	+	+	+	+	+	+	+	+	+	+	+	+	+	+	+	+
Hepatocholangiocarcinoma, metastatic, liver																						
Salivary glands	+	+	+	+	+	+	+	+	+	+	+	+	+	+	+	+	+	+	+	+	+	+
Stomach, forestomach	+	+	+	+	+	+	+	+	+	+	+	+	+	+	+	+	+	+	+	+	+	+
Stomach, glandular	+	+	+	+	+	+	+	+	+	+	+	+	+	+	+	+	+	+	+	+	+	+
Hepatocholangiocarcinoma, metastatic, liver																						
Tooth								+				+										
Cardiovascular System																						
Heart	+	+	+	+	+	+	+	+	+	+	+	+	+	+	+	+	+	+	+	+	+	+
Alveolar/bronchiolar carcinoma, metastatic, lung																						
Hepatocellular carcinoma, metastatic, liver																						
Pericardium, alveolar/bronchiolar carcinoma, metastatic, lung																						
Pericardium, hepatocellular carcinoma, metastatic, liver																						
Endocrine System																						
Adrenal cortex	+	+	+	+	+	+	+	+	+	+	+	+	+	+	+	+	+	+	+	+	+	+
Adrenal medulla	+	+	+	+	+	+	+	+	+	+	+	+	+	+	+	+	+	+	+	+	+	+
Pheochromocytoma benign																						
Islets, pancreatic	+	+	+	+	+	+	+	+	+	+	+	+	+	+	+	+	+	+	+	+	+	+
Parathyroid gland	+	+	+	+	+	+	M	+	+	+	+	+	+	+	+	+	+	+	+	+	+	+
Pituitary gland	+	+	+	+	+	+	+	+	+	+	+	+	+	+	+	+	+	+	+	+	+	+
Pars intermedia, adenoma							X															
Thyroid gland	+	+	+	+	+	+	+	+	+	+	+	+	+	+	+	+	+	+	+	+	+	+
General Body System																						
None																						

Total
Tissues/
Tumors

50
46
49
50
50
49
49
50
50
11
3
8
2
1
8
1
1
50
1
50
50
50
1
2
50
1
1
1
1
50
49
1
44
49
1
50

TABLE C2
Individual Animal Tumor Pathology of Male Mice in the 2-Year Inhalation Study of Vanadium Pentoxide: 2 mg/m³

Number of Days on Study	7 7	2 2 2 2 2 3 3 3 3 3 3 3 3 3 3 3 3 3 3 3 3 3 3	9 9 9 9 9 0 0 0 0 0 0 0 0 0 0 0 0 0 1 1 1 1 1	
Carcass ID Number	4 4	4 4 4 4 5 0 1 2 2 2 2 2 3 3 4 4 4 0 1 1 2 2 3 4 4	5 6 8 9 0 3 9 1 2 4 7 9 3 8 0 3 4 8 2 7 5 6 1 1 7	Total Tissues/ Tumors
Genital System				
Epididymis	+ +			50
Alveolar/bronchiolar carcinoma, metastatic, lung				1
Hepatocholangiocarcinoma, metastatic, liver				1
Preputial gland	+ +			50
Prostate	+ + + + + + + + + + + + + + + M + + + + + + + + + +			49
Seminal vesicle	+ +			50
Testes	+ +			50
Hematopoietic System				
Bone marrow	+ +			50
Lymph node, bronchial	+ + + M M + + + + M M + + M + + + + + + + + + M			36
Alveolar/bronchiolar carcinoma, metastatic, lung				1
Hepatocellular carcinoma, metastatic, liver				1
Hepatocholangiocarcinoma, metastatic, liver				1
Lymph node, mandibular	M + M + + + + + M M M M + M M + M + + M + + + M +			27
Lymph node, mesenteric	+ + + + + + + + + + + + + + + + M + + + + + + + + +			48
Carcinoma, metastatic, tissue NOS				1
Hemangioma				1
Hepatocellular carcinoma, metastatic, liver				1
Lymph node, mediastinal	+ + + + M + + + + + + + + + + + M + + + M + + + +			43
Alveolar/bronchiolar carcinoma, metastatic, lung				2
Hepatocellular carcinoma, metastatic, liver				1
Spleen	+ +			50
Thymus	M + M M + M + + + + + + + M + + + + + + + M + + +			36
Integumentary System				
Mammary gland	M M			50
Skin	+ +			50
Hemangiosarcoma				1
Musculoskeletal System				
Bone	+ +			50
Skeletal muscle				2
Alveolar/bronchiolar carcinoma, metastatic, lung				1
Hepatocholangiocarcinoma, metastatic, liver				1
Nervous System				
Brain	+ +			50
Spinal cord				1

TABLE C2
Individual Animal Tumor Pathology of Male Mice in the 2-Year Inhalation Study of Vanadium Pentoxide: 2 mg/m³

Number of Days on Study	4	5	6	6	6	6	6	6	6	6	7	7	7	7	7	7	7	7	7	7	7	7
	2	3	0	1	1	3	3	5	9	9	9	0	1	1	2	2	2	2	2	2	2	2
	2	4	6	1	7	9	9	3	5	5	5	9	8	8	9	9	9	9	9	9	9	9
Carcass ID Number	4	4	4	4	4	4	4	4	4	4	4	4	4	4	4	4	4	4	4	4	4	4
	1	1	4	3	3	2	2	1	0	1	2	0	0	0	0	0	0	1	1	1	3	3
	6	5	2	0	5	0	8	0	6	4	3	2	1	4	5	7	9	1	3	8	2	4
Respiratory System																						
Larynx	+	+	+	A	+	+	+	+	+	+	+	+	+	+	+	+	+	+	+	+	+	+
Lung	+	+	+	+	+	+	+	+	+	+	+	+	+	+	+	+	+	+	+	+	+	+
Alveolar/bronchiolar adenoma									X								X	X		X		
Alveolar/bronchiolar adenoma, multiple			X												X					X		X
Alveolar/bronchiolar carcinoma	X	X						X			X							X		X		
Alveolar/bronchiolar carcinoma, multiple					X		X			X	X	X				X	X			X	X	X
Carcinoma, metastatic, harderian gland																						
Hepatocellular carcinoma, metastatic, liver												X	X	X								
Hepatocholangiocarcinoma, metastatic, liver								X														
Mediastinum, alveolar/bronchiolar carcinoma, metastatic, lung			X						X													
Mediastinum, hepatocellular carcinoma, metastatic, liver														X								
Nose	+	+	+	+	+	+	+	+	+	+	+	+	+	+	+	+	+	+	+	+	+	+
Pleura					+																	
Trachea	+	+	+	+	+	+	+	+	+	+	+	+	+	+	+	+	+	I	+	+	+	+
Special Senses System																						
Eye																	+					
Harderian gland					+		+		+												+	
Adenoma				X			X		X												X	
Carcinoma																						
Urinary System																						
Kidney	+	+	+	+	+	+	+	+	+	+	+	+	+	+	+	+	+	+	+	+	+	+
Adenoma																						
Alveolar/bronchiolar carcinoma, metastatic, lung			X						X													
Hepatocellular carcinoma, metastatic, liver															X							
Hepatocholangiocarcinoma, metastatic, liver								X														
Urinary bladder	+	+	+	+	+	+	+	+	+	+	+	+	+	+	+	+	+	+	+	+	+	+
Systemic Lesions																						
Multiple organs	+	+	+	+	+	+	+	+	+	+	+	+	+	+	+	+	+	+	+	+	+	+
Lymphoma malignant															X							

TABLE C2
Individual Animal Tumor Pathology of Male Mice in the 2-Year Inhalation Study of Vanadium Pentoxide: 4 mg/m³

Number of Days on Study	7 7																											
	2 2 2 2 2 2 2 2 2 2 2 3 3 3 3 3 3 3 3 3 3																											
	9 9 9 9 9 9 9 9 9 9 9 9 0 0 0 0 0 0 0 0 1 1																											
Carcass ID Number																					Total Tissues/ Tumors							
	6 6																											
	1 1 1 2 2 3 3 4 4 4 4 0 0 1 2 3 3 3 3 4 4 5 0 0																											
	1 3 4 4 5 5 8 1 3 5 9 3 4 9 8 2 3 4 6 7 2 7 0 1 2																											
Hematopoietic System																												
Bone marrow	+																				50							
Lymph node																					1							
Lymph node, bronchial	M	+	+	+	+	+	+	+	+	+	+	+	+	+	+	+	+	+	M	+	+	M	M	+	+	+	+	40
Alveolar/bronchiolar carcinoma, metastatic, lung																												2
Lymph node, mandibular	+	+	+	+	+	M	+	M	M	M	+	+	M	+	+	+	+	M	M	+	M	M	+	+	+	+	35	
Lymph node, mesenteric	+	+	+	+	+	+	M	+	+	+	+	+	+	+	+	+	+	+	+	+	+	+	+	+	+	+	44	
Lymph node, mediastinal	+	+	M	+	M	+	M	+	+	+	+	M	+	+	+	M	+	M	+	M	+	+	+	+	+	+	37	
Alveolar/bronchiolar carcinoma, metastatic, lung																											2	
Spleen	+																				50							
Hemangiosarcoma														X													3	
Thymus	+	+	+	+	+	M	M	+	+	+	+	+	M	M	+	+	M	+	+	M	M	+	M	+	+	+	35	
Integumentary System																												
Mammary gland	M	M	M	M	M	M	M	M	M	M	+	M	M	M	M	M	M	M	M	M	M	M	M	M	M	M	1	
Skin	+																				50							
Hemangiosarcoma														X													1	
Musculoskeletal System																												
Bone	+																				50							
Alveolar/bronchiolar carcinoma, metastatic, lung																											1	
Skeletal muscle																					3							
Alveolar/bronchiolar carcinoma, metastatic, lung																											3	
Nervous System																												
Brain	+																				50							
Respiratory System																												
Larynx	+																				50							
Lung	+																				50							
Alveolar/bronchiolar adenoma		X							X				X											X			10	
Alveolar/bronchiolar adenoma, multiple					X					X				X												X	5	
Alveolar/bronchiolar carcinoma			X			X		X		X		X		X		X								X			22	
Alveolar/bronchiolar carcinoma, multiple				X		X				X					X								X		X		13	
Carcinoma, metastatic, harderian gland														X													1	
Hepatocellular carcinoma, metastatic, liver																				X							4	
Mediastinum, alveolar/bronchiolar carcinoma, metastatic, lung																											5	
Nose	+																				50							
Pleura											+																2	
Trachea	+																				50							

TABLE C2
Individual Animal Tumor Pathology of Male Mice in the 2-Year Inhalation Study of Vanadium Pentoxide: 4 mg/m³

Number of Days on Study	7 7	
	2 2 2 2 2 2 2 2 2 2 2 3 3 3 3 3 3 3 3 3 3 3 3	
	9 9 9 9 9 9 9 9 9 9 9 0 0 0 0 0 0 0 0 0 0 0 1 1	
Carcass ID Number	6 6	Total Tissues/ Tumors
	1 1 1 2 2 3 3 4 4 4 4 0 0 1 2 3 3 3 3 3 4 4 5 0 0	
	1 3 4 4 5 5 8 1 3 5 9 3 4 9 8 2 3 4 6 7 2 7 0 1 2	
Special Senses System		
Ear		1
Harderian gland	+	2
Adenoma		1
Carcinoma	X	1
Urinary System		
Kidney	+ +	50
Alveolar/bronchiolar carcinoma, metastatic, lung		1
Urinary bladder	+ +	50
Systemic Lesions		
Multiple organs	+ +	50
Lymphoma malignant		1

TABLE C3
Statistical Analysis of Primary Neoplasms in Male Mice in the 2-Year Inhalation Study of Vanadium Pentoxide

	Chamber Control	1 mg/m ³	2 mg/m ³	4 mg/m ³
Harderian Gland: Adenoma				
Overall rate ^a	8/50 (16%)	5/50 (10%)	4/50 (8%)	1/50 (2%)
Adjusted rate ^b	17.1%	11.3%	8.6%	2.5%
Terminal rate ^c	7/39 (18%)	5/33 (15%)	1/36 (3%)	0/27 (0%)
First incidence (days) ^d	698	729 (T)	617	667
Poly-3 test	P=0.018N	P=0.316N	P=0.179N	P=0.028N
Harderian Gland: Adenoma or Carcinoma				
Overall rate	8/50 (16%)	5/50 (10%)	5/50 (10%)	2/50 (4%)
Adjusted rate	17.1%	11.3%	10.7%	4.9%
Terminal rate	7/39 (18%)	5/33 (15%)	2/36 (6%)	1/27 (4%)
First incidence (days)	698	729 (T)	617	667
Poly-3 test	P=0.058N	P=0.316N	P=0.279N	P=0.074N
Liver: Hepatocellular Adenoma				
Overall rate	15/50 (30%)	17/50 (34%)	10/50 (20%)	7/50 (14%)
Adjusted rate	32.0%	37.0%	21.6%	16.9%
Terminal rate	14/39 (36%)	14/33 (42%)	8/36 (22%)	4/27 (15%)
First incidence (days)	692	514	639	541
Poly-3 test	P=0.028N	P=0.384	P=0.185N	P=0.080N
Liver: Hepatocellular Carcinoma				
Overall rate	14/50 (28%)	18/50 (36%)	14/50 (28%)	12/50 (24%)
Adjusted rate	28.5%	39.4%	29.9%	27.8%
Terminal rate	5/39 (13%)	13/33 (39%)	9/36 (25%)	5/27 (19%)
First incidence (days)	523	590	611	541
Poly-3 test	P=0.391N	P=0.181	P=0.527	P=0.565N
Liver: Hepatocellular Adenoma or Carcinoma				
Overall rate	26/50 (52%)	30/50 (60%)	22/50 (44%)	17/50 (34%)
Adjusted rate	52.8%	63.2%	46.6%	39.2%
Terminal rate	17/39 (44%)	22/33 (67%)	15/36 (42%)	9/27 (33%)
First incidence (days)	523	514	611	541
Poly-3 test	P=0.045N	P=0.204	P=0.341N	P=0.131N
Lung: Alveolar/bronchiolar Adenoma				
Overall rate	13/50 (26%)	16/50 (32%)	26/50 (52%)	15/50 (30%)
Adjusted rate	27.0%	34.8%	55.9%	35.4%
Terminal rate	6/39 (15%)	11/33 (33%)	24/36 (67%)	10/27 (37%)
First incidence (days)	620	405	611	562
Poly-3 test	P=0.143	P=0.276	P=0.003	P=0.263
Lung: Alveolar/bronchiolar Carcinoma				
Overall rate	12/50 (24%)	29/50 (58%)	30/50 (60%)	35/50 (70%)
Adjusted rate	25.5%	60.3%	62.3%	72.8%
Terminal rate	11/39 (28%)	17/33 (52%)	21/36 (58%)	15/27 (56%)
First incidence (days)	667	530	534	394
Poly-3 test	P<0.001	P<0.001	P<0.001	P<0.001
Lung: Alveolar/bronchiolar Adenoma or Carcinoma				
Overall rate	22/50 (44%)	42/50 (84%)	43/50 (86%)	43/50 (86%)
Adjusted rate	45.7%	84.6%	88.1%	88.5%
Terminal rate	15/39 (39%)	26/33 (79%)	32/36 (89%)	22/27 (82%)
First incidence (days)	620	405	534	394
Poly-3 test	P<0.001	P<0.001	P<0.001	P<0.001

TABLE C3
Statistical Analysis of Primary Neoplasms in Male Mice in the 2-Year Inhalation Study of Vanadium Pentoxide

	Chamber Control	1 mg/m ³	2 mg/m ³	4 mg/m ³
Spleen: Hemangiosarcoma				
Overall rate	0/50 (0%)	0/50 (0%)	0/50 (0%)	3/50 (6%)
Adjusted rate	0.0%	0.0%	0.0%	7.4%
Terminal rate	0/39 (0%) ^e	0/33 (0%)	0/36 (0%)	2/27 (7%)
First incidence (days)	—	— ^f	—	667
Poly-3 test	P=0.010	—	—	P=0.095
All Organs: Hemangiosarcoma				
Overall rate	1/50 (2%)	1/50 (2%)	1/50 (2%)	3/50 (6%)
Adjusted rate	2.1%	2.3%	2.2%	7.4%
Terminal rate	1/39 (3%)	1/33 (3%)	1/36 (3%)	2/27 (7%)
First incidence (days)	729 (T)	729 (T)	729 (T)	667
Poly-3 test	P=0.140	P=0.747	P=0.756	P=0.256
All Organs: Hemangioma or Hemangiosarcoma				
Overall rate	1/50 (2%)	2/50 (4%)	2/50 (4%)	3/50 (6%)
Adjusted rate	2.1%	4.5%	4.4%	7.4%
Terminal rate	1/39 (3%)	2/33 (6%)	1/36 (3%)	2/27 (7%)
First incidence (days)	729 (T)	729 (T)	718	667
Poly-3 test	P=0.188	P=0.479	P=0.493	P=0.256
All Organs: Benign Neoplasms				
Overall rate	31/50 (62%)	31/50 (62%)	36/50 (72%)	21/50 (42%)
Adjusted rate	63.4%	65.6%	75.2%	48.1%
Terminal rate	22/39 (56%)	23/33 (70%)	28/36 (78%)	12/27 (44%)
First incidence (days)	499	405	611	541
Poly-3 test	P=0.090N	P=0.493	P=0.144	P=0.098N
All Organs: Malignant Neoplasms				
Overall rate	27/50 (54%)	40/50 (80%)	38/50 (76%)	41/50 (82%)
Adjusted rate	54.9%	81.1%	77.3%	83.4%
Terminal rate	18/39 (46%)	25/33 (76%)	25/36 (69%)	19/27 (70%)
First incidence (days)	523	405	534	394
Poly-3 test	P=0.004	P=0.004	P=0.015	P<0.001
All Organs: Benign or Malignant Neoplasms				
Overall rate	42/50 (84%)	49/50 (98%)	47/50 (94%)	47/50 (94%)
Adjusted rate	84.0%	98.0%	95.5%	95.6%
Terminal rate	31/39 (80%)	32/33 (97%)	34/36 (94%)	25/27 (93%)
First incidence (days)	499	405	534	394
Poly-3 test	P=0.052	P=0.016	P=0.056	P=0.055

(T) Terminal sacrifice

^a Number of neoplasm-bearing animals/number of animals examined. Denominator is number of animals examined microscopically for liver, lung, and spleen; for other tissues, denominator is number of animals necropsied.

^b Poly-3 estimated neoplasm incidence after adjustment for intercurrent mortality

^c Observed incidence at terminal kill

^d Beneath the chamber control incidence is the P value associated with the trend test. Beneath the exposed group incidence are the P values corresponding to pairwise comparisons between the chamber controls and that exposed group. The Poly-3 test accounts for the differential mortality in animals that do not reach terminal sacrifice. A negative trend or a lower incidence in an exposure group is indicated by N.

^e Not applicable; no neoplasms in animal group

^f Value of statistic cannot be computed.

TABLE C4a
Historical Incidence of Alveolar/bronchiolar Neoplasms in Control Male B6C3F₁ Mice

	Incidence in Controls		
	Adenoma	Carcinoma	Adenoma or Carcinoma
Historical Incidence in Controls Given NTP-2000 Diet^a			
Acrylonitrile (gavage)	10/50	4/50	14/50
Citral (feed)	12/100	9/100	20/100
<i>p,p'</i> -Dichlorodiphenyl sulfone (feed)	6/50	7/50	13/50
Indium phosphide (inhalation)	13/50	6/50	18/50
60-Hz Magnetic fields (whole body exposure)	26/100	8/100	30/100
Methacrylonitrile (gavage)	2/49	4/49	6/49
<i>o</i> -Nitrotoluene (feed)	9/60	5/60	14/60
<i>p</i> -Nitrotoluene (feed)	6/50	2/50	8/50
Riddelliine (gavage)	12/50	7/50	18/50
Sodium nitrite (drinking water)	10/50	4/50	13/50
Vanadium pentoxide (inhalation)	13/50	12/50	22/50
Overall Historical Incidence in Controls Given NTP-2000 Diet			
Total (%)	119/659 (18.1%)	68/659 (10.3%)	176/659 (26.7%)
Mean ± standard deviation	17.9% ± 7.4%	10.7% ± 5.3%	27.1% ± 9.3%
Range	4%-26%	4%-24%	12%-44%
Historical Incidence in Chamber Controls Given NIH-07 Diet at Battelle Pacific Northwest Laboratories^b			
Acetonitrile	6/50	4/50	10/50
1,3-Butadiene	18/50	5/50	21/50
2-Butoxyethanol	9/50	5/50	14/50
Chloroprene	8/50	6/50	13/50
Cobalt sulfate heptahydrate	9/50	4/50	11/50
Furfuryl alcohol	16/50	4/50	20/50
Gallium arsenide	13/50	3/50	15/50
Glutaraldehyde	8/48	10/48	18/48
Hexachlorocyclopentadiene	11/49	0/49	11/49
Isobutene	12/50	6/50	17/50
Isobutyraldehyde	5/50	7/50	12/50
Molybdenum trioxide	9/50	2/50	11/50
Nitromethane	11/50	2/50	13/50
Ozone	6/50	8/50	14/50
Tetrahydrofuran	18/50	6/50	21/50
Overall Historical Incidence in Chamber Controls Given NIH-07 Diet			
Total (%)	201/1,071 (18.8%)	97/1,071 (9.1%)	285/1,071 (26.6%)
Mean ± standard deviation	19.0% ± 8.4%	9.0% ± 5.2%	26.8% ± 8.3%
Range	8%-36%	0%-21%	14%-42%

^a Data as of December 20, 2000

^b Data as of December 23, 1999

TABLE C4b
Historical Incidence of Harderian Gland Neoplasms in Control Male B6C3F₁ Mice

	Incidence in Controls		
	Adenoma	Carcinoma	Adenoma or Carcinoma
Historical Incidence in Controls Given NTP-2000 Diet^a			
Acrylonitrile (gavage)	5/50	1/50	6/50
Citral (feed)	4/100	0/100	4/100
<i>p,p'</i> -Dichlorodiphenyl sulfone (feed)	5/50	0/50	5/50
Indium phosphide (inhalation)	1/50	0/50	1/50
60-Hz Magnetic fields (whole body exposure)	12/100	0/100	12/100
Methacrylonitrile (gavage)	3/49	0/49	3/49
<i>o</i> -Nitrotoluene (feed)	4/60	1/60	5/60
<i>p</i> -Nitrotoluene (feed)	3/50	0/50	3/50
Riddelliine (gavage)	4/50	2/50	6/50
Sodium nitrite (drinking water)	4/50	0/50	4/50
Vanadium pentoxide (inhalation)	8/50	0/50	8/50
Overall Historical Incidence in Controls Given NTP-2000 Diet			
Total (%)	53/659 (8.0%)	4/659 (0.6%)	57/659 (8.7%)
Mean ± standard deviation	8.1% ± 3.9%	0.7% ± 1.3%	8.8% ± 4.1%
Range	2%-16%	0%-4%	2%-16%
Historical Incidence in Chamber Controls Given NIH-07 Diet at Battelle Pacific Northwest Laboratories^b			
Acetonitrile	5/50	0/50	5/50
1,3-Butadiene	6/50	0/50	6/50
2-Butoxyethanol	3/50	0/50	3/50
Chloroprene	2/50	0/50	2/50
Cobalt sulfate heptahydrate	4/50	0/50	4/50
Furfuryl alcohol	3/50	1/50	4/50
Glutaraldehyde	3/50	1/50	4/50
Hexachlorocyclopentadiene	7/50	0/50	7/50
Isobutene	3/50	1/50	4/50
Isobutyraldehyde	1/50	2/50	3/50
Molybdenum trioxide	1/50	2/50	3/50
Ozone	1/50	0/50	1/50
Tetrahydrofuran	1/50	3/50	4/50
Overall Historical Incidence in Chamber Controls Given NIH-07 Diet			
Total (%)	48/974 (4.9%)	10/974 (1.0%)	58/974 (5.6%)
Mean ± standard deviation	4.6% ± 4.1%	1.0% ± 1.8%	5.5% ± 4.1%
Range	0%-14%	0%-6%	0%-14%

^a Data as of December 20, 2000

^b Data as of December 23, 1999

TABLE C4c
Historical Incidence of Hepatocellular Neoplasms in Control Male B6C3F₁ Mice

	Incidence in Controls		
	Adenoma	Carcinoma	Adenoma or Carcinoma
Historical Incidence in Controls Given NTP-2000 Diet^a			
Acrylonitrile (gavage)	23/50	14/50	32/50
Citral (feed)	20/100	13/100	28/100
<i>p,p'</i> -Dichlorodiphenyl sulfone (feed)	6/50	9/50	15/50
Indium phosphide (inhalation)	17/50	11/50	26/50
60-Hz Magnetic fields (whole body exposure)	30/100	19/100	46/100
Methacrylonitrile (gavage)	17/49	13/49	24/49
<i>o</i> -Nitrotoluene (feed)	18/60	12/60	27/60
<i>p</i> -Nitrotoluene (feed)	14/50	8/50	20/50
Riddelliine (gavage)	16/50	23/50	36/50
Sodium nitrite (drinking water)	19/50	9/50	24/50
Vanadium pentoxide (inhalation)	15/50	14/50	26/50
Overall Historical Incidence in Controls Given NTP-2000 Diet			
Total (%)	195/659 (29.6%)	145/659 (22.0%)	304/659 (46.1%)
Mean ± standard deviation	30.4% ± 8.9%	23.1% ± 9.0%	47.8% ± 12.9%
Range	12%-46%	13%-46%	28%-72%
Historical Incidence in Chamber Controls Given NIH-07 Diet at Battelle Pacific Northwest Laboratories^b			
Acetonitrile	13/50	7/50	19/50
1,3-Butadiene	13/50	11/50	21/50
2-Butoxyethanol	22/50	10/50	30/50
Chloroprene	22/50	24/50	43/50
Cobalt sulfate heptahydrate	22/50	23/50	38/50
Furfuryl alcohol	13/50	15/50	28/50
Gallium arsenide	16/50	13/50	26/50
Glutaraldehyde	19/49	15/49	32/49
Hexachlorocyclopentadiene	19/50	7/50	24/50
Isobutene	20/50	13/50	30/50
Isobutyraldehyde	12/49	17/49	27/49
Molybdenum trioxide	20/50	12/50	30/50
Nitromethane	17/50	16/50	29/50
Ozone	23/50	12/50	30/50
Tetrahydrofuran	24/50	14/50	35/50
Overall Historical Incidence in Chamber Controls Given NIH-07 Diet			
Total (%)	356/1,072 (33.2%)	279/1,072 (26.0%)	582/1,072 (54.3%)
Mean ± standard deviation	33.4% ± 9.3%	26.3% ± 9.6%	54.7% ± 14.0%
Range	15%-48%	11%-48%	22%-86%

^a Data as of December 20, 2000

^b Data as of December 23, 1999

TABLE C5
Summary of the Incidence of Nonneoplastic Lesions in Male Mice in the 2-Year Inhalation Study of Vanadium Pentoxide^a

	Chamber Control	1 mg/m ³	2 mg/m ³	4 mg/m ³
Disposition Summary				
Animals initially in study	50	50	50	50
Moribund	7	11	13	20
Natural deaths	4	6	1	3
Survivors				
Terminal sacrifice	39	33	36	27
Animals examined microscopically	50	50	50	50
Alimentary System				
Esophagus	(50)	(50)	(50)	(49)
Inflammation	2 (4%)			
Intestine small, jejunum	(46)	(48)	(49)	(47)
Inflammation			1 (2%)	
Intestine small, ileum	(46)	(49)	(50)	(48)
Inflammation, chronic	1 (2%)			
Liver	(50)	(50)	(50)	(50)
Angiectasis			1 (2%)	
Basophilic focus	2 (4%)			
Clear cell focus	4 (8%)	2 (4%)		
Clear cell focus, multiple		1 (2%)		
Eosinophilic focus	19 (38%)	11 (22%)	14 (28%)	17 (34%)
Eosinophilic focus, multiple	1 (2%)	5 (10%)	5 (10%)	2 (4%)
Hematopoietic cell proliferation		1 (2%)		
Infarct		1 (2%)		
Inflammation, focal, granulomatous	2 (4%)	6 (12%)	7 (14%)	3 (6%)
Mixed cell focus	1 (2%)			
Necrosis, focal	8 (16%)	3 (6%)	5 (10%)	4 (8%)
Pigmentation, hemosiderin			3 (6%)	1 (2%)
Tension lipidosis	2 (4%)	4 (8%)	2 (4%)	3 (6%)
Vacuolization cytoplasmic	1 (2%)	1 (2%)		
Centrilobular, degeneration	1 (2%)	1 (2%)	1 (2%)	
Centrilobular, necrosis		1 (2%)		
Mesentery	(9)	(7)	(8)	(1)
Artery, inflammation	1 (11%)			
Fat, inflammation	3 (33%)		3 (38%)	
Fat, necrosis	5 (56%)	3 (43%)	4 (50%)	1 (100%)
Oral mucosa		(1)		
Pharyngeal, cyst		1 (100%)		
Pancreas	(50)	(50)	(50)	(50)
Atrophy	3 (6%)	3 (6%)	5 (10%)	2 (4%)
Salivary glands	(50)	(50)	(50)	(50)
Inflammation		4 (8%)	2 (4%)	
Necrosis			1 (2%)	
Stomach, forestomach	(50)	(50)	(50)	(50)
Angiectasis				1 (2%)
Inflammation, suppurative		2 (4%)	1 (2%)	
Mineralization		1 (2%)		
Ulcer	1 (2%)	2 (4%)	2 (4%)	1 (2%)
Epithelium, hyperplasia	3 (6%)	10 (20%)	6 (12%)	4 (8%)

^a Number of animals examined microscopically at the site and the number of animals with lesion

TABLE C5
Summary of the Incidence of Nonneoplastic Lesions in Male Mice in the 2-Year Inhalation Study of Vanadium Pentoxide

	Chamber Control	1 mg/m ³	2 mg/m ³	4 mg/m ³
Alimentary System (continued)				
Stomach, glandular	(50)	(49)	(50)	(50)
Infiltration cellular		1 (2%)		
Inflammation, suppurative		1 (2%)	1 (2%)	
Mineralization			1 (2%)	
Ulcer			1 (2%)	1 (2%)
Epithelium, hyperplasia		1 (2%)		1 (2%)
Tooth	(2)	(1)	(2)	
Inflammation		1 (100%)		
Malformation	2 (100%)	1 (100%)	2 (100%)	
Cardiovascular System				
Heart	(50)	(50)	(50)	(50)
Angiectasis	1 (2%)			
Cardiomyopathy	48 (96%)	48 (96%)	48 (96%)	47 (94%)
Mineralization		1 (2%)		
Thrombosis	1 (2%)			
Artery, inflammation	1 (2%)	1 (2%)		1 (2%)
Capillary, hyperplasia	1 (2%)			
Endocrine System				
Adrenal cortex	(50)	(49)	(50)	(50)
Degeneration, cystic		1 (2%)		
Hyperplasia	9 (18%)		2 (4%)	
Hypertrophy	40 (80%)	36 (73%)	31 (62%)	31 (62%)
Adrenal medulla	(50)	(49)	(49)	(50)
Hyperplasia		2 (4%)	1 (2%)	1 (2%)
Islets, pancreatic	(50)	(50)	(50)	(50)
Hyperplasia	11 (22%)	6 (12%)	1 (2%)	2 (4%)
Pituitary gland	(50)	(48)	(49)	(49)
Pars distalis, cyst	2 (4%)	3 (6%)	3 (6%)	
Pars distalis, hyperplasia	4 (8%)	3 (6%)		1 (2%)
Thyroid gland	(48)	(50)	(50)	(50)
Follicular cell, hyperplasia	1 (2%)			
General Body System				
None				
Genital System				
Epididymis	(50)	(50)	(50)	(50)
Granuloma sperm	1 (2%)			1 (2%)
Inflammation	3 (6%)		1 (2%)	
Preputial gland	(49)	(50)	(50)	(49)
Ectasia	15 (31%)	19 (38%)	13 (26%)	20 (41%)
Inflammation	2 (4%)	5 (10%)	5 (10%)	3 (6%)
Prostate	(50)	(49)	(49)	(49)
Inflammation	4 (8%)	1 (2%)		
Inflammation, suppurative		1 (2%)		

TABLE C5
Summary of the Incidence of Nonneoplastic Lesions in Male Mice in the 2-Year Inhalation Study of Vanadium Pentoxide

	Chamber Control	1 mg/m ³	2 mg/m ³	4 mg/m ³
Genital System (continued)				
Seminal vesicle	(50)	(50)	(50)	(50)
Congestion		1 (2%)		
Inflammation, chronic		2 (4%)		
Inflammation, suppurative			1 (2%)	1 (2%)
Epithelium, degeneration	1 (2%)			
Epithelium, hyperplasia				1 (2%)
Testes	(50)	(50)	(50)	(50)
Atrophy	4 (8%)	7 (14%)	1 (2%)	5 (10%)
Interstitial cell, hyperplasia	1 (2%)			1 (2%)
Hematopoietic System				
Bone marrow	(50)	(50)	(50)	(50)
Hyperplasia	8 (16%)	5 (10%)	4 (8%)	4 (8%)
Thrombosis	1 (2%)			
Lymph node, bronchial	(40)	(38)	(36)	(40)
Hyperplasia	7 (18%)	7 (18%)	12 (33%)	13 (33%)
Lymph node, mandibular	(34)	(43)	(27)	(35)
Hyperplasia	1 (3%)		1 (4%)	1 (3%)
Infiltration cellular, plasma cell			1 (4%)	
Lymph node, mesenteric	(46)	(47)	(48)	(44)
Hematopoietic cell proliferation		1 (2%)	2 (4%)	
Hyperplasia	3 (7%)	7 (15%)	2 (4%)	2 (5%)
Lymph node, mediastinal	(38)	(36)	(43)	(37)
Hyperplasia	2 (5%)	3 (8%)	4 (9%)	6 (16%)
Spleen	(50)	(50)	(50)	(50)
Angiectasis		1 (2%)		1 (2%)
Hematopoietic cell proliferation	15 (30%)	13 (26%)	18 (36%)	10 (20%)
Hyperplasia, lymphoid	9 (18%)	12 (24%)	15 (30%)	10 (20%)
Infiltration cellular, histiocyte		1 (2%)		
Inflammation, focal, granulomatous				1 (2%)
Thymus	(35)	(40)	(36)	(35)
Epithelial cell, hyperplasia				1 (3%)
Integumentary System				
Skin	(50)	(50)	(50)	(50)
Cyst epithelial inclusion	1 (2%)			
Inflammation, focal, granulomatous	1 (2%)			
Inflammation, suppurative	1 (2%)		1 (2%)	1 (2%)
Epidermis, hyperplasia	2 (4%)			
Prepuce, inflammation, chronic active	7 (14%)	1 (2%)	1 (2%)	2 (4%)
Musculoskeletal System				
Bone	(50)	(50)	(50)	(50)
Fibrous osteodystrophy	1 (2%)	3 (6%)	2 (4%)	2 (4%)
Fracture			1 (2%)	

TABLE C5
Summary of the Incidence of Nonneoplastic Lesions in Male Mice in the 2-Year Inhalation Study of Vanadium Pentoxide

	Chamber Control	1 mg/m ³	2 mg/m ³	4 mg/m ³
Nervous System				
Brain	(50)	(49)	(50)	(50)
Meninges, infiltration cellular, mononuclear cell		1 (2%)		
Spinal cord			(1)	
Hyperplasia, lymphoid			1 (100%)	
Respiratory System				
Larynx	(49)	(50)	(49)	(50)
Inflammation, suppurative	2 (4%)		3 (6%)	
Respiratory epithelium, epiglottis, metaplasia, squamous	2 (4%)	45 (90%)	41 (85%)	41 (82%)
Squamous epithelium, hyperplasia	5 (10%)	4 (8%)	11 (23%)	5 (10%)
Lung	(50)	(50)	(50)	(50)
Hemorrhage	2 (4%)	3 (6%)	3 (6%)	1 (2%)
Inflammation, chronic	6 (12%)	42 (84%)	45 (90%)	47 (94%)
Inflammation, suppurative	1 (2%)			
Necrosis		1 (2%)		
Thrombosis		1 (2%)		
Alveolar epithelium, hyperplasia	3 (6%)	41 (82%)	49 (98%)	50 (100%)
Alveolus, infiltration cellular, histiocyte	10 (20%)	36 (72%)	45 (90%)	49 (98%)
Bronchiole, epithelium, hyperplasia		15 (30%)	37 (74%)	46 (92%)
Interstitial, fibrosis	1 (2%)	6 (12%)	9 (18%)	12 (24%)
Mediastinum, inflammation	1 (2%)	1 (2%)		
Nose	(50)	(50)	(50)	(50)
Hemorrhage			1 (2%)	
Inflammation, chronic		1 (2%)	1 (2%)	
Inflammation, suppurative	16 (32%)	11 (22%)	32 (64%)	23 (46%)
Lateral wall, hyperplasia			2 (4%)	1 (2%)
Lateral wall, metaplasia, squamous		1 (2%)	1 (2%)	1 (2%)
Olfactory epithelium, atrophy	6 (12%)	7 (14%)	9 (18%)	12 (24%)
Olfactory epithelium, degeneration, hyaline	1 (2%)	7 (14%)	23 (46%)	30 (60%)
Respiratory epithelium, degeneration, hyaline	8 (16%)	22 (44%)	38 (76%)	41 (82%)
Respiratory epithelium, metaplasia, squamous		6 (12%)	6 (12%)	2 (4%)
Respiratory epithelium, necrosis			1 (2%)	2 (4%)
Pleura		(4)	(2)	(2)
Mesothelium, hyperplasia		4 (100%)	2 (100%)	1 (50%)
Trachea	(49)	(50)	(49)	(50)
Inflammation, suppurative	1 (2%)			
Special Senses System				
Ear		(1)		(1)
Inflammation				1 (100%)
Internal ear, necrosis				1 (100%)

TABLE C5
Summary of the Incidence of Nonneoplastic Lesions in Male Mice in the 2-Year Inhalation Study of Vanadium Pentoxide

	Chamber Control	1 mg/m ³	2 mg/m ³	4 mg/m ³
Urinary System				
Kidney	(50)	(50)	(50)	(50)
Accumulation, hyaline droplet				1 (2%)
Atrophy		1 (2%)		
Cyst	5 (10%)	3 (6%)	7 (14%)	6 (12%)
Hydronephrosis		2 (4%)		
Infarct, chronic			2 (4%)	
Infiltration cellular, lipocyte		1 (2%)		
Metaplasia, osseous	2 (4%)	7 (14%)	7 (14%)	1 (2%)
Mineralization		1 (2%)		
Nephropathy	48 (96%)	50 (100%)	48 (96%)	48 (96%)
Papilla, necrosis	2 (4%)			
Renal tubule, hyperplasia	5 (10%)	7 (14%)	2 (4%)	4 (8%)
Renal tubule, necrosis	1 (2%)	2 (4%)		
Urinary bladder	(50)	(50)	(50)	(50)
Inflammation				1 (2%)
Transitional epithelium, hyperplasia			1 (2%)	

APPENDIX D
SUMMARY OF LESIONS IN FEMALE MICE
IN THE 2-YEAR INHALATION STUDY
OF VANADIUM PENTOXIDE

TABLE D1	Summary of the Incidence of Neoplasms in Female Mice in the 2-Year Inhalation Study of Vanadium Pentoxide	226
TABLE D2	Individual Animal Tumor Pathology of Female Mice in the 2-Year Inhalation Study of Vanadium Pentoxide	230
TABLE D3	Statistical Analysis of Primary Neoplasms in Female Mice in the 2-Year Inhalation Study of Vanadium Pentoxide	254
TABLE D4	Historical Incidence of Alveolar/bronchiolar Neoplasms in Control Female B6C3F₁ Mice	257
TABLE D5	Summary of the Incidence of Nonneoplastic Lesions in Female Mice in the 2-Year Inhalation Study of Vanadium Pentoxide	258

TABLE D1
Summary of the Incidence of Neoplasms in Female Mice in the 2-Year Inhalation Study of Vanadium Pentoxide^a

	Chamber Control	1 mg/m ³	2 mg/m ³	4 mg/m ³
Disposition Summary				
Animals initially in study	50	50	50	50
Accidental deaths		3	2	
Moribund	8	10	14	16
Natural deaths	4	5	4	2
Survivors				
Died last week of study			1	
Terminal sacrifice	38	32	29	32
Animals examined microscopically	50	50	50	50
Alimentary System				
Intestine large, cecum	(47)	(44)	(48)	(49)
Leiomyosarcoma		1 (2%)		
Intestine small, duodenum	(47)	(43)	(46)	(49)
Polyp adenomatous	1 (2%)			
Intestine small, jejunum	(47)	(43)	(45)	(50)
Histiocytic sarcoma	1 (2%)			
Intestine small, ileum	(47)	(43)	(46)	(50)
Histiocytic sarcoma			1 (2%)	
Liver	(50)	(50)	(50)	(50)
Alveolar/bronchiolar carcinoma, metastatic, lung				1 (2%)
Hepatocellular carcinoma	6 (12%)	3 (6%)	4 (8%)	6 (12%)
Hepatocellular carcinoma, multiple		1 (2%)		
Hepatocellular adenoma	5 (10%)	5 (10%)	9 (18%)	1 (2%)
Hepatocellular adenoma, multiple	1 (2%)	2 (4%)		1 (2%)
Histiocytic sarcoma	2 (4%)	1 (2%)	1 (2%)	1 (2%)
Squamous cell carcinoma, metastatic, stomach, forestomach			1 (2%)	
Mesentery	(14)	(9)	(5)	(4)
Fat, hemangioma			1 (20%)	
Fat, schwannoma malignant, metastatic, uterus				1 (25%)
Oral mucosa				(1)
Squamous cell carcinoma				1 (100%)
Pancreas	(50)	(50)	(49)	(50)
Histiocytic sarcoma	2 (4%)			1 (2%)
Salivary glands	(50)	(50)	(50)	(50)
Stomach, forestomach	(50)	(50)	(50)	(50)
Squamous cell carcinoma			1 (2%)	
Squamous cell papilloma	2 (4%)			
Stomach, glandular	(49)	(47)	(48)	(50)
Cardiovascular System				
Heart	(50)	(50)	(50)	(50)
Alveolar/bronchiolar carcinoma, metastatic, lung		1 (2%)		
Histiocytic sarcoma	1 (2%)	1 (2%)		
Pericardium, alveolar/bronchiolar carcinoma, metastatic, lung		1 (2%)		1 (2%)

TABLE D1
Summary of the Incidence of Neoplasms in Female Mice in the 2-Year Inhalation Study of Vanadium Pentoxide

	Chamber Control	1 mg/m ³	2 mg/m ³	4 mg/m ³
Endocrine System				
Adrenal cortex	(50)	(50)	(49)	(49)
Adrenal medulla	(49)	(50)	(48)	(49)
Pheochromocytoma benign	2 (4%)			3 (6%)
Pituitary gland	(49)	(50)	(50)	(47)
Histiocytic sarcoma	1 (2%)			
Pars distalis, adenoma	8 (16%)	6 (12%)	7 (14%)	3 (6%)
Thyroid gland	(50)	(50)	(48)	(50)
Bilateral, follicular cell, adenoma		1 (2%)		
C-cell, carcinoma				1 (2%)
General Body System				
Peritoneum				(1)
Schwannoma malignant, metastatic, uterus				1 (100%)
Tissue NOS	(1)			
Abdominal, histiocytic sarcoma	1 (100%)			
Genital System				
Ovary	(48)	(50)	(49)	(47)
Cystadenoma	1 (2%)		1 (2%)	2 (4%)
Granulosa cell tumor malignant			1 (2%)	
Histiocytic sarcoma	2 (4%)	1 (2%)	1 (2%)	
Uterus	(50)	(49)	(49)	(50)
Hemangioma			1 (2%)	
Hemangiosarcoma				1 (2%)
Histiocytic sarcoma	2 (4%)	1 (2%)		1 (2%)
Polyp stromal	1 (2%)	2 (4%)	3 (6%)	1 (2%)
Polyp stromal, multiple	1 (2%)			
Sarcoma stromal			1 (2%)	
Schwannoma malignant, metastatic, uterus				1 (2%)
Hematopoietic System				
Bone marrow	(50)	(50)	(50)	(50)
Hemangiosarcoma	1 (2%)			1 (2%)
Histiocytic sarcoma	1 (2%)		1 (2%)	
Lymph node	(3)	(1)	(5)	(1)
Iliac, histiocytic sarcoma			1 (20%)	
Pancreatic, histiocytic sarcoma			1 (20%)	
Renal, histiocytic sarcoma			1 (20%)	
Lymph node, bronchial	(39)	(40)	(45)	(41)
Alveolar/bronchiolar carcinoma, metastatic, lung		1 (3%)		1 (2%)
Histiocytic sarcoma		1 (3%)		1 (2%)
Lymph node, mandibular	(41)	(40)	(40)	(46)
Histiocytic sarcoma	1 (2%)	1 (3%)	1 (3%)	1 (2%)
Lymph node, mesenteric	(46)	(47)	(48)	(50)
Fibrous histiocytoma	1 (2%)			
Histiocytic sarcoma	1 (2%)	1 (2%)	1 (2%)	1 (2%)
Schwannoma malignant, metastatic, uterus				1 (2%)

TABLE D1
Summary of the Incidence of Neoplasms in Female Mice in the 2-Year Inhalation Study of Vanadium Pentoxide

	Chamber Control	1 mg/m ³	2 mg/m ³	4 mg/m ³
Hematopoietic System (continued)				
Lymph node, mediastinal	(43)	(37)	(42)	(42)
Alveolar/bronchiolar carcinoma, metastatic, lung		1 (3%)		1 (2%)
Histiocytic sarcoma	1 (2%)	1 (3%)	1 (2%)	1 (2%)
Spleen	(50)	(48)	(49)	(50)
Hemangiosarcoma	2 (4%)		1 (2%)	2 (4%)
Histiocytic sarcoma	1 (2%)		1 (2%)	1 (2%)
Thymus	(44)	(45)	(44)	(41)
Alveolar/bronchiolar carcinoma, metastatic, lung		1 (2%)		
Integumentary System				
Mammary gland	(50)	(50)	(50)	(50)
Carcinoma	1 (2%)			
Skin	(50)	(50)	(50)	(50)
Subcutaneous tissue, hemangiosarcoma	1 (2%)		1 (2%)	
Subcutaneous tissue, histiocytic sarcoma	1 (2%)			
Subcutaneous tissue, sarcoma	2 (4%)		2 (4%)	2 (4%)
Musculoskeletal System				
Skeletal muscle		(1)		
Alveolar/bronchiolar carcinoma, metastatic, lung		1 (100%)		
Nervous System				
Brain	(50)	(50)	(50)	(50)
Histiocytic sarcoma	1 (2%)		1 (2%)	
Respiratory System				
Larynx	(50)	(50)	(49)	(50)
Lung	(50)	(50)	(50)	(50)
Alveolar/bronchiolar adenoma	1 (2%)	14 (28%)	18 (36%)	13 (26%)
Alveolar/bronchiolar adenoma, multiple		3 (6%)	5 (10%)	6 (12%)
Alveolar/bronchiolar carcinoma		14 (28%)	13 (26%)	17 (34%)
Alveolar/bronchiolar carcinoma, multiple		9 (18%)	5 (10%)	5 (10%)
Granular cell tumor malignant, metastatic, ovary			1 (2%)	
Hepatocellular carcinoma, metastatic, liver	2 (4%)		1 (2%)	1 (2%)
Histiocytic sarcoma	1 (2%)	1 (2%)	1 (2%)	1 (2%)
Sarcoma, metastatic, skin				1 (2%)
Mediastinum, alveolar/bronchiolar carcinoma, metastatic, lung		2 (4%)		2 (4%)
Nose	(50)	(50)	(50)	(50)
Histiocytic sarcoma	1 (2%)			
Special Senses System				
Harderian gland	(3)	(1)	(1)	
Adenoma		1 (100%)	1 (100%)	
Bilateral, adenoma	2 (67%)			

TABLE D1
Summary of the Incidence of Neoplasms in Female Mice in the 2-Year Inhalation Study of Vanadium Pentoxide

	Chamber Control	1 mg/m ³	2 mg/m ³	4 mg/m ³
Urinary System				
Kidney	(50)	(50)	(49)	(50)
Carcinoma				1 (2%)
Histiocytic sarcoma	1 (2%)		1 (2%)	1 (2%)
Urinary bladder	(48)	(45)	(48)	(49)
Systemic Lesions				
Multiple organs ^b	(50)	(50)	(50)	(50)
Histiocytic sarcoma	3 (6%)	1 (2%)	1 (2%)	1 (2%)
Lymphoma malignant	7 (14%)	4 (8%)	12 (24%)	5 (10%)
Neoplasm Summary				
Total animals with primary neoplasms ^c	32	37	44	40
Total primary neoplasms	49	67	88	73
Total animals with benign neoplasms	19	23	35	27
Total benign neoplasms	25	34	46	30
Total animals with malignant neoplasms	17	29	32	32
Total malignant neoplasms	24	33	42	43
Total animals with metastatic neoplasms	2	2	3	5
Total metastatic neoplasms	2	8	3	12

^a Number of animals examined microscopically at the site and the number of animals with neoplasm

^b Number of animals with any tissue examined microscopically

^c Primary neoplasms: all neoplasms except metastatic neoplasms

**TABLE D2
Individual Animal Tumor Pathology of Female Mice in the 2-Year Inhalation Study of Vanadium Pentoxide:
Chamber Control**

Number of Days on Study	0	1	5	6	6	6	6	6	6	6	7	7	7	7	7	7	7	7	7	7	7	7	7	7	
	1	8	0	2	4	6	8	8	8	9	0	1	3	3	3	3	3	3	3	3	3	3	3	3	
	6	1	5	6	2	2	1	3	6	5	9	5	1	1	1	1	1	1	1	2	2	2	2	2	
Carcass ID Number	1	1	1	1	1	1	1	1	1	1	1	1	1	1	1	1	1	1	1	1	1	1	1	1	
	2	3	4	4	5	4	0	1	4	1	3	3	0	1	2	2	2	2	3	0	1	1	1	1	
	2	5	7	5	0	1	8	5	4	1	3	7	3	3	0	1	5	9	4	5	0	4	6	7	9
Alimentary System																									
Esophagus	+	+	+	+	+	+	+	+	+	+	+	+	+	+	+	+	+	+	+	+	+	+	+	+	
Gallbladder	A	A	+	+	M	+	+	+	+	+	+	+	+	+	+	+	+	+	+	+	M	+	+	+	
Intestine large, colon	A	A	+	+	+	+	+	+	+	+	+	+	+	+	+	+	+	+	+	+	+	+	+	+	
Intestine large, rectum	+	+	+	+	+	+	+	+	+	+	+	M	+	+	+	+	+	+	+	+	+	+	+	+	
Intestine large, cecum	A	A	+	+	A	+	+	+	+	+	+	+	+	+	+	+	+	+	+	+	+	+	+	+	
Intestine small, duodenum	A	A	+	+	A	+	+	+	+	+	+	+	+	+	+	+	+	+	+	+	+	+	+	+	
Polyp adenomatous										X															
Intestine small, jejunum	A	A	+	+	A	+	+	+	+	+	+	+	+	+	+	+	+	+	+	+	+	+	+	+	
Histiocytic sarcoma												X													
Intestine small, ileum	A	A	+	+	A	+	+	+	+	+	+	+	+	+	+	+	+	+	+	+	+	+	+	+	
Liver	+	+	+	+	+	+	+	+	+	+	+	+	+	+	+	+	+	+	+	+	+	+	+	+	
Hepatocellular carcinoma										X										X					
Hepatocellular adenoma			X																					X	
Hepatocellular adenoma, multiple																									
Histiocytic sarcoma										X	X														
Mesentery				+							+							+				+			
Pancreas	+	+	+	+	+	+	+	+	+	+	+	+	+	+	+	+	+	+	+	+	+	+	+	+	
Histiocytic sarcoma											X	X													
Salivary glands	+	+	+	+	+	+	+	+	+	+	+	+	+	+	+	+	+	+	+	+	+	+	+	+	
Stomach, forestomach	+	+	+	+	+	+	+	+	+	+	+	+	+	+	+	+	+	+	+	+	+	+	+	+	
Squamous cell papilloma											X														
Stomach, glandular	+	+	+	+	A	+	+	+	+	+	+	+	+	+	+	+	+	+	+	+	+	+	+	+	
Cardiovascular System																									
Heart	+	+	+	+	+	+	+	+	+	+	+	+	+	+	+	+	+	+	+	+	+	+	+	+	
Histiocytic sarcoma												X													
Endocrine System																									
Adrenal cortex	+	+	+	+	+	+	+	+	+	+	+	+	+	+	+	+	+	+	+	+	+	+	+	+	
Adrenal medulla	+	+	M	+	+	+	+	+	+	+	+	+	+	+	+	+	+	+	+	+	+	+	+	+	
Pheochromocytoma benign																									
Islets, pancreatic	+	+	+	+	+	+	+	+	+	+	+	+	+	+	+	+	+	+	+	+	+	+	+	+	
Parathyroid gland	+	+	+	+	+	M	+	+	+	+	I	M	+	+	+	+	+	+	+	+	+	+	+	+	
Pituitary gland	+	M	+	+	+	+	+	+	+	+	+	+	+	+	+	+	+	+	+	+	+	+	+	+	
Histiocytic sarcoma												X													
Pars distalis, adenoma										X	X									X					
Thyroid gland	+	+	+	+	+	+	+	+	+	+	+	+	+	+	+	+	+	+	+	+	+	+	+	+	
General Body System																									
Tissue NOS											+														
Abdominal, histiocytic sarcoma											X														

+ : Tissue examined microscopically
A : Autolysis precludes examination

M: Missing tissue
I: Insufficient tissue

X: Lesion present
Blank: Not examined

TABLE D2
Individual Animal Tumor Pathology of Female Mice in the 2-Year Inhalation Study of Vanadium Pentoxide: Chamber Control

Table with 15 columns of numerical data (days on study, carcass ID numbers) and rows detailing tumor pathology for various organs (Genital System, Hematopoietic System, Integumentary System, Musculoskeletal System, Nervous System) across different tissues.

TABLE D2
Individual Animal Tumor Pathology of Female Mice in the 2-Year Inhalation Study of Vanadium Pentoxide: 1 mg/m³

Number of Days on Study	7 7
	3 3
	1 2 2 2 2 2 2 2 2 2 2 2 2 2 2 2 3 3 3 3 3 3 3
Carcass ID Number	3 3
	4 0 1 1 1 2 2 2 2 3 3 3 3 4 4 4 0 0 0 1 2 3 4 4 5
	5 1 5 6 7 0 2 8 9 0 2 4 6 0 7 8 3 6 9 9 4 7 3 9 0
	Total Tissues/ Tumors
Alimentary System	
Esophagus	+ +
Gallbladder	+ + M M +
Intestine large, colon	+ +
Intestine large, rectum	+ +
Intestine large, cecum	+ +
Leiomyosarcoma	
Intestine small, duodenum	+ +
Intestine small, jejunum	+ +
Intestine small, ileum	+ +
Liver	+ +
Hepatocellular carcinoma	
Hepatocellular carcinoma, multiple	
Hepatocellular adenoma	
Hepatocellular adenoma, multiple	
Histiocytic sarcoma	
Mesentery	+ + + + +
Pancreas	+ +
Salivary glands	+ +
Stomach, forestomach	+ +
Stomach, glandular	+ +
Cardiovascular System	
Heart	+ +
Alveolar/bronchiolar carcinoma, metastatic, lung	
Histiocytic sarcoma	
Pericardium, alveolar/bronchiolar carcinoma, metastatic, lung	
Endocrine System	
Adrenal cortex	+ +
Adrenal medulla	+ +
Islets, pancreatic	+ +
Parathyroid gland	+ + + + + + + + + M + + + + + + + + + + + + + +
Pituitary gland	+ +
Pars distalis, adenoma	
Thyroid gland	+ +
Bilateral, follicular cell, adenoma	
General Body System	
None	

TABLE D2
Individual Animal Tumor Pathology of Female Mice in the 2-Year Inhalation Study of Vanadium Pentoxide: 1 mg/m³

Number of Days on Study	0 0 0 4 5 5 5 5 6 6 6 6 6 6 6 7 7 7 7 7 7 7 7 7
	2 2 2 4 2 3 6 8 0 1 3 5 6 6 6 0 1 2 3 3 3 3 3 3 3
	3 3 3 6 2 0 4 4 3 0 5 4 0 0 8 5 8 6 1 1 1 1 1 1 1
Carcass ID Number	3 3
	0 0 0 1 3 1 1 2 0 4 2 3 1 2 0 1 2 4 1 2 3 3 3 4 4
	4 5 7 0 3 2 4 7 8 4 3 5 3 1 2 8 5 6 1 6 1 8 9 1 2
Respiratory System	
Larynx	+ +
Lung	+ +
Alveolar/bronchiolar adenoma	X X X X X X X X X
Alveolar/bronchiolar adenoma, multiple	X X X X X X X
Alveolar/bronchiolar carcinoma	X X X X X X X
Alveolar/bronchiolar carcinoma, multiple	X X X X X X X
Histiocytic sarcoma	X
Mediastinum, alveolar/bronchiolar carcinoma, metastatic, lung	X X
Nose	+ +
Pleura	+
Trachea	+ +
Special Senses System	
Harderian gland	
Adenoma	
Urinary System	
Kidney	+ +
Urinary bladder	A A A +
Systemic Lesions	
Multiple organs	+ +
Histiocytic sarcoma	X
Lymphoma malignant	X X X

TABLE D2
Individual Animal Tumor Pathology of Female Mice in the 2-Year Inhalation Study of Vanadium Pentoxide: 1 mg/m³

Number of Days on Study	7 7	
	3 3	
	1 2 2 2 2 2 2 2 2 2 2 2 2 2 2 2 3 3 3 3 3 3 3 3	
Carcass ID Number	3 3	Total Tissues/ Tumors
	4 0 1 1 1 2 2 2 2 3 3 3 3 4 4 4 0 0 0 1 2 3 4 4 5	
	5 1 5 6 7 0 2 8 9 0 2 4 6 0 7 8 3 6 9 9 4 7 3 9 0	
Respiratory System		
Larynx	+ +	50
Lung	+ +	50
Alveolar/bronchiolar adenoma	X X X X X	14
Alveolar/bronchiolar adenoma, multiple		3
Alveolar/bronchiolar carcinoma	X X X X X X X X X	14
Alveolar/bronchiolar carcinoma, multiple		9
Histiocytic sarcoma		1
Mediastinum, alveolar/bronchiolar carcinoma, metastatic, lung		2
Nose	+ +	50
Pleura		1
Trachea	+ +	49
Special Senses System		
Harderian gland		1
Adenoma		1
Urinary System		
Kidney	+ +	50
Urinary bladder	+ +	45
Systemic Lesions		
Multiple organs	+ +	50
Histiocytic sarcoma		1
Lymphoma malignant		4

TABLE D2
Individual Animal Tumor Pathology of Female Mice in the 2-Year Inhalation Study of Vanadium Pentoxide: 2 mg/m³

Number of Days on Study	7 7			
	3 3			
	1 2 2 2 2 2 2 2 2 2 2 3 3 3 3 3 3 3 3 3 3 3			
Carcass ID Number	5 5			Total
	3 1 1 2 2 2 3 3 3 3 3 4 0 1 2 2 2 3 3 4 4 4 4			Tissues/ Tumors
	8 4 9 0 2 8 1 2 4 7 2 3 3 4 7 9 3 9 1 3 4 7 8 9 0			
Genital System				
Clitoral gland	+ + + + M + M + + M + M + + M + + + M + + + + + + + +			39
Ovary	+ +			49
Cystadenoma				1
Granulosa cell tumor malignant				1
Histiocytic sarcoma				1
Uterus	+ +			49
Hemangioma				1
Polyp stromal			X	3
Sarcoma stromal				1
Hematopoietic System				
Bone marrow	+ +			50
Histiocytic sarcoma				1
Lymph node		+		5
Iliac, histiocytic sarcoma			+	1
Pancreatic, histiocytic sarcoma				1
Renal, histiocytic sarcoma				1
Lymph node, bronchial	+ + + + + + M + + + M + + + + + + + + + + + + + +			45
Lymph node, mandibular	+ + + + + + M + M + M + M M + + + + + + M + + + + +			40
Histiocytic sarcoma				1
Lymph node, mesenteric	+ +			48
Histiocytic sarcoma				1
Lymph node, mediastinal	+ + + + + + + + + + + + + + M + + + + + + + + + + +			42
Histiocytic sarcoma				1
Spleen	+ +			49
Hemangiosarcoma			X	1
Histiocytic sarcoma				1
Thymus	+ + + + + + M + + + + + + + + + + + + + + M + + + + + +			44
Integumentary System				
Mammary gland	+ +			50
Skin	+ +			50
Subcutaneous tissue, hemangiosarcoma			X	1
Subcutaneous tissue, sarcoma				2
Musculoskeletal System				
Bone	+ +			50
Nervous System				
Brain	+ +			50
Histiocytic sarcoma				1

**TABLE D2
Individual Animal Tumor Pathology of Female Mice in the 2-Year Inhalation Study of Vanadium Pentoxide: 2 mg/m³**

Number of Days on Study	7 7	
	3 3	
	1 2 2 2 2 2 2 2 2 2 2 2 3 3 3 3 3 3 3 3 3 3 3	

Carcass ID Number	5 5	Total
	3 1 1 2 2 2 3 3 3 3 4 0 1 2 2 2 3 3 4 4 4 4 4 5	Tissues/ Tumors
	8 4 9 0 2 8 1 2 4 7 2 3 3 4 7 9 3 9 1 3 4 7 8 9 0	

Respiratory System		
Larynx	+ +	49
Lung	+ +	50
Alveolar/bronchiolar adenoma	X X X X X X X X X X	18
Alveolar/bronchiolar adenoma, multiple		5
Alveolar/bronchiolar carcinoma	X X X X X X X X X	13
Alveolar/bronchiolar carcinoma, multiple		5
Granular cell tumor malignant, metastatic, ovary		1
Hepatocellular carcinoma, metastatic, liver		1
Histiocytic sarcoma		1
Nose	+ +	50
Trachea	+ +	47
Special Senses System		
Eye		1
Harderian gland		1
Adenoma		1
Urinary System		
Kidney	+ +	49
Histiocytic sarcoma		1
Urinary bladder	+ +	48
Systemic Lesions		
Multiple organs	+ +	50
Histiocytic sarcoma		1
Lymphoma malignant	X X X X X X	12

TABLE D2
Individual Animal Tumor Pathology of Female Mice in the 2-Year Inhalation Study of Vanadium Pentoxide: 4 mg/m³

Number of Days on Study	7 3 2 2 2 2 2 2 2 2 2 2 2 2 2 2 2 3 3 3 3 3 3 3	Carcass ID Number	7 0 1 1 2 2 2 2 3 3 3 4 4 4 0 0 0 0 1 1 2 2 2 3 4 5 7 1 2 0 3 8 9 4 7 8 2 3 6 2 3 4 5 3 6 2 4 6 5 4 0	Total Tissues/ Tumors																					
Respiratory System																									
Larynx	+	+	+	+	+	+	+	+	+	+	+	+	+	+	+	+	+	+	+	+	+	+	+	+	50
Lung	+	+	+	+	+	+	+	+	+	+	+	+	+	+	+	+	+	+	+	+	+	+	+	+	50
Alveolar/bronchiolar adenoma	X					X			X	X	X	X	X										X		13
Alveolar/bronchiolar adenoma, multiple				X									X		X						X	X			6
Alveolar/bronchiolar carcinoma					X				X								X	X							17
Alveolar/bronchiolar carcinoma, multiple	X		X						X													X			5
Hepatocellular carcinoma, metastatic, liver																									1
Histiocytic sarcoma									X																1
Sarcoma, metastatic, skin														X											1
Mediastinum, alveolar/bronchiolar carcinoma, metastatic, lung																									2
Nose	+	+	+	+	+	+	+	+	+	+	+	+	+	+	+	+	+	+	+	+	+	+	+	+	50
Pleura																							+		1
Trachea	+	+	+	+	+	+	+	+	+	+	+	+	+	+	+	+	+	+	+	+	+	+	+	+	50
Special Senses System																									
None																									
Urinary System																									
Kidney	+	+	+	+	+	+	+	+	+	+	+	+	+	+	+	+	+	+	+	+	+	+	+	+	50
Carcinoma																							X		1
Histiocytic sarcoma									X																1
Urinary bladder	+	+	+	+	+	+	+	+	+	+	+	+	+	+	+	+	+	+	+	+	+	+	+	+	49
Systemic Lesions																									
Multiple organs	+	+	+	+	+	+	+	+	+	+	+	+	+	+	+	+	+	+	+	+	+	+	+	+	50
Histiocytic sarcoma									X																1
Lymphoma malignant																						X	X		5

TABLE D3
Statistical Analysis of Primary Neoplasms in Female Mice in the 2-Year Inhalation Study of Vanadium Pentoxide

	Chamber Control	1 mg/m ³	2 mg/m ³	4 mg/m ³
Adrenal Medulla: Benign Pheochromocytoma				
Overall rate ^a	2/49 (4%)	0/50 (0%)	0/48 (0%)	3/49 (6%)
Adjusted rate ^b	4.4%	0.0%	0.0%	7.1%
Terminal rate ^c	2/38 (5%)	0/32 (0%)	0/30 (0%)	2/31 (7%)
First incidence (days) ^d	731 (T)	— ^e	—	728
Poly-3 test	P=0.244	P=0.257N	P=0.269N	P=0.472
Liver: Hepatocellular Adenoma				
Overall rate	6/50 (12%)	7/50 (14%)	9/50 (18%)	2/50 (4%)
Adjusted rate	13.0%	16.6%	21.4%	4.6%
Terminal rate	5/38 (13%)	6/32 (19%)	4/30 (13%)	1/32 (3%)
First incidence (days)	505	564	416	705
Poly-3 test	P=0.137N	P=0.427	P=0.223	P=0.152N
Liver: Hepatocellular Carcinoma				
Overall rate	6/50 (12%)	4/50 (8%)	4/50 (8%)	6/50 (12%)
Adjusted rate	13.1%	9.6%	9.9%	13.7%
Terminal rate	5/38 (13%)	2/32 (6%)	3/30 (10%)	3/32 (9%)
First incidence (days)	686	660	639	695
Poly-3 test	P=0.482	P=0.427N	P=0.451N	P=0.588
Liver: Hepatocellular Adenoma or Carcinoma				
Overall rate	12/50 (24%)	10/50 (20%)	13/50 (26%)	8/50 (16%)
Adjusted rate	25.9%	23.6%	30.6%	18.3%
Terminal rate	10/38 (26%)	7/32 (22%)	7/30 (23%)	4/32 (13%)
First incidence (days)	505	564	416	695
Poly-3 test	P=0.265N	P=0.501N	P=0.398	P=0.270N
Lung: Alveolar/bronchiolar Adenoma				
Overall rate	1/50 (2%)	17/50 (34%)	23/50 (46%)	19/50 (38%)
Adjusted rate	2.2%	38.7%	51.5%	42.2%
Terminal rate	1/38 (3%)	9/32 (28%)	13/30 (43%)	14/32 (44%)
First incidence (days)	731 (T)	530	281	478
Poly-3 test	P<0.001	P<0.001	P<0.001	P<0.001
Lung: Alveolar/bronchiolar Carcinoma				
Overall rate	0/50 (0%)	23/50 (46%)	18/50 (36%)	22/50 (44%)
Adjusted rate	0.0%	52.3%	44.7%	47.9%
Terminal rate	0/38 (0%)	15/32 (47%)	15/30 (50%)	12/32 (38%)
First incidence (days)	—	522	695	542
Poly-3 test	P<0.001	P<0.001	P<0.001	P<0.001
Lung: Alveolar/bronchiolar Adenoma or Carcinoma				
Overall rate	1/50 (2%)	32/50 (64%)	35/50 (70%)	32/50 (64%)
Adjusted rate	2.2%	70.3%	78.0%	68.1%
Terminal rate	1/38 (3%)	20/32 (63%)	23/30 (77%)	20/32 (63%)
First incidence (days)	731 (T)	522	281	478
Poly-3 test	P<0.001	P<0.001	P<0.001	P<0.001
Pituitary Gland (Pars Distalis): Adenoma				
Overall rate	8/49 (16%)	6/50 (12%)	7/50 (14%)	3/47 (6%)
Adjusted rate	17.5%	14.2%	17.5%	7.2%
Terminal rate	6/38 (16%)	2/32 (6%)	6/30 (20%)	2/30 (7%)
First incidence (days)	695	654	705	550
Poly-3 test	P=0.117N	P=0.450N	P=0.611N	P=0.130N

TABLE D3
Statistical Analysis of Primary Neoplasms in Female Mice in the 2-Year Inhalation Study of Vanadium Pentoxide

	Chamber Control	1 mg/m ³	2 mg/m ³	4 mg/m ³
Uterus: Stromal Polyp				
Overall rate	2/50 (4%)	2/50 (4%)	3/50 (6%)	1/50 (2%)
Adjusted rate	4.4%	4.8%	7.5%	2.3%
Terminal rate	1/38 (3%)	2/32 (6%)	3/30 (10%)	1/32 (3%)
First incidence (days)	683	731 (T)	731 (T)	731 (T)
Poly-3 test	P=0.420N	P=0.659	P=0.439	P=0.518N
Uterus: Stromal Polyp or Stromal Sarcoma				
Overall rate	2/50 (4%)	2/50 (4%)	4/50 (8%)	1/50 (2%)
Adjusted rate	4.4%	4.8%	9.8%	2.3%
Terminal rate	1/38 (3%)	2/32 (6%)	3/30 (10%)	1/32 (3%)
First incidence (days)	683	731 (T)	416	731 (T)
Poly-3 test	P=0.448N	P=0.659	P=0.286	P=0.518N
All Organs: Hemangiosarcoma				
Overall rate	2/50 (4%)	0/50 (0%)	1/50 (2%)	3/50 (6%)
Adjusted rate	4.4%	0.0%	2.5%	6.8%
Terminal rate	1/38 (3%)	0/32 (0%)	1/30 (3%)	1/32 (3%)
First incidence (days)	626	—	731 (T)	611
Poly-3 test	P=0.245	P=0.260N	P=0.548N	P=0.482
All Organs: Hemangioma or Hemangiosarcoma				
Overall rate	2/50 (4%)	0/50 (0%)	3/50 (6%)	3/50 (6%)
Adjusted rate	4.4%	0.0%	7.5%	6.8%
Terminal rate	1/38 (3%)	0/32 (0%)	2/30 (7%)	1/32 (3%)
First incidence (days)	626	—	662	611
Poly-3 test	P=0.235	P=0.260N	P=0.440	P=0.482
All Organs: Histiocytic Sarcoma				
Overall rate	3/50 (6%)	1/50 (2%)	1/50 (2%)	1/50 (2%)
Adjusted rate	6.6%	2.4%	2.5%	2.3%
Terminal rate	1/38 (3%)	0/32 (0%)	0/30 (0%)	1/32 (3%)
First incidence (days)	695	530	725	731 (T)
Poly-3 test	P=0.247N	P=0.335N	P=0.355N	P=0.324N
All Organs: Malignant Lymphoma				
Overall rate	7/50 (14%)	4/50 (8%)	12/50 (24%)	5/50 (10%)
Adjusted rate	15.4%	9.5%	28.5%	11.3%
Terminal rate	7/38 (18%)	2/32 (6%)	7/30 (23%)	2/32 (6%)
First incidence (days)	731 (T)	603	270	611
Poly-3 test	P=0.505N	P=0.306N	P=0.107	P=0.400N
All Organs: Benign Neoplasms				
Overall rate	19/50 (38%)	23/50 (46%)	35/50 (70%)	27/50 (54%)
Adjusted rate	40.7%	51.7%	76.8%	58.9%
Terminal rate	15/38 (40%)	14/32 (44%)	23/30 (77%)	19/32 (59%)
First incidence (days)	505	530	281	478
Poly-3 test	P=0.027	P=0.199	P<0.001	P=0.058
All Organs: Malignant Neoplasms				
Overall rate	17/50 (34%)	29/50 (58%)	32/50 (64%)	33/50 (66%)
Adjusted rate	36.4%	63.6%	73.2%	68.0%
Terminal rate	11/38 (29%)	17/32 (53%)	21/30 (70%)	17/32 (53%)
First incidence (days)	626	522	270	478
Poly-3 test	P=0.002	P=0.007	P<0.001	P<0.001

TABLE D3
Statistical Analysis of Primary Neoplasms in Female Mice in the 2-Year Inhalation Study of Vanadium Pentoxide

	Chamber Control	1 mg/m ³	2 mg/m ³	4 mg/m ³
All Organs: Benign or Malignant Neoplasms				
Overall rate	32/50 (64%)	37/50 (74%)	44/50 (88%)	40/50 (80%)
Adjusted rate	67.1%	80.0%	92.9%	82.5%
Terminal rate	23/38 (61%)	23/32 (72%)	28/30 (93%)	24/32 (75%)
First incidence (days)	505	522	270	478
Poly-3 test	P=0.038	P=0.116	P<0.001	P=0.064

(T) Terminal sacrifice

^a Number of neoplasm-bearing animals/number of animals examined. Denominator is number of animals examined microscopically for adrenal gland, liver, lung, and pituitary gland; for other tissues, denominator is number of animals necropsied.

^b Poly-3 estimated neoplasm incidence after adjustment for intercurrent mortality

^c Observed incidence at terminal kill

^d Beneath the chamber control incidence is the P value associated with the trend test. Beneath the exposed group incidence are the P values corresponding to pairwise comparisons between the chamber controls and that exposed group. The Poly-3 test accounts for the differential mortality in animals that do not reach terminal sacrifice. A negative trend or a lower incidence in an exposure group is indicated by N.

^e Not applicable; no neoplasms in animal group

TABLE D4
Historical Incidence of Alveolar/bronchiolar Neoplasms in Control Female B6C3F₁ Mice

	Incidence in Controls		
	Adenoma	Carcinoma	Adenoma or Carcinoma
Historical Incidence in Controls Given NTP-2000 Diet^a			
Acrylonitrile (gavage)	4/50	2/50	6/50
Citral (feed)	5/99	6/99	11/99
<i>p,p'</i> -Dichlorodiphenyl sulfone (feed)	0/50	0/50	0/50
Indium phosphide (inhalation)	3/50	1/50	4/50
60-Hz Magnetic fields (whole body exposure)	9/95	2/95	11/95
Methacrylonitrile (gavage)	6/50	1/50	6/50
<i>o</i> -Nitrotoluene (feed)	2/60	3/60	5/60
<i>p</i> -Nitrotoluene (feed)	5/50	1/50	6/50
Riddelliine (gavage)	1/50	1/50	2/50
Sodium nitrite (drinking water)	1/50	0/50	1/50
Vanadium pentoxide (inhalation)	1/50	0/50	1/50
Overall Historical Incidence in Controls Given NTP-2000 Diet			
Total (%)	37/654 (5.7%)	17/654 (2.6%)	53/654 (8.1%)
Mean ± standard deviation	5.4% ± 4.0%	2.3% ± 2.0%	7.6% ± 4.7%
Range	0%-12%	0%-6%	0%-12%
Historical Incidence in Chamber Controls Given NIH-07 Diet at Battelle Pacific Northwest Laboratories^b			
Acetonitrile	7/49	1/49	8/49
1,3-Butadiene	4/50	0/50	4/50
2-Butoxyethanol	7/50	0/50	7/50
Chloroprene	2/50	2/50	4/50
Cobalt sulfate heptahydrate	3/50	1/50	4/50
Furfuryl alcohol	2/50	4/50	6/50
Gallium arsenide	6/50	1/50	7/50
Glutaraldehyde	2/50	1/50	3/50
Hexachlorocyclopentadiene	4/48	3/48	7/48
Isobutene	2/49	4/49	6/49
Isobutyraldehyde	0/50	3/50	3/50
Molybdenum trioxide	1/50	2/50	3/50
Nitromethane	3/50	0/50	3/50
Ozone	4/50	2/50	6/50
Tetrahydrofuran	1/50	1/50	2/50
Overall Historical Incidence in Chamber Controls Given NIH-07 Diet			
Total (%)	67/1,075 (6.2%)	43/1,075 (4.0%)	109/1,075 (10.1%)
Mean ± standard deviation	6.3% ± 3.7%	3.9% ± 3.2%	10.1% ± 3.6%
Range	0%-14%	0%-12%	4%-16%

^a Data as of December 20, 2000

^b Data as of December 23, 1999

TABLE D5
Summary of the Incidence of Nonneoplastic Lesions in Female Mice in the 2-Year Inhalation Study of Vanadium Pentoxide^a

	Chamber Control	1 mg/m ³	2 mg/m ³	4 mg/m ³
Disposition Summary				
Animals initially in study	50	50	50	50
Accidental deaths		3	2	
Moribund	8	10	14	16
Natural deaths	4	5	4	2
Survivors				
Died last week of study			1	
Terminal sacrifice	38	32	29	32
Animals examined microscopically	50	50	50	50
Alimentary System				
Gallbladder	(46)	(41)	(43)	(45)
Inflammation, suppurative	1 (2%)	1 (2%)		
Intestine small, duodenum	(47)	(43)	(46)	(49)
Inflammation, suppurative	1 (2%)	1 (2%)		
Ulcer		1 (2%)		
Epithelium, hyperplasia			1 (2%)	
Intestine small, jejunum	(47)	(43)	(45)	(50)
Inflammation		1 (2%)		
Intestine small, ileum	(47)	(43)	(46)	(50)
Inflammation, suppurative	1 (2%)	1 (2%)		
Ulcer	1 (2%)			
Liver	(50)	(50)	(50)	(50)
Angiectasis		1 (2%)	1 (2%)	
Basophilic focus				1 (2%)
Clear cell focus	1 (2%)			
Eosinophilic focus	12 (24%)	12 (24%)	3 (6%)	8 (16%)
Eosinophilic focus, multiple	4 (8%)	2 (4%)	1 (2%)	
Fatty change		1 (2%)		
Hematopoietic cell proliferation	4 (8%)		6 (12%)	3 (6%)
Infiltration cellular, mixed cell		1 (2%)		
Inflammation, focal, granulomatous	12 (24%)	26 (52%)	19 (38%)	21 (42%)
Necrosis, focal	2 (4%)	6 (12%)	9 (18%)	5 (10%)
Pigmentation, hemosiderin	1 (2%)		2 (4%)	
Tension lipodosis	2 (4%)	4 (8%)	1 (2%)	2 (4%)
Bile duct, cyst	1 (2%)	1 (2%)		1 (2%)
Centrilobular, degeneration		1 (2%)		
Centrilobular, inflammation, chronic		1 (2%)		
Centrilobular, necrosis	1 (2%)		1 (2%)	
Mesentery	(14)	(9)	(5)	(4)
Hemorrhage	1 (7%)			
Artery, inflammation	1 (7%)			
Fat, inflammation	1 (7%)	1 (11%)	1 (20%)	
Fat, necrosis	11 (79%)	9 (100%)	5 (100%)	3 (75%)
Pancreas	(50)	(50)	(49)	(50)
Atrophy	3 (6%)	4 (8%)	2 (4%)	4 (8%)
Duct, cyst				1 (2%)
Salivary glands	(50)	(50)	(50)	(50)
Amyloid deposition		1 (2%)		

^a Number of animals examined microscopically at the site and the number of animals with lesion

TABLE D5
Summary of the Incidence of Nonneoplastic Lesions in Female Mice in the 2-Year Inhalation Study of Vanadium Pentoxide

	Chamber Control	1 mg/m ³	2 mg/m ³	4 mg/m ³
Alimentary System (continued)				
Stomach, forestomach	(50)	(50)	(50)	(50)
Cyst				2 (4%)
Inflammation, suppurative			1 (2%)	1 (2%)
Mineralization				1 (2%)
Ulcer	1 (2%)	1 (2%)	2 (4%)	1 (2%)
Epithelium, hyperplasia	3 (6%)	1 (2%)	7 (14%)	1 (2%)
Stomach, glandular	(49)	(47)	(48)	(50)
Inflammation, suppurative		1 (2%)		1 (2%)
Mineralization		1 (2%)		
Ulcer	1 (2%)	1 (2%)	1 (2%)	
Epithelium, hyperplasia				1 (2%)
Tooth				(1)
Malformation				1 (100%)
Cardiovascular System				
Heart	(50)	(50)	(50)	(50)
Cardiomyopathy	47 (94%)	45 (90%)	46 (92%)	49 (98%)
Inflammation			1 (2%)	
Mineralization	2 (4%)	1 (2%)	1 (2%)	
Artery, inflammation	1 (2%)			
Capillary, hyperplasia	2 (4%)			
Endocrine System				
Adrenal cortex	(50)	(50)	(49)	(49)
Degeneration, cystic			2 (4%)	2 (4%)
Hypertrophy	5 (10%)	5 (10%)	3 (6%)	7 (14%)
Capsule, hyperplasia	1 (2%)			
Adrenal medulla	(49)	(50)	(48)	(49)
Hyperplasia	4 (8%)			
Islets, pancreatic	(50)	(50)	(49)	(50)
Hyperplasia		1 (2%)		
Parathyroid gland	(42)	(41)	(43)	(39)
Cyst		1 (2%)		
Hyperplasia		2 (5%)		1 (3%)
Pituitary gland	(49)	(50)	(50)	(47)
Pars distalis, cyst	2 (4%)		1 (2%)	2 (4%)
Pars distalis, hyperplasia	22 (45%)	26 (52%)	15 (30%)	20 (43%)
Thyroid gland	(50)	(50)	(48)	(50)
Inflammation, suppurative				2 (4%)
Follicular cell, cyst			1 (2%)	1 (2%)
Follicular cell, hyperplasia	1 (2%)	1 (2%)	1 (2%)	1 (2%)
General Body System				
None				

TABLE D5
Summary of the Incidence of Nonneoplastic Lesions in Female Mice in the 2-Year Inhalation Study of Vanadium Pentoxide

	Chamber Control	1 mg/m ³	2 mg/m ³	4 mg/m ³
Genital System				
Ovary	(48)	(50)	(49)	(47)
Angiectasis	1 (2%)	1 (2%)	1 (2%)	1 (2%)
Cyst	16 (33%)	16 (32%)	15 (31%)	17 (36%)
Hemorrhage		1 (2%)		
Thrombosis	1 (2%)	1 (2%)		
Uterus	(50)	(49)	(49)	(50)
Angiectasis	5 (10%)	4 (8%)	1 (2%)	
Hyperplasia, cystic	46 (92%)	43 (88%)	42 (86%)	41 (82%)
Inflammation	1 (2%)			
Inflammation, focal	1 (2%)			
Thrombosis		1 (2%)		
Myometrium, hyperplasia	1 (2%)			
Serosa, fibrosis				1 (2%)
Hematopoietic System				
Bone marrow	(50)	(50)	(50)	(50)
Hyperplasia	5 (10%)	1 (2%)	6 (12%)	6 (12%)
Lymph node	(3)	(1)	(5)	(1)
Angiectasis	3 (100%)	1 (100%)		
Lymph node, bronchial	(39)	(40)	(45)	(41)
Hyperplasia	3 (8%)	13 (33%)	14 (31%)	20 (49%)
Lymph node, mandibular	(41)	(40)	(40)	(46)
Hyperplasia		2 (5%)	1 (3%)	3 (7%)
Lymph node, mesenteric	(46)	(47)	(48)	(50)
Angiectasis				1 (2%)
Hyperplasia	2 (4%)	1 (2%)	1 (2%)	1 (2%)
Lymph node, mediastinal	(43)	(37)	(42)	(42)
Hyperplasia	6 (14%)	4 (11%)	5 (12%)	6 (14%)
Spleen	(50)	(48)	(49)	(50)
Hematopoietic cell proliferation	21 (42%)	12 (25%)	18 (37%)	11 (22%)
Hyperplasia, lymphoid	17 (34%)	18 (38%)	15 (31%)	15 (30%)
Thymus	(44)	(45)	(44)	(41)
Amyloid deposition		1 (2%)		
Angiectasis		1 (2%)		
Hyperplasia	1 (2%)	1 (2%)		
Integumentary System				
Mammary gland	(50)	(50)	(50)	(50)
Hyperplasia	3 (6%)		4 (8%)	
Skin	(50)	(50)	(50)	(50)
Inflammation, chronic	1 (2%)			
Inflammation, suppurative	1 (2%)	2 (4%)		
Epidermis, hyperplasia		1 (2%)		
Subcutaneous tissue, inflammation, chronic			1 (2%)	
Musculoskeletal System				
Bone	(50)	(50)	(50)	(50)
Fibrous osteodystrophy	28 (56%)	21 (42%)	22 (44%)	32 (64%)
Fracture			3 (6%)	

TABLE D5
Summary of the Incidence of Nonneoplastic Lesions in Female Mice in the 2-Year Inhalation Study of Vanadium Pentoxide

	Chamber Control	1 mg/m ³	2 mg/m ³	4 mg/m ³
Nervous System				
Brain	(50)	(50)	(50)	(50)
Hemorrhage			1 (2%)	
Hydrocephalus	1 (2%)	1 (2%)		
Necrosis	2 (4%)		2 (4%)	
Meninges, infiltration cellular, mononuclear cell		2 (4%)		
Meninges, inflammation		1 (2%)	1 (2%)	
Respiratory System				
Larynx	(50)	(50)	(49)	(50)
Inflammation, suppurative	3 (6%)	2 (4%)	3 (6%)	1 (2%)
Respiratory epithelium, epiglottis, metaplasia, squamous		39 (78%)	45 (92%)	44 (88%)
Squamous epithelium, hyperplasia	15 (30%)	10 (20%)	17 (35%)	14 (28%)
Lung	(50)	(50)	(50)	(50)
Amyloid deposition		1 (2%)		
Hemorrhage	4 (8%)	3 (6%)	4 (8%)	4 (8%)
Infiltration cellular, mast cell		1 (2%)		
Inflammation, chronic	4 (8%)	37 (74%)	39 (78%)	49 (98%)
Inflammation, chronic, focal		1 (2%)		
Metaplasia, osseous	1 (2%)			
Mineralization	1 (2%)			
Thrombosis	1 (2%)			
Alveolar epithelium, hyperplasia		31 (62%)	38 (76%)	50 (100%)
Alveolus, infiltration cellular, histiocyte		34 (68%)	35 (70%)	45 (90%)
Bronchiole, epithelium, hyperplasia		12 (24%)	34 (68%)	48 (96%)
Interstitial, fibrosis		1 (2%)	4 (8%)	8 (16%)
Perivascular, infiltration cellular	2 (4%)	2 (4%)	3 (6%)	
Nose	(50)	(50)	(50)	(50)
Infiltration cellular, lymphocyte				1 (2%)
Inflammation, chronic			2 (4%)	
Inflammation, suppurative	19 (38%)	14 (28%)	32 (64%)	30 (60%)
Lateral wall, hyperplasia			1 (2%)	2 (4%)
Lateral wall, metaplasia, squamous	1 (2%)	1 (2%)	4 (8%)	1 (2%)
Olfactory epithelium, atrophy	2 (4%)	8 (16%)	5 (10%)	14 (28%)
Olfactory epithelium, degeneration, hyaline	11 (22%)	23 (46%)	34 (68%)	48 (96%)
Respiratory epithelium, degeneration, hyaline	35 (70%)	39 (78%)	46 (92%)	50 (100%)
Respiratory epithelium, hyperplasia	1 (2%)		1 (2%)	1 (2%)
Respiratory epithelium, metaplasia, squamous		3 (6%)	7 (14%)	8 (16%)
Respiratory epithelium, necrosis			1 (2%)	7 (14%)
Pleura		(1)		(1)
Mesothelium, hyperplasia		1 (100%)		1 (100%)
Trachea	(50)	(49)	(47)	(50)
Inflammation, suppurative		1 (2%)		
Metaplasia, squamous				1 (2%)
Special Senses System				
Eye			(1)	
Anterior chamber, cornea, inflammation			1 (100%)	
Harderian gland	(3)	(1)	(1)	
Inflammation, focal, granulomatous	1 (33%)			

TABLE D5
Summary of the Incidence of Nonneoplastic Lesions in Female Mice in the 2-Year Inhalation Study of Vanadium Pentoxide

	Chamber Control	1 mg/m ³	2 mg/m ³	4 mg/m ³
Urinary System				
Kidney	(50)	(50)	(49)	(50)
Accumulation, hyaline droplet	2 (4%)	1 (2%)		1 (2%)
Cyst	1 (2%)	1 (2%)		1 (2%)
Glomerulosclerosis	1 (2%)			
Infiltration cellular, mononuclear cell		1 (2%)		
Metaplasia, osseous	3 (6%)	3 (6%)	1 (2%)	2 (4%)
Nephropathy	43 (86%)	33 (66%)	43 (88%)	39 (78%)
Pigmentation, hemosiderin	1 (2%)			
Artery, inflammation	1 (2%)		1 (2%)	
Renal tubule, degeneration, hyaline			1 (2%)	
Renal tubule, pigmentation, hemosiderin	1 (2%)			

APPENDIX E

GENETIC TOXICOLOGY

<i>SALMONELLA TYPHIMURIUM</i> MUTAGENICITY TEST PROTOCOL	264
MOUSE PERIPHERAL BLOOD MICRONUCLEUS TEST PROTOCOL	264
EVALUATION PROTOCOL	265
RESULTS	265
TABLE E1 Mutagenicity of Vanadium Pentoxide in <i>Salmonella typhimurium</i>	266
TABLE E2 Frequency of Micronuclei in Peripheral Blood Normochromatic Erythrocytes of Mice Following Exposure to Vanadium Pentoxide by Inhalation for 3 Months	268

GENETIC TOXICOLOGY

***SALMONELLA TYPHIMURIUM* MUTAGENICITY TEST PROTOCOL**

Testing was performed as reported by Zeiger *et al.* (1992). Vanadium pentoxide was sent to the laboratory as a coded aliquot from Radian Corporation (Austin, TX). It was incubated with the *Salmonella typhimurium* tester strains TA97, TA98, TA100, TA102, and TA1535 either in buffer or S9 mix (metabolic activation enzymes and cofactors from Aroclor 1254-induced male Sprague-Dawley rat or Syrian hamster liver) for 20 minutes at 37° C. Top agar supplemented with L-histidine and d-biotin was added, and the contents of the tubes were mixed and poured onto the surfaces of minimal glucose agar plates. Histidine-independent mutant colonies arising on these plates were counted following incubation for 2 days at 37° C.

Each trial consisted of triplicate plates of concurrent positive and negative controls and five doses of vanadium pentoxide. The high dose was limited by toxicity.

In this assay, a positive response is defined as a reproducible, dose-related increase in histidine-independent (revertant) colonies in any one strain/activation combination. An equivocal response is defined as an increase in revertants that is not dose related, is not reproducible, or is not of sufficient magnitude to support a determination of mutagenicity. A negative response is obtained when no increase in revertant colonies is observed following chemical treatment. There is no minimum percentage or fold increase required for a chemical to be judged positive or weakly positive.

MOUSE PERIPHERAL BLOOD MICRONUCLEUS TEST PROTOCOL

A detailed discussion of this assay is presented by MacGregor *et al.* (1990). At the end of the 3-month study, peripheral blood samples were obtained from male and female mice. Smears were immediately prepared and fixed in absolute methanol. The methanol-fixed slides were stained with acridine orange and coded. Slides were scanned to determine the frequency of micronuclei in 2,000 normochromatic erythrocytes (NCEs) in each of nine or ten animals per exposure group. In addition, the ratio of polychromatic erythrocytes (PCEs) to NCEs among 1,000 total erythrocytes was determined as a measure of bone marrow toxicity.

The results were tabulated as the mean of the pooled results from all animals within a treatment group plus or minus the standard error of the mean. The frequency of micronucleated cells among NCEs was analyzed by a statistical software package that tested for increasing trend over exposure groups with a one-tailed Cochran-Armitage trend test, followed by pairwise comparisons between each exposed group and the control group (ILS, 1990). In the presence of excess binomial variation, as detected by a binomial dispersion test, the binomial variance of the Cochran-Armitage test was adjusted upward in proportion to the excess variation. In the micronucleus test, an individual trial is considered positive if the trend test P value is less than or equal to 0.025 or if the P value for any single exposed group is less than or equal to 0.025 divided by the number of exposed groups. A final call of positive for micronucleus induction is preferably based on reproducibly positive trials (as noted above). Results of the 3-month study were accepted without repeat tests, because additional test data could not be obtained. Ultimately, the final call is determined by the scientific staff after considering the results of statistical analyses, the reproducibility of any effects observed, and the magnitudes of those effects.

EVALUATION PROTOCOL

These are the basic guidelines for arriving at an overall assay result for assays performed by the National Toxicology Program. Statistical as well as biological factors are considered. For an individual assay, the statistical procedure for data analysis has been described in the preceding protocol. There have been instances, however, in which multiple aliquots of a chemical were tested in the same assay, and different results were obtained among aliquots and/or among laboratories. Results from more than one aliquot or from more than one laboratory are not simply combined into an overall result. Rather, all the data are critically evaluated, particularly with regard to pertinent protocol variations, in determining the weight of evidence for an overall conclusion of chemical activity in an assay. In addition to multiple aliquots, the *in vitro* assays have another variable that must be considered in arriving at an overall test result. *In vitro* assays are conducted with and without exogenous metabolic activation. Results obtained in the absence of activation are not combined with results obtained in the presence of activation; each testing condition is evaluated separately. The summary table in the Abstract of this Technical Report presents a result that represents a scientific judgement of the overall evidence for activity of the chemical in an assay.

RESULTS

Vanadium pentoxide (0.03 to 333.00 µg/plate) was not mutagenic in *Salmonella typhimurium* strain TA97, TA98, TA100, TA102, or TA1535 with or without induced rat or hamster liver S9 enzymes (Table E1). No increase in the frequency of micronucleated NCEs was seen in peripheral blood samples from male or female B6C3F₁ mice exposed to vanadium pentoxide for 3 months by inhalation (Table E2). Furthermore, chemical exposure had no effect on the ratio of PCEs to NCEs in peripheral blood (data not presented), indicating no toxicity to the bone marrow by vanadium pentoxide.

TABLE E1
Mutagenicity of Vanadium Pentoxide in *Salmonella typhimurium*^a

Strain	Dose ($\mu\text{g}/\text{plate}$)	Revertants/Plate ^b							
		-S9		+hamster S9			+rat S9		
		Trial 1	Trial 2	10%	30%	30%	10%	30%	30%
TA102	0.00	180 \pm 3.3	161 \pm 4.1	228 \pm 2.2	242 \pm 19.0		267 \pm 10.1	165 \pm 0.3	
	0.03	175 \pm 18.0							
	0.10	174 \pm 7.2	157 \pm 15.7						
	0.30	158 \pm 8.2	134 \pm 9.5	169 \pm 4.6	248 \pm 6.7		196 \pm 4.2	177 \pm 11.2	
	1.00	171 \pm 8.4	111 \pm 2.7	165 \pm 3.2	253 \pm 15.5		187 \pm 6.7	207 \pm 3.4	
	3.00	179 \pm 17.2	101 \pm 9.0	163 \pm 8.2	251 \pm 18.2		151 \pm 0.3	201 \pm 3.5	
	6.00		128 \pm 14.0						
	10.00			155 \pm 1.5	204 \pm 5.5		162 \pm 5.2	189 \pm 7.2	
	33.00			137 \pm 22.8	223 \pm 38.5		190 \pm 14.8	94 \pm 52.9	
	Trial summary		Equivocal	Negative	Negative	Negative	Negative	Negative	Negative
Positive control ^c		813 \pm 13.5	739 \pm 9.7	534 \pm 59.0	926 \pm 74.0		1,077 \pm 26.6	1,236 \pm 18.7	
TA100	0.00	117 \pm 5.2	127 \pm 1.2	135 \pm 3.8	117 \pm 2.6	149 \pm 3.0	110 \pm 7.2	103 \pm 9.6	125 \pm 6.5
	0.10	102 \pm 6.4	108 \pm 9.3						
	0.30	91 \pm 5.5	118 \pm 4.2	152 \pm 13.2			116 \pm 4.7		
	1.00	104 \pm 4.2	104 \pm 7.0	127 \pm 12.0		114 \pm 10.5	110 \pm 3.3		134 \pm 9.7
	3.00	92 \pm 6.1	102 \pm 7.0	119 \pm 3.0	87 \pm 3.8	108 \pm 4.6	106 \pm 8.2	104 \pm 9.6	103 \pm 5.7
	6.00		100 \pm 16.2						
	10.00	49 \pm 23.8		108 \pm 9.8	103 \pm 5.8	91 \pm 7.2	122 \pm 16.5	99 \pm 1.0	92 \pm 4.4
	33.00			109 \pm 20.5	105 \pm 6.3	91 \pm 10.0	124 \pm 5.5	92 \pm 3.1	106 \pm 9.5
	100.00				57 \pm 23.7 ^d	29 \pm 7.9		94 \pm 18.5 ^d	56 \pm 12.3
	333.00				8 \pm 3.2 ^d			17 \pm 3.3 ^d	
Trial summary		Negative	Negative	Negative	Negative	Negative	Negative	Negative	Negative
Positive control		301 \pm 15.2	390 \pm 20.3	764 \pm 17.2	457 \pm 22.2	543 \pm 22.6	441 \pm 9.8	521 \pm 41.2	504 \pm 20.6
TA1535	0.00	13 \pm 0.3	12 \pm 0.9	10 \pm 1.8	13 \pm 3.5		10 \pm 1.2	16 \pm 1.2	
	0.03	11 \pm 0.7							
	0.10	16 \pm 2.0	15 \pm 1.8						
	0.30	16 \pm 3.0	12 \pm 0.9	9 \pm 0.7	8 \pm 1.5		11 \pm 2.8	15 \pm 0.9	
	1.00	12 \pm 0.9	16 \pm 1.2	9 \pm 1.2	9 \pm 0.9		9 \pm 0.9	14 \pm 1.2	
	3.00	13 \pm 3.7	12 \pm 1.7	8 \pm 1.5	10 \pm 2.0		9 \pm 1.2	15 \pm 1.3	
	6.00		10 \pm 1.5						
	10.00			9 \pm 2.6	11 \pm 0.6		10 \pm 2.2	12 \pm 0.3	
	33.00			7 \pm 2.5	10 \pm 1.8		10 \pm 1.8	9 \pm 0.3	
	Trial summary		Negative	Negative	Negative	Negative	Negative	Negative	Negative
Positive control		320 \pm 12.1	383 \pm 11.2	242 \pm 13.4	319 \pm 1.5		162 \pm 9.8	138 \pm 10.3	

TABLE E1
Mutagenicity of Vanadium Pentoxide in *Salmonella typhimurium*

Strain	Dose ($\mu\text{g}/\text{plate}$)	Revertants/Plate							
		-S9		+hamster S9			+rat S9		
		Trial 1	Trial 2	10%	30%	30%	10%	30%	30%
TA97	0.00	157 \pm 8.2	155 \pm 11.7	159 \pm 6.8	173 \pm 6.4		181 \pm 1.5	165 \pm 6.9	
	0.03	154 \pm 6.8							
	0.10	152 \pm 6.4	168 \pm 15.9						
	0.30	148 \pm 6.2	158 \pm 12.3	185 \pm 3.8	186 \pm 6.7		167 \pm 15.9	201 \pm 6.4	
	1.00	163 \pm 3.7	147 \pm 5.8	153 \pm 12.1	149 \pm 12.3		179 \pm 9.6	172 \pm 37.4	
	3.00	161 \pm 12.4	153 \pm 3.8	154 \pm 3.5	207 \pm 2.3		183 \pm 0.9	205 \pm 11.1	
	6.00		154 \pm 3.4						
	10.00			152 \pm 16.5	174 \pm 11.4		187 \pm 5.5	169 \pm 9.6	
	33.00			119 \pm 33.5	156 \pm 27.1		148 \pm 13.6	209 \pm 7.5	
	Trial summary		Negative	Negative	Negative	Negative		Negative	Negative
Positive control		497 \pm 34.3	374 \pm 4.7	541 \pm 23.7	554 \pm 16.8		324 \pm 10.1	343 \pm 13.5	
TA98	0.00	16 \pm 0.3	17 \pm 1.7	26 \pm 1.5	23 \pm 1.8	23 \pm 1.5	28 \pm 2.1	27 \pm 1.2	28 \pm 1.9
	0.03								
	0.10	11 \pm 1.5	16 \pm 1.8						
	0.30	14 \pm 1.7	14 \pm 1.9	25 \pm 0.7			30 \pm 2.0		
	1.00	13 \pm 2.0	16 \pm 3.2	25 \pm 2.0		20 \pm 3.4	21 \pm 1.9		28 \pm 2.8
	3.00	12 \pm 0.3	13 \pm 1.7	20 \pm 1.9	28 \pm 1.5	18 \pm 0.7	23 \pm 2.0	26 \pm 0.3	22 \pm 2.4
	6.00		14 \pm 3.1						
	10.00	8 \pm 3.0		17 \pm 2.2	22 \pm 3.0	16 \pm 1.2	23 \pm 2.5	28 \pm 2.0	20 \pm 0.6
	33.00			16 \pm 1.2	15 \pm 0.6	7 \pm 1.2	23 \pm 4.7	20 \pm 1.7	15 \pm 4.3
	100.00				10 \pm 4.0	4 \pm 1.2		11 \pm 2.3	9 \pm 3.0
	333.00				2 \pm 1.0			5 \pm 1.8	
	Trial summary		Negative	Negative	Negative	Negative	Negative	Negative	Negative
Positive control		409 \pm 35.1	521 \pm 13.1	614 \pm 29.2	328 \pm 4.3	364 \pm 25.7	286 \pm 10.7	105 \pm 6.5	148 \pm 3.5

^a Study was performed at SRI International. The detailed protocol is presented by Zeiger *et al.* (1992). 0 $\mu\text{g}/\text{plate}$ was the solvent control.

^b Revertants are presented as mean \pm standard error from three plates.

^c The positive controls in the absence of metabolic activation were sodium azide (TA100 and TA1535), 9-aminoacridine (TA97),

^d 4-nitro-*o*-phenylenediamine (TA98), and mitomycin-C (TA102). The positive control for metabolic activation with all strains was 2-aminoanthracene. Slight toxicity

TABLE E2
Frequency of Micronuclei in Peripheral Blood Normochromatic Erythrocytes of Mice
Following Exposure to Vanadium Pentoxide by Inhalation for 3 Months^a

Compound	Dose (mg/m ³)	Number of Mice with Erythrocytes Scored	Micronucleated NCEs/1,000 NCEs ^b	P Value ^c
Male				
Air ^d		10	1.00 ± 0.15	
Vanadium Pentoxide	1	10	1.10 ± 0.16	0.3787
	2	10	0.60 ± 0.15	0.9214
	3	10	0.95 ± 0.24	0.5636
	8	10	0.95 ± 0.16	0.5636
	16	9	1.00 ± 0.22	0.5000
			P=0.812 ^e	
Female				
Air		10	0.50 ± 0.11	
Vanadium Pentoxide	1	10	0.45 ± 0.16	0.5907
	2	10	0.70 ± 0.11	0.2070
	3	10	0.40 ± 0.16	0.6814
	8	10	0.35 ± 0.11	0.7666
	16	10	0.40 ± 0.12	0.6814
			P=0.402	

^a Study was performed at SITEK Research Laboratories. The detailed protocol is presented by MacGregor *et al.* (1990).

NCE=normochromatic erythrocyte

^b Mean ± standard error

^c Pairwise comparison with the chamber control; significant at P<0.005 (ILS, 1990)

^d Chamber control

^e Significance of micronucleated NCEs/1,000 NCEs tested by the one-tailed trend test, significant at P<0.025 (ILS, 1990)

APPENDIX F

CARDIOPULMONARY PHYSIOLOGY STUDIES

TABLE F1	Tidal Breathing Measurements in Rats in the 3-Month Inhalation Study of Vanadium Pentoxide	270
TABLE F2	Lung Volumes, Diffusion Capacity, and Pressure-Volume Measurements in Rats in the 3-Month Inhalation Study of Vanadium Pentoxide	271
TABLE F3	Forced Expiration Measurements in Rats in the 3-Month Inhalation Study of Vanadium Pentoxide	272
TABLE F4	Cardiovascular Measurements in Rats in the 3-Month Inhalation Study of Vanadium Pentoxide	273
TABLE F5	Pulmonary Lavage Data for Rats in the 3-Month Inhalation Study of Vanadium Pentoxide	274

TABLE F1
Tidal Breathing Measurements in Rats in the 3-Month Inhalation Study of Vanadium Pentoxide^a

	Chamber Control	4 mg/m ³	8 mg/m ³	16 mg/m ³
Male				
n	7	10	10	5
Respiratory rate (breaths/minute)	102.2 ± 18.7	171.5 ± 42.7**	188.3 ± 47.9**	120.5 ± 24.4 ^b
Tidal volume (mL)	1.73 ± 0.22	1.26 ± 0.17**	1.14 ± 0.18**	1.24 ± 0.15*
Minute volume (mL/minute)	175.3 ± 17.8	211.7 ± 32.9*	215.1 ± 34.0*	140.7 ± 21.5 ^b
Esophageal pressure (cm H ₂ O)	6.09 ± 1.43	8.19 ± 2.43	9.70 ± 1.52**	13.78 ± 1.41**
Inspiratory time (seconds)	0.27 ± 0.05	0.19 ± 0.05**	0.16 ± 0.04**	0.24 ± 0.05 ^b
Expiratory time (seconds)	0.34 ± 0.07	0.18 ± 0.04**	0.19 ± 0.10**	0.28 ± 0.07 ^b
Peak inspiratory flow (mL/second)	-10.98 ± 1.25	-10.53 ± 1.83	-12.27 ± 0.87	-8.54 ± 1.89**
Peak expiratory flow (mL/second)	12.96 ± 1.59	13.67 ± 3.28	15.14 ± 2.00	12.19 ± 1.20
Expiratory resistance (cm H ₂ O/mL/second)	0.12 ± 0.05 ^c	0.17 ± 0.08	0.15 ± 0.08	0.30 ± 0.12**
Dynamic compliance (mL/cm H ₂ O)	0.40 ± 0.14	0.23 ± 0.10**	0.15 ± 0.04**	0.11 ± 0.02**
Female				
n	9	9	9	6
Respiratory rate (breaths/minute)	74.6 ± 11.3	123.2 ± 18.3**	152.2 ± 32.3**	137.0 ± 38.6**
Tidal volume (mL)	1.50 ± 0.14	1.01 ± 0.20**	0.84 ± 0.09**	1.03 ± 0.11**
Minute volume (mL/minute)	111.9 ± 17.9	127.7 ± 23.4	128.8 ± 23.4	141.7 ± 42.0
Esophageal pressure (cm H ₂ O)	5.79 ± 1.14	6.14 ± 0.65 ^d	7.30 ± 1.35*	12.01 ± 3.02**
Inspiratory time (seconds)	0.36 ± 0.03	0.22 ± 0.04**	0.19 ± 0.04**	0.20 ± 0.05**
Expiratory time (seconds)	0.46 ± 0.12	0.28 ± 0.07**	0.23 ± 0.08**	0.27 ± 0.10**
Peak inspiratory flow (mL/second)	-7.91 ± 1.08	-7.91 ± 1.04	-8.36 ± 1.21	-9.35 ± 3.05
Peak expiratory flow (mL/second)	9.06 ± 1.07	9.88 ± 1.32	12.40 ± 1.48**	10.88 ± 3.18
Expiratory resistance (cm H ₂ O/mL/second)	0.10 ± 0.06	0.13 ± 0.05 ^d	0.11 ± 0.03	0.33 ± 0.13**
Dynamic compliance (mL/cm H ₂ O)	0.31 ± 0.07	0.21 ± 0.05** ^d	0.15 ± 0.04**	0.12 ± 0.04**

* Significantly different ($P \leq 0.05$) from the chamber control group by Dunnett's test

** $P \leq 0.01$

^a Data are presented as mean ± standard deviation.

^b n=4

^c n=6

^d n=8

TABLE F2
Lung Volumes, Diffusion Capacity, and Pressure-Volume Measurements in Rats
in the 3-Month Inhalation Study of Vanadium Pentoxide^a

	Chamber Control	4 mg/m ³	8 mg/m ³	16 mg/m ³
Male				
n	8	10	10	5
Total lung capacity (mL)	12.8 ± 0.9	9.8 ± 0.8**	7.1 ± 0.7**	8.3 ± 1.6**
Residual volume (mL)	1.71 ± 0.22	1.69 ± 0.41	1.79 ± 0.55	3.09 ± 0.71**
Diffusing capacity of CO (mL/minute/mm Hg)	0.189 ± 0.012	0.138 ± 0.012**	0.088 ± 0.015**	0.078 ± 0.015**
Vital capacity-gas (mL)	11.1 ± 0.7 ^b	8.1 ± 0.6**	5.3 ± 0.3**	5.2 ± 1.0**
Vital capacity (mL)	10.4 ± 0.6 ^b	7.7 ± 0.3**	4.9 ± 0.4**	5.2 ± 1.0**
Peak compliance (mL/cm H ₂ O)	1.07 ± 0.07 ^b	0.81 ± 0.11**	0.40 ± 0.05**	0.32 ± 0.06**
Compliance at 0 to 10 cm H ₂ O (mL/cm H ₂ O)	0.67 ± 0.04 ^b	0.42 ± 0.05**	0.24 ± 0.01**	0.23 ± 0.04**
End expiratory volume (mL)	4.5 ± 1.0 ^b	5.4 ± 0.4*	4.9 ± 0.5	8.6 ± 1.6**
Female				
n	9	9	10	6
Total lung capacity (mL)	8.9 ± 1.0	7.8 ± 0.5**	5.6 ± 0.6**	8.7 ± 1.0
Residual volume (mL)	1.09 ± 0.08	1.20 ± 0.24	1.05 ± 0.36	3.43 ± 0.69**
Diffusing capacity of CO (mL/minute/mm Hg)	0.115 ± 0.010	0.098 ± 0.010**	0.060 ± 0.004**	0.081 ± 0.021**
Vital capacity-gas (mL)	7.8 ± 1.0	6.6 ± 0.5**	4.6 ± 0.4**	5.3 ± 0.7**
Vital capacity (mL)	7.7 ± 1.1	6.3 ± 0.6**	4.4 ± 0.5** ^c	5.0 ± 0.4** ^d
Peak compliance (mL/cm H ₂ O)	0.80 ± 0.12	0.65 ± 0.06**	0.36 ± 0.04** ^c	0.35 ± 0.04** ^d
Compliance at 0 to 10 cm H ₂ O (mL/cm H ₂ O)	0.51 ± 0.07	0.38 ± 0.03**	0.24 ± 0.02** ^c	0.22 ± 0.04** ^d
End expiratory volume (mL)	4.3 ± 0.8 ^e	3.9 ± 0.5 ^e	4.0 ± 0.5 ^f	8.6 ± 1.2** ^d

* Significantly different (P<0.05) from the chamber control group by Dunnett's test

** P<0.01

^a Data are presented as mean ± standard deviation.

^b n=7

^c n=9

^d n=5

^e n=8

^f n=7

TABLE F3
Forced Expiration Measurements in Rats in the 3-Month Inhalation Study of Vanadium Pentoxide^a

	Chamber Control	4 mg/m ³	8 mg/m ³	16 mg/m ³
Male				
n	7	10	10	5
Forced vital capacity (mL)	10.2 ± 0.6	7.7 ± 0.6**	4.9 ± 0.5**	5.2 ± 1.2**
Volume @ 50 mseconds of expiration (mL)	4.14 ± 0.64	3.43 ± 0.31*	3.06 ± 0.25**	1.87 ± 0.20**
Volume @ 100 mseconds of expiration (mL)	7.38 ± 1.06	6.09 ± 0.54**	4.44 ± 0.48**	2.75 ± 0.30**
Volume @ 200 mseconds of expiration (mL)	9.54 ± 0.67	7.30 ± 0.44**	4.81 ± 0.53**	3.56 ± 0.51**
Volume @ 400 mseconds of expiration (mL)	10.12 ± 0.54	7.64 ± 0.52**	4.93 ± 0.53**	4.40 ± 0.80**
Peak expiratory flow (mL/second)	142.6 ± 13.9	118.2 ± 9.9**	107.9 ± 5.5**	85.7 ± 12.7**
Volume at peak expiratory flow (mL)	2.0 ± 0.5	1.5 ± 0.2*	1.3 ± 0.2**	0.6 ± 0.1**
Mean mid-expiratory flow (mL/second)	76.0 ± 20.2	70.2 ± 13.1	71.6 ± 13.3	13.9 ± 6.1**
Flow @ 75% forced vital capacity (mL/second)	133.6 ± 30.2	114.0 ± 15.0*	105.0 ± 5.7**	54.6 ± 14.2**
Flow @ 50% forced vital capacity (mL/second)	79.1 ± 23.4	78.6 ± 18.7	87.5 ± 19.0	17.5 ± 8.7**
Flow @ 25% forced vital capacity (mL/second)	47.8 ± 12.9	42.1 ± 7.6	38.6 ± 9.5	6.1 ± 2.6**
Flow @ 10% forced vital capacity (mL/second)	19.5 ± 3.8	13.1 ± 5.8*	12.9 ± 4.7*	2.8 ± 0.4**
Female				
n	8	8	8	5
Forced vital capacity (mL)	7.6 ± 1.1	6.3 ± 0.6*	4.3 ± 0.5**	4.8 ± 0.5**
Volume @ 50 mseconds of expiration (mL)	3.43 ± 0.32	2.94 ± 0.43*	2.95 ± 0.24*	1.68 ± 0.24**
Volume @ 100 mseconds of expiration (mL)	5.74 ± 0.42	4.72 ± 0.72**	3.94 ± 0.40**	2.62 ± 0.39**
Volume @ 200 mseconds of expiration (mL)	7.17 ± 0.87	5.72 ± 0.56**	4.18 ± 0.43**	3.49 ± 0.45**
Volume @ 400 mseconds of expiration (mL)	7.60 ± 1.09	6.10 ± 0.40**	4.26 ± 0.45**	4.25 ± 0.46**
Peak expiratory flow (mL/second)	125.7 ± 11.7	113.3 ± 14.2	115.9 ± 8.4	72.5 ± 7.6**
Volume at peak expiratory flow (mL)	1.4 ± 0.3	1.2 ± 0.4	1.3 ± 0.2	0.6 ± 0.1**
Mean mid-expiratory flow (mL/second)	59.2 ± 9.6	50.1 ± 19.6	72.7 ± 13.4	13.5 ± 4.4**
Flow @ 75% forced vital capacity (mL/second)	116.8 ± 16.6	101.0 ± 29.8	111.3 ± 7.0	50.4 ± 13.8**
Flow @ 50% forced vital capacity (mL/second)	62.9 ± 12.8	53.5 ± 21.3	89.6 ± 17.9**	16.7 ± 5.9**
Flow @ 25% forced vital capacity (mL/second)	34.9 ± 5.9	29.7 ± 14.1	37.7 ± 9.8	5.3 ± 1.4**
Flow @ 10% forced vital capacity (mL/second)	14.5 ± 3.4	11.3 ± 3.7	12.5 ± 4.1	3.0 ± 1.5**

* Significantly different (P<0.05) from the chamber control group by Dunnett's test

** P<0.01

^a Data are presented as mean ± standard deviation.

TABLE F4
Cardiovascular Measurements in Rats in the 3-Month Inhalation Study of Vanadium Pentoxide^a

	Chamber Control	4 mg/m ³	8 mg/m ³	16 mg/m ³
Male				
n	8	10	10	5
Systolic blood pressure (mm Hg)	131 ± 19	123 ± 24 ^b	125 ± 17	69 ± 10**
Diastolic blood pressure (mm Hg)	108 ± 21	101 ± 21 ^b	102 ± 16	50 ± 18**
Mean blood pressure (mm Hg)	115 ± 20	108 ± 21 ^b	109 ± 16	56 ± 15**
Heart rate (beats/minute)	433 ± 30	438 ± 36	448 ± 41	374 ± 75
P-wave-to-R-wave interval (msecond)	42 ± 4	42 ± 2	42 ± 4	42 ± 3
QRS interval (msecond)	14 ± 4	15 ± 2	11 ± 2	15 ± 0
Q-to-peak-T interval (msecond)	31 ± 2	30 ± 3	30 ± 2	45 ± 19
Axis shift (degree)	33 ± 15	27 ± 18	38 ± 17	34 ± 30
Female				
n	9	9	10	7
Systolic blood pressure (mm Hg)	120 ± 8	126 ± 7	111 ± 18 ^b	86 ± 16** ^c
Diastolic blood pressure (mm Hg)	102 ± 6	107 ± 11	91 ± 17 ^b	69 ± 19** ^c
Mean blood pressure (mm Hg)	108 ± 6	113 ± 9	97 ± 17 ^b	75 ± 17** ^c
Heart rate (beats/minute)	428 ± 30	433 ± 50	415 ± 20	399 ± 90
P-wave-to-R-wave interval (msecond)	41 ± 2	44 ± 4	42 ± 5	39 ± 2
QRS interval (msecond)	14 ± 3	14 ± 3	14 ± 3	13 ± 4
Q-to-peak-T interval (msecond)	36 ± 6	32 ± 4	32 ± 4	49 ± 9**
Axis shift (degree)	48 ± 17	42 ± 16	33 ± 16	12 ± 32

** Significantly different (P<0.01) from the chamber control group by Dunnett's test

^a Data are presented as mean ± standard deviation.

^b n=9

^c n=5

TABLE F5
Pulmonary Lavage Data for Rats in the 3-Month Inhalation Study of Vanadium Pentoxide^a

	Chamber Control	4 mg/m ³	8 mg/m ³	16 mg/m ³
Male				
n	8	10	10	5
Total cells (10 ⁷)	2.2036 ± 1.2556	2.8281 ± 0.55458	3.0875 ± 0.36069*	1.7083 ± 0.24116
Total viable cells (10 ⁷)	2.1185 ± 1.2309	2.6896 ± 0.52066	2.9633 ± 0.33178*	1.5783 ± 0.24607
Viability (%)	95.54 ± 2.52	95.14 ± 1.62	96.04 ± 1.91	92.24 ± 2.41*
Macrophages (%)	100.00 ± 0.00	99.20 ± 2.20	99.60 ± 0.84	91.20 ± 16.93
Lymphocytes (%)	0.00 ± 0.00	0.10 ± 0.32	0.30 ± 0.67	0.40 ± 0.55
Neutrophils (%)	0.00 ± 0.00	0.70 ± 2.21	0.10 ± 0.32	8.40 ± 17.13
Protein concentration (µg/mL)	150.99 ± 59.82	486.91 ± 141.71*	597.76 ± 167.01*	238.22 ± 80.92
Female				
n	9	9	10	7
Total cells (10 ⁷)	2.4059 ± 2.0423	2.4949 ± 0.24563	2.7104 ± 1.0183	2.2339 ± 0.38889
Total viable cells (10 ⁷)	2.2951 ± 1.9816	2.3259 ± 0.24552	2.5863 ± 0.97013	2.0893 ± 0.37600
Viability (%)	94.55 ± 2.47	93.18 ± 1.52	95.32 ± 1.61	93.46 ± 2.25
Macrophages (%)	99.78 ± 0.44	98.89 ± 2.62	87.20 ± 17.33*	97.29 ± 2.50
Lymphocytes (%)	0.22 ± 0.44	1.00 ± 2.65	1.70 ± 3.02	2.00 ± 2.00
Neutrophils (%)	0.00 ± 0.00	0.11 ± 0.33	11.10 ± 15.51*	0.71 ± 1.50
Protein concentration (µg/mL)	221.30 ± 164.83	367.39 ± 150.80	471.27 ± 171.25* ^b	263.76 ± 81.73

* Significantly different (P ≤ 0.05) from the chamber control group by Dunnett's test

^a Data are presented as mean ± standard deviation.

^b n=9

APPENDIX G

CLINICAL PATHOLOGY RESULTS

TABLE G1	Hematology, Clinical Chemistry, Urinalysis, and Urine Concentrating Ability Data for Rats in the 3-Month Inhalation Study of Vanadium Pentoxide	276
-----------------	--	------------

TABLE G1
Hematology, Clinical Chemistry, Urinalysis, and Urine Concentrating Ability Data for Rats
in the 3-Month Inhalation Study of Vanadium Pentoxide^a

	Chamber Control	1 mg/m ³	2 mg/m ³	4 mg/m ³	8 mg/m ³	16 mg/m ³
Male						
Hematology						
n						
Day 4	10	10	10	10	10	9
Day 23	9	10	8	10	10	10
Week 13	9	9	10	9	10	3
Automated hematocrit (%)						
Day 4	48.3 ± 1.4	48.6 ± 0.8	50.1 ± 1.3	47.7 ± 1.0	46.1 ± 0.7	45.8 ± 0.5
Day 23	49.7 ± 1.0	48.5 ± 0.6	47.9 ± 0.6	46.7 ± 0.5**	46.9 ± 0.7*	46.5 ± 0.9**
Week 13	48.5 ± 0.6	47.7 ± 0.5	47.6 ± 0.6	48.7 ± 0.9	49.9 ± 0.7	71.2 ± 2.8*
Manual hematocrit (%)						
Day 4	50.2 ± 1.3	50.6 ± 0.8	51.3 ± 1.4	49.3 ± 1.1	47.3 ± 0.7*	46.0 ± 0.6**
Day 23	51.7 ± 1.2	51.0 ± 0.6	50.4 ± 0.6	49.0 ± 0.7	50.1 ± 0.6	48.0 ± 0.8**
Week 13	49.3 ± 0.5	48.8 ± 0.4	48.7 ± 0.5	50.1 ± 0.5	50.9 ± 0.7	67.7 ± 1.9**
Hemoglobin (g/dL)						
Day 4	15.5 ± 0.4	15.8 ± 0.3	16.1 ± 0.5	15.4 ± 0.3	14.8 ± 0.2	14.6 ± 0.1*
Day 23	16.3 ± 0.3	16.0 ± 0.1	15.7 ± 0.2	15.3 ± 0.2**	15.5 ± 0.2**	15.0 ± 0.3**
Week 13	15.8 ± 0.1	15.5 ± 0.1	15.5 ± 0.2	15.9 ± 0.2	16.1 ± 0.2	20.4 ± 0.8
Erythrocytes (10 ⁶ /μL)						
Day 4	7.92 ± 0.20	7.93 ± 0.11	8.29 ± 0.22	7.79 ± 0.17	7.51 ± 0.10*	7.54 ± 0.10
Day 23	8.48 ± 0.17	8.31 ± 0.12	8.31 ± 0.12	8.11 ± 0.10	8.28 ± 0.12	8.52 ± 0.17
Week 13	9.17 ± 0.10	9.02 ± 0.09	9.10 ± 0.09	9.32 ± 0.18	9.73 ± 0.12*	15.21 ± 0.28**
Reticulocytes (10 ⁶ /μL)						
Day 4	0.31 ± 0.02	0.35 ± 0.03	0.36 ± 0.04	0.33 ± 0.03 ^b	0.34 ± 0.02	0.35 ± 0.02
Day 23	0.23 ± 0.02	0.20 ± 0.01	0.21 ± 0.02	0.21 ± 0.02	0.21 ± 0.02	0.24 ± 0.01
Week 13	0.20 ± 0.02	0.22 ± 0.03	0.19 ± 0.02	0.23 ± 0.03	0.25 ± 0.02	0.86 ± 0.08*
Nucleated erythrocytes/100 leukocytes						
Day 4	1.90 ± 0.50	0.80 ± 0.25	1.40 ± 0.40	1.30 ± 0.42	0.80 ± 0.25	0.78 ± 0.22
Day 23	0.44 ± 0.18	0.70 ± 0.15	0.13 ± 0.13	0.30 ± 0.21	0.20 ± 0.13	0.90 ± 0.18
Week 13	0.56 ± 0.24	1.22 ± 0.32	0.40 ± 0.16	1.33 ± 0.33	1.40 ± 0.22*	174.67 ± 41.57**
Mean cell volume (fL)						
Day 4	60.9 ± 0.4	61.3 ± 0.5	60.4 ± 0.4	61.3 ± 0.4	61.5 ± 0.4	60.7 ± 0.3
Day 23	58.6 ± 0.2	58.3 ± 0.2	57.7 ± 0.3*	57.5 ± 0.3*	56.7 ± 0.3**	54.6 ± 0.3**
Week 13	52.9 ± 0.2	52.9 ± 0.1	52.3 ± 0.1*	52.2 ± 0.2*	51.3 ± 0.2**	46.8 ± 1.0**
Mean cell hemoglobin (pg)						
Day 4	19.6 ± 0.1	20.0 ± 0.2	19.4 ± 0.2	19.7 ± 0.1	19.7 ± 0.2	19.3 ± 0.1
Day 23	19.3 ± 0.2	19.3 ± 0.1	18.9 ± 0.1	18.9 ± 0.1	18.7 ± 0.1	17.6 ± 0.2**
Week 13	17.3 ± 0.2	17.2 ± 0.1	17.1 ± 0.1	17.1 ± 0.2	16.5 ± 0.2**	13.4 ± 0.4**
Mean cell hemoglobin concentration (g/dL)						
Day 4	32.2 ± 0.2	32.6 ± 0.2	32.1 ± 0.2	32.2 ± 0.1	32.1 ± 0.2	31.8 ± 0.2
Day 23	32.9 ± 0.3	33.0 ± 0.2	32.7 ± 0.1	32.8 ± 0.2	33.0 ± 0.2	32.2 ± 0.2
Week 13	32.6 ± 0.3	32.5 ± 0.2	32.6 ± 0.2	32.7 ± 0.4	32.2 ± 0.3	28.7 ± 0.8*
Platelets (10 ³ /μL)						
Day 4	935.2 ± 17.0	978.9 ± 20.4	955.5 ± 18.5	962.1 ± 12.1	958.4 ± 39.2	1,008.0 ± 12.9*
Day 23	864.6 ± 12.9	861.2 ± 15.7	828.6 ± 14.7	844.0 ± 12.9	868.8 ± 15.1	937.2 ± 13.9**
Week 13	642.7 ± 11.9	634.4 ± 17.2	635.4 ± 15.7	697.0 ± 23.6	733.8 ± 13.4**	572.7 ± 103.4
Leukocytes (10 ³ /μL)						
Day 4	9.27 ± 0.50	9.71 ± 0.52	9.84 ± 0.27	9.40 ± 0.22	9.23 ± 0.40	8.27 ± 0.33
Day 23	9.08 ± 0.46	9.51 ± 0.35	9.53 ± 0.44	9.25 ± 0.33	9.42 ± 0.42	10.54 ± 0.49
Week 13	7.21 ± 0.28	8.61 ± 0.73	7.81 ± 0.36	8.64 ± 0.50	8.31 ± 0.42	3.33 ± 0.27

TABLE G1
Hematology, Clinical Chemistry, Urinalysis, and Urine Concentrating Ability Data for Rats
in the 3-Month Inhalation Study of Vanadium Pentoxide

	Chamber Control	1 mg/m ³	2 mg/m ³	4 mg/m ³	8 mg/m ³	16 mg/m ³
Male (continued)						
Hematology (continued)						
n						
Day 4	10	10	10	10	10	9
Day 23	9	10	8	10	10	10
Week 13	9	9	10	9	10	3
Segmented neutrophils (10 ³ /μL)						
Day 4	1.36 ± 0.16	1.31 ± 0.11	1.37 ± 0.11	1.35 ± 0.11	1.31 ± 0.11	1.27 ± 0.12
Day 23	0.92 ± 0.09	0.93 ± 0.07	1.14 ± 0.06	0.89 ± 0.08	1.02 ± 0.09	1.30 ± 0.13
Week 13	0.80 ± 0.09	1.11 ± 0.15	0.93 ± 0.06	0.97 ± 0.10	1.13 ± 0.13	1.48 ± 0.48
Lymphocytes (10 ³ /μL)						
Day 4	7.53 ± 0.38	7.66 ± 0.41	7.82 ± 0.22	7.42 ± 0.19	7.37 ± 0.34	6.44 ± 0.25
Day 23	7.70 ± 0.37	8.25 ± 0.35	8.04 ± 0.40	8.05 ± 0.34	8.02 ± 0.37	8.60 ± 0.34
Week 13	6.16 ± 0.26	7.20 ± 0.66	6.64 ± 0.36	7.33 ± 0.38	6.91 ± 0.39	1.71 ± 0.34
Monocytes (10 ³ /μL)						
Day 4	0.35 ± 0.05	0.67 ± 0.09*	0.56 ± 0.07	0.56 ± 0.07	0.50 ± 0.06	0.51 ± 0.05
Day 23	0.42 ± 0.07	0.31 ± 0.03	0.30 ± 0.05	0.31 ± 0.03	0.31 ± 0.04	0.51 ± 0.06
Week 13	0.21 ± 0.03	0.27 ± 0.03	0.19 ± 0.02	0.29 ± 0.07	0.21 ± 0.02	0.14 ± 0.05
Eosinophils (10 ³ /μL)						
Day 4	0.02 ± 0.01	0.05 ± 0.02	0.06 ± 0.02	0.06 ± 0.02	0.02 ± 0.01	0.04 ± 0.01
Day 23	0.02 ± 0.01	0.02 ± 0.02	0.04 ± 0.02	0.00 ± 0.00	0.07 ± 0.02*	0.12 ± 0.03**
Week 13	0.04 ± 0.01	0.05 ± 0.02	0.05 ± 0.02	0.05 ± 0.02	0.07 ± 0.02	0.02 ± 0.01
Clinical Chemistry						
n						
Day 4	10	10	10	10	10	10
Day 23	9	10	9	10	10	10
Week 13	10	10	10	10	10	3
Urea nitrogen (mg/dL)						
Day 4	22.3 ± 0.5	21.3 ± 0.4	22.9 ± 0.7	22.3 ± 0.4	22.1 ± 0.6	19.2 ± 0.8*
Day 23	25.2 ± 0.7	23.9 ± 0.4	24.9 ± 0.7	23.2 ± 0.5*	22.3 ± 0.6**	20.4 ± 0.4**
Week 13	22.6 ± 0.4	21.0 ± 0.3*	22.4 ± 0.4	22.4 ± 0.3	22.2 ± 0.4	49.3 ± 19.2
Creatinine (mg/dL)						
Day 4	0.60 ± 0.02	0.57 ± 0.02	0.59 ± 0.02	0.56 ± 0.02	0.61 ± 0.02	0.57 ± 0.02
Day 23	0.65 ± 0.03	0.63 ± 0.03	0.62 ± 0.01	0.60 ± 0.03	0.57 ± 0.02*	0.55 ± 0.01**
Week 13	0.62 ± 0.02	0.63 ± 0.02	0.63 ± 0.02	0.64 ± 0.02	0.62 ± 0.02	0.53 ± 0.05
Total protein (g/dL)						
Day 4	6.1 ± 0.1	6.3 ± 0.1	6.3 ± 0.1	6.2 ± 0.1	6.0 ± 0.1	5.9 ± 0.1
Day 23	6.8 ± 0.1	6.6 ± 0.1	6.5 ± 0.1	6.4 ± 0.1*	6.5 ± 0.0*	6.3 ± 0.1**
Week 13	7.3 ± 0.1	7.1 ± 0.0	7.1 ± 0.1	7.2 ± 0.0	7.1 ± 0.1	6.1 ± 0.3**
Albumin (g/dL)						
Day 4	3.1 ± 0.1	3.2 ± 0.0	3.2 ± 0.1	3.2 ± 0.0	3.0 ± 0.0	2.9 ± 0.0
Day 23	3.5 ± 0.1	3.2 ± 0.0**	3.2 ± 0.0**	3.2 ± 0.1**	3.2 ± 0.0**	3.1 ± 0.1**
Week 13	3.3 ± 0.0	3.3 ± 0.0	3.3 ± 0.0	3.4 ± 0.0	3.3 ± 0.0	2.9 ± 0.2*
Alanine aminotransferase (IU/L)						
Day 4	38 ± 2	40 ± 2	45 ± 2*	48 ± 2**	47 ± 3**	61 ± 2**
Day 23	37 ± 1	39 ± 2	39 ± 1	37 ± 2	46 ± 3*	56 ± 3**
Week 13	129 ± 34	102 ± 13	116 ± 19	86 ± 14	89 ± 12	200 ± 63

TABLE G1
Hematology, Clinical Chemistry, Urinalysis, and Urine Concentrating Ability Data for Rats
in the 3-Month Inhalation Study of Vanadium Pentoxide

	Chamber Control	1 mg/m ³	2 mg/m ³	4 mg/m ³	8 mg/m ³	16 mg/m ³
Male (continued)						
Clinical Chemistry (continued)						
n						
Day 4	10	10	10	10	10	10
Day 23	9	10	9	10	10	10
Week 13	10	10	10	10	10	3
Alkaline phosphatase (IU/L)						
Day 4	871 ± 36	918 ± 43	913 ± 35	885 ± 19	821 ± 25	629 ± 17**
Day 23	683 ± 24	660 ± 23	655 ± 15	596 ± 14**	575 ± 10**	468 ± 13**
Week 13	339 ± 13	317 ± 5	325 ± 4	341 ± 14	320 ± 10	269 ± 8 ^c
Creatine kinase (IU/L)						
Day 4	395 ± 95	286 ± 41	252 ± 26	352 ± 56	280 ± 41	413 ± 68 ^b
Day 23	259 ± 36	206 ± 18	193 ± 40	197 ± 25	193 ± 15	214 ± 16
Week 13	204 ± 68	133 ± 13	154 ± 43	141 ± 25	162 ± 28	309 ± 78
Sorbitol dehydrogenase (IU/L)						
Day 4	16 ± 0	16 ± 0	17 ± 1	17 ± 0	18 ± 1	15 ± 0
Day 23	18 ± 1	19 ± 1	18 ± 1	16 ± 1	17 ± 1	14 ± 1**
Week 13	96 ± 34	71 ± 14	68 ± 15	47 ± 9	49 ± 9	27 ± 8
Bile acids (μmol/L)						
Day 4	17.3 ± 1.1	15.3 ± 0.6	16.4 ± 1.6	16.9 ± 1.5	15.0 ± 1.3	14.4 ± 1.0
Day 23	7.9 ± 0.6	10.7 ± 0.9**	11.6 ± 0.7**	11.4 ± 1.1**	12.8 ± 0.9**	19.1 ± 4.3**
Week 13	21.9 ± 5.1	15.1 ± 1.3	15.0 ± 1.4	18.6 ± 2.4	14.5 ± 1.0	38.9 ± 9.3
Urinalysis						
n						
Week 13	10	0 ^d	10	10	10	0 ^d
Volume (mL/16 hr)						
Week 13	6.8 ± 1.2		7.3 ± 1.1	4.2 ± 0.3	2.2 ± 0.3**	
Specific gravity						
Week 13	1.043 ± 0.006		1.037 ± 0.005	1.045 ± 0.003	1.082 ± 0.012**	
Urine Concentrating Ability						
n						
Week 13	10	0 ^d	10	10	10	0 ^d
Volume (mL/4 hr)						
Week 13	0.6 ± 0.1		0.4 ± 0.1	0.3 ± 0.1	0.5 ± 0.2	
Specific gravity						
Week 13	1.085 ± 0.004 ^b		1.084 ± 0.003 ^b	1.103 ± 0.011 ^e	1.083 ± 0.004 ^b	

TABLE G1
Hematology, Clinical Chemistry, Urinalysis, and Urine Concentrating Ability Data for Rats
in the 3-Month Inhalation Study of Vanadium Pentoxide

	Chamber Control	1 mg/m ³	2 mg/m ³	4 mg/m ³	8 mg/m ³	16 mg/m ³
Female						
Hematology						
n						
Day 4	10	8	10	10	10	10
Day 23	9	10	9	9	10	10
Week 13	10	10	9	10	10	6
Automated hematocrit (%)						
Day 4	48.6 ± 1.3	48.9 ± 1.0	45.0 ± 0.6	46.8 ± 1.7	44.6 ± 0.5*	45.5 ± 0.7
Day 23	47.3 ± 0.4	47.9 ± 0.4	47.6 ± 0.5	47.3 ± 0.4	47.1 ± 0.4	46.9 ± 0.6
Week 13	45.8 ± 0.5	44.3 ± 0.4	46.1 ± 1.2	46.4 ± 0.4	47.2 ± 0.6	60.8 ± 1.4**
Manual hematocrit (%)						
Day 4	50.4 ± 1.2	50.9 ± 0.8	46.2 ± 0.7**	48.1 ± 1.2*	46.0 ± 0.4**	46.0 ± 0.5**
Day 23	48.4 ± 0.5	48.5 ± 0.4	48.9 ± 0.4	48.8 ± 0.5	48.5 ± 0.5	48.4 ± 0.4
Week 13	47.8 ± 0.5	46.6 ± 0.4	48.7 ± 0.6	48.4 ± 0.2	49.4 ± 0.7	58.8 ± 1.3**
Hemoglobin (g/dL)						
Day 4	16.0 ± 0.3	16.3 ± 0.3	14.9 ± 0.2**	15.3 ± 0.5*	14.8 ± 0.2**	14.8 ± 0.2**
Day 23	15.8 ± 0.1	15.9 ± 0.1	15.8 ± 0.1	15.5 ± 0.2	15.5 ± 0.1*	15.1 ± 0.2**
Week 13	15.5 ± 0.2	15.0 ± 0.1	15.5 ± 0.2	15.6 ± 0.1	15.8 ± 0.1	18.2 ± 0.3**
Erythrocytes (10 ⁶ /μL)						
Day 4	8.05 ± 0.21	8.02 ± 0.16	7.43 ± 0.12	7.68 ± 0.28	7.38 ± 0.10	7.54 ± 0.15
Day 23	7.94 ± 0.06	8.00 ± 0.07	8.04 ± 0.09	7.96 ± 0.10	8.13 ± 0.09	8.51 ± 0.14**
Week 13	8.05 ± 0.08	7.78 ± 0.09	8.15 ± 0.20	8.33 ± 0.07	8.58 ± 0.12*	12.50 ± 0.36**
Reticulocytes (10 ⁶ /μL)						
Day 4	0.24 ± 0.03	0.26 ± 0.02	0.20 ± 0.01	0.27 ± 0.04	0.20 ± 0.01	0.26 ± 0.02
Day 23	0.14 ± 0.01	0.15 ± 0.01	0.14 ± 0.01	0.16 ± 0.01	0.19 ± 0.01	0.17 ± 0.02
Week 13	0.15 ± 0.02	0.17 ± 0.01	0.17 ± 0.01	0.16 ± 0.02	0.17 ± 0.02	0.45 ± 0.08**
Nucleated erythrocytes/100 leukocytes						
Day 4	0.90 ± 0.28	1.13 ± 0.44	1.80 ± 0.49	1.70 ± 0.56	0.60 ± 0.31	1.10 ± 0.35
Day 23	0.44 ± 0.34	0.40 ± 0.22 ^b	0.33 ± 0.17	0.33 ± 0.17	0.50 ± 0.17	0.40 ± 0.16
Week 13	1.70 ± 0.42	1.67 ± 0.33 ^b	1.56 ± 0.63	1.30 ± 0.30	1.10 ± 0.41	58.50 ± 26.41**
Mean cell volume (fL)						
Day 4	60.3 ± 0.2	60.9 ± 0.2	60.6 ± 0.2	61.0 ± 0.3	60.5 ± 0.4	60.4 ± 0.3
Day 23	59.6 ± 0.2	60.0 ± 0.2	59.2 ± 0.2	59.4 ± 0.3	57.9 ± 0.3**	55.2 ± 0.3**
Week 13	56.9 ± 0.1	56.9 ± 0.1	56.6 ± 0.1	55.8 ± 0.1**	55.0 ± 0.2**	48.7 ± 0.6**
Mean cell hemoglobin (pg)						
Day 4	19.9 ± 0.2	20.3 ± 0.1	20.1 ± 0.3	19.9 ± 0.1	20.1 ± 0.1	19.7 ± 0.2
Day 23	19.9 ± 0.1	19.9 ± 0.1	19.7 ± 0.2	19.5 ± 0.1*	19.1 ± 0.1**	17.8 ± 0.2**
Week 13	19.3 ± 0.2	19.3 ± 0.2	19.0 ± 0.2	18.7 ± 0.2*	18.5 ± 0.2**	14.6 ± 0.3**
Mean cell hemoglobin concentration (g/dL)						
Day 4	33.0 ± 0.3	33.4 ± 0.2	33.1 ± 0.4	32.6 ± 0.3	33.3 ± 0.3	32.6 ± 0.3
Day 23	33.4 ± 0.3	33.2 ± 0.2	33.2 ± 0.2	32.9 ± 0.1	33.0 ± 0.1	32.3 ± 0.3**
Week 13	33.9 ± 0.4	33.9 ± 0.3	33.6 ± 0.4	33.6 ± 0.3	33.6 ± 0.4	30.1 ± 0.3**
Platelets (10 ³ /μL)						
Day 4	1,048.3 ± 22.8	1,022.4 ± 18.3	1,132.9 ± 88.2	1,041.7 ± 27.7	1,040.1 ± 21.2	1,095.0 ± 22.5
Day 23	766.4 ± 18.1	770.0 ± 7.1	788.6 ± 32.7	810.2 ± 7.8*	813.4 ± 19.8	902.8 ± 19.8**
Week 13	662.7 ± 20.5	710.5 ± 34.5	672.6 ± 17.1	686.0 ± 12.1	716.2 ± 22.1	754.0 ± 29.8*
Leukocytes (10 ³ /μL)						
Day 4	7.90 ± 0.31	8.18 ± 0.23	10.25 ± 0.50**	9.56 ± 0.58**	9.92 ± 0.71**	9.55 ± 0.47**
Day 23	8.70 ± 0.31	8.88 ± 0.31 ^b	9.92 ± 0.29*	9.10 ± 0.38	9.51 ± 0.31	11.36 ± 0.28**
Week 13	8.49 ± 0.46	7.40 ± 0.66 ^b	6.56 ± 0.21*	7.23 ± 0.31	7.17 ± 0.38	6.37 ± 0.55*

TABLE G1
Hematology, Clinical Chemistry, Urinalysis, and Urine Concentrating Ability Data for Rats
in the 3-Month Inhalation Study of Vanadium Pentoxide

	Chamber Control	1 mg/m ³	2 mg/m ³	4 mg/m ³	8 mg/m ³	16 mg/m ³
Female (continued)						
Hematology (continued)						
n						
Day 4	10	8	10	10	10	10
Day 23	9	10	9	9	10	10
Week 13	10	10	9	10	10	6
Segmented neutrophils (10 ³ /μL)						
Day 4	0.99 ± 0.06	0.82 ± 0.10	1.27 ± 0.09	1.44 ± 0.14*	1.57 ± 0.18*	1.44 ± 0.11**
Day 23	1.15 ± 0.12	1.35 ± 0.12	1.32 ± 0.10	1.32 ± 0.09	1.18 ± 0.07	1.83 ± 0.12**
Week 13	0.85 ± 0.09	0.99 ± 0.15 ^b	0.72 ± 0.12	1.09 ± 0.16	0.79 ± 0.11	1.60 ± 0.27
Lymphocytes (10 ³ /μL)						
Day 4	6.62 ± 0.30	7.07 ± 0.25	8.55 ± 0.46*	7.75 ± 0.47	7.91 ± 0.52	7.70 ± 0.44
Day 23	7.15 ± 0.24	7.13 ± 0.27	8.02 ± 0.29	7.37 ± 0.38	7.90 ± 0.32	8.89 ± 0.29**
Week 13	7.40 ± 0.45	6.11 ± 0.49* ^b	5.64 ± 0.21*	5.86 ± 0.22*	6.15 ± 0.42*	4.55 ± 0.48**
Monocytes (10 ³ /μL)						
Day 4	0.27 ± 0.04	0.27 ± 0.04	0.39 ± 0.08	0.30 ± 0.04	0.34 ± 0.05	0.35 ± 0.04
Day 23	0.35 ± 0.04	0.33 ± 0.04	0.52 ± 0.06	0.35 ± 0.05	0.36 ± 0.04	0.56 ± 0.08
Week 13	0.20 ± 0.03	0.25 ± 0.07 ^b	0.15 ± 0.03	0.24 ± 0.04	0.21 ± 0.04	0.20 ± 0.05
Eosinophils (10 ³ /μL)						
Day 4	0.02 ± 0.01	0.01 ± 0.01	0.03 ± 0.02	0.06 ± 0.02	0.08 ± 0.02	0.05 ± 0.02
Day 23	0.04 ± 0.02	0.05 ± 0.02 ^b	0.05 ± 0.03	0.05 ± 0.02	0.05 ± 0.02	0.08 ± 0.02
Week 13	0.04 ± 0.02	0.05 ± 0.01 ^b	0.05 ± 0.01	0.05 ± 0.02	0.02 ± 0.01	0.03 ± 0.02
Clinical Chemistry						
n						
Day 4	10	10	10	10	10	10
Day 23	9	10	10	9	10	10
Week 13	10	10	10	10	10	7
Urea nitrogen (mg/dL)						
Day 4	22.8 ± 0.7	24.6 ± 1.0	22.8 ± 0.8	23.1 ± 0.7	24.7 ± 0.5	19.6 ± 0.8
Day 23	26.0 ± 0.4	27.1 ± 0.8	26.6 ± 0.7	25.4 ± 0.5	24.9 ± 0.6	22.8 ± 0.9*
Week 13	21.9 ± 0.7	22.7 ± 0.4	22.3 ± 0.5	21.9 ± 0.5	20.8 ± 0.5	33.7 ± 3.8** ^f
Creatinine (mg/dL)						
Day 4	0.59 ± 0.02	0.61 ± 0.02	0.58 ± 0.01	0.57 ± 0.02	0.59 ± 0.03	0.55 ± 0.02
Day 23	0.61 ± 0.02	0.64 ± 0.02	0.62 ± 0.02	0.63 ± 0.01	0.59 ± 0.02	0.57 ± 0.03
Week 13	0.60 ± 0.01	0.64 ± 0.01	0.62 ± 0.02	0.62 ± 0.03	0.57 ± 0.01	0.54 ± 0.02* ^f
Total protein (g/dL)						
Day 4	6.3 ± 0.1	6.2 ± 0.1	6.1 ± 0.1	5.9 ± 0.1**	5.8 ± 0.0**	5.7 ± 0.1**
Day 23	6.3 ± 0.0	6.4 ± 0.1	6.4 ± 0.1	6.4 ± 0.1	6.2 ± 0.1	6.0 ± 0.1*
Week 13	7.1 ± 0.1	7.5 ± 0.1	7.4 ± 0.1	7.0 ± 0.1	6.8 ± 0.1	6.3 ± 0.1**
Albumin (g/dL)						
Day 4	3.0 ± 0.0	3.0 ± 0.1	3.0 ± 0.0	2.8 ± 0.0**	2.8 ± 0.0**	2.8 ± 0.0**
Day 23	3.2 ± 0.0	3.2 ± 0.1	3.2 ± 0.0	3.2 ± 0.0	3.2 ± 0.0	3.0 ± 0.0*
Week 13	3.3 ± 0.0	3.6 ± 0.1*	3.5 ± 0.1	3.4 ± 0.1	3.3 ± 0.1	3.1 ± 0.0
Alanine aminotransferase (IU/L)						
Day 4	35 ± 1	36 ± 2	37 ± 2	42 ± 3*	60 ± 3**	63 ± 4**
Day 23	31 ± 1	29 ± 1	34 ± 2 ^b	36 ± 2 ^b	48 ± 3**	69 ± 3**
Week 13	48 ± 4 ^b	51 ± 6	48 ± 4 ^b	59 ± 4 ^b	81 ± 5**	95 ± 7**

TABLE G1
Hematology, Clinical Chemistry, Urinalysis, and Urine Concentrating Ability Data for Rats
in the 3-Month Inhalation Study of Vanadium Pentoxide

	Chamber Control	1 mg/m ³	2 mg/m ³	4 mg/m ³	8 mg/m ³	16 mg/m ³
Female (continued)						
Clinical Chemistry (continued)						
n						
Day 4	10	10	10	10	10	10
Day 23	9	10	10	9	10	10
Week 13	10	10	10	10	10	7
Alkaline phosphatase (IU/L)						
Day 4	731 ± 19	728 ± 23	725 ± 19	661 ± 27	631 ± 17**	488 ± 28**
Day 23	503 ± 8	481 ± 10	509 ± 12	484 ± 11	474 ± 9*	402 ± 14**
Week 13	319 ± 7	299 ± 10	288 ± 14	298 ± 11	274 ± 12**	171 ± 2** ^g
Creatine kinase (IU/L)						
Day 4	336 ± 57	298 ± 78 ^b	195 ± 25 ^b	186 ± 29*	236 ± 61	273 ± 28
Day 23	207 ± 22	260 ± 50	397 ± 149	151 ± 14	198 ± 27	299 ± 48
Week 13	157 ± 21	131 ± 38	124 ± 19	184 ± 37	174 ± 17	283 ± 36*
Sorbitol dehydrogenase (IU/L)						
Day 4	16 ± 1	17 ± 1	16 ± 1	16 ± 1	17 ± 2	16 ± 1
Day 23	28 ± 2	25 ± 1	22 ± 1	24 ± 1	23 ± 1	22 ± 1*
Week 13	29 ± 3 ^b	25 ± 3 ^b	25 ± 3 ^b	29 ± 3 ^b	36 ± 7	18 ± 1 ^f
Bile acids (μmol/L)						
Day 4	16.7 ± 1.8	16.1 ± 1.4	12.6 ± 0.8	13.8 ± 1.1	11.5 ± 0.8**	12.3 ± 0.7*
Day 23	13.9 ± 0.8	12.7 ± 0.8	12.6 ± 1.6 ^b	11.6 ± 1.1	12.3 ± 2.4	12.4 ± 0.6
Week 13	18.0 ± 2.6	15.1 ± 1.5	15.1 ± 0.9 ^b	17.1 ± 1.8	14.5 ± 0.9	20.1 ± 2.3

TABLE G1
Hematology, Clinical Chemistry, Urinalysis, and Urine Concentrating Ability Data for Rats
in the 3-Month Inhalation Study of Vanadium Pentoxide

	Chamber Control	1 mg/m ³	2 mg/m ³	4 mg/m ³	8 mg/m ³	16 mg/m ³
Female (continued)						
Urinalysis						
n						
Week 12	10	0 ^d	0 ^d	10	10	8
Volume (mL/16 hr)						
Week 12	7.8 ± 1.1			4.1 ± 0.5* ^b	4.0 ± 0.9* ^b	1.5 ± 0.5** ^b
Specific gravity						
Week 12	1.027 ± 0.006			1.034 ± 0.004	1.037 ± 0.008	1.099 ± 0.024**
Urine Concentrating Ability						
n						
Week 12	10	0 ^d	0 ^d	9	7	8
Volume (mL/4 hr)						
Week 12	0.2 ± 0.1			0.2 ± 0.1	0.3 ± 0.1 ^e	0.2 ± 0.1
Specific gravity						
Week 12	1.093 ± 0.020 ^e			1.082 ± 0.003 ^h	1.066 ± 0.005	1.081 ± 0.006 ^h

* Significantly different ($P \leq 0.05$) from the chamber control group by Dunn's or Shirley's test

** $P \leq 0.01$

^a Mean ± standard error. Statistical tests were performed on unrounded data.

^b n=9

^c n=2

^d Not measured for this exposure group

^e n=8

^f n=6

^g n=5

^h n=4

APPENDIX H

ORGAN WEIGHTS AND ORGAN-WEIGHT-TO-BODY-WEIGHT RATIOS

TABLE H1	Organ Weights and Organ-Weight-to-Body-Weight Ratios for Rats in the 16-Day Inhalation Study of Vanadium Pentoxide	284
TABLE H2	Organ Weights and Organ-Weight-to-Body-Weight Ratios for Rats in the 3-Month Inhalation Study of Vanadium Pentoxide	285
TABLE H3	Organ Weights and Organ-Weight-to-Body-Weight Ratios for Mice in the 16-Day Inhalation Study of Vanadium Pentoxide	286
TABLE H4	Organ Weights and Organ-Weight-to-Body-Weight Ratios for Mice in the 3-Month Inhalation Study of Vanadium Pentoxide	287

TABLE H1
Organ Weights and Organ-Weight-to-Body-Weight Ratios for Rats in the 16-Day Inhalation Study of Vanadium Pentoxide^a

	Chamber Control	2 mg/m ³	4 mg/m ³	8 mg/m ³	16 mg/m ³	32 mg/m ³
Male						
n	5	5	5	5	5	2
Necropsy body wt	212 ± 7	211 ± 6	209 ± 7	194 ± 6	184 ± 7**	128 ± 15**
Heart						
Absolute	0.740 ± 0.028	0.788 ± 0.017	0.774 ± 0.042	0.722 ± 0.034	0.736 ± 0.032	0.535 ± 0.085*
Relative	3.490 ± 0.032	3.746 ± 0.101	3.702 ± 0.187	3.712 ± 0.084	4.000 ± 0.137**	4.156 ± 0.167**
R. Kidney						
Absolute	0.954 ± 0.037	0.956 ± 0.027	0.980 ± 0.024	0.878 ± 0.053	0.882 ± 0.028	0.695 ± 0.105**
Relative	4.499 ± 0.064	4.539 ± 0.103	4.691 ± 0.090	4.505 ± 0.138	4.800 ± 0.142	5.405 ± 0.174**
Liver						
Absolute	10.640 ± 0.492	11.380 ± 0.242	11.900 ± 0.620	10.900 ± 0.391	10.440 ± 0.495	6.900 ± 0.600**
Relative	50.133 ± 1.080	54.032 ± 0.562	56.735 ± 1.220**	56.206 ± 1.892**	56.633 ± 1.021**	54.076 ± 1.775
Lung						
Absolute	1.552 ± 0.203	1.710 ± 0.113	1.912 ± 0.111	1.890 ± 0.077	2.090 ± 0.168*	1.490 ± 0.110
Relative	7.310 ± 0.929	8.098 ± 0.414	9.133 ± 0.382*	9.735 ± 0.307**	11.303 ± 0.605**	11.696 ± 0.538**
R. Testis						
Absolute	1.137 ± 0.026	1.241 ± 0.049	1.187 ± 0.038	1.106 ± 0.024	1.119 ± 0.016	0.924 ± 0.215*
Relative	5.374 ± 0.123	5.914 ± 0.340	5.680 ± 0.161	5.705 ± 0.132	6.101 ± 0.188*	7.114 ± 0.829**
Thymus						
Absolute	0.545 ± 0.016	0.573 ± 0.020	0.606 ± 0.045	0.518 ± 0.035	0.531 ± 0.032	0.223 ± 0.148**
Relative	2.575 ± 0.068	2.725 ± 0.120	2.912 ± 0.246	2.672 ± 0.179	2.886 ± 0.161	1.626 ± 0.961
Female						
n	5	5	5	5	5	5
Necropsy body wt	142 ± 2	141 ± 3	137 ± 1	131 ± 3*	125 ± 5**	106 ± 5**
Heart						
Absolute	0.550 ± 0.018	0.526 ± 0.012	0.556 ± 0.028	0.540 ± 0.015	0.542 ± 0.041	0.508 ± 0.017
Relative	3.880 ± 0.123	3.722 ± 0.071	4.057 ± 0.179	4.127 ± 0.079	4.315 ± 0.266	4.848 ± 0.347**
R. Kidney						
Absolute	0.676 ± 0.012	0.638 ± 0.027	0.670 ± 0.026	0.594 ± 0.017	0.644 ± 0.045	0.588 ± 0.017*
Relative	4.768 ± 0.039	4.507 ± 0.120	4.888 ± 0.148	4.546 ± 0.147	5.122 ± 0.237	5.579 ± 0.225**
Liver						
Absolute	6.498 ± 0.181	6.456 ± 0.205	6.726 ± 0.246	6.384 ± 0.283	6.530 ± 0.371	6.152 ± 0.351
Relative	45.796 ± 0.599	45.626 ± 0.718	49.105 ± 1.623	48.799 ± 1.949	52.021 ± 2.097*	58.188 ± 2.937**
Lung						
Absolute	1.094 ± 0.074	1.512 ± 0.080**	1.344 ± 0.102	1.338 ± 0.049	1.440 ± 0.072*	1.396 ± 0.067*
Relative	7.728 ± 0.566	10.706 ± 0.574**	9.803 ± 0.692**	10.231 ± 0.350**	11.499 ± 0.493**	13.165 ± 0.178**
Thymus						
Absolute	0.407 ± 0.020	0.404 ± 0.031	0.397 ± 0.017	0.430 ± 0.013	0.346 ± 0.007	0.272 ± 0.040**
Relative	2.868 ± 0.134	2.862 ± 0.220	2.899 ± 0.137	3.288 ± 0.102	2.778 ± 0.144	2.526 ± 0.311

* Significantly different ($P \leq 0.05$) from the chamber control group by Williams' or Dunnett's test

** $P \leq 0.01$

^a Organ weights (absolute weights) and body weights are given in grams; organ-weight-to-body-weight ratios (relative weights) are given as mg organ weight/g body weight (mean ± standard error).

TABLE H2
Organ Weights and Organ-Weight-to-Body-Weight Ratios for Rats in the 3-Month Inhalation Study of Vanadium Pentoxide^a

	Chamber Control	1 mg/m ³	2 mg/m ³	4 mg/m ³	8 mg/m ³	16 mg/m ³
Male						
n	10	10	10	10	10	3
Necropsy body wt	350 ± 8	345 ± 5	339 ± 6	334 ± 7	319 ± 7**	119 ± 4**
Heart						
Absolute	1.005 ± 0.025	1.015 ± 0.016	1.042 ± 0.035	1.039 ± 0.026	1.014 ± 0.032	0.703 ± 0.038**
Relative	2.876 ± 0.043	2.947 ± 0.048	3.073 ± 0.079	3.112 ± 0.074*	3.173 ± 0.059**	5.903 ± 0.365**
R. Kidney						
Absolute	1.212 ± 0.035	1.197 ± 0.026	1.232 ± 0.029	1.209 ± 0.029	1.175 ± 0.029	0.640 ± 0.026**
Relative	3.465 ± 0.035	3.472 ± 0.056	3.638 ± 0.063*	3.619 ± 0.066*	3.681 ± 0.047**	5.360 ± 0.097**
Liver						
Absolute	12.298 ± 0.440	12.849 ± 0.226	12.757 ± 0.460	12.783 ± 0.384	12.102 ± 0.417	4.860 ± 0.391**
Relative	35.145 ± 0.782	37.271 ± 0.440	37.622 ± 1.044	38.221 ± 0.781	37.887 ± 0.962	40.594 ± 1.936**
Lung						
Absolute	2.378 ± 0.168	2.553 ± 0.108	2.650 ± 0.072	2.934 ± 0.088**	3.258 ± 0.127**	1.983 ± 0.103*
Relative	6.769 ± 0.363	7.400 ± 0.278	7.828 ± 0.189**	8.780 ± 0.216**	10.200 ± 0.299**	16.595 ± 0.333**
R. Testis						
Absolute	1.414 ± 0.020	1.402 ± 0.012	1.420 ± 0.036	1.468 ± 0.027	1.422 ± 0.034	0.429 ± 0.064**
Relative	4.057 ± 0.085	4.072 ± 0.064	4.197 ± 0.113	4.399 ± 0.080	4.463 ± 0.100	3.608 ± 0.580
Thymus						
Absolute	0.348 ± 0.013	0.381 ± 0.015	0.426 ± 0.025**	0.364 ± 0.016	0.362 ± 0.013	0.051 ± 0.007**
Relative	0.996 ± 0.035	1.105 ± 0.044	1.253 ± 0.062**	1.086 ± 0.038	1.132 ± 0.028	0.429 ± 0.051**
Female						
n	10	10	10	10	10	7
Necropsy body wt	198 ± 3	202 ± 5	208 ± 5	196 ± 4	189 ± 5	120 ± 5**
Heart						
Absolute	0.662 ± 0.021	0.701 ± 0.019	0.738 ± 0.025	0.718 ± 0.026	0.731 ± 0.028	0.694 ± 0.036
Relative	3.352 ± 0.105	3.476 ± 0.073	3.562 ± 0.106	3.655 ± 0.103	3.863 ± 0.084**	5.813 ± 0.209**
R. Kidney						
Absolute	0.712 ± 0.012	0.722 ± 0.011	0.735 ± 0.022	0.748 ± 0.016	0.740 ± 0.020	0.646 ± 0.016*
Relative	3.604 ± 0.051	3.588 ± 0.070	3.539 ± 0.056	3.814 ± 0.056*	3.923 ± 0.078**	5.424 ± 0.133**
Liver						
Absolute	6.676 ± 0.188	7.354 ± 0.242	7.348 ± 0.228	7.566 ± 0.218*	7.083 ± 0.222	5.034 ± 0.274**
Relative	33.796 ± 0.934	36.404 ± 0.725*	35.383 ± 0.576*	38.509 ± 0.492**	37.487 ± 0.718**	41.965 ± 0.802**
Lung						
Absolute	1.648 ± 0.108 ^b	1.581 ± 0.039	1.919 ± 0.123*	1.954 ± 0.077* ^b	2.161 ± 0.059**	2.159 ± 0.117**
Relative	8.369 ± 0.578 ^b	7.842 ± 0.155	9.230 ± 0.527	9.996 ± 0.382* ^b	11.475 ± 0.328**	18.154 ± 1.061**
Thymus						
Absolute	0.272 ± 0.015	0.298 ± 0.012	0.288 ± 0.010	0.282 ± 0.021	0.257 ± 0.013	0.085 ± 0.012**
Relative	1.379 ± 0.080	1.478 ± 0.049	1.390 ± 0.034	1.435 ± 0.099	1.362 ± 0.059	0.695 ± 0.080**

* Significantly different ($P \leq 0.05$) from the chamber control group by Williams' or Dunnett's test

** $P \leq 0.01$

^a Organ weights (absolute weights) and body weights are given in grams; organ-weight-to-body-weight ratios (relative weights) are given as mg organ weight/g body weight (mean ± standard error).

^b n=9

TABLE H3
Organ Weights and Organ-Weight-to-Body-Weight Ratios for Mice in the 16-Day Inhalation Study of Vanadium Pentoxide^a

	Chamber Control	2 mg/m ³	4 mg/m ³	8 mg/m ³	16 mg/m ³	32 mg/m ³
Male						
n	5	5	5	4	5	0 ^b
Necropsy body wt	28.0 ± 0.5	27.7 ± 0.4	27.3 ± 0.5	26.7 ± 0.7	26.1 ± 0.6*	
Heart						
Absolute	0.149 ± 0.005	0.144 ± 0.003	0.156 ± 0.009	0.151 ± 0.017	0.162 ± 0.021	
Relative	5.314 ± 0.181	5.181 ± 0.077	5.699 ± 0.282	5.693 ± 0.743	6.193 ± 0.767	
R. Kidney						
Absolute	0.294 ± 0.013	0.295 ± 0.005	0.284 ± 0.010	0.279 ± 0.015	0.268 ± 0.009	
Relative	10.492 ± 0.349	10.639 ± 0.172	10.425 ± 0.373	10.487 ± 0.597	10.281 ± 0.363	
Liver						
Absolute	1.558 ± 0.049	1.538 ± 0.035	1.692 ± 0.052	1.657 ± 0.020	1.704 ± 0.047*	
Relative	55.569 ± 1.041	55.457 ± 0.689	62.029 ± 1.890**	62.253 ± 1.404**	65.319 ± 1.087**	
Lung						
Absolute	0.200 ± 0.011	0.224 ± 0.008	0.275 ± 0.008**	0.295 ± 0.014**	0.324 ± 0.014**	
Relative	7.140 ± 0.374	8.104 ± 0.365	10.076 ± 0.239**	11.058 ± 0.503**	12.430 ± 0.397**	
R. Testis						
Absolute	0.109 ± 0.001	0.107 ± 0.001	0.108 ± 0.003	0.102 ± 0.001*	0.099 ± 0.002**	
Relative	3.881 ± 0.088	3.856 ± 0.066	3.944 ± 0.101	3.815 ± 0.104	3.800 ± 0.095	
Thymus						
Absolute	0.054 ± 0.005	0.055 ± 0.007	0.052 ± 0.006	0.059 ± 0.010	0.055 ± 0.006	
Relative	1.940 ± 0.157	1.995 ± 0.260	1.910 ± 0.195	2.170 ± 0.335	2.118 ± 0.259	
Female						
n	5	5	5	5	5	5
Necropsy body wt	22.9 ± 0.2	22.2 ± 0.1	21.9 ± 0.3	20.7 ± 0.4**	20.8 ± 0.4**	16.6 ± 0.7**
Heart						
Absolute	0.135 ± 0.016	0.121 ± 0.004	0.117 ± 0.004	0.117 ± 0.001	0.127 ± 0.009	0.105 ± 0.009
Relative	5.898 ± 0.717	5.441 ± 0.178	5.329 ± 0.222	5.656 ± 0.099	6.158 ± 0.525	6.272 ± 0.376
R. Kidney						
Absolute	0.188 ± 0.005	0.180 ± 0.006	0.181 ± 0.006	0.177 ± 0.004	0.174 ± 0.002	0.176 ± 0.011
Relative	8.198 ± 0.130	8.095 ± 0.286	8.256 ± 0.236	8.539 ± 0.165	8.375 ± 0.148	10.615 ± 0.570**
Liver						
Absolute	1.240 ± 0.024	1.246 ± 0.015	1.298 ± 0.033	1.240 ± 0.039	1.288 ± 0.043	1.081 ± 0.060*
Relative	54.128 ± 1.169	56.010 ± 0.453	59.271 ± 1.151**	59.782 ± 1.318**	61.869 ± 1.246**	64.791 ± 0.278**
Lung						
Absolute	0.197 ± 0.017	0.253 ± 0.011**	0.240 ± 0.008*	0.271 ± 0.013**	0.334 ± 0.012**	0.266 ± 0.011**
Relative	8.581 ± 0.742	11.366 ± 0.489*	10.973 ± 0.457*	13.066 ± 0.707**	16.088 ± 0.812**	16.122 ± 0.705**
Thymus						
Absolute	0.077 ± 0.006	0.079 ± 0.004	0.082 ± 0.006	0.082 ± 0.006	0.074 ± 0.007	0.036 ± 0.008**
Relative	3.371 ± 0.291	3.552 ± 0.175	3.733 ± 0.279	3.955 ± 0.290	3.537 ± 0.320	2.147 ± 0.404*

* Significantly different ($P \leq 0.05$) from the chamber control group by Williams' or Dunnett's test

** $P \leq 0.01$

^a Organ weights (absolute weights) and body weights are given in grams; organ-weight-to-body-weight ratios (relative weights) are given as mg organ weight/g body weight (mean ± standard error).

^b No data were available for the 32 mg/m³ group due to 100% mortality.

TABLE H4
Organ Weights and Organ-Weight-to-Body-Weight Ratios for Mice in the 3-Month Inhalation Study of Vanadium Pentoxide^a

	Chamber Control	1 mg/m ³	2 mg/m ³	4 mg/m ³	8 mg/m ³	16 mg/m ³
Male						
n	10	10	10	10	9	9
Necropsy body wt	35.4 ± 1.1	36.0 ± 0.8	36.2 ± 0.7	34.5 ± 0.5	33.4 ± 0.4**	32.0 ± 0.6
Heart						
Absolute	0.193 ± 0.012	0.180 ± 0.010	0.192 ± 0.008	0.171 ± 0.007	0.179 ± 0.014	0.172 ± 0.005
Relative	5.510 ± 0.430	4.980 ± 0.216	5.317 ± 0.260	4.975 ± 0.244	5.308 ± 0.346	5.380 ± 0.128
R. Kidney						
Absolute	0.329 ± 0.014	0.345 ± 0.014	0.354 ± 0.009	0.336 ± 0.008	0.334 ± 0.010	0.324 ± 0.008
Relative	9.310 ± 0.399	9.588 ± 0.335	9.829 ± 0.411	9.796 ± 0.340	9.984 ± 0.218	10.161 ± 0.285
Liver						
Absolute	1.633 ± 0.062	1.871 ± 0.041*	1.871 ± 0.043*	1.554 ± 0.055	1.704 ± 0.068	1.675 ± 0.051
Relative	46.191 ± 1.432	52.058 ± 0.753*	51.809 ± 1.270*	45.234 ± 1.854	50.820 ± 1.536	52.405 ± 1.284*
Lung						
Absolute	0.246 ± 0.008	0.250 ± 0.010	0.282 ± 0.007**	0.319 ± 0.006**	0.334 ± 0.011**	0.404 ± 0.015**
Relative	6.962 ± 0.208	6.944 ± 0.207	7.823 ± 0.276	9.277 ± 0.218**	9.985 ± 0.279**	12.691 ± 0.544**
R. Testis						
Absolute	0.128 ± 0.003	0.129 ± 0.005	0.127 ± 0.003	0.128 ± 0.003	0.120 ± 0.002	0.124 ± 0.002
Relative	3.632 ± 0.119	3.592 ± 0.115	3.527 ± 0.109	3.706 ± 0.090	3.586 ± 0.083	3.895 ± 0.095
Thymus						
Absolute	0.050 ± 0.002 ^b	0.045 ± 0.002	0.047 ± 0.004	0.036 ± 0.004*	0.042 ± 0.004*	0.034 ± 0.003**
Relative	1.437 ± 0.068 ^b	1.267 ± 0.059	1.299 ± 0.128	1.059 ± 0.107*	1.258 ± 0.110	1.083 ± 0.111
Female						
n	10	10	10	10	10	10
Necropsy body wt	31.1 ± 1.0	29.7 ± 0.8	29.6 ± 0.6	26.2 ± 0.4**	27.3 ± 0.4**	25.8 ± 0.4**
Heart						
Absolute	0.153 ± 0.003	0.143 ± 0.004	0.145 ± 0.003	0.151 ± 0.010	0.141 ± 0.003	0.141 ± 0.007
Relative	4.958 ± 0.169	4.858 ± 0.207	4.917 ± 0.126	5.748 ± 0.354*	5.158 ± 0.097	5.446 ± 0.215
R. Kidney						
Absolute	0.236 ± 0.006	0.235 ± 0.004	0.229 ± 0.005	0.220 ± 0.006	0.226 ± 0.006	0.231 ± 0.007
Relative	7.626 ± 0.238	7.958 ± 0.289	7.754 ± 0.168	8.385 ± 0.184*	8.281 ± 0.194*	8.943 ± 0.189**
Liver						
Absolute	1.600 ± 0.068	1.535 ± 0.042	1.575 ± 0.040	1.418 ± 0.046	1.481 ± 0.054	1.529 ± 0.052
Relative	51.525 ± 1.799	51.756 ± 1.166	53.390 ± 1.532	53.941 ± 1.167	54.248 ± 1.750	59.176 ± 1.463**
Lung						
Absolute	0.249 ± 0.011	0.261 ± 0.006	0.286 ± 0.014	0.345 ± 0.024**	0.360 ± 0.018**	0.422 ± 0.018**
Relative	8.094 ± 0.479	8.836 ± 0.337	9.704 ± 0.485	13.169 ± 0.901**	13.179 ± 0.637**	16.312 ± 0.492**
Thymus						
Absolute	0.061 ± 0.003	0.063 ± 0.004	0.062 ± 0.004	0.047 ± 0.005	0.056 ± 0.002	0.043 ± 0.003**
Relative	1.957 ± 0.105	2.116 ± 0.126	2.091 ± 0.133	1.795 ± 0.183	2.047 ± 0.097	1.645 ± 0.115

* Significantly different ($P \leq 0.05$) from the chamber control group by Williams' or Dunnett's test

** $P \leq 0.01$

^a Organ weights (absolute weights) and body weights are given in grams; organ-weight-to-body-weight ratios (relative weights) are given as mg organ weight/g body weight (mean ± standard error).

^b n=9

APPENDIX I

REPRODUCTIVE TISSUE EVALUATIONS AND ESTROUS CYCLE CHARACTERIZATION

TABLE I1	Summary of Reproductive Tissue Evaluations for Male Rats in the 3-Month Inhalation Study of Vanadium Pentoxide	290
TABLE I2	Estrous Cycle Characterization for Female Rats in the 3-Month Inhalation Study of Vanadium Pentoxide	290
TABLE I3	Summary of Reproductive Tissue Evaluations for Male Mice in the 3-Month Inhalation Study of Vanadium Pentoxide	291
TABLE I4	Estrous Cycle Characterization for Female Mice in the 3-Month Inhalation Study of Vanadium Pentoxide	291

TABLE I1
Summary of Reproductive Tissue Evaluations for Male Rats in the 3-Month Inhalation Study of Vanadium Pentoxide^a

	Chamber Control	2 mg/m ³	4 mg/m ³	8 mg/m ³
n	10	10	10	10
Weights (g)				
Necropsy body wt	350 ± 8	339 ± 6	334 ± 7	319 ± 7**
L. Cauda epididymis	0.1742 ± 0.0062	0.1666 ± 0.0042	0.1809 ± 0.0043	0.1768 ± 0.0056
L. Epididymis	0.4967 ± 0.0076	0.4756 ± 0.0081	0.4896 ± 0.0097	0.5075 ± 0.0050
L. Testis	1.4960 ± 0.0292	1.4606 ± 0.0326	1.5077 ± 0.0265	1.4908 ± 0.0183
Spermatid measurements				
Spermatid heads (10 ⁷ /g testis)	9.70 ± 0.44	9.89 ± 0.58	9.35 ± 0.39	8.91 ± 0.42
Spermatid heads (10 ⁷ /testis)	14.42 ± 0.49	14.34 ± 0.72	14.08 ± 0.59	13.30 ± 0.69
Spermatid count (mean/10 ⁻⁴ mL suspension)	72.10 ± 2.45	71.70 ± 3.59	70.40 ± 2.94	66.50 ± 3.45
Epididymal spermatozoal measurements				
Motility (%)	85.68 ± 1.77	85.51 ± 2.21	87.69 ± 1.47	80.14 ± 2.45
Concentration (10 ⁶ /g cauda epididymal tissue)	427 ± 15	463 ± 11	436 ± 28	386 ± 24

** Significantly different (P ≤ 0.01) from the chamber control group by Williams' test

^a Data are presented as mean ± standard error. Differences from the chamber control group are not significant by Dunnett's test (tissue weights) or Dunn's test (spermatid and epididymal spermatozoal measurements).

TABLE I2
Estrous Cycle Characterization for Female Rats in the 3-Month Inhalation Study of Vanadium Pentoxide^a

	Chamber Control	4 mg/m ³	8 mg/m ³	16 mg/m ³
n	10	10	10	8
Necropsy body wt	198 ± 3	196 ± 4	189 ± 4	117 ± 5**
Estrous cycle length (days)	5.00 ± 0.00	5.00 ± 0.08	5.50 ± 0.14** ^b	5.25 ± 0.25 ^c
Estrous stages (% of cycle)				
Diestrus	39.2	40.8	49.2	71.9
Proestrus	18.3	16.7	15.8	10.4
Estrus	20.8	19.2	17.5	10.4
Metestrus	21.7	22.5	17.5	7.3
Uncertain diagnoses	0.0	0.8	0.0	0.0

** Significantly different (P ≤ 0.01) from the chamber control group by Williams' test (necropsy body weight) or Shirley's test (estrous cycle length)

^a Necropsy body weight and estrous cycle length data are presented as mean ± standard error. By multivariate analysis of variance, exposed females do not differ significantly from the chamber control females in the relative length of time spent in the estrous stages.

^b Estrous cycle was longer than 12 days or was unclear in 1 of 10 animals.

^c Estrous cycle was longer than 12 days or was unclear in six of eight animals.

TABLE I3
Summary of Reproductive Tissue Evaluations for Male Mice in the 3-Month Inhalation Study of Vanadium Pentoxide^a

	Chamber Control	4 mg/m ³	8 mg/m ³	16 mg/m ³
n	10	10	10	9
Weights (g)				
Necropsy body wt	35.4 ± 1.1	34.5 ± 0.5	33.4 ± 0.4	32.0 ± 0.6**
L. Cauda epididymis	0.0170 ± 0.0010	0.0174 ± 0.0006	0.0180 ± 0.0006	0.0165 ± 0.0009
L. Epididymis	0.0525 ± 0.0012	0.0505 ± 0.0013	0.0546 ± 0.0013	0.0512 ± 0.0013
L. Testis	0.1209 ± 0.0025	0.1217 ± 0.0014	0.1166 ± 0.0020	0.1163 ± 0.0018
Spermatid measurements				
Spermatid heads (10 ⁷ /g testis)	17.97 ± 0.67	15.99 ± 0.71	17.93 ± 0.74	17.67 ± 0.74
Spermatid heads (10 ⁷ /testis)	2.17 ± 0.09	1.94 ± 0.08	2.09 ± 0.09	2.05 ± 0.08
Spermatid count (mean/10 ⁻⁴ mL suspension)	67.83 ± 2.68	60.68 ± 2.50	62.28 ± 2.89	64.06 ± 2.47
Epididymal spermatozoal measurements				
Motility (%)	88.63 ± 0.90 ^b	86.23 ± 1.64	77.10 ± 3.15** ^b	83.11 ± 2.48* ^c
Concentration (10 ⁶ /g cauda epididymal tissue)	894 ± 57	915 ± 55	818 ± 39	849 ± 98

* Significantly different (P ≤ 0.05) from the chamber control group by Shirley's test

** Significantly different (P ≤ 0.01) from the chamber control group by Williams' test (necropsy body weight) or Shirley's test (epididymal spermatozoal motility)

^a Data are presented as mean ± standard error. Differences from the chamber control group are not significant by Dunnett's test (tissue weights) or Dunn's test (spermatid measurements and epididymal spermatozoal concentration).

^b n=9

^c n=8

TABLE I4
Estrous Cycle Characterization for Female Mice in the 3-Month Inhalation Study of Vanadium Pentoxide^a

	Chamber Control	4 mg/m ³	8 mg/m ³	16 mg/m ³
n	10	10	10	10
Necropsy body wt	31.1 ± 1.0	26.2 ± 0.4**	27.3 ± 0.4**	25.8 ± 0.4**
Estrous cycle length (days)	4.25 ± 0.13	4.29 ± 0.15 ^b	4.05 ± 0.05	5.11 ± 0.51 ^c
Estrous stages (% of cycle)				
Diestrus	27.5	40.8	29.2	34.2
Proestrus	21.7	14.2	15.0	18.3
Estrus	29.2	26.7	33.3	30.8
Metestrus	21.7	18.3	22.5	15.8
Uncertain diagnoses	0.0	0.0	0.0	0.8

** Significantly different (P ≤ 0.01) from the chamber control group by Williams' test

^a Necropsy body weight and estrous cycle length data are presented as mean ± standard error. Differences from the chamber control group for estrous cycle length are not significant by Dunn's test. By multivariate analysis of variance, exposed females do not differ significantly from the chamber control females in the relative length of time spent in the estrous stages.

^b Estrous cycle was longer than 12 days or was unclear in 3 of 10 animals.

^c Estrous cycle was longer than 12 days or was unclear in 1 of 10 animals.

APPENDIX J

IMMUNOTOXICOLOGY STUDIES

TABLE J1	Selected Pulmonary Lavage Parameters for Male Rats and Female Mice in the 16-Day Inhalation Study of Vanadium Pentoxide	294
TABLE J2	<i>In Vitro</i> Phagocytic Activity and <i>In Vivo</i> Pulmonary Bactericidal Activity to [³⁵ S]- <i>Klebsiella pneumoniae</i> in Male Rats in the 16-Day Inhalation Study of Vanadium Pentoxide	295
TABLE J3	<i>In Vivo</i> Pulmonary Bactericidal Activity to [³⁵ S]- <i>Klebsiella pneumoniae</i> in Female Mice in the 16-Day Inhalation Study of Vanadium Pentoxide	295
TABLE J4	Alveolar Macrophage Production of Hydrogen Peroxide and Tumor Necrosis Factor in Male Rats and Female Mice in the 16-Day Inhalation Study of Vanadium Pentoxide ..	296
TABLE J5	Influenza Virus Challenge Results for Female Mice in the 16-Day Inhalation Study of Vanadium Pentoxide	296
TABLE J6	Mixed Lymphocyte Culture Results for Female Mice in the 16-Day Inhalation Study of Vanadium Pentoxide	297
TABLE J7	Cytotoxic T Cell Response Results for Female Mice in the 16-Day Inhalation Study of Vanadium Pentoxide	297

TABLE J1
Selected Pulmonary Lavage Parameters for Male Rats and Female Mice in the 16-Day Inhalation Study of Vanadium Pentoxide^a

	Chamber Control	4 mg/m ³	8 mg/m ³	16 mg/m ³
n	10	10	10	10
Male Rats				
Viability (%)	93 ± 4	95 ± 2	94 ± 4	94 ± 2
Total cells (10 ⁶)	11.07 ± 1.9	18.61 ± 6.6*	18.94 ± 8.3 ^b	21.70 ± 7.7*
Macrophages (%)	98 ± 2	91 ± 8	78 ± 14*	69 ± 10*
Lymphocytes (%)	2 ± 2	3 ± 4	7 ± 4	7 ± 5
Neutrophils (%)	0 ± 0	6 ± 6	16 ± 16*	25 ± 12*
Lavage fluid protein (µg/mL)	117 ± 32	221 ± 23*	268 ± 38*	253 ± 38*
Lysozyme (µg/mL)	60 ± 2	65 ± 3*	65 ± 5*	71 ± 4*
Lysozyme (µg/µg protein)	0.54 ± 0.14	0.30 ± 0.03*	0.24 ± 0.03*	0.28 ± 0.04*
Female Mice				
Viability (%)	83 ± 12 ^b	87 ± 5	94 ± 4*	90 ± 7
Total cells (10 ⁶)	3.42 ± 3.15 ^b	9.03 ± 4.98	12.38 ± 7.20*	15.37 ± 12.02*
Macrophages (%)	99 ± 1	95 ± 4	88 ± 10*	80 ± 10*
Lymphocytes (%)	1 ± 1	5 ± 4*	5 ± 4*	5 ± 3*
Neutrophils (%)	0 ± 0	0 ± 0	7 ± 8	15 ± 10*
Lavage fluid protein (µg/mL)	124 ± 87	187 ± 37*	207 ± 41*	262 ± 47*
Lysozyme (µg/mL)	20 ± 3	29 ± 5*	31 ± 3*	29 ± 4*
Lysozyme (µg/µg protein)	0.21 ± 0.09	0.16 ± 0.03	0.15 ± 0.04	0.11 ± 0.02*

* Significantly different (P ≤ 0.05) from the chamber control group by Dunnett's test

^a Data are presented as mean ± standard deviation.

^b n=9

TABLE J2
***In Vitro* Phagocytic Activity and *In Vivo* Pulmonary Bactericidal Activity to [³⁵S]-*Klebsiella pneumoniae* in Male Rats in the 16-Day Inhalation Study of Vanadium Pentoxide^a**

	Chamber Control	4 mg/m ³	8 mg/m ³	16 mg/m ³
n	10	10	10	10
Phagocytosis (CPM)	5,993 ± 646	4,068 ± 440*	4,513 ± 476*	4,134 ± 343*
Bactericidal activity (%) ^b	79.1 ± 7.7	89.1 ± 3.9*	89.7 ± 3.7* ^c	84.7 ± 1.8 ^c

* Significantly different ($P \leq 0.05$) from the chamber control group by Dunnett's test

^a Data are presented as mean ± standard deviation; CPM=counts per minute.

^b Percent bactericidal activity= $(1 - R_3/K_0) \times 100$, where R_3 is the ratio of bacterial to radioactive counts at 3 hours and K_0 is an average determined from the same ratios in the lungs of eight rats at 0 hours.

^c n=9

TABLE J3
***In Vivo* Pulmonary Bactericidal Activity to [³⁵S]-*Klebsiella pneumoniae* in Female Mice in the 16-Day Inhalation Study of Vanadium Pentoxide^a**

	Chamber Control	4 mg/m ³	8 mg/m ³	16 mg/m ³
n	10	10	10	9
Bactericidal activity (%)	86.1 ± 3.2	71.8 ± 11.3	75.5 ± 6.3	77.9 ± 22.6

^a Data are presented as mean ± standard deviation. Percent bactericidal activity= $(1 - R_3/K_0) \times 100$, where R_3 is the ratio of bacterial to radioactive counts at 3 hours and K_0 is an average determined from the same ratios in the lungs of six mice at 0 hours.

TABLE J4
Alveolar Macrophage Production of Hydrogen Peroxide and Tumor Necrosis Factor
in Male Rats and Female Mice in the 16-Day Inhalation Study of Vanadium Pentoxide

	Chamber Control	4 mg/m ³	8 mg/m ³	16 mg/m ³
Male Rats				
n	10	10	10	10
μmol H ₂ O ₂ ×10 ⁻⁴ /10 ⁶ alveolar macrophages (-lipopolysaccharide) ^a	3.9 ± 0.9	12.9 ± 5.4*	14.6 ± 12.3* ^b	14.1 ± 8.4*
μmol H ₂ O ₂ ×10 ⁻⁴ /10 ⁶ alveolar macrophages (+lipopolysaccharide) ^a	3.8 ± 0.9	11.3 ± 3.8*	9.7 ± 7.2* ^c	12.2 ± 5.8*
Tumor necrosis factor production ^d	0.106 ± 0.003	0.127 ± 0.002*	0.150 ± 0.002*	0.139 ± 0.002*
Female Mice				
n	5	5	5	5
μmol H ₂ O ₂ ×10 ⁻⁴ /10 ⁶ alveolar macrophages (-lipopolysaccharide)	— ^e	3.81 ± 1.07 ^f	1.56 ± 0.53 ^g	5.53 ± 3.16 ^f
μmol H ₂ O ₂ ×10 ⁻⁴ /10 ⁶ alveolar macrophages (+lipopolysaccharide)	6.89 ± 5.84	7.54 ± 4.12	8.15 ± 6.24	6.84 ± 4.21
Tumor necrosis factor production	0.312 ± 0.023	0.231 ± 0.036	0.168 ± 0.024*	0.184 ± 0.029*

* Significantly different (P≤0.05) from the chamber control group by Dunnett's test

^a Data are presented as mean ± standard deviation.

^b n=9

^c n=8

^d Data are presented as mean ± standard error; tumor necrosis factor production is expressed as absorbance [550 nm (rats) or 540 nm (mice)] of neutral red uptake by L-929 monolayers in the presence of actinomycin D. Absorbance is inversely proportional to tumor necrosis factor-α concentration.

^e Not examined for this exposure group

^f n=3

^g n=2

TABLE J5
Influenza Virus Challenge Results for Female Mice in the 16-Day Inhalation Study of Vanadium Pentoxide

	Chamber Control	4 mg/m ³	8 mg/m ³	16 mg/m ³
n	20	20	20	20
Number of moribund mice	2	2	2	3
Moribundity (%)	10	10	10	15
Mean survival (days)	13.6	13.6	13.7	13.6

TABLE J6
Mixed Lymphocyte Culture Results for Female Mice in the 16-Day Inhalation Study of Vanadium Pentoxide^a

	Chamber Control	4 mg/m ³	8 mg/m ³	16 mg/m ³
n	7	8	7	8
Mixed lymphocyte culture	61,540 ± 3,785	39,036 ± 6,491	49,310 ± 7,967	50,173 ± 6,041

^a Data are presented as mean ± standard error of net counts per minute (with DBA/2 allogenic lymphocytes minus spontaneous release).

TABLE J7
Cytotoxic T Cell Response Results for Female Mice in the 16-Day Inhalation Study of Vanadium Pentoxide^a

Effector:Target Cell Ratio	Chamber Control	4 mg/m ³	8 mg/m ³	16 mg/m ³
n	8	8	8	8
25:1	78.0 ± 2.6	75.3 ± 2.1	78.7 ± 1.0	78.1 ± 1.4
12:1	69.1 ± 3.6	67.3 ± 2.7	72.7 ± 3.6	70.4 ± 3.8
6:1	59.4 ± 2.2	59.6 ± 3.0 ^b	63.0 ± 2.5	58.6 ± 2.9

^a Data are presented as mean ± standard error of percent specific cytotoxicity of cytotoxic T cells against P815 tumor target cells in a 4-hour, chromium-release assay.

^b n=7

APPENDIX K

TISSUE BURDEN RESULTS

LUNG CLEARANCE EQUATIONS USED IN THE 16-DAY SPECIAL STUDIES OF VANADIUM PENTOXIDE	300
LUNG DEPOSITION AND CLEARANCE EQUATIONS USED IN THE 2-YEAR INHALATION STUDIES OF VANADIUM PENTOXIDE	301
TABLE K1 Lung Weight and Lung Burden in Female Rats in the 16-Day Special Study of Vanadium Pentoxide	302
TABLE K2 Lung Clearance Parameters with Error Estimates and 95% Confidence Intervals for Female Rats in the 16-Day Special Study of Vanadium Pentoxide	303
TABLE K3 Blood Vanadium Concentrations in Female Rats in the 16-Day Special Study of Vanadium Pentoxide	304
TABLE K4 Lung Weight and Lung Burden in Female Rats in the 2-Year Inhalation Study of Vanadium Pentoxide	305
TABLE K5 Lung Deposition and Clearance Parameters with Error Estimates and 95% Confidence Intervals for Female Rats in the 2-Year Inhalation Study of Vanadium Pentoxide	306
TABLE K6 Blood Vanadium Concentrations in Female Rats in the 2-Year Inhalation Study of Vanadium Pentoxide	307
TABLE K7 Lung Weight and Lung Burden in Female Mice in the 16-Day Special Study of Vanadium Pentoxide	308
TABLE K8 Lung Clearance Parameters with Error Estimates and 95% Confidence Intervals for Female Mice in the 16-Day Special Study of Vanadium Pentoxide	309
TABLE K9 Lung Weight and Lung Burden in Female Mice in the 2-Year Inhalation Study of Vanadium Pentoxide	310
TABLE K10 Lung Deposition and Clearance Parameters with Error Estimates and 95% Confidence Intervals for Female Mice in the 2-Year Inhalation Study of Vanadium Pentoxide	311
TABLE K11 Blood Vanadium Concentrations in Female Mice in the 2-Year Inhalation Study of Vanadium Pentoxide	312

TISSUE BURDEN RESULTS

LUNG CLEARANCE EQUATIONS USED IN THE 16-DAY SPECIAL STUDIES OF VANADIUM PENTOXIDE

Lung clearance rates from postexposure data were calculated using Equation (1).

$$\text{Equation (1)} \quad A(t) = A_0(e^{-kt})$$

In Equation (1), $A(t)$ is the lung burden (μg vanadium) at postexposure time t (days); A_0 is the amount of vanadium in the lungs at the beginning of the postexposure period ($t=0$); and k is the first-order lung clearance rate constant (days^{-1}).

Using values of k and A_0 determined from Equation (1), the lung clearance half-time ($t_{1/2}$, days) was calculated from Equation (2).

$$\text{Equation (2)} \quad t_{1/2} = \ln 2/k$$

The area under the lung burden versus time curve (AUC_T) was calculated using the trapezoidal rule according to the following formula:

$$\text{AUC}_T = \sum \frac{B_{n-1} + B_n}{2} \times (t_n - t_{n-1})$$

where B_{n-1} and B_n represent lung burdens at consecutive time points t_{n-1} and t_n .

LUNG DEPOSITION AND CLEARANCE EQUATIONS USED IN THE 2-YEAR INHALATION STUDIES OF VANADIUM PENTOXIDE

Lung deposition and clearance parameters were calculated from vanadium lung burden data during the 2-year studies using a model that assumes a constant (zero order) deposition rate and first-order elimination rate, but the results were not satisfactory. Instead, a model that was based on a linear differential equation to account for proportional (first-order) deposition and proportional (first-order) elimination rates of vanadium in the lung was used. This model provided a better fit to the lung burden data over the 18-month period. The model used is described by Equation (1).

$$\text{Equation (1)} \quad dV/dt = k_d \cdot e^{-k_r t} - k_e \cdot V$$

V is the mass of vanadium (μg) in the lung at time t; t is time (days); k_d is the initial deposition rate constant ($\mu\text{g}/\text{day}$); k_r is the deposition rate change (day^{-1}); and k_e is the elimination rate constant (day^{-1}). The solution of this differential equation, with the boundary condition of $V=0$ at $t=0$, is described in Equation (2).

$$\text{Equation (2)} \quad V(t) = [k_d/(k_e - k_r)] \cdot (e^{-k_r t} - e^{-k_e t})$$

Estimates and uncertainties of toxicokinetic parameters (k_d , k_r , and k_e) were estimated using SAS PROC NLIN (SAS Institute, Inc.) by fitting the model to the lung burden data at each exposure concentration. Based on these parameters, the lung deposition rate half-time ($t_{r1/2}$, day) and the lung elimination half-time ($t_{e1/2}$, day) can be calculated from Equations (3) and (4), respectively.

$$\text{Equation (3)} \quad t_{r1/2} = 0.693/k_r$$

$$\text{Equation (4)} \quad t_{e1/2} = 0.693/k_e$$

The area under the lung burden versus time curve from the start of the study to the terminal time point (AUC_T) was calculated using the trapezoidal rule according to the following formula:

$$AUC_T = \sum \frac{B_{n-1} + B_n}{2} \times (t_n - t_{n-1})$$

where B_{n-1} and B_n represent lung burdens at consecutive time points t_{n-1} and t_n . Values for k_d and AUC_T were also normalized to exposure concentration to determine whether the values were dependent on exposure concentration.

The lung burden data for each group and time point were also normalized by dividing the lung burdens by the exposure concentration. These data were tested for dose proportionality using PROC GLM in SAS. This analysis initially involved two-way ANOVA of exposure concentration and time on study. The exposure effect was significant as well as some of the interaction terms. Therefore, a final one-way ANOVA was run for each time point.

TABLE K1
Lung Weight and Lung Burden in Female Rats in the 16-Day Special Study of Vanadium Pentoxide^a

	Chamber Control	1 mg/m ³	2 mg/m ³
n	4	4	4
Absolute lung wt. (g)			
Postexposure day 0	0.6270 ± 0.0244	0.8581 ± 0.0487**	0.8149 ± 0.0516**
Postexposure day 1	0.6003 ± 0.0569	0.8529 ± 0.0332**	0.9216 ± 0.0285**
Postexposure day 4	0.6487 ± 0.0502	0.7815 ± 0.0467**	0.7986 ± 0.0263**
Postexposure day 8	0.7193 ± 0.0535	0.7732 ± 0.0271	0.7711 ± 0.0159
µg V/lung			
Postexposure day 0	— ^b	4.32 ± 0.29	8.05 ± 1.16
Postexposure day 1	—	3.20 ± 0.16	5.79 ± 1.10
Postexposure day 4	—	2.02 ± 0.21	3.60 ± 0.54
Postexposure day 8	—	1.41 ± 0.25	3.17 ± 0.71
µg V/g lung			
Postexposure day 0	— ^c	5.04 ± 0.27	9.89 ± 1.38
Postexposure day 1	—	3.76 ± 0.27	6.28 ± 1.21
Postexposure day 4	—	2.58 ± 0.17	4.50 ± 0.54
Postexposure day 8	—	1.82 ± 0.27	4.11 ± 0.89
µg V/lung per mg V ₂ O ₅ /m ³			
Postexposure day 0	NA	4.32 ± 0.29	4.02 ± 0.58
Postexposure day 1	NA	3.20 ± 0.16	2.89 ± 0.55
Postexposure day 4	NA	2.02 ± 0.21	1.80 ± 0.27
Postexposure day 8	NA	1.41 ± 0.25	1.59 ± 0.36

(NA)Not applicable

** Significantly different (P≤0.01) from the chamber control group by Dunn's or Williams' test.

^a Data are presented as mean ± standard deviation.

^b The value was below the estimated limit of detection (0.034 µg V/lung).

^c The value was below the estimated limit of detection (0.034 µg V/g lung).

TABLE K2
Lung Clearance Parameters with Error Estimates and 95% Confidence Intervals
for Female Rats in the 16-Day Special Study of Vanadium Pentoxide^a

Parameter	Exposure Concentration (mg/m ³)	Estimated Value	Standard Error	95% Confidence Interval	
				Lower Limit	Upper Limit
A_0	1	4.07	0.14	3.78	4.37
	2	7.39	0.45	6.42	8.35
k	1	0.157	0.015	0.124	0.189
	2	0.140	0.025	0.0858	0.193
$t_{1/2}$	1	4.42	0.43	3.51	5.34
	2	4.96	0.89	3.05	6.88
AUC_T	1	18.4	0.4	17.5	19.3
	2	34.6	1.3	31.6	37.6
$AUC_T/Exposure\ Concentration$	1	18.4	0.4	17.5	19.3
	2	17.3	0.7	15.8	18.8

^a n=16; A_0 =initial postexposure lung burden ($\mu\text{g V}$), k =first order lung clearance rate constant (days^{-1}), $t_{1/2}=\ln 2/k$ (days), AUC_T =area under the lung burden (trapezoids) versus time curve using the means of the data to the end (postexposure day 8), $AUC_T/Exposure\ Concentration$ =area under the lung burden (trapezoids) versus time curve using the means of the data to the end (postexposure day 8) and normalized to exposure concentration

TABLE K3
Blood Vanadium Concentrations in Female Rats in the 16-Day Special Study of Vanadium Pentoxide^a

	Chamber Control	1 mg/m ³	2 mg/m ³
n	5	5	5
µg V/g blood			
Postexposure day 0	0.115 ± 0.017	0.182 ± 0.035	0.194 ± 0.024
Postexposure day 1	0.197 ± 0.030	0.179 ± 0.021	0.208 ± 0.045
Postexposure day 4	0.114 ± 0.017	0.150 ± 0.016	0.168 ± 0.024
Postexposure day 8	0.136 ± 0.011	0.154 ± 0.023	0.177 ± 0.006

^a Data are presented as mean ± standard deviation; the experimental limit of quantitation=0.10 µg V/g blood.

TABLE K4
Lung Weight and Lung Burden in Female Rats in the 2-Year Inhalation Study of Vanadium Pentoxide^a

	0.5 mg/m ³	1 mg/m ³	2 mg/m ³
Absolute lung wt (g)			
Day 1	0.57 ± 0.05	0.56 ± 0.03	0.54 ± 0.04
Day 5	0.59 ± 0.04	0.61 ± 0.04	0.62 ± 0.04
Day 12	0.68 ± 0.04	0.75 ± 0.04	0.80 ± 0.05
Day 26	0.79 ± 0.08	0.89 ± 0.05	0.95 ± 0.08
Day 54	1.05 ± 0.06	1.00 ± 0.06	1.14 ± 0.06
Day 173	1.1 ± 0.1	1.12 ± 0.05	1.34 ± 0.07
Day 360	1.1 ± 0.1	1.20 ± 0.06	1.43 ± 0.04
Day 542	1.20 ± 0.05	1.33 ± 0.05	1.56 ± 0.04
µg V/lung			
Day 1	0.94 ± 0.07	2.3 ± 0.1	4.5 ± 0.4
Day 5	3.1 ± 0.1	6.0 ± 0.3	10.9 ± 0.4
Day 12	3.0 ± 0.1	5.5 ± 0.3	8.9 ± 0.5
Day 26	4.7 ± 0.7	8.4 ± 0.3	13 ± 1
Day 54	7.6 ± 0.7	14 ± 1	24 ± 2
Day 173	12.6 ± 0.9	29 ± 2	53 ± 4
Day 360	12.3 ± 0.8	25 ± 2	45 ± 5
Day 542	13.5 ± 0.4	23 ± 2	46 ± 5
µg V/g lung			
Day 1	1.6 ± 0.2	4.0 ± 0.3	8.3 ± 0.3
Day 5	5.2 ± 0.3	10 ± 1	18 ± 1
Day 12	4.5 ± 0.2	7.4 ± 0.8	11.1 ± 0.7
Day 26	5.9 ± 0.7	9.4 ± 0.3	14 ± 1
Day 54	7.2 ± 0.4	14 ± 1	20.8 ± 0.9
Day 173	11.8 ± 0.6	26 ± 2	39 ± 4
Day 360	11.0 ± 0.5	21 ± 2	31 ± 3
Day 542	11.2 ± 0.2	18 ± 1	30 ± 3
µg V/lung per mg V ₂ O ₅ /m ³			
Day 1	1.9 ± 0.1	2.3 ± 0.1	2.2 ± 0.2
Day 5	6.2 ± 0.3	6.0 ± 0.3	5.4 ± 0.2
Day 12	6.1 ± 0.3	5.5 ± 0.3	4.4 ± 0.2
Day 26	9 ± 1	8.4 ± 0.3	6.4 ± 0.6
Day 54	15 ± 1	14 ± 1	12 ± 1
Day 173	25 ± 2	29 ± 2	26 ± 2
Day 360	25 ± 2	25 ± 2	22 ± 3
Day 542	26.9 ± 0.8	23 ± 2	23 ± 2

^a Data are presented as mean ± standard deviation; n=4 or 5.

TABLE K5
Lung Deposition and Clearance Parameters with Error Estimates and 95% Confidence Intervals
for Female Rats in the 2-Year Inhalation Study of Vanadium Pentoxide

Parameter ^a	Exposure Concentration (mg/m ³)	Estimated Value	Standard Error	95% Confidence Interval	
				Lower Limit	Upper Limit
k_d	0.5	0.240	0.018	0.203	0.277
	1	0.415	0.033	0.349	0.481
	2	0.683	0.067	0.548	0.818
k_r	0.5	0	0.00017	-0.00035	0.00035
	1	0.00097	0.00030	0.00036	0.00158
	2	0.00070	0.00035	-0.00001	0.00141
k_e	0.5	0.0186	0.0022	0.0141	0.0231
	1	0.0118	0.0019	0.0080	0.0156
	2	0.0113	0.0022	0.0068	0.0158
AUC _T	0.5	6,141	71	5,997	6,285
	1	12,466	176	12,109	12,823
	2	22,637	402	21,822	23,452
AUC _T /Exposure Concentration	0.5	12,281	142	11,994	12,568
	1	12,466	176	12,109	12,823
	2	11,318	201	10,910	11,726
$t_{r1/2}$ ^b	0.5	NA	NA	NA	NA
	1	715	221	268	1,162
	2	989	496	-12	1,990
$t_{e1/2}$	0.5	37.3	4.5	28.3	46.3
	1	58.6	9.3	39.9	77.3
	2	61.4	12.0	37.1	85.7

(NA)Not applicable

^a k_d =initial deposition ($\mu\text{g V/day}$), k_r =deposition rate change (day^{-1}), k_e =elimination rate (day^{-1}), AUC_T=area under the lung burden (trapezoids) versus time curve at termination ($\mu\text{g} \cdot \text{day}$), AUC_T/Exposure Concentration=area under the lung burden (trapezoids) versus time curve at termination normalized to exposure concentration, $t_{r1/2}$ =deposition half-time (days), $t_{e1/2}$ =elimination half-time (days)

^b For these data, the estimates for k_r are small with relatively large standard errors resulting in wide confidence intervals on the half-times. Thus, the estimated half-times reported above are imprecise and should be interpreted with some caution.

TABLE K6
Blood Vanadium Concentrations in Female Rats in the 2-Year Inhalation Study of Vanadium Pentoxide^a

	Chamber Control	0.5 mg/m ³	1 mg/m ³	2 mg/m ³
n	5	5	5	5
µg V/g blood				
Day 26	0.30 ± 0.05	0.34 ± 0.03	0.33 ± 0.01	0.38 ± 0.07
Day 54	0.23 ± 0.11	0.35 ± 0.04	0.33 ± 0.02	0.37 ± 0.05
Day 173	0.21 ± 0.00	0.24 ± 0.01 _b	0.27 ± 0.01	0.35 ± 0.03
Day 360	0.21 ± 0.01	0.26 ± 0.02 _b	0.27 ± 0.01	0.31 ± 0.03
Day 542	0.22 ± 0.01	0.24 ± 0.01 _c	0.28 ± 0.01	0.33 ± 0.01

^a Data are presented as mean ± standard deviation; the experimental limit of quantitation=0.10 µg V/g blood.

^b n=4

^c n=3

TABLE K7
Lung Weight and Lung Burden in Female Mice in the 16-Day Special Study of Vanadium Pentoxide^a

	Chamber Control	2 mg/m ³	4 mg/m ³
n	4	4	3
Absolute lung wt. (g)			
Postexposure day 0	0.1430 ± 0.0209	0.2110 ± 0.0191**	0.2183 ± 0.0198**
Postexposure day 1	0.1438 ± 0.0116	0.1873 ± 0.0211**	0.2103 ± 0.0086**
Postexposure day 4	0.1398 ± 0.0173	0.1823 ± 0.0094**	0.1916 ± 0.0133**
Postexposure day 8	0.1435 ± 0.0125	0.1716 ± 0.0245	0.1706 ± 0.0145
µg V/lung			
Postexposure day 0	— ^b	2.09 ± 0.43	4.37 ± 0.30
Postexposure day 1	—	1.39 ± 0.20	2.52 ± 0.41
Postexposure day 4	—	0.628 ± 0.037	1.57 ± 0.13
Postexposure day 8	—	0.246 ± 0.040	0.757 ± 0.099
µg V/g lung			
Postexposure day 0	— ^c	9.89 ± 1.78	20.1 ± 1.9
Postexposure day 1	—	7.42 ± 0.74 ^d	12.9 ± 1.8
Postexposure day 4	—	3.45 ± 0.13 ^d	8.22 ± 0.95 ^d
Postexposure day 8	—	1.44 ± 0.13 ^d	4.43 ± 0.45 ^d
µg V/lung per mg V ₂ O ₅ /m ³			
Postexposure day 0	NA	1.04 ± 0.21	1.09 ± 0.07
Postexposure day 1	NA	0.694 ± 0.100	0.63 ± 0.103
Postexposure day 4	NA	0.314 ± 0.018	0.392 ± 0.033
Postexposure day 8	NA	0.123 ± 0.020	0.189 ± 0.025

** Significantly different ($P \leq 0.01$) from the chamber control group by Dunn's or Williams' test

^a Data are presented as mean ± standard deviation; NA = not applicable.

^b The value was below the estimated limit of detection (0.034 µg V/lung).

^c The value was below the estimated limit of detection (0.17 µg V/g lung).

^d The value was below the estimated limit of quantitation (5.00 µg V/g lung).

TABLE K8
Lung Clearance Parameters with Error Estimates and 95% Confidence Intervals
for Female Mice in the 16-Day Special Study of Vanadium Pentoxide^a

Parameter	Exposure Concentration (mg/m ³)	Estimated Value	Standard Error	95% Confidence Interval	
				Lower Limit	Upper Limit
A_0	2	1.92	0.10	1.70	2.13
	4	3.78	0.34	3.06	4.50
k	2	0.272	0.022	0.225	0.319
	4	0.289	0.039	0.205	0.374
$t_{1/2}$	2	2.55	0.21	2.11	2.99
	4	2.40	0.33	1.70	3.10
AUC_T	2	6.51	0.20	6.06	6.96
	4	14.6	0.4	13.6	15.6
$AUC_T/\text{Exposure Concentration}$	2	3.26	0.10	3.03	3.49
	4	3.66	0.11	3.40	3.92

^a n=16 (2 mg/kg) or 15 (4 mg/kg); A_0 =initial postexposure lung burden ($\mu\text{g V}$), k =first order lung clearance rate constant (days^{-1}), $t_{1/2}=\ln 2/k$ (days), AUC_T =area under the lung burden (trapezoids) versus time curve using the means of the data to the end (postexposure day 8), $AUC_T/\text{Exposure Concentration}$ = area under the lung burden (trapezoids) versus time curve using the means of the data to the end (postexposure day 8) and normalized to exposure concentration

TABLE K9
Lung Weight and Lung Burden in Female Mice in the 2-Year Inhalation Study
of Vanadium Pentoxide^a

	1 mg/m ³	2 mg/m ³	4 mg/m ³
n	5	5	5
Absolute lung wt (g)			
Day 1	0.13 ± 0.01	0.12 ± 0.02	0.14 ± 0.01
Day 5	0.13 ± 0.01	0.14 ± 0.01	0.14 ± 0.01
Day 12	0.16 ± 0.01	0.19 ± 0.02	0.25 ± 0.01
Day 26	0.22 ± 0.01	0.22 ± 0.02	0.26 ± 0.02
Day 54	0.23 ± 0.01	0.25 ± 0.02	0.27 ± 0.02
Day 171	0.21 ± 0.01	0.22 ± 0.01	0.25 ± 0.02
Day 362	0.23 ± 0.02	0.24 ± 0.02	0.25 ± 0.02 ^b
Day 535	0.28 ± 0.08	0.25 ± 0.02	0.32 ± 0.1 ^b
µg V/lung			
Day 1	0.6 ± 0.1	1.2 ± 0.2	2.5 ± 0.4
Day 5	1.45 ± 0.07	2.5 ± 0.2	4.2 ± 0.4
Day 12	1.5 ± 0.1	2.4 ± 0.1	3.7 ± 0.3
Day 26	3.0 ± 0.6	5 ± 1	9 ± 2
Day 54	2.6 ± 0.3	5.9 ± 0.6	11.3 ± 0.7
Day 171	2.7 ± 0.4	5.1 ± 0.4	10 ± 1
Day 362	3 ± 1	4 ± 1	8 ± 2 ^b
Day 535	2.3 ± 0.7	3.3 ± 0.7	6 ± 3 ^b
µg V/g lung			
Day 1	4.3 ± 0.6	10 ± 1	17 ± 2
Day 5	11 ± 1	17 ± 1	30 ± 4
Day 12	9.4 ± 0.6	13 ± 1	15 ± 2
Day 26	13 ± 3	24 ± 4	35 ± 9
Day 54	11 ± 1	24 ± 3	42 ± 2
Day 171	13 ± 2	23 ± 2	38 ± 2
Day 362	11 ± 4	18 ± 5	30 ± 6
Day 535	8 ± 1	13 ± 2	18 ± 11 ^b
µg V/lung per mg V ₂ O ₅ /m ³			
Day 1	0.6 ± 0.1	0.59 ± 0.08	0.6 ± 0.1
Day 5	1.45 ± 0.07	1.23 ± 0.08	1.04 ± 0.09
Day 12	1.5 ± 0.1	1.20 ± 0.05	0.93 ± 0.08
Day 26	3.0 ± 0.6	2.7 ± 0.5	2.3 ± 0.4
Day 54	2.6 ± 0.3	3.0 ± 0.3	2.8 ± 0.2
Day 171	2.7 ± 0.4	2.6 ± 0.2	2.4 ± 0.3
Day 362	3 ± 1	2.2 ± 0.7	1.9 ± 0.4 ^b
Day 535	2.3 ± 0.7	1.6 ± 0.4	1.4 ± 0.8 ^b

^a Data are presented as mean ± standard deviation.

^b n=4

TABLE K10
Lung Deposition and Clearance Parameters with Error Estimates and 95% Confidence Intervals
for Female Mice in the 2-Year Inhalation Study of Vanadium Pentoxide

Parameter ^a	Exposure Concentration (mg/m ³)	Estimated Value	Standard Error	95% Confidence Interval	
				Lower Limit	Upper Limit
k_d	1	0.311	0.055	0.200	0.422
	2	0.409	0.051	0.306	0.512
	4	0.618	0.084	0.449	0.787
k_r	1	0.00031	0.00023	-0.00016	0.00078
	2	0.00120	0.00025	0.00069	0.00171
	4	0.00155	0.00035	0.00085	0.00225
k_e	1	0.111	0.024	0.063	0.159
	2	0.0646	0.0108	0.0428	0.0864
	4	0.0497	0.0097	0.0302	0.0692
AUC_T	1	1,367	67	1,231	1,503
	2	2,457	86	2,282	2,632
	4	4,387	180	4,022	4,752
AUC_T /Exposure Concentration	1	1,367	67	1,231	1,503
	2	1,228	43	1,141	1,315
	4	1,097	45	1,006	1,188
$t_{r1/2}$ ^b	1	2,210	1,650	-1,110	5,530
	2	579	121	334	824
	4	447	100	244	650
$t_{e1/2}$	1	6.26	1.3	3.6	9.0
	2	10.7	1.8	7.1	14.3
	4	13.9	2.7	8.4	19.4

^a k_d =initial deposition ($\mu\text{g V/day}$), k_r =deposition rate change (day^{-1}), k_e =elimination rate (day^{-1}), AUC_T =area under the lung burden (trapezoids) versus time curve at termination ($\mu\text{g} \cdot \text{day}$), AUC_T /Exposure Concentration=area under the lung burden (trapezoids) versus time curve at termination normalized to exposure concentration, $t_{r1/2}$ =deposition half-time (days), $t_{e1/2}$ =elimination half-time (days)

^b For these data, the estimates for k_r are small with relatively large standard errors resulting in wide confidence intervals on the half-times. Thus, the estimated half-times reported above are imprecise and should be interpreted with some caution.

TABLE K11
Blood Vanadium Concentrations in Female Mice in the 2-Year Inhalation Study of Vanadium Pentoxide^a

	Chamber Control	1 mg/m ³	2 mg/m ³	4 mg/m ³
n	5	5	5	5
µg V/g blood				
Day 26	0.28 ± 0.08	0.38 ± 0.05 _b	0.42 ± 0.07	1.1 ± 0.3 _b
Day 54	0.5 ± 0.1	0.58 ± 0.05 _b	0.63 ± 0.07	0.91 ± 0.08 _b
Day 171	0.33 ± 0.02	0.40 ± 0.05	0.48 ± 0.04 _b	0.65 ± 0.08
Day 362	0.26 ± 0.01	0.39 ± 0.04	0.50 ± 0.05	0.76 ± 0.08 _b
Day 535	0.26 ± 0.02	0.36 ± 0.07 _c	0.47 ± 0.05	0.6 ± 0.1 _b

^a Data are presented as mean ± standard deviation; the experimental limit of quantitation=0.20 µg V/g blood.

^b n=4

^c n=3

APPENDIX L

CHEMICAL CHARACTERIZATION AND GENERATION OF CHAMBER CONCENTRATIONS *

PROCUREMENT AND CHARACTERIZATION OF VANADIUM PENTOXIDE	314
AEROSOL GENERATION AND EXPOSURE SYSTEM	315
AEROSOL CONCENTRATION MONITORING	316
CHAMBER ATMOSPHERE CHARACTERIZATION	316
FIGURE L1 Infrared Absorption Spectrum of Vanadium Pentoxide	319
FIGURE L2 Schematic of the Aerosol Generation System in the 16-Day and 3-Month Inhalation Studies of Vanadium Pentoxide	320
FIGURE L3 Schematic of the Aerosol Delivery System in the 16-Day and 3-Month Inhalation Studies of Vanadium Pentoxide	321
FIGURE L4 Schematic of the Aerosol Generation and Delivery System in the 16-Day Special Studies and 2-Year Inhalation Studies of Vanadium Pentoxide	322
FIGURE L5 Schematic of the Linear Dust Feeder in the 16-Day Special Studies and 2-Year Inhalation Studies of Vanadium Pentoxide	323
TABLE L1 Summary of Chamber Concentrations in the 16-Day Inhalation Studies of Vanadium Pentoxide	324
TABLE L2 Summary of Chamber Concentrations in the 3-Month Inhalation Studies of Vanadium Pentoxide	324
TABLE L3 Summary of Chamber Concentrations in the 16-Day Special Studies of Vanadium Pentoxide	325
TABLE L4 Summary of Chamber Concentrations in the 2-Year Inhalation Studies of Vanadium Pentoxide	325
TABLE L5 Summary of Aerosol Size Measurements for the Rat and Mouse Exposure Chambers in the 16-Day Inhalation Studies of Vanadium Pentoxide	326
TABLE L6 Summary of Aerosol Size Measurements for the Rat and Mouse Exposure Chambers in the 3-Month Inhalation Studies of Vanadium Pentoxide	326
TABLE L7 Summary of Aerosol Size Measurements for the Rat and Mouse Exposure Chambers in the 16-Day Special Studies of Vanadium Pentoxide	326
TABLE L8 Summary of Aerosol Size Measurements for the Rat Exposure Chambers in the 2-Year Inhalation Study of Vanadium Pentoxide	327
TABLE L9 Summary of Aerosol Size Measurements for the Mouse Exposure Chambers in the 2-Year Inhalation Study of Vanadium Pentoxide	328

* Additional information has been added to this report that is relevant to Appendix L, specifically Table L4. Please see the Addendum inserted after the title page. [May 9, 2022]

CHEMICAL CHARACTERIZATION AND GENERATION OF CHAMBER CONCENTRATIONS

PROCUREMENT AND CHARACTERIZATION OF VANADIUM PENTOXIDE

Vanadium pentoxide was obtained from Shieldalloy Metallurgical Corporation (Newfield, NJ) in two lots (1210490 and 1210140). Lot 1210490 was used in the 16-day and 3-month studies. Lot 1210140 was used in the 16-day special studies and the 2-year studies. Identity and purity analyses were conducted by the study laboratories and the analytical chemistry laboratories (Midwest Research Institute, Kansas City, MO, for lot 1210490; Research Triangle Institute, Research Triangle Park, NC, for lot 1210140). Reports on analyses performed in support of the vanadium pentoxide studies are on file at the National Institute of Environmental Health Sciences.

Lot 1210490, an orange, crystalline solid, was identified as vanadium pentoxide by the analytical chemistry laboratory using X-ray diffraction (XRD) analyses and infrared and ultraviolet/visible spectroscopy and by the study laboratory using infrared spectroscopy. Lot 1210140, a light orange, crystalline solid, was identified by the analytical chemistry laboratory using infrared and ultraviolet/visible spectroscopy and by the the study laboratory using XRD analysis. Infrared spectra were consistent between lots and with the structure of vanadium pentoxide (Nyquist and Kagel, 1971). A representative infrared spectrum of vanadium pentoxide is shown in Figure L1. XRD spectra were consistent with literature spectra (Joint Center for Powder Diffraction Studies/International Centre for Diffraction Data, PDF 41-1426) or with the structure of vanadium pentoxide. XRD analyses of both lots indicated the presence of vanadium pentoxide with no detectable contaminants.

The purity of lot 1210490 was determined by the analytical chemistry laboratory using elemental analyses, weight loss on drying, spark source mass spectrometry, energy-dispersive X-ray (EDX) spectroscopy, and potentiometric titration. Samples for EDX analysis were suspended in acetone and transferred to carbon stubs. The acetone was allowed to evaporate, and the samples were carbon coated under a vacuum. The X-ray spectrum of each sample was examined for particle size estimation and elemental composition, then the samples were quantitatively analyzed for purity. Samples for potentiometric titration were dissolved in 1 N sodium hydroxide and diluted with deionized water; 0.1 M copper sulfate was added and the pH was adjusted to 1.0 with concentrated hydrochloric acid. The samples were titrated against standardized 0.05 N sodium thiosulfate; the titration was monitored with a platinum billet indicator electrode and a calomel reference electrode filled with saturated potassium chloride. The purity of lot 1210140 was determined by the analytical chemistry laboratory using weight loss on drying, potentiometric titration, and inductively coupled argon plasma spectrometry and by the study laboratory using inductively coupled plasma/atomic emission spectroscopy (ICP/AES). Elemental analyses were performed by Galbraith Laboratories (Knoxville, TN). Samples for potentiometric titration were prepared as for lot 1210490 but with a combination platinum electrode. Samples for inductively coupled argon plasma spectrometry were dissolved in concentrated nitric acid, heated, and diluted with deionized water prior to analysis for trace elements. Samples for ICP/AES were dissolved in 2% nitric acid and analyzed for vanadium at 292.4 nm.

For lot 1210490, the result of elemental analysis for vanadium was in agreement with the theoretical value for vanadium pentoxide; carbon and hydrogen were also detected at concentrations of less than 0.5% each. Weight loss on drying indicated less than 0.06% volatile components. Spark source mass spectrometry indicated vanadium as the major component; the principal impurities were barium (170 ppm), iron (110 ppm), calcium (440 ppm), potassium (550 ppm), sulfur (270 ppm), silicon and sodium (approximately 1,100 ppm each), aluminum (260 ppm), and magnesium (340 ppm). The total concentration of all other impurities was 565 ppm. EDX analyses of lot 1210490 indicated the presence of vanadium pentoxide with minor amounts of sulfur, chlorine, and potassium. Potentiometric titration by the analytical chemistry laboratory indicated a purity of $103.1\% \pm 0.7\%$. The overall purity of lot 1210490 was determined to be approximately 99%. The study laboratory confirmed the purity upon receipt using potentiometric titration methods used by the analytical chemistry laboratory except using a platinum rod as an indicator electrode. The purity was determined to be 100.3% compared to a reference standard.

For lot 1210140, the result of elemental analysis for vanadium was in agreement with the theoretical value for vanadium pentoxide. Weight loss on drying indicated 1.2% water. Potentiometric titration indicated a purity of 99.0%. Results of inductively coupled argon plasma spectrometry indicated no trace elements at a concentration greater than 151 ppm. The overall purity was determined by the analytical chemistry laboratory to be approximately 99%. Results of ICP/AES analyses by the study laboratory were normalized against those of diluted reference standards obtained from the National Institute of Standards Technology (NIST). ICP/AES analysis indicated a purity of 101% of the theoretical value.

The analytical chemistry laboratory analyzed lot 1210140 for particle size using transmission electron microscopy and for agglomeration using polarized light optical microscopy. More than 90% of the individual particles were less than 1 micron in diameter. The individual particles formed aggregates ranging from 40 to 300 μm in diameter, with an average diameter of 170 μm .

Stability studies were performed by Dust Tech, Inc. (August, NJ), using a Hartmann Dust Explosion Apparatus (U.S. Bureau of Mines, Bruceton Station, PA). Results of these analyses indicated that vanadium pentoxide cannot ignite as a dispersed dust at concentrations up to 2,000 mg/m^3 when subjected to a 12,000 volt AC arc at a maximum of 360 watts. No heat stability studies were performed because literature references indicated that vanadium pentoxide is stable under normal storage temperatures. Stability was monitored by the study laboratories throughout the 16-day and 3-month studies with potentiometric titration as described for lot 1210140 and throughout the 16-day special studies and the 2-year studies with ICP/AES. No degradation of the bulk chemical was detected.

AEROSOL GENERATION AND EXPOSURE SYSTEM

For the 16-day and 3-month studies, vanadium pentoxide aerosol generation was based on the principle of pneumatic dispersion and consisted of two major components: a screw feeder (Model 310, Accurate, White Water, WI) that metered vanadium pentoxide powder at a constant rate and a Jet-O-Mizer jetmill (Fluid Energy Corp., Harfield, PA) that used compressed air to disperse the metered powder and form the aerosol (Figure L2). Aerosol leaving the jetmill passed through a one-stage impactor and a vertical elutriator to eliminate or deagglomerate the large particles before entering a plenum and manifold distribution system. The aerosol delivery system consisted of three holding chambers that diluted the aerosol in three stages (Figure L3). A metered amount of diluted aerosol was removed and mixed with conditioned air at the inlet to each exposure chamber to achieve the appropriate exposure concentration. The electrical charge buildup on the aerosol particles was neutralized by mixing the aerosol with high concentrations of bipolar ions that were generated using a Pulse Gun (Static Control Services, Palm Springs, CA) air nozzle. For the 3-month studies, a transvector air pump was installed at the aerosol inlet to each exposure chamber to provide additional control of the aerosol flow rate and improve stability of the chamber concentration.

The generation and delivery system used in the 16-day special studies and the 2-year studies consisted of a linear dust feeder, a particle attrition chamber, and an aerosol distribution system (Figure L4). The linear dust feeder, a slide-bar dust-metering device, was composed of a shuttle bar, body, outlet port, and hopper (Figure L5). As the compressed-air-driven shuttle bar slid back and forth during generation, the metering port aligned with the hopper, which served as a reservoir for the bulk chemical, and was filled with a small amount of vanadium pentoxide powder. As the shuttle bar slid to the dispersing position, the metering port aligned with a compressed-air port in the body and a puff of air from this port dispersed the vanadium pentoxide into the particle attrition chamber. Generator output was regulated by adjusting the cadence of the shuttle bar. The particle attrition chamber, designed and fabricated by the study laboratory, used low fluid energy from an air jet tangential to the chamber to deagglomerate the vanadium pentoxide particles. After deagglomeration, the particles were swept into a classification zone where smaller particles exited to the distribution line; larger particles were thrown to the perimeter of the classifier by centrifugal force and were reentrained into the impacting air jet, and the process was repeated until the particles were sufficiently deagglomerated. The aerosol passed through the distribution lines to

the exposure chambers. A pneumatic pump designed by the study laboratory was located at each chamber inlet and drew aerosol from the distribution line into the chamber inlet, where it was diluted with conditioned air to the appropriate concentration. Flow through the distribution line was controlled by Air-Vac pumps (Air-Vac Engineering, Milford, CT), and pressure was monitored by photohelic differential pressure gauges (Dwyer Instruments, Inc., Michigan City, IN).

The stainless-steel inhalation exposure chambers (Harford Systems Division of Lab Products, Inc., Aberdeen, MD) were designed so that uniform aerosol concentrations could be maintained throughout the chambers when catch pans were in place. The total active mixing volume of each chamber was 1.7 m³.

AEROSOL CONCENTRATION MONITORING

Summaries of chamber aerosol concentrations of vanadium pentoxide are given in Tables L1 through L4. During all studies, chamber aerosol concentrations were monitored with real-time aerosol monitors (RAMs) (Model Ram-S, 16-day and 3-month studies; Model Ram-1, 16-day special studies and 2-year studies; MIE, Inc., Bedford, MA) that used a pulsed-light-emitting diode in combination with a silicon detector to sense light scattered over a forward angular range of 45° to 95° by particles traversing the sensing volume. The instruments respond to particles 0.1 to 20 µm in diameter. During the 16-day and 3-month studies, an individual monitor was used for each exposure chamber. The voltage output of the online monitors was read and recorded, and the calibration curve was applied to the voltages measured by the RAM to convert the measured voltages to exposure chamber concentrations. For the 16-day special studies and the 2-year studies, the sampling system consisted of a valve that multiplexed each RAM to two or three exposure chambers and to a HEPA filter and/or the control chamber or room; selection of sampling streams and data acquisition from each RAM was remotely controlled by a computer (Gateway 2000, San Diego, CA). Equations for calibration curves were stored in the computers and were used to convert the measured voltages to exposure concentrations.

Each RAM was calibrated daily during the 16-day and 3-month studies by correlating the measured voltage with vanadium pentoxide concentrations determined by gravimetric analysis of glass fiber filters (Gelman Laboratory, Ann Arbor, MI) and one to two times per week during the 2-year studies by ICP/AES or ICP/mass spectrometry analysis of Pallflex® TX40H120WW glass fiber filters (Pallflex Corp., Putnum, CT). Filters to be analyzed with ICP/AES and ICP/mass spectrometry analyses were dissolved in 2% nitric acid and sonicated. The ICP/AES was calibrated for each filter analysis against a vanadium standard provided by the NIST.

CHAMBER ATMOSPHERE CHARACTERIZATION

The particle size distribution in each chamber was determined prior to the start of all studies, during the first week of the 16-day and 3-month studies, during the first 2 weeks of the 2-year studies, and monthly during the 3-month and 2-year studies. For the 16-day and 3-month studies, a 10-stage Quartz Crystal Microbalance-based cascade impactor (California Measurements, Inc., Sierra Madre, CA) was used to separate the aerosol particles into sequential size ranges; the mass median aerodynamic diameter was calculated from the corresponding mass fraction of particles at each stage. For the 16-day special studies and the 2-year studies, a Mercer-style seven-stage impactor (In-Tox Products, Albuquerque, NM) was used. The stages (glass coverslips lightly sprayed with silicon) were analyzed by ICP/AES, and the relative mass collected on each stage was analyzed by probit analysis. The mass median aerodynamic diameters and the geometric standard deviations are given in Tables L5 through L9.

Buildup and decay rates for chamber aerosol concentrations were determined with and without animals present in the chambers. At a chamber airflow rate of 15 air changes per hour, the theoretical values for the time to achieve 90% of the target concentration after the beginning of vapor generation (T_{90}) and the time for the chamber concentration to decay to 10% of the target concentration after vapor generation was terminated (T_{10}) were approximately 15 minutes (16-day and 3-month studies) and 12.5 minutes (16-day special studies and 2-year studies). For rats and mice in the 16-day studies, T_{90} values ranged from 10 to 12 minutes with animals present and from 6 to 11 minutes without animals in the chambers; the T_{10} value ranged from 11 to 16 minutes with

animals present and was 10 to 13 minutes without animals. For rats and mice in the 3-month studies, T_{90} values ranged from 5 to 17 minutes with animals present and 8 to 12 minutes without animals; T_{10} values ranged from 12 to 16 minutes with animals present; without animals, the T_{10} was 15 to 16 minutes. For rats in the 16-day special studies, the T_{90} value was 10 to 11 minutes without animals present and 13 to 16 minutes with animals; the T_{10} value was 9 minutes without animals present and 9 to 10 minutes with animals. For mice, the T_{90} value was 11 to 12 minutes without animals and ranged from 12 to 16 minutes with animals; the T_{10} was 9 to 10 minutes with and without animals. For rats in the 2-year studies, the T_{90} value ranged from 10 to 13 minutes without animals present and from 7 to 11 minutes with animals; the T_{10} value was 9 minutes without animals present and was 8 to 12 minutes with animals. For mice, the T_{90} value was 10 to 13 minutes without animals and was 8 to 10 minutes with animals; the T_{10} value was 9 to 10 minutes without animals and 13 minutes with animals. A T_{90} value of 15 minutes (16-day and 13-month studies) or 12 minutes (16-day special studies and 2-year studies) was selected for each study.

The uniformity of aerosol concentration in the inhalation exposure chambers without animals was evaluated before each of the studies began; concentration uniformity with animals present in the chambers was also measured once during the 16-day studies, the 3-month studies, and the 16-day special studies and every 3 months during the 2-year studies. RAM measurements were taken from 8 (16-day and 3-month studies) or 12 (16-day special studies and 2-year studies) different chamber positions. During the 16-day and 3-month studies, minor excursions in chamber uniformity values (between-port and within-port variability) were observed in one or more exposure chambers, but these excursions had no impact on the studies. Chamber concentration uniformity was acceptable throughout the 16-day special studies and 2-year studies.

The persistence of vanadium pentoxide in the exposure chambers was monitored overnight after aerosol delivery ceased. The 32 and 16 mg/m³ exposure chambers were monitored with and without animals present during the 16-day and 3-month studies, respectively; in these studies, the chamber atmospheres were tested after a 15-minute service period in which the doors to the chambers were open. The 8 mg/m³ mouse exposure chamber was monitored with animals present during the 16-day special studies. For the 2-year studies, the 4 mg/m³ exposure chamber (without animals present) was monitored during prestudy testing, and a 2 mg/m³ rat exposure chamber and a 4 mg/m³ mouse exposure chamber were monitored during exposure with animals present. During the 16-day and 3-month studies, no vanadium pentoxide was detected in the chambers by the RAMs immediately after the service period; this was confirmed by gravimetric samples collected and analyzed 2 hours after the initial analysis. During the 16-day special studies, the average vanadium pentoxide concentration decayed to 1% of the target concentration within 20 minutes. During the 2-year studies, the average vanadium pentoxide concentration decayed to 1% of the target concentration within approximately 20 minutes during prestudy testing and within approximately 16 (2 mg/m³ rat exposure chamber) or 20 (4 mg/m³ mouse exposure chamber) minutes with animals present in the chambers.

The stability of vanadium pentoxide in the generator reservoir, distribution line, 2 and 32 mg/m³ chambers (16-day studies), 2 and 16 mg/m³ chambers (3-month studies), 1 and 8 mg/m³ chambers without animals (16-day special studies), and 0.5 (rat) and 4 (mouse) mg/m³ chambers with animals present (2-year studies) was tested with XRD analysis. The samples were analyzed along with samples of the bulk chemical. The samples were collected from the generator reservoir at the beginning and end (16-day studies only) of the studies. For the 16-day and 3-month studies, samples from the distribution lines and exposure chambers were collected on silver membrane filters (Hytrex Filters Division, Osmonics, Inc., Minnetonka, MN); samples from the generator were prepared on silver filters as deposits from isopropyl alcohol suspension. For the 16-day special studies and 2-year studies, XRD analyses indicated no detectable buildup of degradation products in the distribution line, exposure chamber, or generator reservoir at a detection limit of approximately 1%. In addition, filter samples collected from the exposure chambers, generator reservoir, and distribution line during the 16-day special studies and the 2-year studies were analyzed by ICP/AES. Bulk and generator reservoir samples were dissolved in 2% nitric acid. Samples from the distribution line and exposure chambers were collected on Pallflex[®] quartz fiber filters and dissolved with 10% nitric acid and sonicated in a heated water bath; the extracts were diluted in 2% nitric acid.

Yttrium solution was added to all ICP/AES samples as an internal standard. During the 16-day special studies, copper was detected in generator reservoir samples at a concentration of 0.11% during prestudy testing; the total concentration of trace elements present was less than 0.2% in the distribution lines and exposure chambers and less than 0.3% in the generator reservoirs. All other impurities were present at a total concentration of less than 0.03% in all samples. During the 2-year studies, no impurities with concentrations greater than 0.1% were found in the bulk chemical, in the generator reservoir, or in the 4 mg/m³ chamber. During the first weeks of the 2-year studies, aluminum was detected in the distribution line samples (approximately 0.18%) and the 0.5 mg/m³ chamber sample (approximately 1.6%); no other impurities with concentrations greater than 0.1% were detected in these samples. Aluminum may have been introduced into the test material as a result of abrasion of the aluminum generator reservoir by moving parts. A slide bar was realigned, and after approximately 2 weeks, additional samples were collected and analyzed for the presence of aluminum. The concentrations of aluminum determined in the generator reservoir, distribution line, and chamber samples were less than 0.03%.

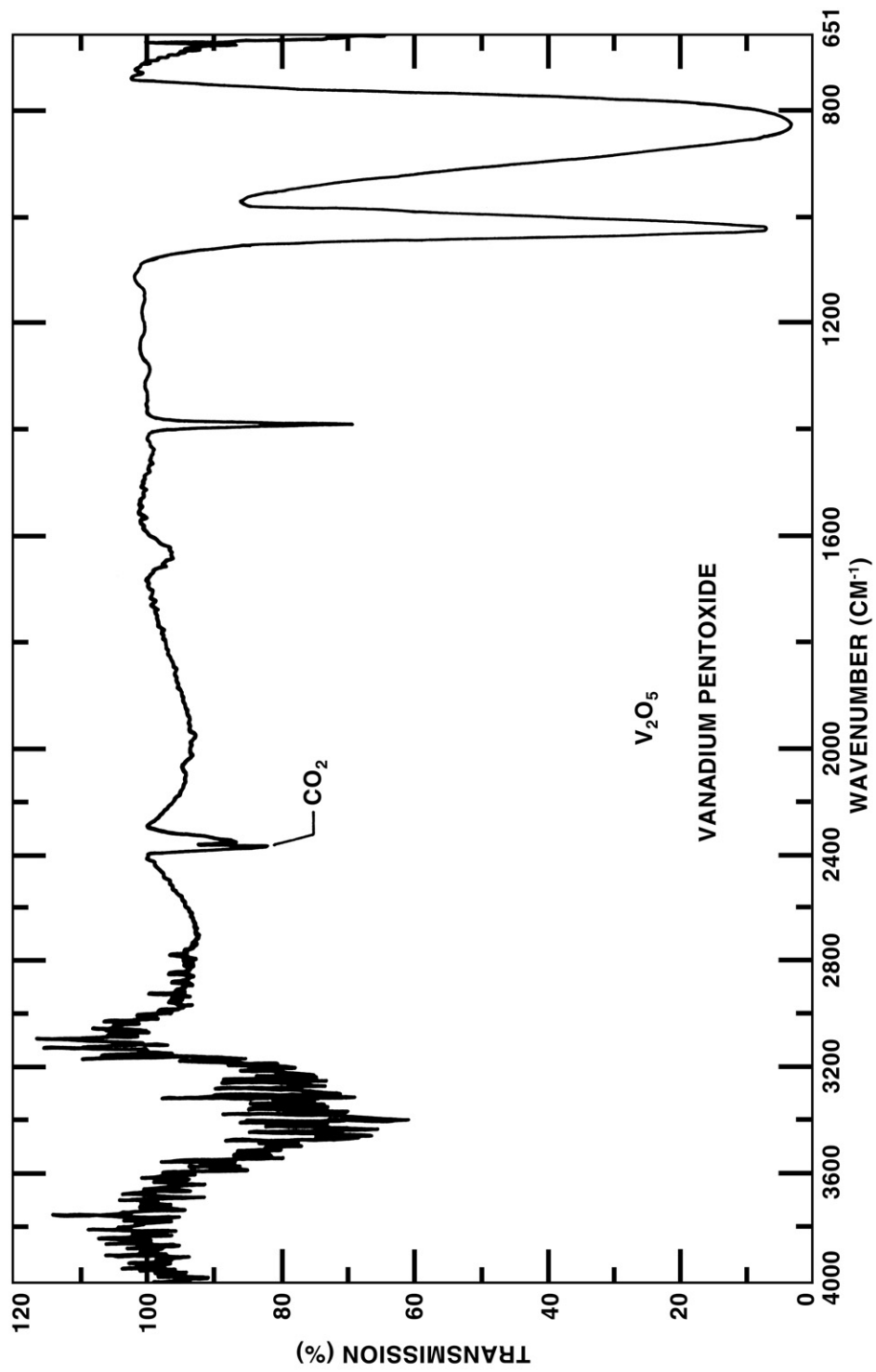

FIGURE L1
Infrared Absorption Spectrum of Vanadium Pentoxide

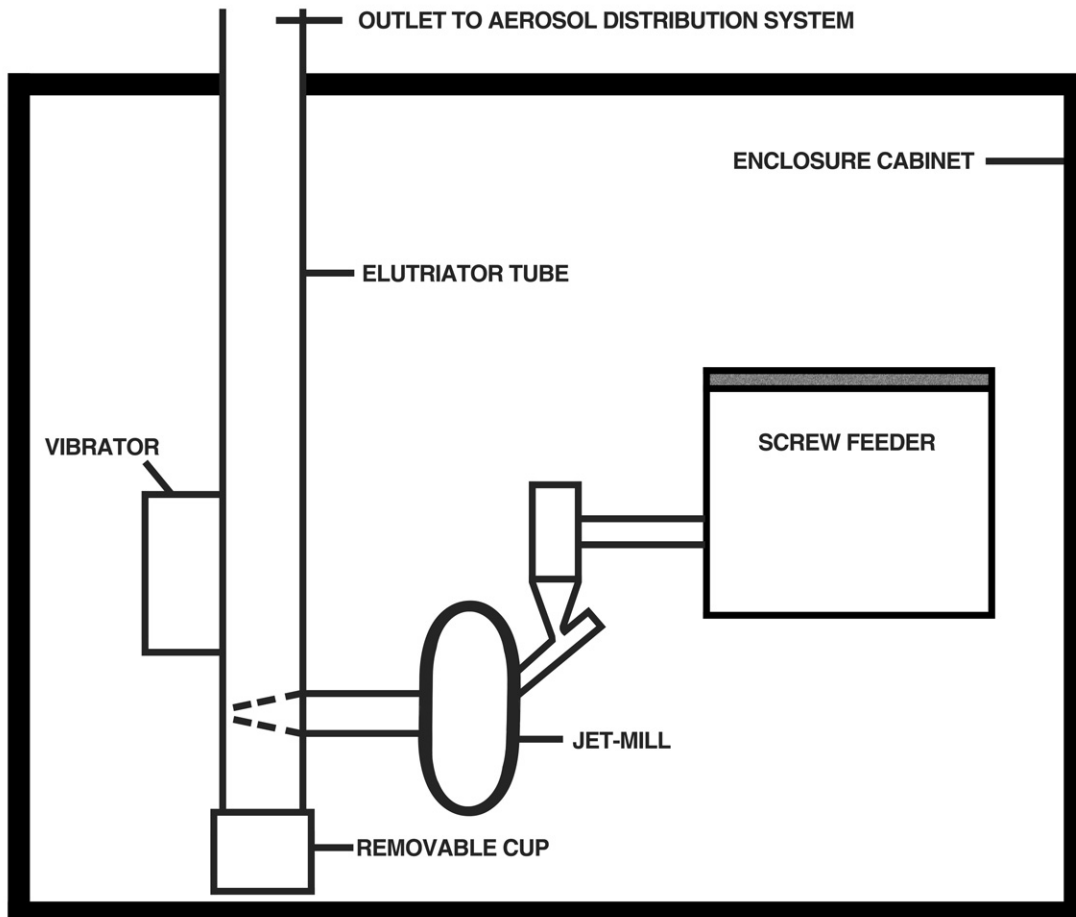

FIGURE L2
Schematic of the Aerosol Generation System in the 16-Day
and 3-Month Inhalation Studies of Vanadium Pentoxide

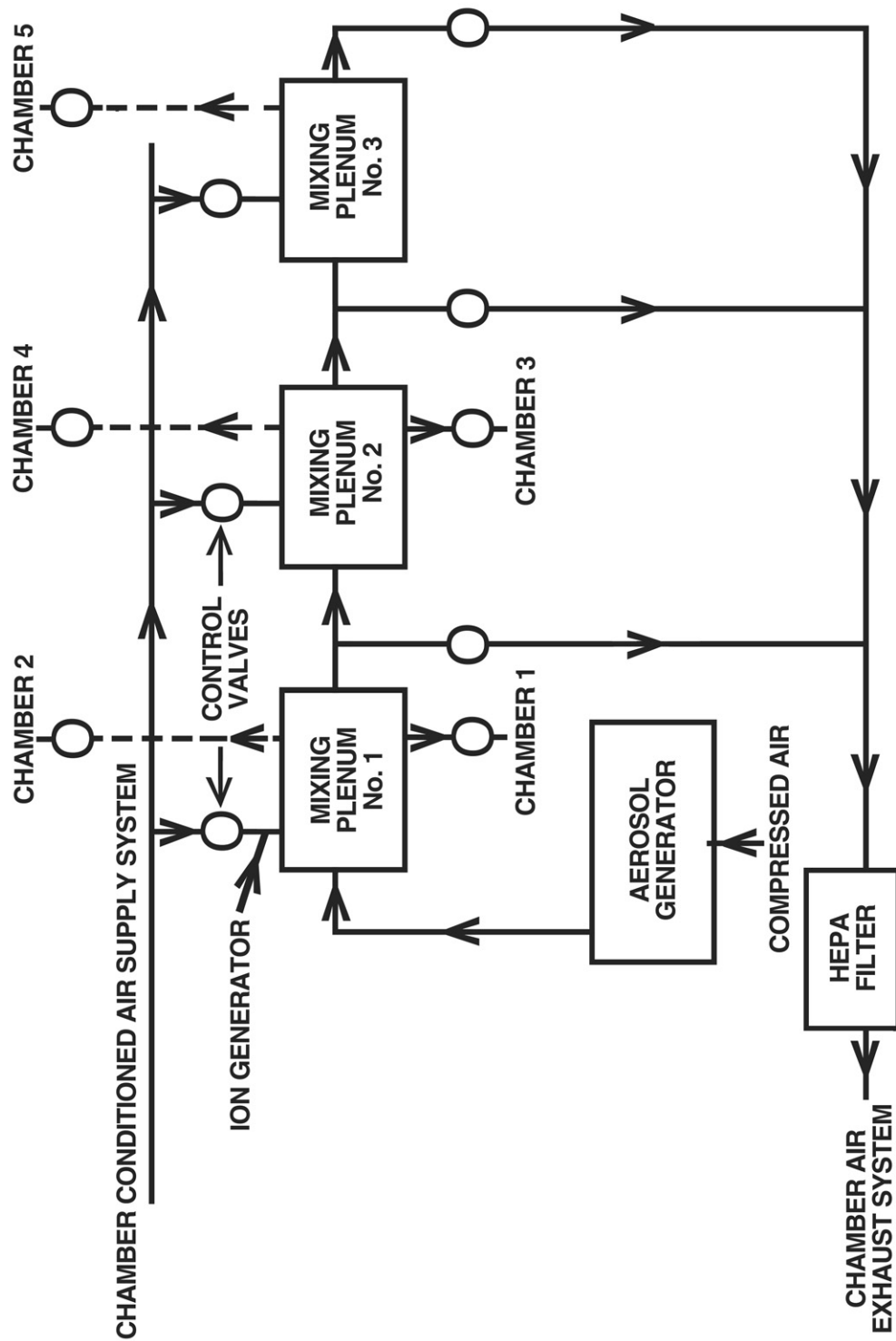

FIGURE L3
 Schematic of the Aerosol Delivery System in the 16-Day and 3-Month Inhalation Studies of Vanadium Pentoxide

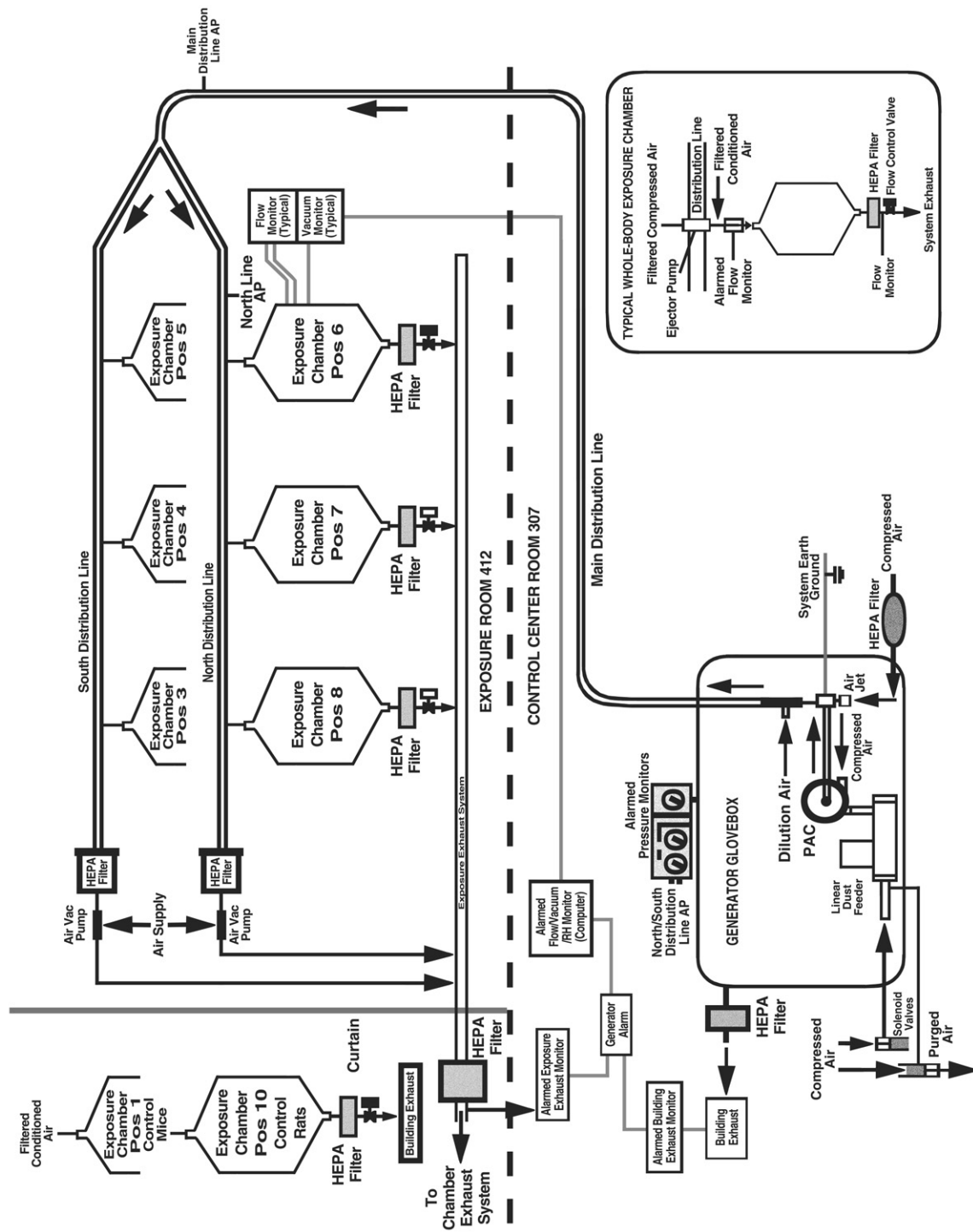

FIGURE L4
Schematic of the Aerosol Generation and Delivery System in the 16-Day Special Studies and 2-Year Inhalation Studies of Vanadium Pentoxide

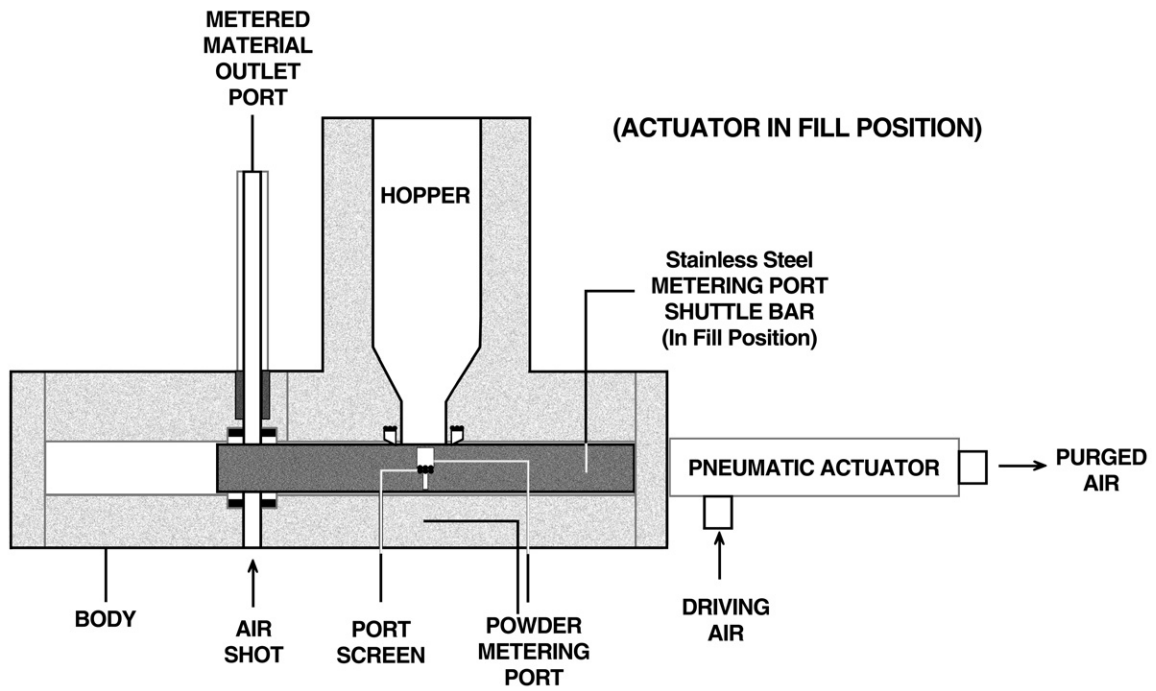

FIGURE L5
Schematic of the Linear Dust Feeder in the 16-Day Special Studies
and 2-Year Inhalation Studies of Vanadium Pentoxide

TABLE L1
Summary of Chamber Concentrations in the 16-Day Inhalation Studies of Vanadium Pentoxide

Target Concentration (mg/m ³)	Total Number of Readings	Average Concentration ^a (mg/m ³)
Rat Chambers		
2	72	1.8 ± 0.1
4	72	4.2 ± 0.2
8	72	8.1 ± 0.5
16	72	16.1 ± 0.4
32	73	31.9 ± 1.8
Mouse Chambers		
2	78	1.8 ± 0.1
4	78	4.2 ± 0.2
8	78	8.2 ± 0.6
16	78	16.1 ± 0.4
32	79	31.9 ± 1.8

^a Mean ± standard deviation

TABLE L2
Summary of Chamber Concentrations in the 3-Month Inhalation Studies of Vanadium Pentoxide

Target Concentration (mg/m ³)	Total Number of Readings	Average Concentration ^a (mg/m ³)
Rat Chambers		
1	776	1.0 ± 0.0
2	776	2.0 ± 0.0
4	776	4.0 ± 0.1
8	775	7.9 ± 0.2
16	776	15.9 ± 0.4
Mouse Chambers		
1	777	1.0 ± 0.0
2	777	2.0 ± 0.0
4	777	4.0 ± 0.1
8	776	7.9 ± 0.2
16	777	15.9 ± 0.4

^a Mean ± standard deviation

TABLE L3
Summary of Chamber Concentrations in the 16-Day Special Studies of Vanadium Pentoxide

Target Concentration (mg/m ³)	Total Number of Readings	Average Concentration ^a (mg/m ³)
Rat Chambers		
1	118	1.00 ± 0.05
2	117	2.02 ± 0.10
4	118	4.07 ± 0.19
Mouse Chambers		
2	117	2.03 ± 0.15
4	117	4.03 ± 0.27
8	119	8.05 ± 0.38

^a Mean ± standard deviation

TABLE L4
Summary of Chamber Concentrations in the 2-Year Inhalation Studies of Vanadium Pentoxide

Target Concentration (mg/m ³)	Total Number of Readings	Average Concentration ^a (mg/m ³)
Rat Chambers		
0.5	4,885	0.50 ± 0.05
1	4,853	1.00 ± 0.08
2	4,877	2.02 ± 0.16
Mouse Chambers		
1	4,850	1.00 ± 0.08
2	4,855	2.02 ± 0.14
4	4,890	4.05 ± 0.34

^a Mean ± standard deviation

TABLE L5
Summary of Aerosol Size Measurements for the Rat and Mouse Exposure Chambers
in the 16-Day Inhalation Studies of Vanadium Pentoxide^a

2 mg/m³		4 mg/m³		8 mg/m³		16 mg/m³		32 mg/m³	
MMAD	GSD	MMAD	GSD	MMAD	GSD	MMAD	GSD	MMAD	GSD
(μm)		(μm)		(μm)		(μm)		(μm)	
1.0	2.7	1.2	2.8	1.3	2.4	1.2	2.3	1.2	2.3

^a MMAD=mass median aerodynamic diameter; GSD=geometric standard deviation

TABLE L6
Summary of Aerosol Size Measurements for the Rat and Mouse Exposure Chambers
in the 3-Month Inhalation Studies of Vanadium Pentoxide^a

	1 mg/m³		2 mg/m³		4 mg/m³		8 mg/m³		16 mg/m³	
	MMAD	GSD	MMAD	GSD	MMAD	GSD	MMAD	GSD	MMAD	GSD
	(μm)		(μm)		(μm)		(μm)		(μm)	
September 1990	1.2	2.3	1.2	2.8	1.3	2.9	1.0	2.4	1.3	2.4
October 1990	1.2	3.0	1.0	2.7	1.0	2.7	1.0	2.6	1.1	2.4
November 1990	1.2	3.0	1.1	3.0	1.3	3.0	1.0	2.2	1.3	2.2
December 1990	1.2	3.0	1.1	2.9	1.2	2.8	1.1	2.1	1.0	2.1

^a MMAD=mass median aerodynamic diameter; GSD=geometric standard deviation

TABLE L7
Summary of Aerosol Size Measurements for the Rat and Mouse Exposure Chambers
in the 16-Day Special Studies of Vanadium Pentoxide^a

	1 mg/m³		2 mg/m³		4 mg/m³		8 mg/m³	
	MMAD	GSD	MMAD	GSD	MMAD	GSD	MMAD	GSD
	(μm)		(μm)		(μm)		(μm)	
Rat Chambers	1.2	1.9	1.3	1.5	1.3	1.8	— ^b	—
Mouse Chambers	—	—	1.1	1.9	1.2	1.8	1.2	1.8

^a MMAD=mass median aerodynamic diameter; GSD=geometric standard deviation

^b Not tested at this exposure concentration

TABLE L8
Summary of Aerosol Size Measurements for the Rat Exposure Chambers
in the 2-Year Inhalation Study of Vanadium Pentoxide^a

	0.5 mg/m ³		1 mg/m ³		2 mg/m ³	
	MMAD (μ m)	GSD	MMAD (μ m)	GSD	MMAD (μ m)	GSD
December 1996	1.1	1.9	1.2	1.8	1.1	1.9
January 1997	1.0	1.9	1.3	1.9	1.3	1.8
February 1997	1.1	1.9	1.0	1.9	1.1	1.8
March 1997	1.2	2.0	1.2	2.0	1.2	1.9
April 1997	1.2	2.0	1.2	1.9	1.2	1.9
May 1997	1.4	1.9	1.4	1.9	1.5	1.9
June 1997	1.3	1.9	1.6	1.9	1.4	1.8
July 1997	1.3	2.0	1.5	1.9	1.5	1.9
August 1997	1.2	1.9	1.3	1.8	1.4	1.9
September 1997	1.3	2.0	1.2	1.9	1.1	1.9
October 1997	1.2	1.9	1.2	1.9	1.3	1.8
November 1997	1.2	1.9	1.2	1.9	1.3	1.8
December 1997	1.3	2.0	1.2	1.9	1.3	1.9
January 1998	1.3	2.0	1.2	1.9	1.2	1.9
February 1998	1.3	1.9	1.2	1.9	1.2	1.8
March 1998	1.3	2.0	1.2	1.9	1.2	1.9
April 1998	1.2	1.9	1.3	1.9	1.2	1.9
May 1998	1.3	1.9	1.2	1.9	1.3	1.8
June 1998	1.2	1.9	1.2	1.9	1.3	1.8
July 1998	1.2	1.9	1.2	1.9	1.2	1.8
August 1998	1.1	1.9	1.2	1.9	1.2	1.8
September 1998	1.2	1.9	1.2	1.9	1.3	1.8
October 1998	1.2	1.9	1.1	1.9	1.1	1.8
November 1998	1.3	1.9	1.2	1.9	1.2	1.9
December 1998	1.2	1.9	1.2	1.9	1.3	1.9
Mean \pm standard deviation	1.2 \pm 0.1	1.9 \pm 0.0	1.2 \pm 0.1	1.9 \pm 0.0	1.3 \pm 0.1	1.9 \pm 0.1

^a MMAD=mass median aerodynamic diameter; GSD=geometric standard deviation

TABLE L9
Summary of Aerosol Size Measurements for the Mouse Exposure Chambers
in the 2-Year Inhalation Study of Vanadium Pentoxide^a

	1 mg/m ³		2 mg/m ³		4 mg/m ³	
	MMAD (μ m)	GSD	MMAD (μ m)	GSD	MMAD (μ m)	GSD
December 1996	1.2	1.9	1.1	1.9	1.2	1.8
January 1997	1.2	1.9	1.1	1.8	1.1	1.9
February 1997	1.2	1.9	1.2	1.8	1.2	1.9
March 1997	1.2	1.9	1.2	1.8	1.2	1.9
April 1997	1.2	1.9	1.2	1.9	1.1	1.9
May 1997	1.4	1.8	1.4	1.9	1.4	1.9
June 1997	1.3	1.8	1.4	2.0	1.5	1.9
July 1997	1.4	1.8	1.3	1.8	1.3	1.9
August 1997	1.2	1.9	1.2	1.8	1.2	1.8
September 1997	1.3	1.9	1.3	1.9	1.2	1.8
October 1997	1.3	1.9	1.2	1.9	1.2	1.9
November 1997	1.3	1.9	1.3	1.9	1.3	1.8
December 1997	1.3	1.9	1.3	1.8	1.3	1.8
January 1998	1.4	1.9	1.3	1.9	1.3	1.9
February 1998	1.4	2.0	1.3	1.9	1.3	1.9
March 1998	1.3	1.8	1.3	1.8	1.3	1.8
April 1998	1.3	1.8	1.3	1.8	1.2	2.0
May 1998	1.3	1.8	1.2	1.9	1.2	1.9
June 1998	1.3	1.8	1.1	1.9	1.3	1.8
July 1998	1.2	1.8	1.3	1.9	1.2	1.8
August 1998	1.3	1.9	1.3	1.9	1.3	1.9
September 1998	1.2	1.9	1.2	1.9	1.2	1.8
October 1998	1.3	1.8	1.2	1.8	1.2	1.8
November 1998	1.3	1.9	1.2	1.9	1.2	1.9
December 1998	1.3	1.9	1.2	1.8	1.2	1.9
Mean \pm standard deviation	1.3 \pm 0.1	1.9 \pm 0.1	1.2 \pm 0.1	1.9 \pm 0.1	1.2 \pm 0.1	1.9 \pm 0.1

^a MMAD=mass median aerodynamic diameter; GSD=geometric standard deviation

APPENDIX M
INGREDIENTS, NUTRIENT COMPOSITION,
AND CONTAMINANT LEVELS
IN NTP-2000 RAT AND MOUSE RATION

TABLE M1	Ingredients of NTP-2000 Rat and Mouse Ration	330
TABLE M2	Vitamins and Minerals in NTP-2000 Rat and Mouse Ration	330
TABLE M3	Nutrient Composition of NTP-2000 Rat and Mouse Ration	331
TABLE M4	Contaminant Levels in NTP-2000 Rat and Mouse Ration	332

TABLE M1
Ingredients of NTP-2000 Rat and Mouse Ration

Ingredients	Percent by Weight
Ground hard winter wheat	22.26
Ground #2 yellow shelled corn	22.18
Wheat middlings	15.0
Oat hulls	8.5
Alfalfa meal (dehydrated, 17% protein)	7.5
Purified cellulose	5.5
Soybean meal (49% protein)	5.0
Fish meal (60% protein)	4.0
Corn oil (without preservatives)	3.0
Soy oil (without preservatives)	3.0
Dried brewer's yeast	1.0
Calcium carbonate (USP)	0.9
Vitamin premix ^a	0.5
Mineral premix ^b	0.5
Calcium phosphate, dibasic (USP)	0.4
Sodium chloride	0.3
Choline chloride (70% choline)	0.26
Methionine	0.2

^a Wheat middlings as carrier

^b Calcium carbonate as carrier

TABLE M2
Vitamins and Minerals in NTP-2000 Rat and Mouse Ration^a

	Amount	Source
Vitamins		
A	4,000 IU	Stabilized vitamin A palmitate or acetate
D	1,000 IU	D-activated animal sterol
K	1.0 mg	Menadione sodium bisulfite complex
α-Tocopheryl acetate	100 IU	
Niacin	23 mg	
Folic acid	1.1 mg	
<i>d</i> -Pantothenic acid	10 mg	<i>d</i> -Calcium pantothenate
Riboflavin	3.3 mg	
Thiamine	4 mg	Thiamine mononitrate
B ₁₂	52 μg	
Pyridoxine	6.3 mg	Pyridoxine hydrochloride
Biotin	0.2 mg	<i>d</i> -Biotin
Minerals		
Magnesium	514 mg	Magnesium oxide
Iron	35 mg	Iron sulfate
Zinc	12 mg	Zinc oxide
Manganese	10 mg	Manganese oxide
Copper	2.0 mg	Copper sulfate
Iodine	0.2 mg	Calcium iodate
Chromium	0.2 mg	Chromium acetate

^a Per kg of finished product

TABLE M3
Nutrient Composition of NTP-2000 Rat and Mouse Ration

Nutrient	Mean ± Standard Deviation	Range	Number of Samples
Protein (% by weight)	13.2 ± 0.49	12.5 – 14.2	23
Crude fat (% by weight)	8.1 ± 0.27	7.6 – 8.6	23
Crude fiber (% by weight)	9.5 ± 0.54	8.3 – 10.3	23
Ash (% by weight)	5.0 ± 0.15	4.7 – 5.3	23
Amino Acids (% of total diet)			
Arginine	0.731 ± 0.050	0.670 – 0.800	8
Cystine	0.224 ± 0.012	0.210 – 0.240	8
Glycine	0.684 ± 0.041	0.620 – 0.740	8
Histidine	0.333 ± 0.018	0.310 – 0.350	8
Isoleucine	0.524 ± 0.046	0.430 – 0.590	8
Leucine	1.061 ± 0.061	0.960 – 1.130	8
Lysine	0.708 ± 0.056	0.620 – 0.790	8
Methionine	0.401 ± 0.035	0.350 – 0.460	8
Phenylalanine	0.598 ± 0.036	0.540 – 0.640	8
Threonine	0.501 ± 0.051	0.430 – 0.590	8
Tryptophan	0.126 ± 0.014	0.110 – 0.150	8
Tyrosine	0.390 ± 0.056	0.280 – 0.460	8
Valine	0.640 ± 0.049	0.550 – 0.690	8
Essential Fatty Acids (% of total diet)			
Linoleic	3.97 ± 0.284	3.59 – 4.54	8
Linolenic	0.30 ± 0.042	0.21 – 0.35	8
Vitamins			
Vitamin A (IU/kg)	5,037 ± 1,144	3,280 – 7,420	23
Vitamin D (IU/kg)	1,000 ^a		
α-Tocopherol (ppm)	82.2 ± 14.08	62.2 – 107.0	8
Thiamine (ppm) ^b	7.42 ± 0.95	6.0 – 9.3	23
Riboflavin (ppm)	5.6 ± 1.12	4.20 – 7.70	8
Niacin (ppm)	74.3 ± 5.94	66.4 – 85.8	8
Pantothenic acid (ppm)	22.5 ± 3.96	17.4 – 29.1	8
Pyridoxine (ppm) ^b	9.04 ± 2.37	6.4 – 12.4	8
Folic acid (ppm)	1.64 ± 0.38	1.26 – 2.32	8
Biotin (ppm)	0.333 ± 0.15	0.225 – 0.704	8
Vitamin B ₁₂ (ppb)	68.7 ± 63.0	18.3 – 174.0	8
Choline (as chloride) (ppm)	3,155 ± 325	2,700 – 3,790	8
Minerals			
Calcium (%)	0.965 ± 0.035	0.905 – 1.050	23
Phosphorus (%)	0.549 ± 0.025	0.498 – 0.600	23
Potassium (%)	0.659 ± 0.022	0.627 – 0.691	8
Chloride (%)	0.357 ± 0.027	0.300 – 0.392	8
Sodium (%)	0.189 ± 0.019	0.160 – 0.212	8
Magnesium (%)	0.199 ± 0.009	0.185 – 0.213	8
Sulfur (%)	0.178 ± 0.021	0.153 – 0.209	8
Iron (ppm)	160 ± 14.7	135 – 177	8
Manganese (ppm)	50.3 ± 4.82	42.1 – 56.0	8
Zinc (ppm)	50.7 ± 6.59	43.3 – 61.1	8
Copper (ppm)	6.29 ± 0.828	5.08 – 7.59	8
Iodine (ppm)	0.461 ± 0.187	0.233 – 0.843	8
Chromium (ppm)	0.542 ± 0.128	0.330 – 0.707	7
Cobalt (ppm)	0.23 ± 0.049	0.20 – 0.30	7

^a From formulation

^b As hydrochloride

TABLE M4
Contaminant Levels in NTP-2000 Rat and Mouse Ration^a

	Mean ± Standard Deviation ^b	Range	Number of Samples
Contaminants			
Arsenic (ppm)	0.23 ± 0.143	0.10 – 0.50	23
Cadmium (ppm)	0.04 ± 0.013	0.04 – 0.10	23
Lead (ppm)	0.08 ± 0.022	0.06 – 0.16	23
Mercury (ppm)	<0.02		23
Selenium (ppm)	0.16 ± 0.029	0.11 – 0.23	23
Aflatoxins (ppb)	<5.00		23
Nitrate nitrogen (ppm) ^c	16.4 ± 8.10	9.04 – 39.6	23
Nitrite nitrogen (ppm) ^c	<0.61		23
BHA (ppm) ^d	1.1 ± 0.38	1.0 – 2.5	23
BHT (ppm) ^d	1.0 ± 0.14	1.0 – 1.7	23
Aerobic plate count (CFU/g)	10 ± 1.0	10 – 15	23
Coliform (MPN/g)	0.1 ± 0.6	0 – 3	23
<i>Escherichia coli</i> (MPN/g)	<10		23
<i>Salmonella</i> (MPN/g)	Negative		23
Total nitrosoamines (ppb) ^e	5.7 ± 3.78	2.1 – 20.9	23
<i>N</i> -Nitrosodimethylamine (ppb) ^e	2.1 ± 1.33	1.1 – 6.4	23
<i>N</i> -Nitrosopyrrolidine (ppb) ^e	3.6 ± 2.73	1.0 – 14.5	23
Pesticides (ppm)			
α-BHC	<0.01		23
β-BHC	<0.02		23
γ-BHC	<0.01		23
δ-BHC	<0.01		23
Heptachlor	<0.01		23
Aldrin	<0.01		23
Heptachlor epoxide	<0.01		23
DDE	<0.01		23
DDD	<0.01		23
DDT	<0.01		23
HCB	<0.01		23
Mirex	<0.01		23
Methoxychlor	<0.05		23
Dieldrin	<0.01		23
Endrin	<0.01		23
Telodrin	<0.01		23
Chlordane	<0.05		23
Toxaphene	<0.10		23
Estimated PCBs	<0.20		23
Ronnel	<0.01		23
Ethion	<0.02		23
Trithion	<0.05		23
Diazinon	<0.10		23
Methyl chlorpyrifos	0.087 ± 0.067	0.020 – 0.253	23
Methyl parathion	<0.02		23
Ethyl parathion	<0.02		23
Malathion	0.164 ± 0.168	0.020 – 0.731	23
Endosulfan I	<0.01		23
Endosulfan II	<0.01		23
Endosulfan sulfate	<0.03		23

^a All samples were irradiated. CFU=colony-forming units; MPN=most probable number; BHC=hexachlorocyclohexane or benzene hexachloride

^b For values less than the limit of detection, the detection limit is given as the mean.

^c Sources of contamination: alfalfa, grains, and fish meal

^d Sources of contamination: soy oil and fish meal

^e All values were corrected for percent recovery.

APPENDIX N

SENTINEL ANIMAL PROGRAM

METHODS	334
RESULTS	336

SENTINEL ANIMAL PROGRAM

METHODS

Rodents used in the Carcinogenesis Program of the National Toxicology Program are produced in optimally clean facilities to eliminate potential pathogens that may affect study results. The Sentinel Animal Program is part of the periodic monitoring of animal health that occurs during the toxicologic evaluation of chemical compounds. Under this program, the disease state of the rodents is monitored via serology on sera from extra (sentinel) animals in the study rooms. These animals and the study animals are subject to identical environmental conditions. The sentinel animals come from the same production source and weanling groups as the animals used for the studies of chemical compounds.

Serum samples were collected from randomly selected rats and mice during the 3-month and 2-year studies. Blood from each animal was collected and allowed to clot, and the serum was separated. The samples were processed appropriately and sent to BioReliance. (Bethesda, MD), for determination of antibody titers. The laboratory serology methods and viral agents for which testing was performed are tabulated below; the times at which blood was collected during the studies are also listed. At 18 months, live mice were shipped to MA Bioservices (Rockville, MD) for evaluation of viral serology and bacterial profile including *Helicobacter hepaticus* according to NIEHS Advisory Number 19.

<u>Method and Test</u>	<u>Time of Analysis</u>
RATS	
3-Month Study	
ELISA	
PVM (pneumonia virus of mice)	Study termination
RCV/SDA (rat coronavirus/sialodacryoadenitis virus)	Study termination
Sendai	Study termination
Immunofluorescence Assay	
Parvovirus	Study termination
Rat cytomegalovirus	Study termination
Hemagglutination Inhibition	
H-1 (Toolan's H-1 virus)	Study termination
KRV (Kilham rat virus)	Study termination
2-Year Study	
ELISA	
<i>Mycoplasma arthritis</i>	Study termination
<i>Mycoplasma pulmonis</i>	Study termination
PVM	6, 12, and 18 months, study termination
RCV/SDA	6, 12, and 18 months, study termination
Sendai	6, 12, and 18 months, study termination
Immunofluorescence Assay	
<i>M. arthritis</i>	Study termination
Parvovirus	12 and 18 months, study termination
PVM	12 and 18 months, study termination
Hemagglutination Inhibition	
H-1	6 months
KRV	6 months

Method and Test**Time of Analysis****MICE****3-Month Study**

ELISA

Ectromelia virus	Study termination
GDVII (mouse encephalomyelitis virus)	Study termination
LCM (lymphocytic choriomeningitis virus)	Study termination
Mouse adenoma virus-FL	Study termination
MHV (mouse hepatitis virus)	Study termination
PVM	Study termination
Reovirus 3	Study termination
Sendai	Study termination

Immunofluorescence Assay

EDIM (epizootic diarrhea of infant mice)	Study termination
Reovirus 3	Study termination

Hemagglutination Inhibition

K (papovavirus)	Study termination
MVM (minute virus of mice)	Study termination
Polyoma virus	Study termination

2-Year Study

Bacterial Assays

Oral	18 months
Fecal	18 months

ELISA

Ectromelia virus	6, 12, and 18 months, study termination
EDIM	6, 12, and 18 months, study termination
GDVII	6, 12, and 18 months, study termination
<i>Helicobacter hepaticus</i>	18 months
LCM	6, 12, and 18 months, study termination
Mouse adenoma virus	6, 12, and 18 months, study termination
MHV	6, 12, and 18 months, study termination
<i>M. arthritidis</i>	18 months, study termination
<i>M. pulmonis</i>	18 months, study termination
PVM	6, 12, 18, and study termination
Reovirus 3	6, 12, 18, and study termination
Sendai	6, 12, 18, and study termination

Immunofluorescence Assay

GDVII	12 and 18 months
LCM	18 months
Mouse adenoma virus	12 months, study termination
MCMV (murine cytomegalovirus)	18 months, study termination
<i>M. arthritidis</i>	18 months, study termination
PVM	12 months, study termination
Parvovirus	12 and 18 months, study termination
Reovirus 3	18 months
Sendai	12 months

Method and Test**Time of Analysis****MICE** (continued)**2-Year Study** (continued)

Hemagglutination Inhibition

K	6 months
MVM	6 months
Polyoma virus	6 months

RESULTS

All test results for rats and mice in the 3-month studies were negative. For the 2-year study in rats, all serology tests were negative. Bacterial profiles at 18 months indicated *Pseudomonas aeruginosa* in 3 of 10 mice and *Klebsiella pneumoniae* in one mouse. These findings had no impact on the study results.

APPENDIX O

MOLECULAR ONCOLOGY STUDIES

High frequency of *K-ras* Mutations and Loss of Heterozygosity on Chromosome 6 in Alveolar/Bronchiolar Carcinomas from B6C3F₁ Mice Exposed to Vanadium Pentoxide for 2 Years

Theodora R. Devereux, Wanda Holliday, Joseph H. Roycroft, Nancy B. Ress, and Robert C. Sills

National Institute of Environmental Health Sciences
Research Triangle Park, North Carolina

INTRODUCTION		338
MATERIALS AND METHODS		338
RESULTS		340
DISCUSSION		340
REFERENCES		341
TABLE O1	Mutations of <i>K-ras</i> in Alveolar/bronchiolar Carcinomas from B6C3F₁ Mice in the 2-Year Inhalation Study of Vanadium Pentoxide	343
TABLE O2	Mutations/Loss of Heterozygosity on Chromosome 6 in the Region of <i>K-ras</i> in Alveolar/bronchiolar Carcinomas from B6C3F₁ Mice in the 2-year Inhalation Study of Vanadium Pentoxide	343

MOLECULAR ONCOLOGY STUDIES

High frequency of *K-ras* Mutations and Loss of Heterozygosity on Chromosome 6 in Alveolar/Bronchiolar Carcinomas from B6C3F₁ Mice Exposed to Vanadium Pentoxide for 2 Years

INTRODUCTION

Following exposure of male and female B6C3F₁ mice by inhalation to 1, 2, or 4 mg/m³ vanadium pentoxide for 2 years, there were increased incidences of lung neoplasms and lung inflammation in males and females. Evidence from other studies indicates that oxidative damage likely plays a role in the toxic and carcinogenic response to vanadium pentoxide exposure in rodents (Bonner *et al.*, 2000; Wang and Bonner, 2000).

Analyses of genetic alterations in protooncogenes such as *K-ras* and tumor suppressor genes such as *p53* or *p16-INK4a* provide additional information to help distinguish spontaneous neoplasms from those that occur due to chemical exposure. The frequency of *K-ras* mutations is often greater in lung neoplasms from treated mice than from control animals, and the pattern of mutations is sometimes chemical specific and can provide clues about the mechanisms of chemical action. For example, lung neoplasms in B6C3F₁ mice exposed to ozone or chloroprene had high frequencies (73% and 80%, respectively) of *K-ras* mutations with chemical-specific profiles of mutations (Sills *et al.*, 1995, 1999a). The high proportion of codon 61 A to T transversion mutations identified in the chloroprene lung neoplasms is consistent with formation of adenine adducts by chloroprene metabolites, while in the ozone study, the A to T transversions may have been due to adduct formation or depurination. These molecular findings added to the understanding of the carcinogenicity of the two compounds.

Other molecular alterations that appear to play a role in the induction of lung neoplasia in humans and mice are the loss of *p16-INK4a* (Shapiro *et al.*, 1995; Patel *et al.*, 2000) and, to a lesser extent in mice than humans, *p53* tumor suppressor genes (Hegi *et al.*, 1993). However, loss of function of these tumor suppressor genes seems to occur during the later stages of mouse lung carcinogenesis, and, if it occurs, may not be related to chemical treatment.

In the present study, 40 alveolar/bronchiolar carcinomas from B6C3F₁ mice exposed to vanadium pentoxide for 2 years were examined for mutations in exons 1 and 2 of *K-ras*, for overexpression of mutant *p53* protein using immunohistochemistry, and for loss of heterozygosity on chromosome 6 in the region of *K-ras*. Other studies to assess changes in the *K-ras*/MAP kinase signaling pathway are in progress.

MATERIALS AND METHODS

Lung neoplasms: Male and female B6C3F₁ mice were exposed to 0, 1, 2, or 4 mg/m³ vanadium pentoxide by inhalation, 6 hours per day, 5 days per week, for 2 years. At necropsy, lung neoplasms greater than 5 mm in diameter were promptly frozen in liquid nitrogen, and representative sections were placed in 10% formalin for histopathologic evaluation. The lung neoplasms in this study were selected based on the frozen tissue available and consisted of the following numbers of neoplasms per exposure group: chamber control, 2; 1 mg/m³, 11; 2 mg/m³, 15; and 4 mg/m³, 14.

DNA isolation: Approximately 25 mg of frozen tissue was lysed with proteinase K and then purified using a DNA tissue isolation kit (Qiagen, Valencia, CA). After the DNA was eluted, the samples were stored at 4° C.

DNA amplification: Amplification of *K-ras* exons 1 and 2 in the DNA samples was performed by polymerase chain reaction (PCR) using “nested” outer and inner primers.

For the amplification of *K-ras* exon 1, a proofreader Taq polymerase was used. One microliter DNA was added to a 20 μ L reaction mixture that contained the Platinum[®] Pfx DNA polymerase and the other components that accompanied the kit (GIBCO BRL, Rockville, MD). The following are the primers used to amplify the first exon of *K-ras*:

K12AOS (nested outer sense) 5'-TTATTGTAAGGCCTGCTGAA-3',
K12AOA (outer anti-sense) 5'-GCAGCGTTACCTCTATCGTA-3',
K12AIS (inner sense) 5'-ATGACTGAGTATAAACTTGT-3', and
K12AIA (inner anti-sense) 5'-TCGTA CT CATCCACAAAGTG-3'.

For the outer amplification, samples underwent 30 cycles of denaturation at 94° C for 15 seconds, annealing at 50° C for 30 seconds, and extension at 68° C for 30 seconds. Then 1 μ L of the outer reaction was added to a 50 μ L reaction mixture for a second amplification with inner primers. The conditions were the same as the outer reaction except the annealing step was at 53° C.

For amplification of exon 2 of *K-ras*, 2 μ L DNA was added to a 20 μ L mixture with Promega Taq DNA polymerase (Promega, Madison, WI) to start the outer reaction. Samples were denatured at 94° C for 30 seconds, annealed at 50° C for 30 seconds, and extended at 72° C for 30 seconds for 25 cycles. One microliter from the outer reaction was then added to a 50 μ L reaction mix and amplified under the same conditions as the outer reaction. The following are the primers used to amplify exon 2 of *K-ras*:

K61OS (nested outer sense) 5'-TTCTCAGGACTCCTACAGGA-3',
K61OA (outer anti-sense) 5'-ACCCACCTATAATGGTGAAT-3',
APK6IIS (inner sense) 5'-CAAGTAGTAATTGATGGAGAA-3', and
APK6IIA (inner anti-sense) 5'-AATGGTGAATATCTTCAAATGA-3'.

Following amplification and addition of 5 μ L loading dye, the samples were loaded and electrophoresed on a 1.5% low melting point agarose gel (GIBCO BRL). Samples were then extracted from the agarose and purified using a QIAquick gel extraction kit (Qiagen) and stored at 4° C.

Loss of heterozygosity analysis: The markers analyzed in lung neoplasms for loss of heterozygosity on chromosome 6 in the region of *K-ras* were D6Mit14, D6Mit201, D6Mit372, and D6MCO12 (Zhang *et al.*, 2001). For nonradioactive loss of heterozygosity reactions, thirty cycles of denaturation at 94° C, annealing at 55° C, and extension at 72° C were used for the amplification reaction. Samples were loaded onto a 4% NuSieve[®] gel (3 parts NuSieve[®] agarose to 1 part SeaKem[®] agarose) (FMC BioProducts, Rockland, ME) and electrophoresed at 100 watts to separate the alleles. Analysis was done using ethidium bromide staining under ultraviolet light (312 nm).

For the radioactively labeled reactions, 1 μ L of DNA was added to a 10 μ L mixture that contained [³³P]-dATP (Amersham Pharmacia Biotech, Piscataway, NJ). The same primers and PCR conditions described above were used, but only for 27 cycles. Upon completion of the amplification, sequencing stop solution was added and the samples were denatured. A 5 μ L aliquot was loaded onto a formamide urea gel and electrophoresed at 40 watts for approximately 3 hours to separate the alleles. The gels were dried and exposed to X-ray film overnight.

Because of the chronic inflammation in the lungs and histiocytic infiltrates in close proximity to the alveolar/bronchiolar neoplasms, scoring loss of heterozygosity data was difficult. Most positive scoring samples appeared to have only allelic imbalances rather than complete loss of heterozygosity because of the presence of presumably normal histiocytic infiltrates (normal with respect to molecular alterations in neoplastic cells) within neoplasm tissue samples. Therefore, multiple markers were scored and certain markers were analyzed by both nonradioactive and radioactive labeling methods. For scoring loss of heterozygosity on chromosome 6, only those samples that were positive for at least 3 of the 4 markers were scored as positive.

Sequencing: Cycle sequencing was performed with previously amplified DNA samples using the [³³P]-ThermoSequenase kit from Amersham. The amplification primers were also used as the sequencing primers.

Immunohistochemistry of p53: Immunohistochemical staining for expression of mutant *p53* protein was performed as previously described (Hong *et al.*, 2000) on freshly cut paraffin sections from the original tissue blocks. A 1:300 dilution of the primary polyclonal rabbit antibody (CM-5, Vector Labs, Burlingame, CA), which detects accumulation of the mutant *p53* protein in rodents, was used.

RESULTS

K-ras mutations were identified in 29 of 40 (73%) alveolar/bronchiolar carcinomas from B6C3F₁ mice exposed to vanadium pentoxide (Table O1). The most frequently identified mutations in the vanadium pentoxide-induced lung neoplasms were in codon 12 and consisted of GGT to GAT transitions and GGT to GTT transversions. These two mutations were found at frequencies of 30% (12/40) and 18% (7/40) in the neoplasms from exposed mice, compared to 11% (9/84) and 1% (1/84), respectively, in lung neoplasms from untreated mice in the historical database (Sills *et al.*, 1999b). The other mutations detected in the vanadium pentoxide-induced carcinomas appeared to be random and had a profile similar to that observed for lung neoplasms from untreated B6C3F₁ mice.

The vanadium pentoxide-induced alveolar/bronchiolar carcinomas were also examined for loss of heterozygosity in the region of *K-ras* on chromosome 6 (Table O2). Four closely linked markers were scored visually and phosphorimage analysis was used on one marker to assess "allelic imbalance." Only those samples with at least 3 of 4 markers positive were scored as exhibiting allelic imbalance or loss. By this criterion, 19 of the 40 alveolar/bronchiolar carcinomas exhibited loss of heterozygosity in the region of *K-ras*. A *K-ras* mutation was identified in 17 of those 19 samples, suggesting that samples with one mutated *K-ras* allele had also lost the wild-type allele.

Ten of the alveolar/bronchiolar carcinomas from mice exposed to vanadium pentoxide were stained by immunohistochemistry for overexpression of mutant *p53*. Two of the carcinomas had positive nuclear staining for *p53* in about 10% of the nuclei, and three of the other samples showed scattered nuclear staining with mostly less than 1% positive staining. No staining for *p53* was evident in the other five neoplasm samples. Thus, we did not find evidence of a role for *p53* loss in alveolar/bronchiolar carcinogenesis due to exposure to vanadium pentoxide in B6C3F₁ mice and did not pursue this further.

DISCUSSION

The high frequency (73%) of *K-ras* mutations identified in vanadium pentoxide-induced alveolar/bronchiolar carcinomas compared to that in spontaneous alveolar/bronchiolar carcinomas from untreated B6C3F₁ mice (30%) highlights the importance of *K-ras* activation in the vanadium pentoxide-induced carcinogenic process. There did not seem to be a signature *K-ras* mutation pattern for these chemical-induced lung neoplasms. The mostly random pattern of *K-ras* mutations suggests that vanadium pentoxide either promotes lesions initiated spontaneously or causes oxidative damage that results in a random pattern of *K-ras* mutations. Published evidence supports the latter mechanism (Wang and Bonner, 2000); vanadium pentoxide causes the generation of reactive oxygen species and oxidant-dependent *ras*/MAP kinase pathway activation, and it is known that mutations such as G to T transversions can be due to generation of hydroxyl radicals.

In previous studies, loss of heterozygosity near *K-ras* on chromosome 6 occurred in lung tumors from B6C3F₁ mice following treatment with several chemicals has been shown (Hegi, *et al.*, 1994; Sills *et al.*, 1999a; Zhang *et al.*, 2001). New evidence suggests that the wild-type *K-ras* may act as a mouse lung tumor suppressor gene (Zhang *et al.*, 2001) by inhibiting MAP kinase activity. The loss of heterozygosity in the region of *K-ras*

suggests loss of the wild-type *K-ras* in many vanadium pentoxide-induced lung neoplasms. The findings of both *K-ras* mutations and allelic losses on chromosome 6 in the vanadium pentoxide-induced alveolar/bronchiolar carcinomas, but not in the spontaneous lung tumors examined, suggests that these genetic alterations may be of some importance in understanding the pathogenesis of vanadium pentoxide-induced proliferative lung lesions in B6C3F₁ mice. Furthermore, the detection of biallelic alterations (point mutation and loss of heterozygosity) on chromosome 6 raises the question of which allelic change occurs first. A logical study would be to determine whether *K-ras* mutation or loss of heterozygosity were early events in the development of vanadium pentoxide-induced lung neoplasms. Further molecular analyses of preneoplastic lesions (hyperplasia) or benign neoplasms (adenomas) may help establish the sequence of these genetic events.

It is not surprising that no indication of *p53* loss in vanadium pentoxide-induced lung neoplasms was found. Previous studies on spontaneous and chemical-induced mouse lung neoplasms have not detected much involvement of *p53* (Hegi, *et al.*, 1993; Sills *et al.*, 1995).

The data on *K-ras* mutations and loss of the wild-type *K-ras* allele provide evidence that these genetic alterations play an important role in vanadium pentoxide-induced mouse lung carcinogenesis. Additional published data showing MAP kinase pathway induction and oxidative stress following treatment with vanadium pentoxide (Wang and Bonner, 2000) and that *K-ras* is involved in regulation of redox signaling (Santillo *et al.*, 2001) provide additional evidence that *K-ras* activation may play a major role in the formation of these neoplasms. Plans to investigate the role of MAP kinase signalling in these neoplasms.

REFERENCES

- Bonner, J.C., Rice, A.B., Moomaw, C.R., and Morgan, D.L. (2000). Airway fibrosis in rats induced by vanadium pentoxide. *Am. J. Physiol. Lung Cell. Mol. Physiol.* **278**, L209-L216.
- Hegi, M.E., Soderkvist, P., Foley, J.F., Schoonhoven, R., Swenberg, J.A., Kari, F., Maronpot, R., Anderson, M.W., and Wiseman, R.W. (1993). Characterization of *p53* mutations in methylene chloride-induced lung tumors from B6C3F₁ mice. *Carcinogenesis* **14**, 803-810.
- Hegi, M.E., Devereux, T.R., Dietrich, W.F., Cochran, C.J., Lander, E.S., Foley, J.F., Maronpot, R.R., Anderson, M.W., and Wiseman, R.W. (1994). Allelotype analysis of mouse lung carcinomas reveals frequent allelic losses on chromosome 4 and an association between allelic imbalances on chromosome 6 and *K-ras* activation. *Cancer Res.* **54**, 6257-6264.
- Hong, H.H., Devereux, T.R., Melnick, R.L., Moomaw, C.R., Boorman, G.A., and Sills, R.C. (2000). Mutations of *ras* protooncogenes and *p53* tumor suppressor gene in cardiac hemangiosarcomas from B6C3F₁ mice exposed to 1,3-butadiene for 2 years. *Toxicol. Pathol.* **28**, 529-534.
- Patel, A.C., Anna, C.H., Foley, J.F., Stockton, P.S., Tyson, F.L., Barrett, J.C., and Devereux, T.R. (2000). Hypermethylation of the *p16* (*Ink4a*) promoter in B6C3F₁ mouse primary lung adenocarcinomas and mouse lung cell lines. *Carcinogenesis* **21**, 1691-1700.
- Santillo, M., Mondola, P., Serù, R., Annella, T., Cassano, S., Ciullo, I., Tecce, M.F., Iacomino, G., Damiano, S., Cuda, G., Paternò, R., Martignetti, V., Mele, E., Feliciello, A., and Avvedimento, E.V. (2001). Opposing functions of *Ki-* and *Ha-Ras* genes in the regulation of redox signals. *Curr. Biol.* **11**, 614-619.
- Shapiro, G.I., Park, J.E., Edwards, C.D., Mao, L., Merlo, A., Sidransky, D., Ewen, M.E., and Rollins, B.J. (1995). Multiple mechanisms of *p16INK4A* inactivation in non-small cell lung cancer cell lines. *Cancer Res.* **55**, 6200-6209.

Sills, R.C., Hong, H.L., Greenwell, A., Herbert, R.A., Boorman, G.A., and Devereux, T.R. (1995). Increased frequency of *K-ras* mutations in lung neoplasms from female B6C3F1 mice exposed to ozone for 24 or 30 months. *Carcinogenesis* **16**, 1623-1628.

Sills, R.C., Hong, H.L., Melnick, R.L., Boorman, G.A., and Devereux, T.R. (1999a). High frequency of codon 61 *K-ras* A to T transversions in lung and Harderian gland neoplasms of B6C3F1 mice exposed to chloroprene (2-chloro-1,3-butadiene) for 2 years, and comparisons with the structurally related chemicals isoprene and 1,3-butadiene. *Carcinogenesis* **20**, 657-662.

Sills, R.C., Boorman, G.A., Neal, J.E., Hong, H.L., and Devereux, T.R. (1999b). Mutations in *ras* genes in experimental tumours of rodents. In *The use of short- and medium-term tests for carcinogens and data on genetic effects in carcinogenic hazard evaluation* (D.B. McGregor, J.M. Rice, and S. Venitt, Eds.), pp. 55-86. International Agency for Research on Cancer, Lyon France.

Wang, Y.Z., and Bonner, J.C. (2000). Mechanism of extracellular signal-regulated kinase (ERK)-1 and ERK-2 activation by vanadium pentoxide in rat pulmonary myofibroblasts. *Am. J. Respir. Cell Mol. Biol.* **22**, 590-596.

Zhang, Z., Wang, Y., Vikis, H.G., Johnson, L., Liu, G., Li, J., Anderson, M.W., Sills, R.C., Hong, H.L., Devereux, T.R., Jacks, T., Guan, K.L., and You, M. (2001). Wild Type *Kras* 2 can inhibit lung carcinogenesis in mice. *Nat. Genet.* **29**, 25-33.

TABLE O1
Mutations of K-ras in Alveolar/bronchiolar Carcinomas from B6C3F₁ Mice
in the 2-Year Inhalation Study of Vanadium Pentoxide

Treatment	Activated K-ras (%)	Codon 12-13 (Normal=GGTGGC)					Codon 61 (Normal=CAA)			
		GTT	GAT	TGT	CGT	CGC	CTA	CAT	CGA	CAC
Historical Control ^a	25/84 (30%)	1 (1%)	9 (11%)	5	0	3	0	4	2	1
V ₂ O ₅ Exposed	29/40 (73%)	7 (18%)	12 (30%)	1	0	1	0	4	2	2

^a Spontaneous alveolar/bronchiolar carcinomas from control B6C3F₁ mice; Sills *et al.*, 1999b

TABLE O2
Mutations/Loss of Heterozygosity on Chromosome 6 in the Region of K-ras
in Alveolar/bronchiolar Carcinomas from B6C3F₁ Mice in the 2-Year Inhalation Study
of Vanadium Pentoxide

	Chamber Control	1 mg/m ³	2 mg/m ³	4 mg/m ³
Activated K-ras (%)	0/2	7/11 (64%)	12/15 (80%)	11/14 (71%)
Alveolar/bronchiolar carcinoma with loss of heterozygosity	0	6	3	10
K-ras mutation/loss of heterozygosity	0	5/6 (83%)	3/3 (100%)	9/10 (90%)

Chemical	TR No.	Chemical	TR No.
Ethylene Glycol	413	Nitrofurantoin	341
Ethylene Glycol Monobutyl Ether	484	Nitrofurazone	337
Ethylene Oxide	326	Nitromethane	461
Ethylene Thiourea	388	<i>p</i> -Nitrophenol	417
Eugenol	223	<i>o</i> -Nitrotoluene	504
FD&C Yellow No. 6	208	<i>p</i> -Nitrotoluene	498
Fumonisin B ₁	496	Ochratoxin A	358
Furan	402	Oleic Acid Diethanolamine Condensate	481
Furfural	382	Oxazepam (Mice)	443
Furfuryl Alcohol	482	Oxazepam (Rats)	468
Furosemide	356	Oxymetholone	485
Gallium Arsenide	492	Oxytetracycline Hydrochloride	315
Geranyl Acetate	252	Ozone and Ozone/NNK	440
Glutaraldehyde	490	Penicillin VK	336
Glycidol	374	Pentachloroanisole	414
Guar Gum	229	Pentachloroethane	232
Gum Arabic	227	Pentachloronitrobenzene	325
HC Blue 1	271	Pentachlorophenol, Purified	483
HC Blue 2	293	Pentachlorophenol, Technical Grade	349
HC Red 3	281	Pentaerythritol Tetranitrate	365
HC Yellow 4	419	Phenolphthalein	465
Hexachlorocyclopentadiene	437	Phenylbutazone	367
Hexachloroethane	361	Phenylephrine Hydrochloride	322
4-Hexylresorcinol	330	N-Phenyl-2-Naphthylamine	333
Hydrochlorothiazide	357	<i>o</i> -Phenylphenol	301
Hydroquinone	366	Polybrominated Biphenyl Mixture (Firemaster FF-1) (Gavage)	244
8-Hydroxyquinoline	276	Polybrominated Biphenyl Mixture (Firemaster FF-1) (Feed)	398
Indium Phosphide	499	Polysorbate 80 (Glycol)	415
Iodinated Glycerol	340	Polyvinyl Alcohol	474
Isobutene	487	Primidone	476
Isobutyl Nitrite	448	Probenecid	395
Isobutyraldehyde	472	Promethazine Hydrochloride	425
Isophorone	291	Propylene	272
Isoprene	486	1,2-Propylene Oxide	267
Lauric Acid Diethanolamine Condensate	480	Propyl Gallate	240
<i>d</i> -Limonene	347	Pyridine	470
Locust Bean Gum	221	Quercetin	409
60-Hz Magnetic Fields	488	Resorcinol	403
Magnetic Field Promotion	489	Rhodamine 6G	364
Malonaldehyde, Sodium Salt	331	Rotenone	320
Manganese Sulfate Monohydrate	428	Roxarsone	345
D-Mannitol	236	Salicylazosulfapyridine	457
Marine Diesel Fuel and JP-5 Navy Fuel	310	Scopolamine Hydrobromide Trihydrate	445
Melamine	245	Sodium Azide	389
2-Mercaptobenzothiazole	332	Sodium Fluoride	393
Mercuric Chloride	408	Sodium Nitrite	495
Methacrylonitrile	497	Sodium Xylenesulfonate	464
8-Methoxy psoralen	359	Stannous Chloride	231
α -Methylbenzyl Alcohol	369	Succinic Anhydride	373
Methyl Bromide	385	Talc	421
Methyl Carbamate	328	Tara Gum	224
Methyl dopa Sesquihydrate	348	2,3,7,8-Tetrachlorodibenzo- <i>p</i> -Dioxin (Dermal)	201
Methylene Chloride	306	2,3,7,8-Tetrachlorodibenzo- <i>p</i> -Dioxin (Gavage)	209
4,4'-Methylenedianiline Dihydrochloride	248	1,1,1,2-Tetrachloroethane	237
Methyleugenol	491	Tetrachloroethylene	311
Methyl Methacrylate	314	Tetracycline Hydrochloride	344
N-Methylolacrylamide	352	Tetrafluoroethylene	450
Methylphenidate Hydrochloride	439	1-Trans-Delta ⁹ -Tetrahydrocannabinol	446
Mirex	313	Tetrahydrofuran	475
Molybdenum Trioxide	462	Tetrakis(Hydroxymethyl)Phosphonium Sulfate	296
Monochloroacetic Acid	396	Tetrakis(Hydroxymethyl)Phosphonium Chloride	296
Monuron	266	Tetranitromethane	386
Nalidixic Acid	368	Theophylline	473
Naphthalene (Mice)	410	4,4-Thiobis(6- <i>t</i> -Butyl- <i>m</i> -Cresol)	435
Naphthalene (Rats)	500	Titanocene Dichloride	399
Nickel (II) Oxide	451	Toluene	371
Nickel Sulfate Hexahydrate	454	2,4- & 2,6-Toluene Diisocyanate	251
Nickel Subsulfide	453	<i>o</i> -Toluidine Hydrochloride	153
<i>p</i> -Nitroaniline	418	Triamterene	420
<i>o</i> -Nitroanisole	416	Tribromomethane	350
<i>p</i> -Nitrobenzoic Acid	442	Trichloroethylene	243

Chemical	TR No.	Chemical	TR No.
Trichloroethylene	273	4-Vinylcyclohexene	303
1,2,3-Trichloropropane	384	4-Vinyl-1-Cyclohexene Diepoxide	362
Tricresyl Phosphate	433	Vinylidene Chloride	228
Triethanolamine	449	Vinyl Toluene	375
Tris(2-Chloroethyl) Phosphate	391	Xylenes (Mixed)	327
Tris(2-Ethylhexyl) Phosphate	274	2,6-Xylidine	278
Turmeric Oleoresin (Curcumin)	427	Zearalenone	235
Vanadium Pentoxide	507	Ziram	238



National Toxicology Program

National Institute of Environmental Health Sciences

National Institutes of Health

P.O. Box 12233, MD K2-05

Durham, NC 27709

Tel: 984-287-3211

ntpwebrequest@niehs.nih.gov

<https://ntp.niehs.nih.gov>

ISSN 2378-8925